

TABLE OF CONTENTS

SHEET NO.	SHEET DESCRIPTION
1	NOTES AND BOM
2-4	WDC PACKAGING

NOTES: VALID UNLESS OTHERWISE SPECIFIED

1. GENERAL:

- a. APPLICATION SPECIFICATION SEE: AS-34992-001
-CONTAINS: PRODUCT INTRODUCTION, PRODUCT SUMMARY, CONNECTOR ASSEMBLY, PACKAGING INFORMATION, CONNECTOR MATING, SERVICE INSTRUCTIONS, ELECTRICAL CONTINUITY CHECKING, CRIMPING, AND TROUBLESHOOTING.
- b. PRODUCT SPECIFICATION SEE: PS-34992-001
CONTAINS: PRODUCT INTRODUCTION, PRODUCT SUMMARY, RATINGS (CURRENT, TEMPERATURE, AND FLAMMABILITY), AND PRODUCT VALIDATION.
- c. PACKAGING SPECIFICATION PER MOLEX DRAWING: TBD
- d. PARTS MUST BE IN COMPLIANCE TO MOLEX CHEMICAL SUBSTANCES FOR PRODUCTS AND PACKAGING SPECIFICATION: QEHS-699000-300
- e. DATA MUST BE SUBMITTED UNDER THE MOLEX PART NUMBER TO IMDS (COMPANY ID#13255)
- f. FLAMMABILITY REQUIREMENT: PER ISO3795 OR GM3191
 - 1. BURN RATE 100mm/MIN MAXIMUM
 - 2. MATERIAL MUST BE SELF EXTINGUISHING

2. DESIGN - MATERIALS:

- a. SEE BOM TABLE FOR MATERIAL
- b. REGRIND 25% MAX BY WEIGHT

3. DESIGN - GEOMETRY:

- a. ALL GRAPHIC DATA IS BASIC (NO TOLERANCE) AND MUST BE TAKEN FROM THE DATA FILE AT ITS LATEST REVISION.
- b. GEOMETRIC DIMENSIONS AND TOLERANCES PER ASME Y14.5M-2009
- c. EDGES AND UNDIMENSIONED DETAILS PER ISO13715
- d. CORNERS SHOWN AS SHARP TO BE R 0.2 MAX.
- e. LETTERING SHALL BE 0.15 MAX RAISED IN 0.25 MAX RECESS PAD. THIS INCLUDES RECYCLING CODE, CAVITY ID, VENDOR IDENTIFICATION, AND CUSTOMER MATERIAL NUMBER.
- f. LASER MARKING: N/A

4. DESIGN - MANUFACTURING:

- a. ALLOWABLE FLASH MAX 0.20 HIGH BY MAX 0.13 THICK.
- b. ALLOWABLE SPLIT/PARTING LINE MISMATCH 0.2 MAX.
- c. EJECTOR PIN MARKS TO BE FLUSH TO 0.25 MAX DEPRESSED. LOCATION MUST BE APPROVED BY PRODUCT ENGINEERING. EJECTOR PIN MARKS NOT PERMISSIBLE ON OR NEAR DATUM TARGET AREA.
- d. ALLOWABLE GATE VESTIGE FLUSH TO 0.25 MAX RECESS. LOCATION MUST BE APPROVED BY PRODUCT ENGINEERING.
- e. VISUAL DEFECTS SHALL MEET COSMETIC STANDARD PS-45499-002 (Class B).
- f. NO EXTERNAL MOLD RELEASE AGENT ALLOWED DURING MANUFACTURING.

5. DESIGN SPECIFIC APPLICATION NOTES:

- a. SEE AS-34992-001

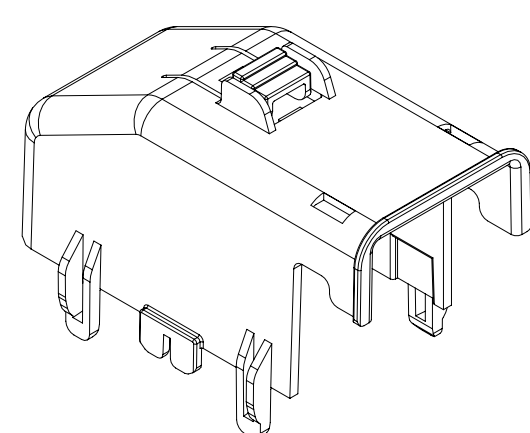

TOP LATCH

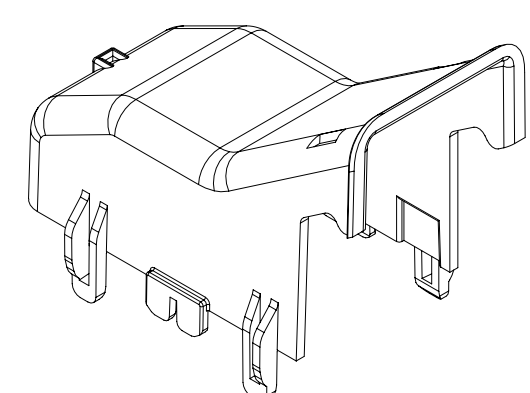

END LATCH

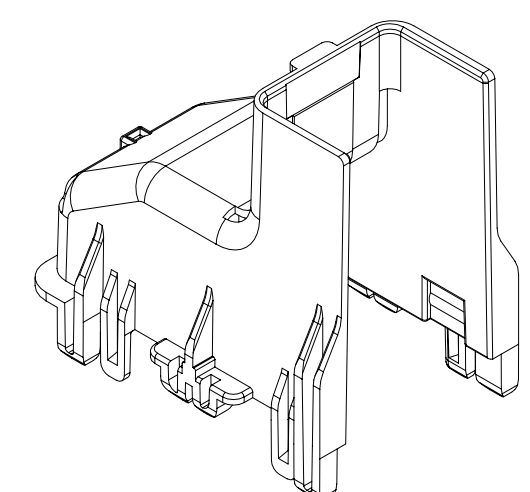

STRAIGHT WIRE DRESS

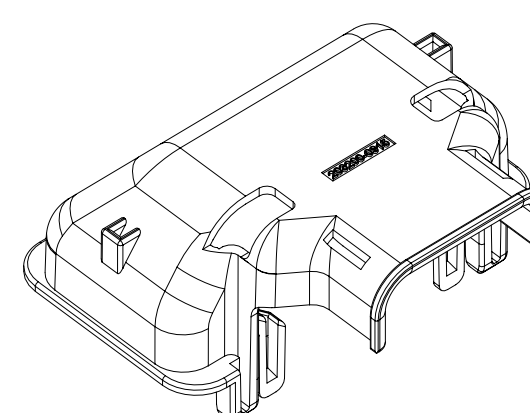

90 DEGREE

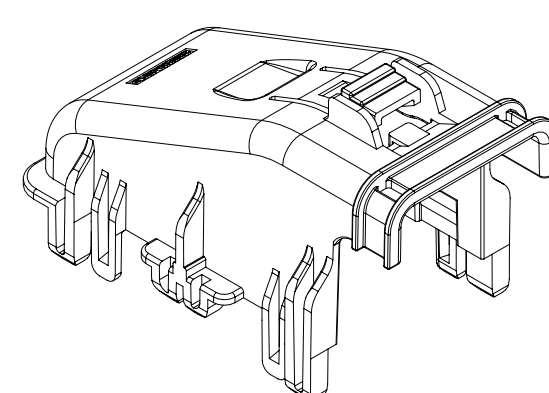

TOP LATCH LOW PROFILE

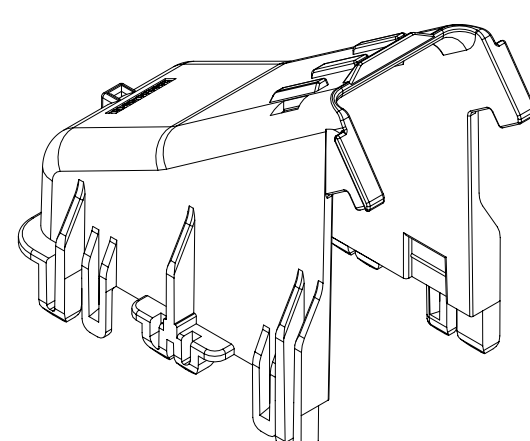

END LATCH LARGE VOLUME

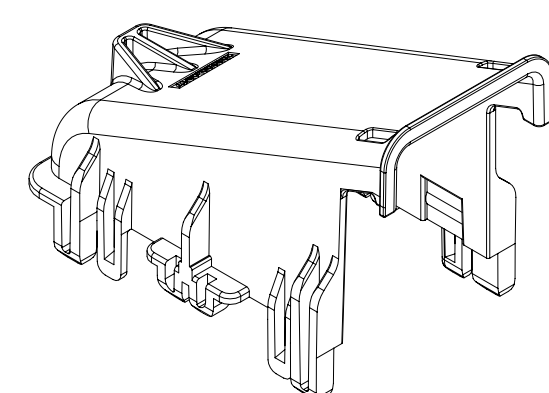

END LATCH LOW PROFILE

BILL OF MATERIALS (BOM)

DESCRIPTION	PART NUMBER	CHARTED DIMENSIONS			COLOR	MATERIAL	NOTES	STATUS
		(A) (MM)	(B) (MM)	(C) (MM)				
CONDUIT (19mm)	34992-0906	SEE SD-34992-906						SALEABLE
	34992-0908						RESTRICTED	SALEABLE
CONDUIT (25mm)	34992-0907	SEE SD-34992-906						SALEABLE
	34992-0909						RESTRICTED	SALEABLE
	2032000919						DRAIN HOLES	SALEABLE
TOP LATCH	203200-0901	36.74	66.44	44.58	BLACK	PA66 GF35		SALEABLE
END LATCH	203200-0902	36.74	64.15	51.64	BLACK	PA66 GF35	GECU COMPATIBLE	SALEABLE
	203200-0903	36.74	64.15	51.64	BLACK	PA66 GF35	RESTRICTED	SALEABLE
STRAIGHT WIRE DRESS	203200-0904	37.19	56.18	54.28	BLACK	PA66 GF35		SALEABLE
90 DEG LARGE VOLUME	203200-0905	63.25	56.48	33.27	BLACK	PA66 GF35		OBSOLETE
90 DEGREE	203200-0915	63.25	56.48	33.27	BLACK	PA66 GF35	BUNDLE RESTR. $\triangle 5$	SALEABLE
END LATCH LARGE VOLUME	203200-0910	37.19	65.87	57.00	BLACK	PA66 GF35	GECU COMPATIBLE	SALEABLE
TOP LATCH LOW PROFILE	203200-0912	37.19	68.46	40.33	BLACK	PA66 GF35	GECU LEVER ONLY	OBSOLETE
	203200-0916	37.19	68.46	40.33	BLACK	PA66 GF35	BUNDLE RESTR. $\triangle 5$	SALEABLE
END LATCH LOW PROFILE	203200-0913	37.19	66.44	46.42	BLACK	PA66 GF35	GECU COMPATIBLE	OBSOLETE
	203200-0917	37.19	66.44	46.42	BLACK	PA66 GF35	BUNDLE RESTR. $\triangle 5$	SALEABLE

QUALITY SYMBOLS ∇ = 0 ∇ = 0 ∇ = 0 ∇ = 0 ∇ = 0 ∇ = 0 ∇ = 0 ∇ = 0 ∇ = 0 ∇ = 0	THIS DRAWING CONTAINS INFORMATION THAT IS PROPRIETARY TO MOLEX ELECTRONIC TECHNOLOGIES, LLC AND SHOULD NOT BE USED WITHOUT WRITTEN PERMISSION									
	EC NO: 653738 DRWN: NBOHIDAR CHKD: BDICK01 REV APPR: BDICK01	2021/02/04	GENERAL TOLERANCES (UNLESS SPECIFIED)		DIMENSION UNITS	SCALE				
		2021/06/18	ANGULAR TOL \pm		mm	2:1				
		2021/06/18	4 PLACES \pm	APROFFITT	DATE	2016/10/05				
	PRODUCT CUSTOMER DRAWING	3 PLACES \pm	CHKD BY	DATE	SKRAJENDRANA 2016/11/04					
		2 PLACES \pm	APPR BY	DATE	VKOSHY 2016/11/04					
		1 PLACE \pm	DRAWING SIZE	THIRD ANGLE PROJECTION	D					
		0 PLACES \pm	DRAFT WHERE APPLICABLE MUST REMAIN WITHIN DIMENSIONS							
	SERIES		MATERIAL NUMBER		CUSTOMER		DOCUMENT NUMBER: 2032000001-SD DOC TYPE: PSD DOC PART: 000 SHEET NUMBER: 1 OF 4			

203200-0901 - Top Latch

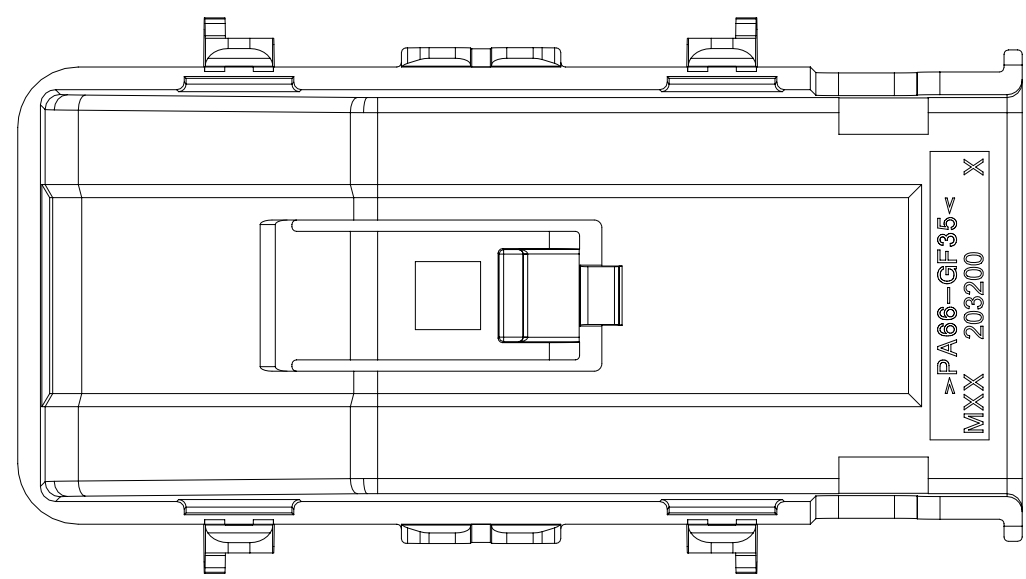
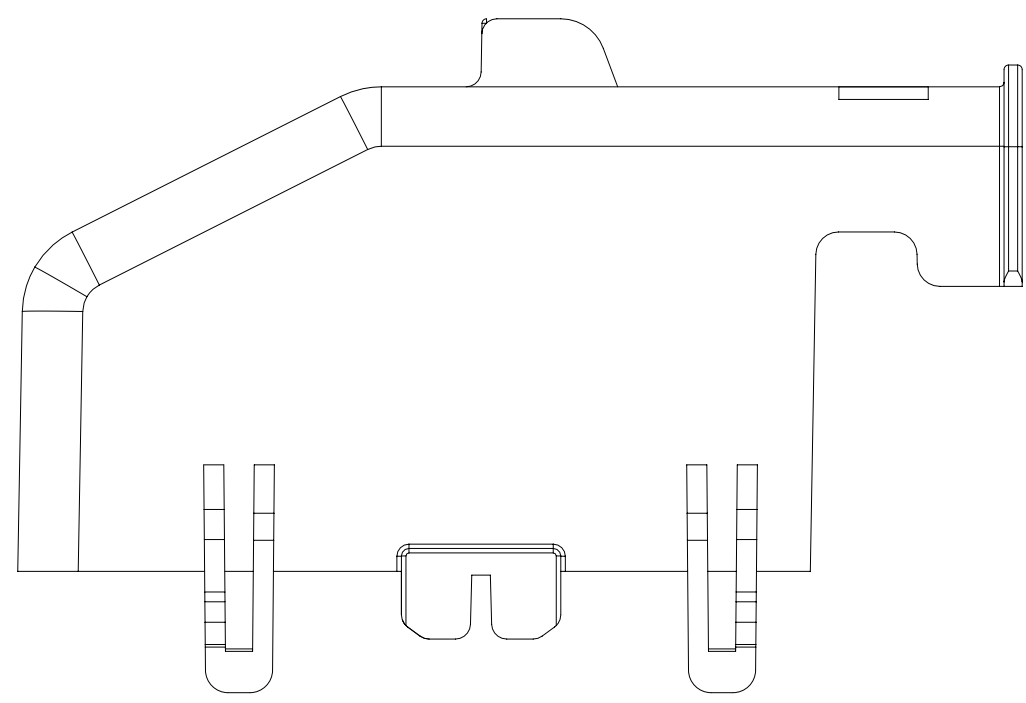
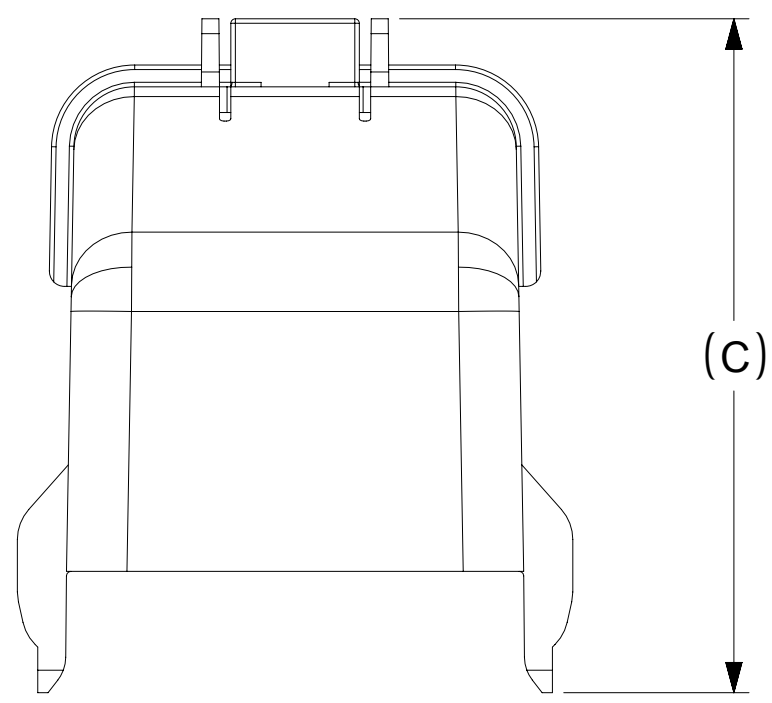
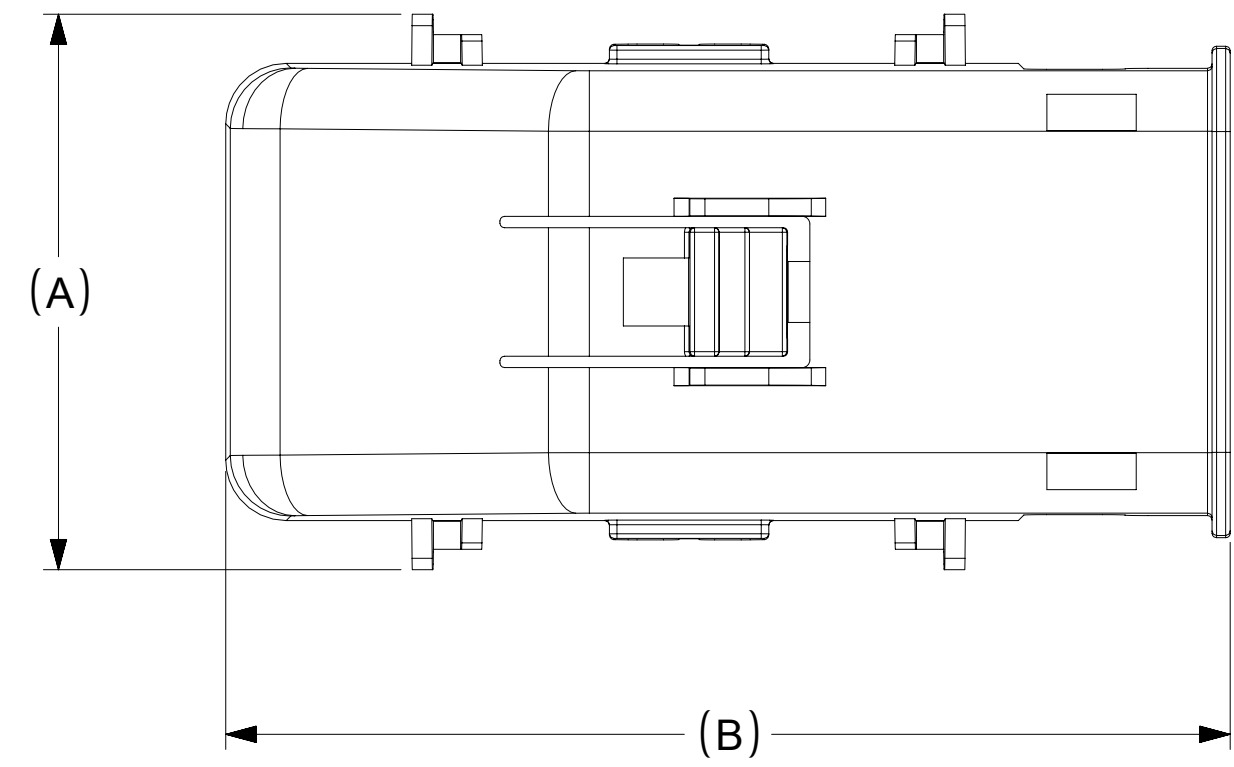

203200-0902 - End Latch

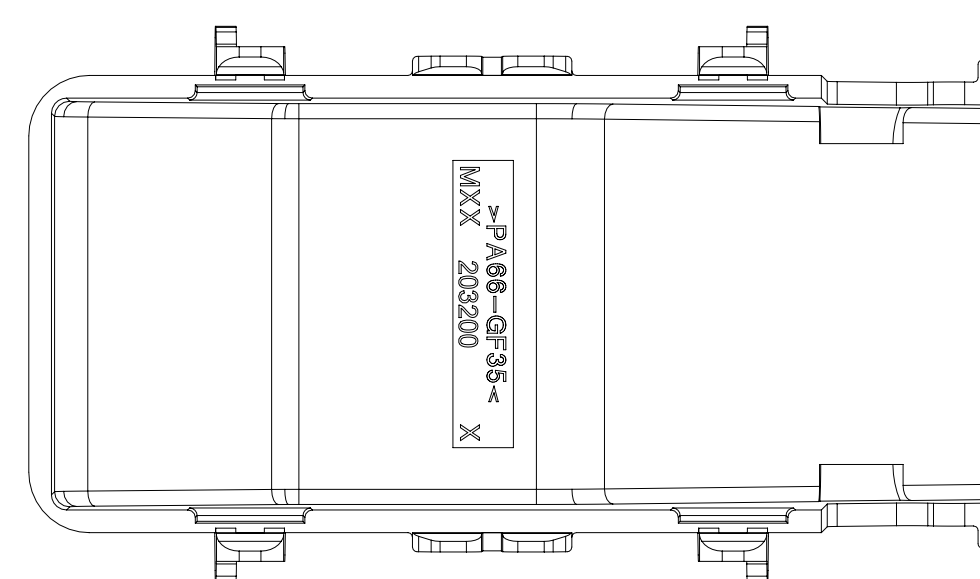
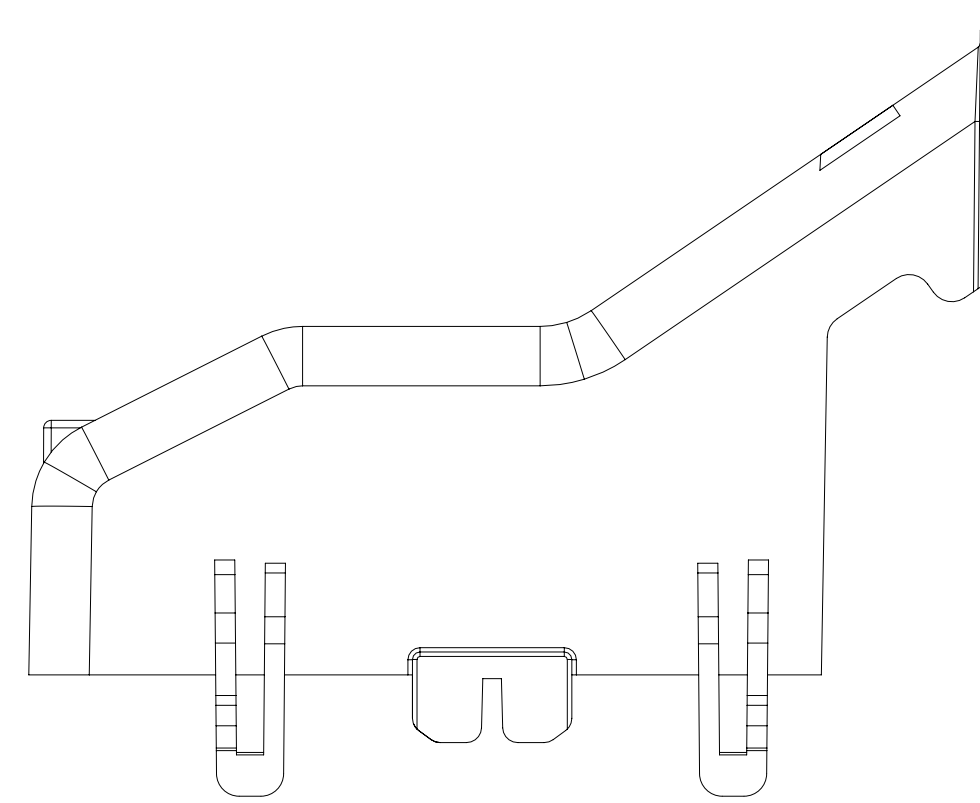
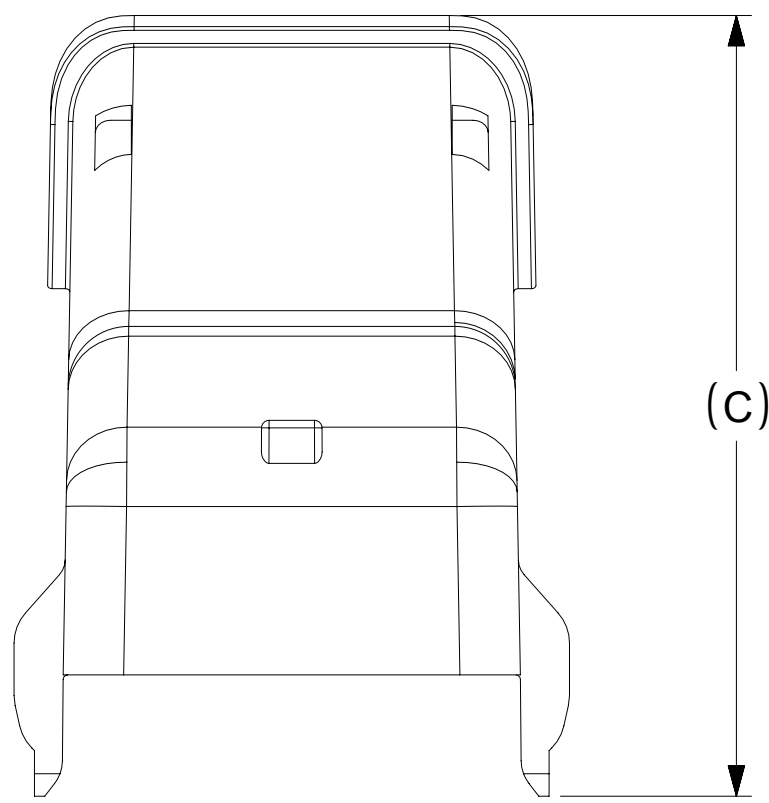
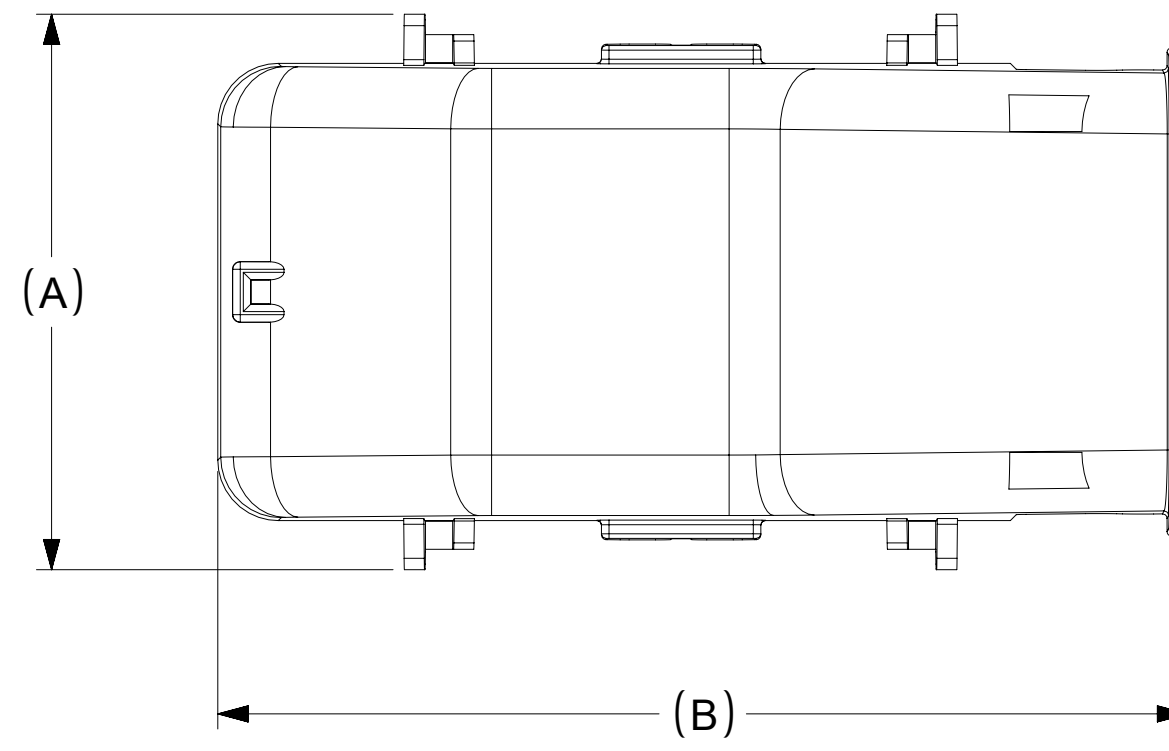

203200-0910

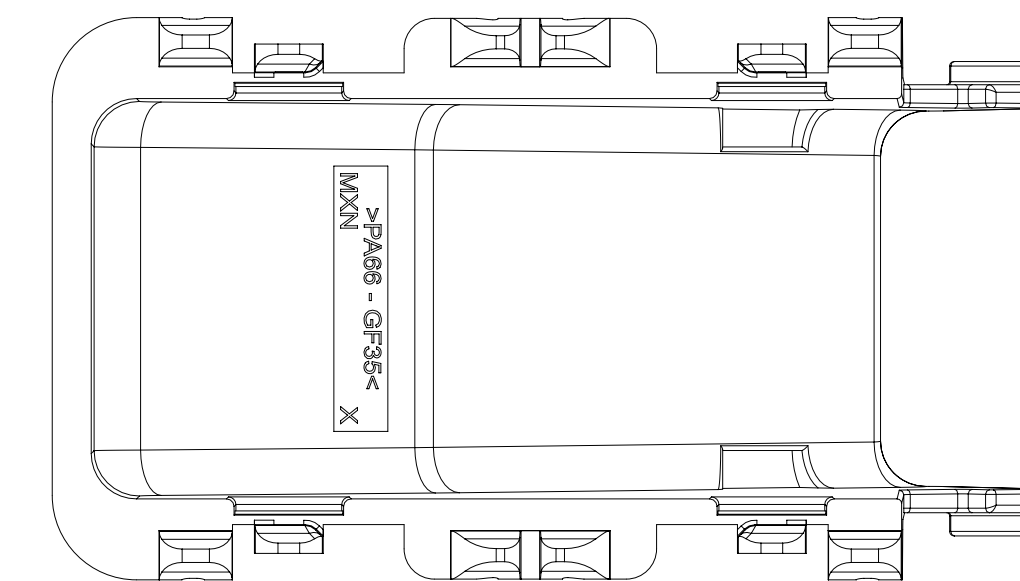
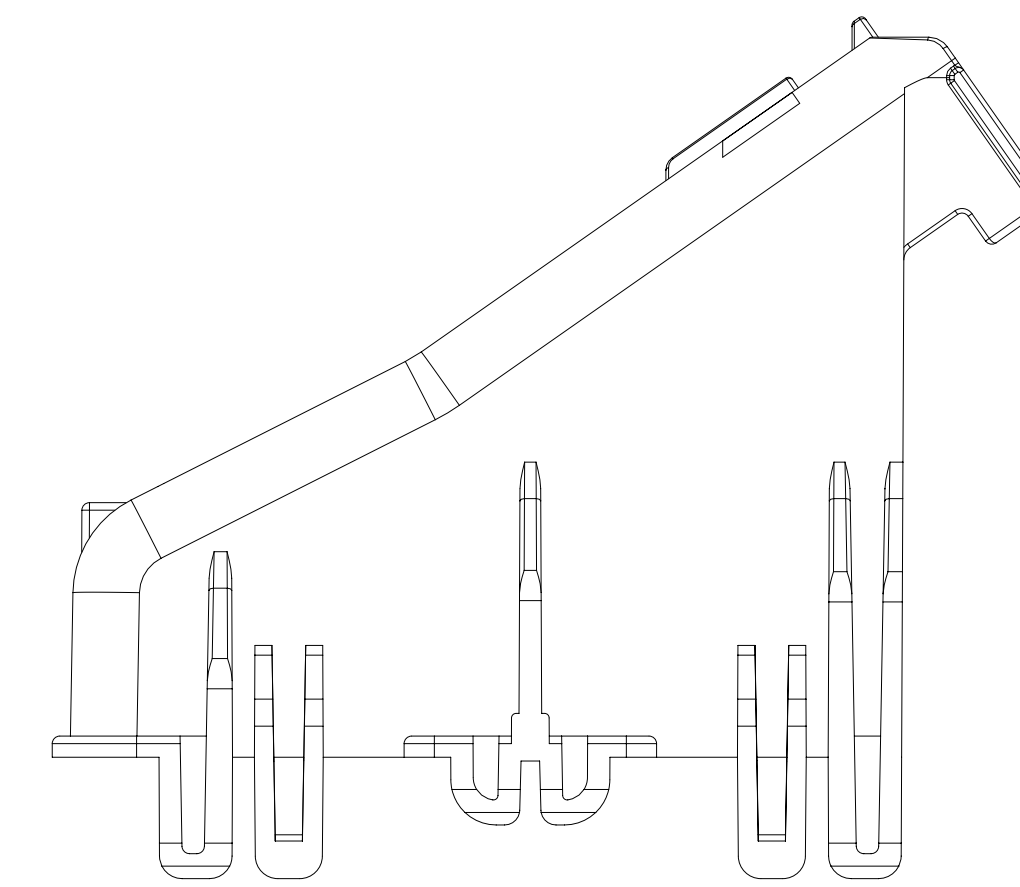
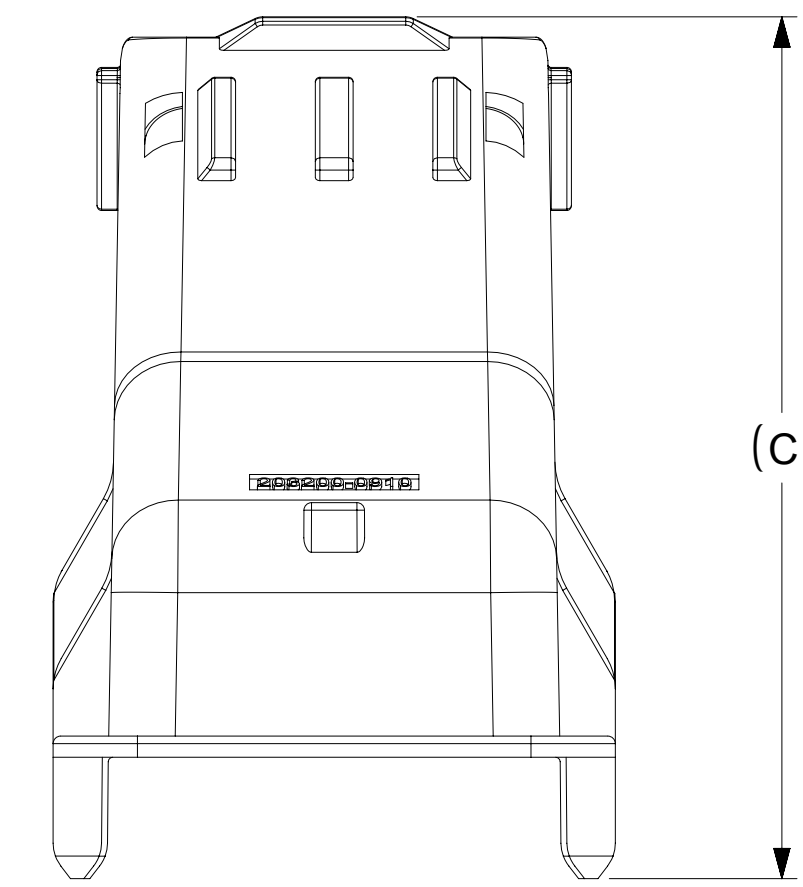
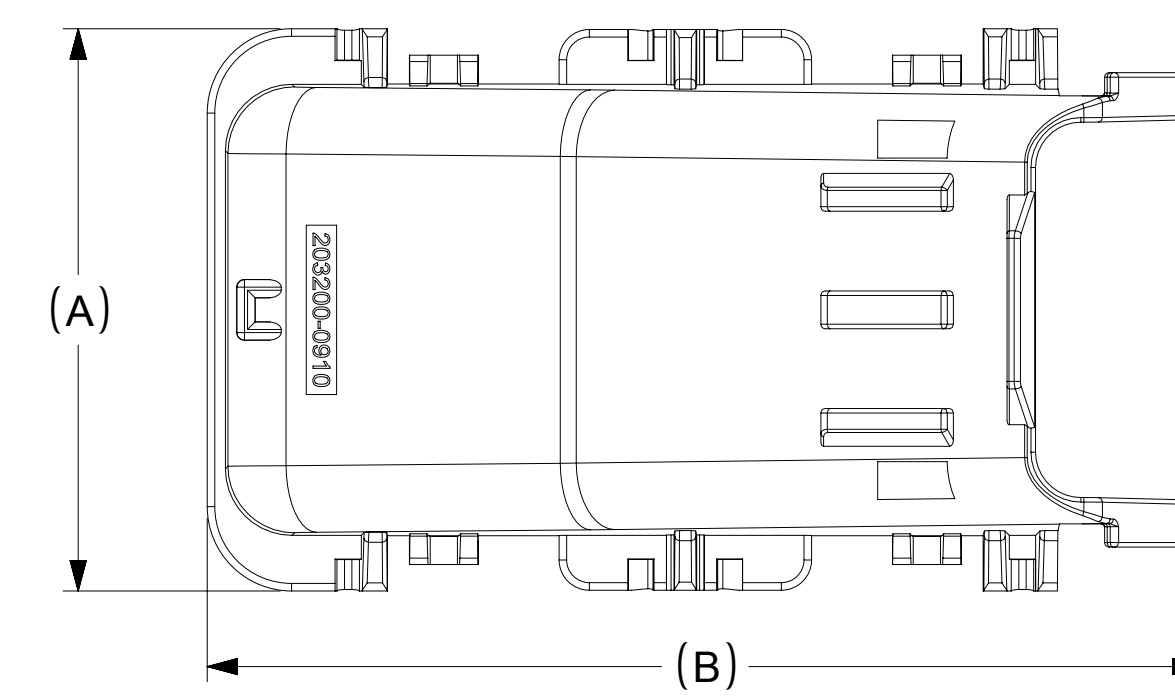

QUALITY SYMBOLS F = 0 E = 0 D = 0 C = 0 B = 0 A = 0 X = 0	THIS DRAWING CONTAINS INFORMATION THAT IS PROPRIETARY TO MOLEX ELECTRONIC TECHNOLOGIES, LLC AND SHOULD NOT BE USED WITHOUT WRITTEN PERMISSION		GENERAL TOLERANCES (UNLESS SPECIFIED) DIMENSION UNITS: mm SCALE: 2:1			
	DRWN BY: NBOHIDAR CHKD BY: BDICK01 APPR BY: BDICK01		DRWN BY: DATE: 2016/10/05 CHKD BY: DATE: 2016/11/04 APPR BY: DATE: 2016/11/04			GPCM GENERAL MARKET WIRE DRESS COVER
	EC NO: 653738 DRWN: NBOHIDAR CHKD: BDICK01 APPR: BDICK01		DRAFT WHERE APPLICABLE MUST REMAIN WITHIN DIMENSIONS			
	C10		DRAWING SIZE: D THIRD ANGLE PROJECTION			SERIES: 203200 MATERIAL NUMBER: CHARTED CUSTOMER:
RELEASE STATUS: P1 RELEASE DATE: 2021/06/18 12:14:17		DOCUMENT NUMBER: 2032000001-SD DOC TYPE: PSD DOC PART: 000 SHEET NUMBER: 2 OF 4				

203200-0903 - End Latch

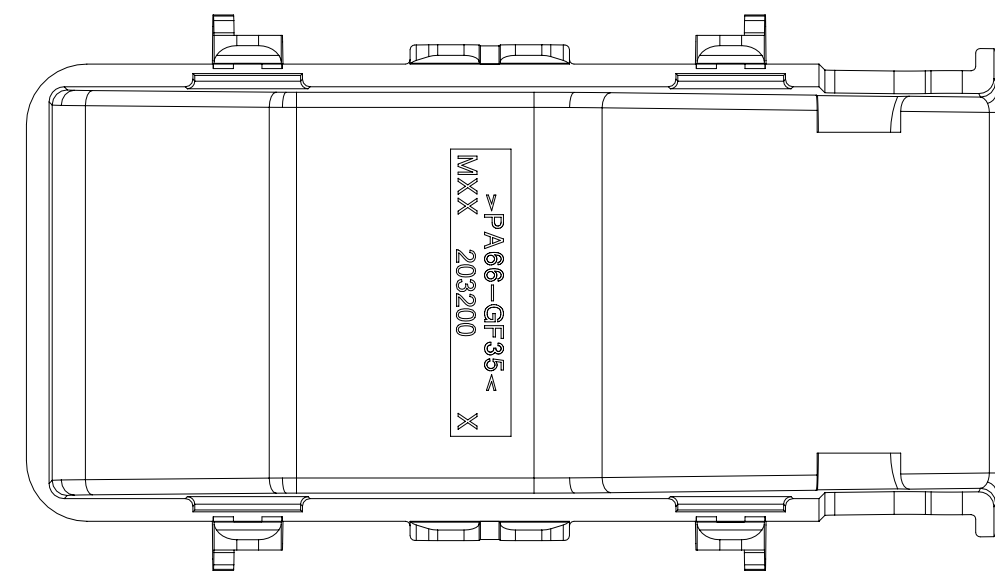
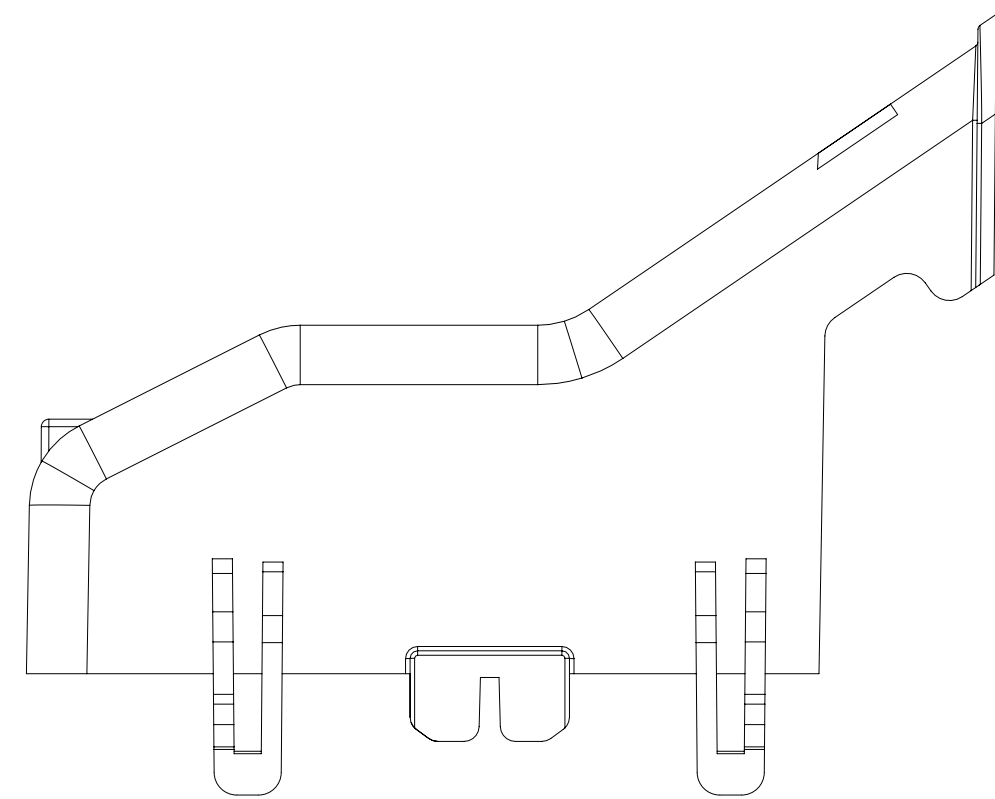
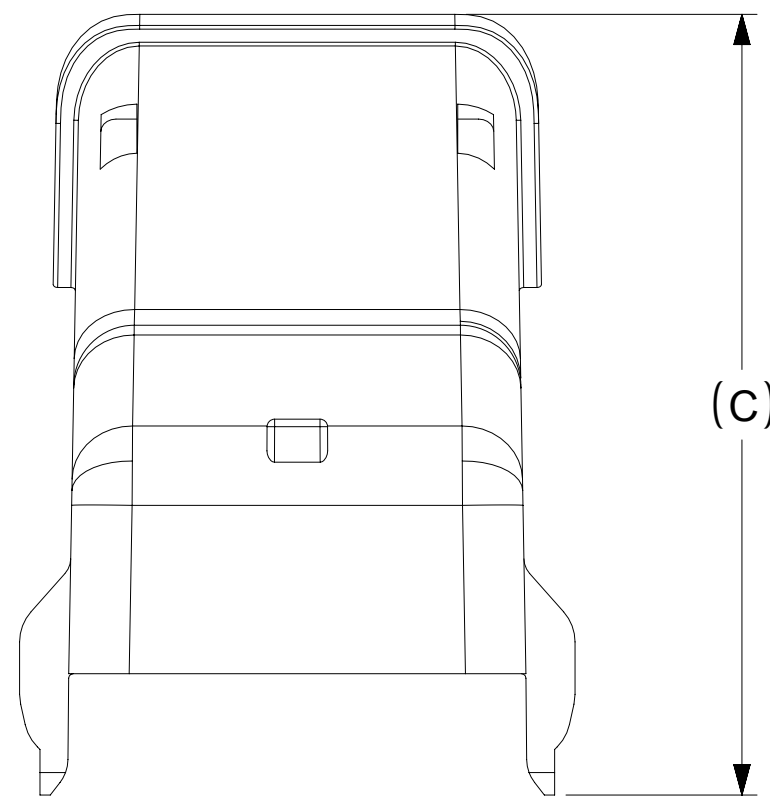
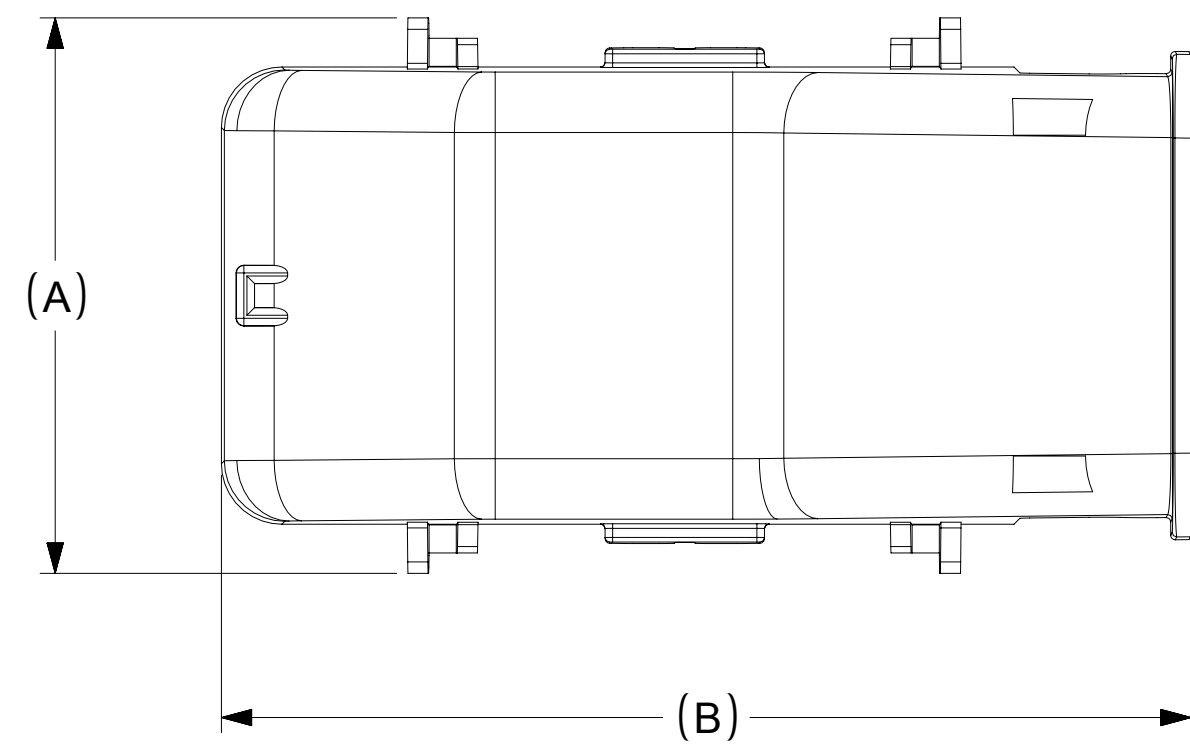

203200-0904 - STRAIGHT WIRE DRESS

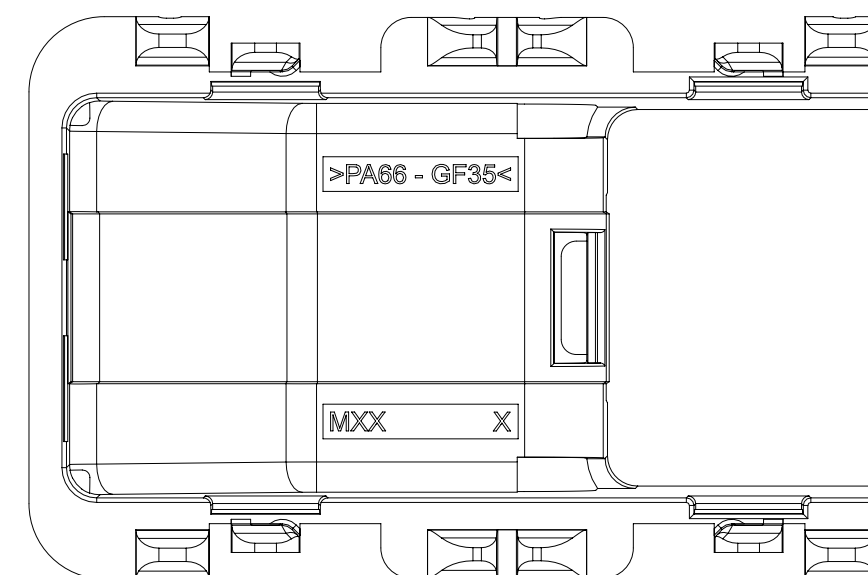
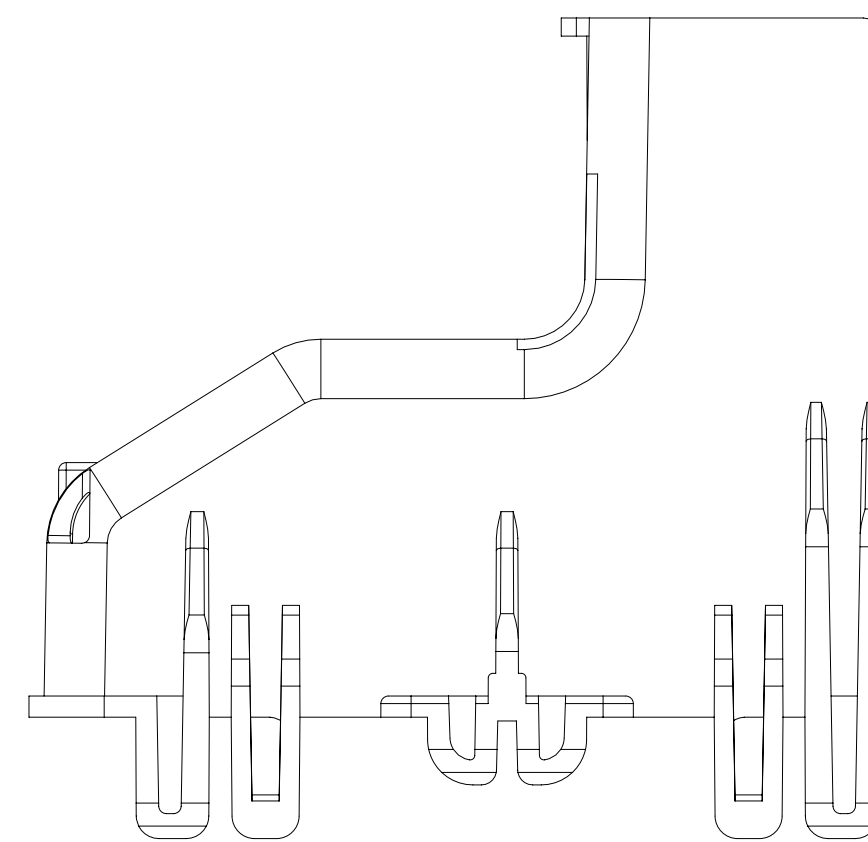
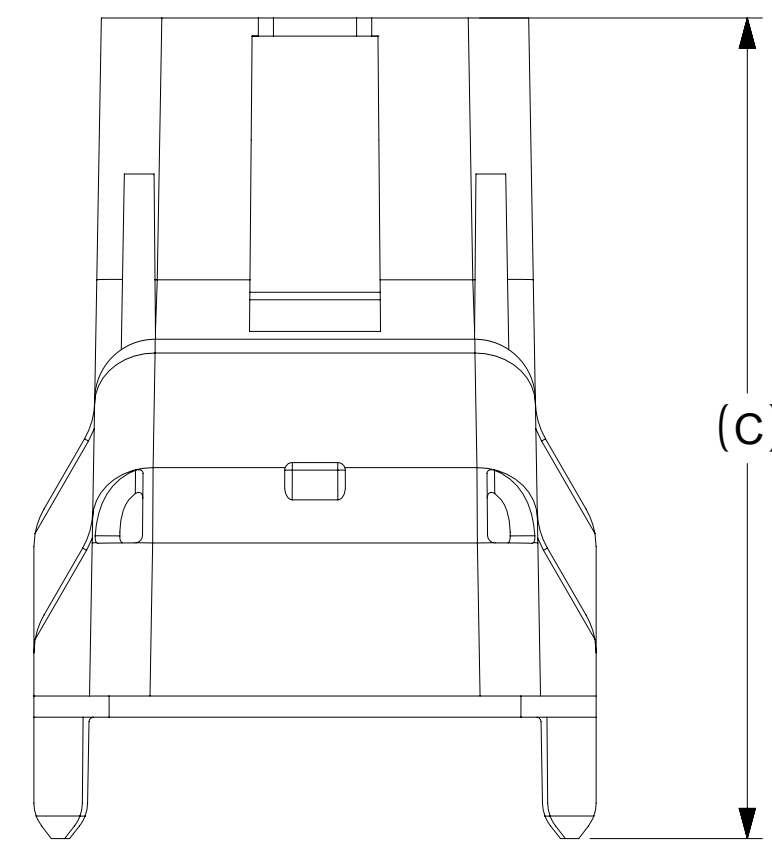
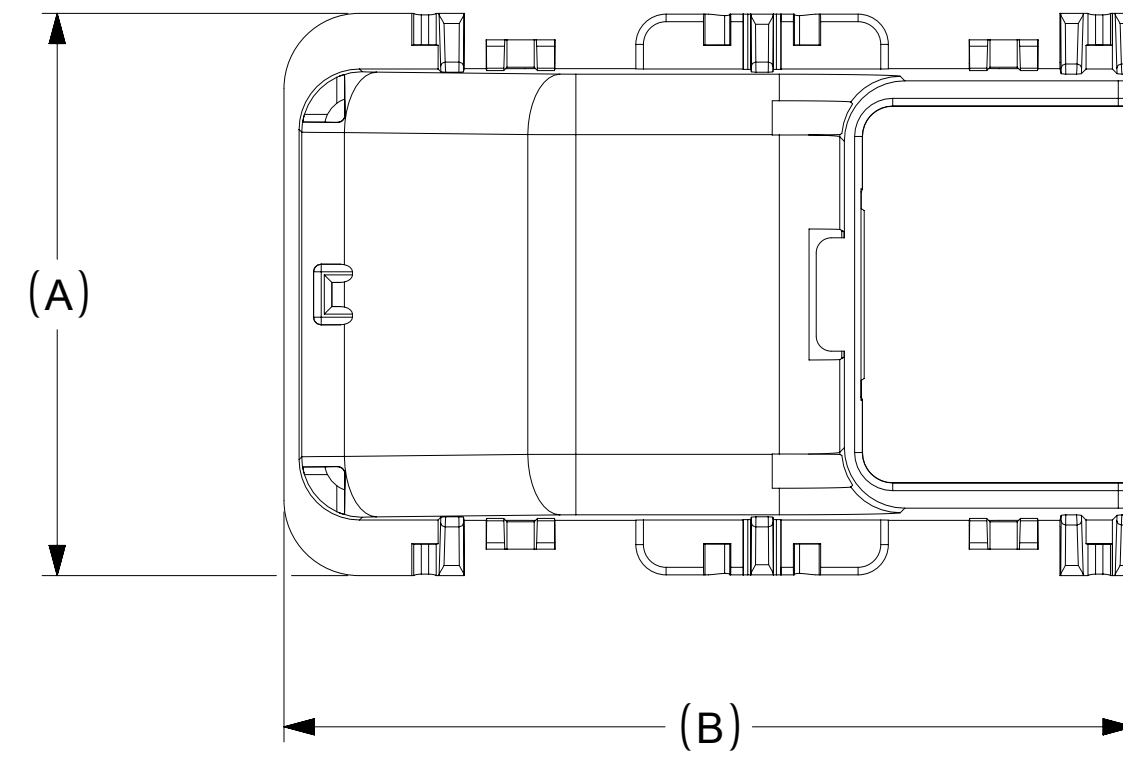

203200-0915 - 90 DEGREE

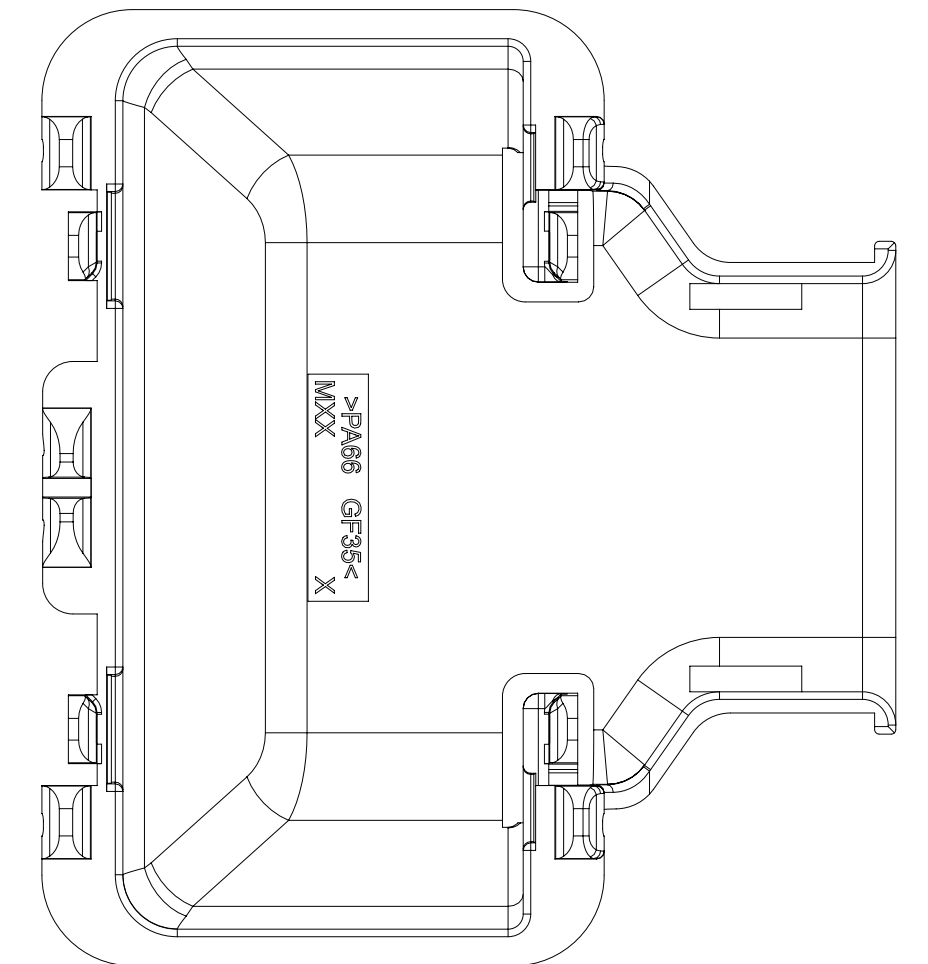
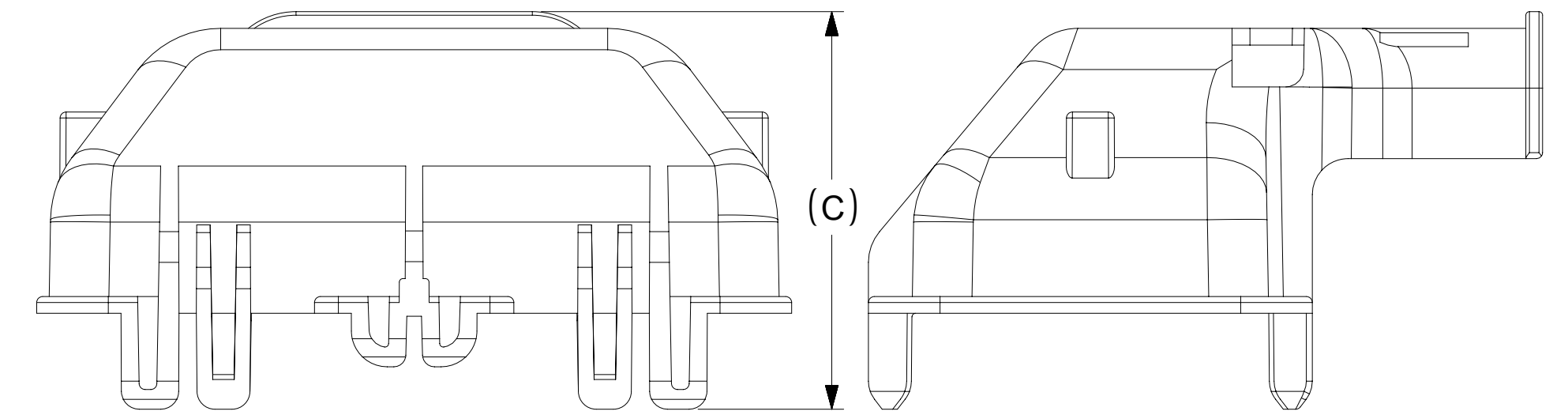
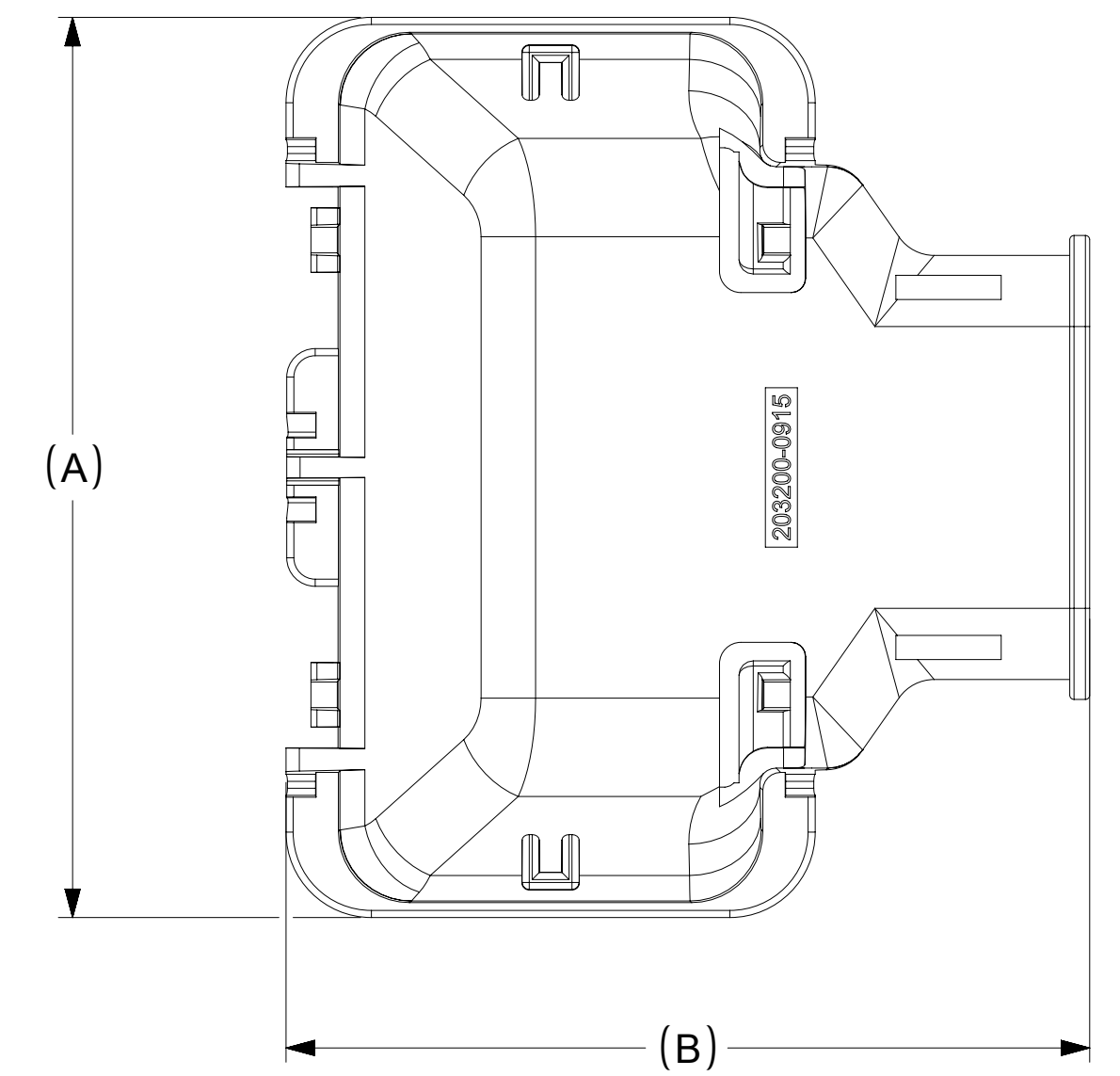

THIS DRAWING CONTAINS INFORMATION THAT IS PROPRIETARY TO MOLEX ELECTRONIC TECHNOLOGIES, LLC AND SHOULD NOT BE USED WITHOUT WRITTEN PERMISSION

QUALITY SYMBOLS F = 0 E = 0 D = 0 C = 0 B = 0 A = 0 X = 0 Y = 0	EC NO: 653738 DRWN: NBOHIDAR CHKD: BDICK01 REV/ APPR: BDICK01	2021/02/04 2021/06/18 2021/06/18	GENERAL TOLERANCES (UNLESS SPECIFIED) ANGULAR TOL ± ° 4 PLACES ± 3 PLACES ± 2 PLACES ± 1 PLACE ± 0 PLACES ± DRAFT WHERE APPLICABLE MUST REMAIN WITHIN DIMENSIONS	DIMENSION UNITS: mm SCALE: 2:1 DRWN BY: APROFFITT DATE: 2016/10/05 CHKD BY: SKRAJENDRANA DATE: 2016/11/04 APPR BY: VKOSHY DATE: 2016/11/04	DRAWING SIZE: D THIRD ANGLE PROJECTION	SERIES: 203200 MATERIAL NUMBER: CHARTED CUSTOMER:
	PRODUCT CUSTOMER DRAWING		molex			
	GPCM GENERAL MARKET WIRE DRESS COVER		DOCUMENT NUMBER: 2032000001-SD DOC TYPE: PSD DOC PART: 000 SHEET NUMBER: 3 OF 4			
	RELEASE STATUS: P1 RELEASE DATE: 2021/06/18 12:14:17					

