

8" LED ARCHITECTURAL CAN & FRAME IN KIT

Project:	
Type:	
Catalog #:	

STANDARD



The Energy Star CLADL8 series is a 8" commercial grade architectural can & frame in kit. Built for commercial use with architectural frames and a deep cone reflector for precision light. This high-efficiency luminaire provides long life - offered in two wattages and color temperatures.

FEATURES

- Architectural frames
- C channel and flat hanger bars for tie down to ceiling grids.
- 40 and 52 watts available in 4000K.
- Junction box is mounted on the frame for easy wiring, driver access for installation, and replacement.
- Diecast aluminum heatsink dissipates heat from the LED board.
- Self-flanged aluminum reflector with a frosted lens to shield direct view of LEDs.
- Universal 120-277 AC voltage (50/60Hz)
- 0-10V dimming
- Color rendering index ≥ 80 .
- Long life LEDs - up to 50,000hours.
- Operation Temp. $-30^{\circ}\text{C} \sim 40^{\circ}\text{C}$ ($-22^{\circ}\text{F} \sim 104^{\circ}\text{F}$).

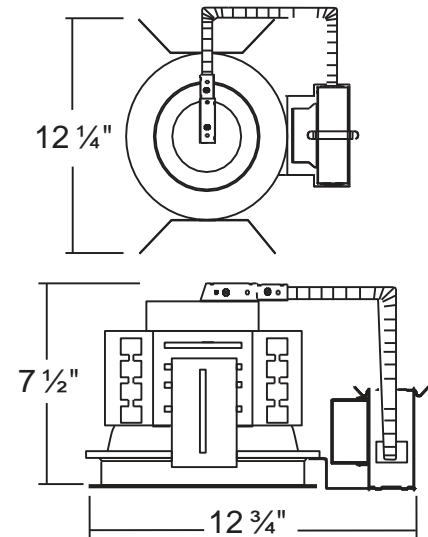

Image shown with trim & frame.

WARRANTY & LISTINGS

- cULus Listed.
- Energy star listed.
- Suitable for wet locations (not suitable for coastal/salt water area).
- Suitable for damp locations.
- RoHS compliant.
- 5-year warranty of all electronics and housing.

DIMENSIONS



ORDERING INFORMATION

Trim Models

Model	Color Temperature	Luminaire Lumens	Luminaire Watts	Lumens/Watt
CLADL8-4040-T	4000k	3090	40	77
CLADL8-5240-T	4000k	4530	52	87

Frame Models

Luminaire Wattage	Frame Required
40	CLADL8-4040-F
52	CLADL8-5240-F