



# N2Power XLM500 AC-DC High Efficiency Medical Power Supplies

## HIGHLIGHTS

- 500 W AC-DC
- High efficiency up to 94%
- With P.F.C. function > 0.94
- Built-in 12 V / 0.3 A fan supply
- Standby 5 V / 1 A with fan, 0.4 A without fan
- Open Frame, U-Frame, Enclosed models available
- 4000 VAC input to output 2xMOPP Insulation
- UL / IEC / EN 60601 3.1 Edition and UL / IEC / EN 60950 AM2 Safety Approvals
- UL / IEC/EN 62368-1 Safety Approvals
- Complying with the latest EMC standard EN60601-1-2: 2015 (4th edition)
- Maximum output: 500 W with 30 CFM fan or 240 W with unobstructed convection cooling
- EMI for both Class I (with PE) and Class II (without PE) configurations
- 3-year warranty



## OPERATING CHARACTERISTICS

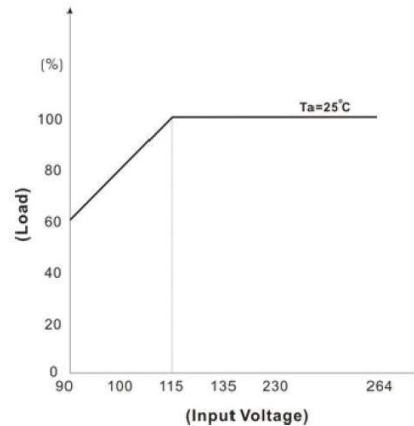
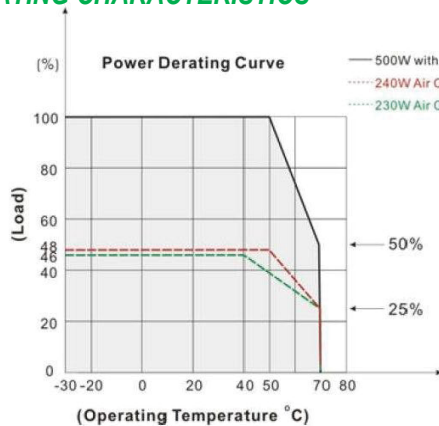

## BLOCK DIAGRAM

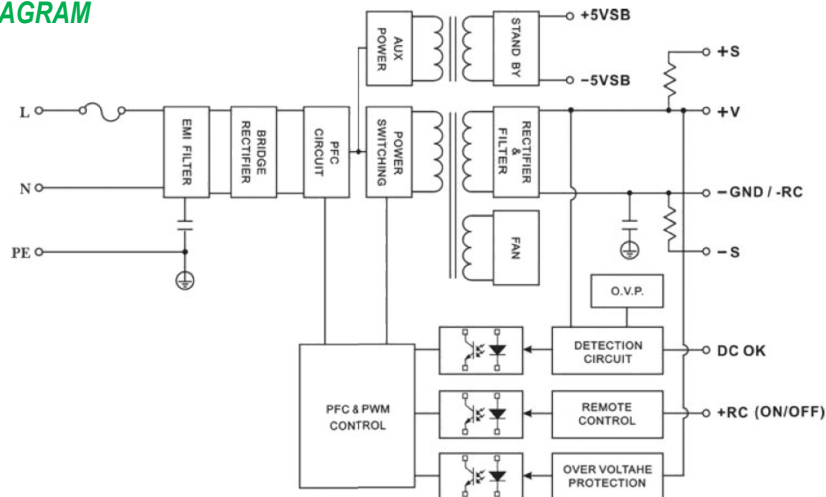

# N2Power XLM500 AC-DC

## High Efficiency Medical Power Supplies

MODEL	PART NUMBER	OUTPUT	VOLTAGE	REGULATION	MAXIMUM CURRENT (A)	RIPPLE & NOISE (P-P)
XLMO500-12	400525-05-2	VOUT	12	±3.5	41.5(1)	120 mV
XLMU500-12	400525-08-6	VOUT	12		19.16(2)	
XLME500-12	400525-11-0	VOUT	12		20(3)	
XLMO500-15	400525-14-3	VOUT	15	±3.5	33.3(1)	160 mV
XLMU500-15	400525-15-1	VOUT	15		15.33(2)	
XLME500-15	400525-16-9	VOUT	15		16.00(3)	
XLMO500-24	400525-06-0	VOUT	24	±3.5	20.8(1)	240 mV
XLMU500-24	400525-09-4	VOUT	24		9.58(2)	
XLME500-24	400525-12-8	VOUT	24		10(3)	
XLMO500-48	400525-07-8	VOUT	48	±3.5	10.41(1)	480 mV
XLMU500-48	400525-10-2	VOUT	48		4.8(2)	
XLME500-48	400525-13-6	VOUT	48		5(3)	

Note: If you can't find your preferred output voltage listed on the table above, please contact a sales representative. We can easily modify standard PSUs to meet client-specific voltage requirements.

All specifications valid at normal input voltage, full load and +25°C after warm-up time, unless otherwise stated. XLMO models are Open Frame, XLMU models are U-Frame and XLME models are Enclosed.

### Compliance\*

#### Safety:

UL / IEC / EN 60601-1 3.1 Edition, UL / IEC / EN 60950-1 AM2, UL/IEC/EN 62368-1

#### EMC:

EN Standard	EN60601-1-2:2015 (4th Edition)
Conducted EMI (7)	EN55011 Class B
Radiated EMI (7)	EN55011 Class A
Radiated Immunity	EN61000-4-3
Fast Transient	EN61000-4-4
Conducted Immunity	EN61000-4-6
PFMF	EN61000-4-8
Interruption	EN61000-4-11

#### Notes

- (1) With 30CFM fan
- (2) Convection cooling at 115VAC
- (3) Convection cooling at 230VAC
- (4) Ripple & Noise are measured at 20MHz of bandwidth with 0.1uF & 47uF parallel capacitor.
- (5) Hold-up Time measured at 90% Vout.
- (6) Please check the derating curve for more details.
- (7) Please secure the power supply unit to your metal case by using the four screw holes in the corners for either Class I or Class II equipment
- (8) The fan supply is designed to serve as the source of the additive external fan for the cooling of the power supply, enabling the full load delivery and assuring the best life span of the product. Please do not use this fan supply to drive other devices.

**This product is not designed for use in critical life support systems, equipment used in hazardous environment, nuclear control systems or other such applications which necessitate specific safety and regulatory standards other than the ones listed in this datasheet.**

\*Every effort has been made to keep the information contained in this document current and accurate as of the date of publication or revision. However, no guarantee is given or implied that the document is error-free or that it is accurate with regard to any specification. N2Power reserves the right to change specifications without notice. Qualstar and the Qualstar logo are registered trademarks of Qualstar Corporation. N2Power and the N2Power logo are trademarks of Qualstar Corporation. All other trademarks are the property of their respective owners.

INPUT SPECIFICATIONS	
Nominal Input Voltage <sup>(6)</sup>	90 – 264 VAC or 127 – 370 VDC
Input Frequency Range	47 – 63 Hz
Input Current	< 6.3 A max. @ 115 VAC < 3.15 A max. @ 230 VAC
Safety Isolation	4000 VAC input to output 2000 VAC input to ground 1500 VAC output to gnd.
Inrush Current	< 40 A max. @ 115 VAC < 80 A max. @ 230 VAC
Leakage Current	< 0.1mA max (Input-Output)
Power Factor @ 230VAC	> 0.94 at full load
OUTPUT SPECIFICATIONS	
Total Output	500 W <sup>(1)</sup> 230 W <sup>(2)</sup> 240 W <sup>(3)</sup>
Output Voltages	12 to 48 V
Voltage Tolerance	±2%
Line Regulation	±0.5% (115- 264 VAC)
Load Regulation	±1% (0-100%, typical)
Hold-up Time <sup>(5)</sup>	Min. 8 ms @115VAC
Efficiency	Up to 93%
Minimum Load	3%
PROTECTION	
Over Voltage Protection:	Auto recovery
Over Power Protection:	Auto recovery, hiccup mode
Over Temperature:	Auto recovery
Short Circuit Protection:	Auto recovery, hiccup mode
ENVIRONMENTAL SPECIFICATIONS	
Operating Temperature:	-30 to +70°C (with derating)
Storage Temperature:	- 35 to +85°C
Relative Humidity:	20% to 90% (non-cond.)
MTBF (full load at 25°C):	> 160,000 hours @ 25°C (MIL-HDBK-217F, Notice 1)
Vibration	10-500Hz, 2G 10min./1cycle, 60min. each along X, Y, Z axes.
FAN SUPPLY (OPEN FRAME AND U-FRAME MODELS) <sup>(8)</sup> AND 5VSB	
Fan Supply Voltage	12V
Voltage Tolerance	10.2V~13.3V (0.1A minimum load)
Maximum Current	0.3A
5VSB	5V
Voltage Tolerance	4.2V ~ 5.5V
Maximum Current	1A with fan 0.4A without fan

Contact us regarding custom and modified standard supplies for unique applications. For complete specifications on all models, please visit our website at [N2Power.com](http://N2Power.com)

# N2Power XLM500 AC-DC

## High Efficiency Medical Power Supplies

### MECHANICAL DRAWINGS – Open Frame Models

Unit: [inch] mm

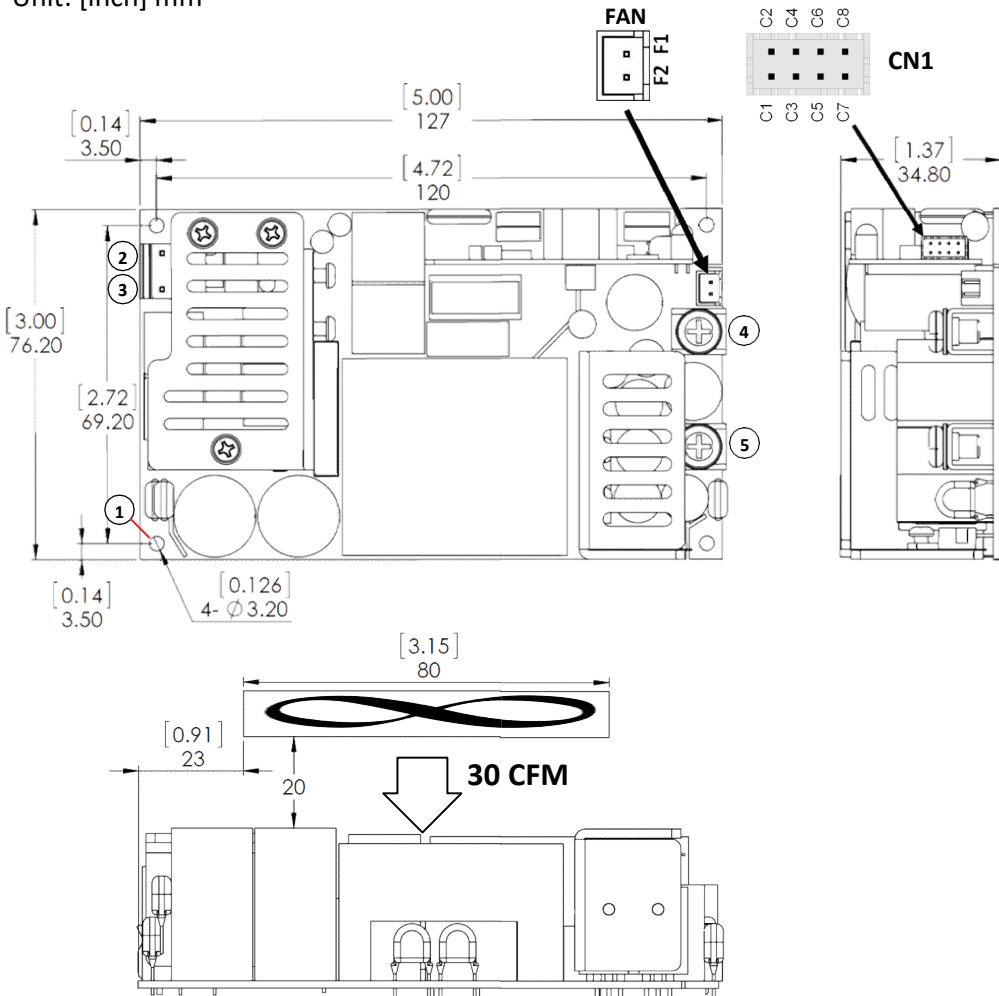

PIN#	Assignment
1	FG
2	AC NEUTRAL
3	AC LINE
4	VOUT (+OUTPUT)
5	RTN (RETURN)

FAN CONNECTOR	
PIN#	Assignment
F1	+12V (fan supply)
F2	RTN (RETURN)

CN1	
PIN#	Assignment
C1	RTN (RETURN)
C2	+5VSB
C3	RTN (RETURN)
C4	DC_OK
C5	RTN (RETURN)
C6	ENABLE
C7	-RS
C8	+RS

Contact us regarding custom and modified standard supplies for unique applications.  
For complete specifications on all models, please visit our website at [N2Power.com](http://N2Power.com)

All information and specifications are based on our knowledge of the products at the time of printing.  
N2Power reserves the right to change specifications without notice.

© Copyright 2020 | Qualstar Corporation | All rights reserved





# N2Power XLM500 AC-DC

## High Efficiency Medical Power Supplies

### MECHANICAL DRAWINGS – U-Frame Models

Unit: [inch] mm

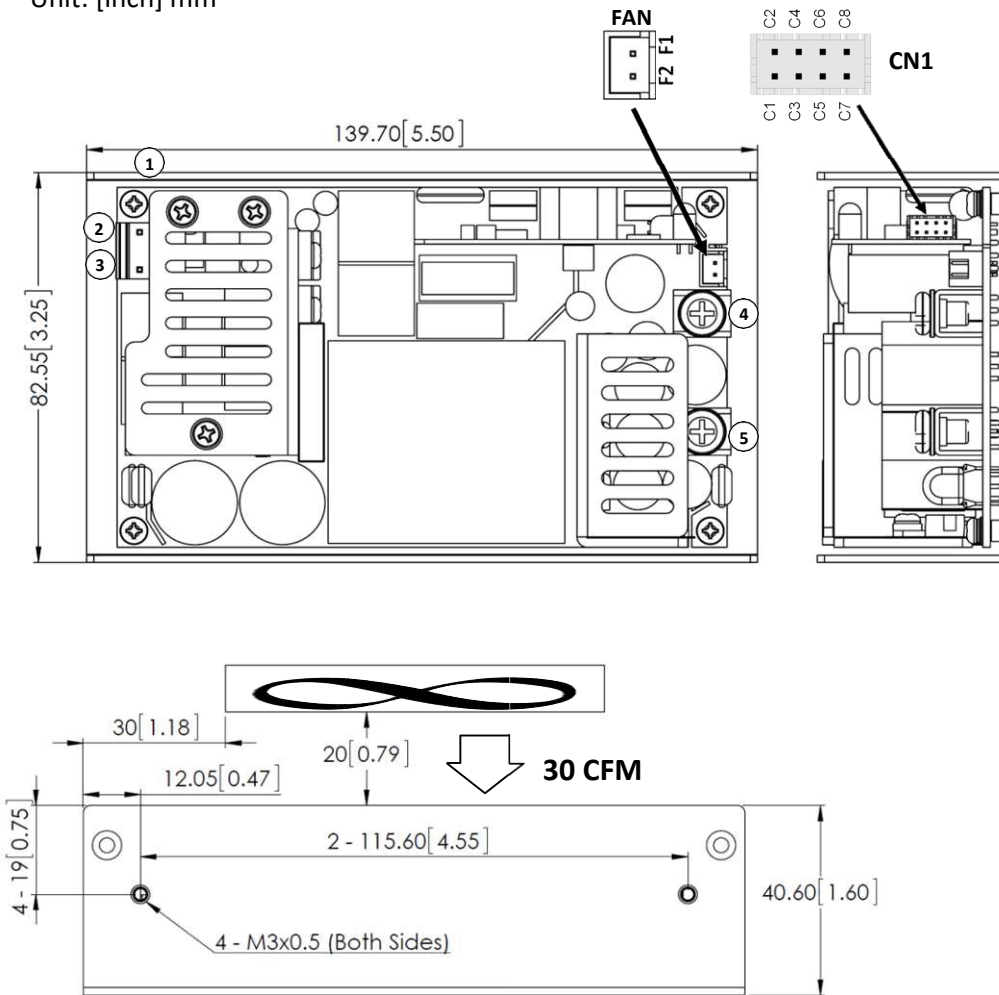

PIN#	Assignment
1	FG
2	AC NEUTRAL
3	AC LINE
4	VOUT (+OUTPUT)
5	RTN (RETURN)

FAN CONNECTOR	
PIN#	Assignment
F1	+12V (fan supply)
F2	RTN (RETURN)

CN1	
PIN#	Assignment
C1	RTN (RETURN)
C2	+5VSB
C3	RTN (RETURN)
C4	DC_OK
C5	RTN (RETURN)
C6	ENABLE
C7	-RS
C8	+RS

Contact us regarding custom and modified standard supplies for unique applications. For complete specifications on all models, please visit our website at [N2Power.com](http://N2Power.com)

All information and specifications are based on our knowledge of the products at the time of printing. N2Power reserves the right to change specifications without notice.

© Copyright 2020 | Qualstar Corporation | All rights reserved



Call 805.583.7744

[N2Power.com](http://N2Power.com)

Continued on next page...

# N2Power XLM500 AC-DC

## High Efficiency Medical Power Supplies

### MECHANICAL DRAWINGS – Enclosed Models

Unit: [inch] mm

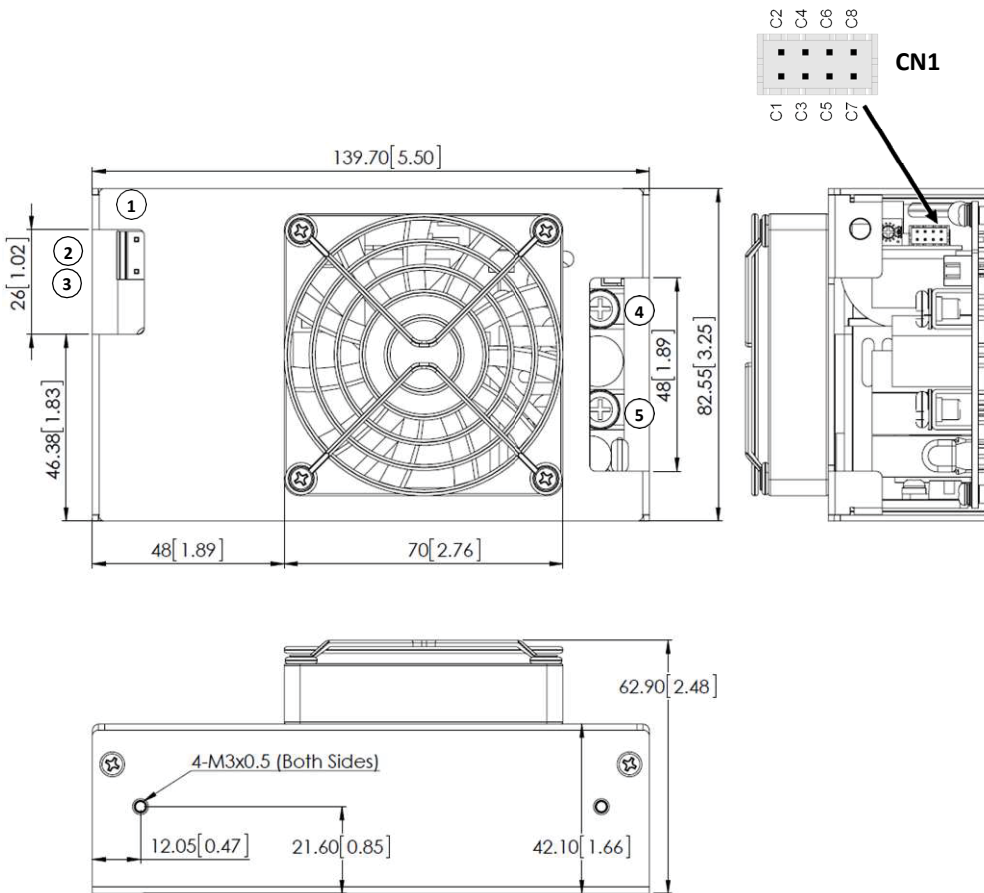

PIN#	Assignment
1	FG
2	AC NEUTRAL
3	AC LINE
4	VOUT (+OUTPUT)
5	RTN (RETURN)

CN1	
PIN#	Assignment
C1	RTN (RETURN)
C2	+5VSB
C3	RTN (RETURN)
C4	DC_OK
C5	RTN (RETURN)
C6	ENABLE
C7	-RS
C8	+RS

Pin No.	Function	Description
C1	RTN (RETURN)	This pin connects to the RTN (Return) of VOUT, DC-OK and ENABLE (Remote Enable).
C2	+5VSB	Stand by voltage : 4.2~5.5V with respect to RTN. The maximum load current is 1A with Fan, 0.4A without Fan.
C3	RTN (RETURN)	This pin connects to the RTN (Return) of VOUT, DC-OK and ENABLE (Remote Enable).
C4	DC_OK	DC-OK Signal is a DC output with respect to RTN.
C5	RTN (RETURN)	This pin connects to the RTN (Return) of VOUT, DC-OK and ENABLE (Remote Enable).
C6	ENABLE	Turns the output on and off by electrical or dry contact between pin C6 (ENABLE) and RTN. Short: Power OFF, Open: Power ON.
C7	-RS	Negative Remote Sense. The -RS signal should be connected to the negative terminal of the load. The +RS and -RS leads should be twisted in pair to minimize noise pick-up effect.
C8	+RS	Positive Remote Sense. The +RS signal should be connected to the positive terminal of the load. The +RS and -RS leads should be twisted in pair to minimize noise pick-up effect.

Contact us regarding custom and modified standard supplies for unique applications.  
For complete specifications on all models, please visit our website at [N2Power.com](http://N2Power.com)

All information and specifications are based on our knowledge of the products at the time of printing.  
N2Power reserves the right to change specifications without notice.

© Copyright 2020 | Qualstar Corporation | All rights reserved



E211115 E469416



Call 805.583.7744

[N2Power.com](http://N2Power.com)