

DO NOT
SCALE FROM
THIS PRINT

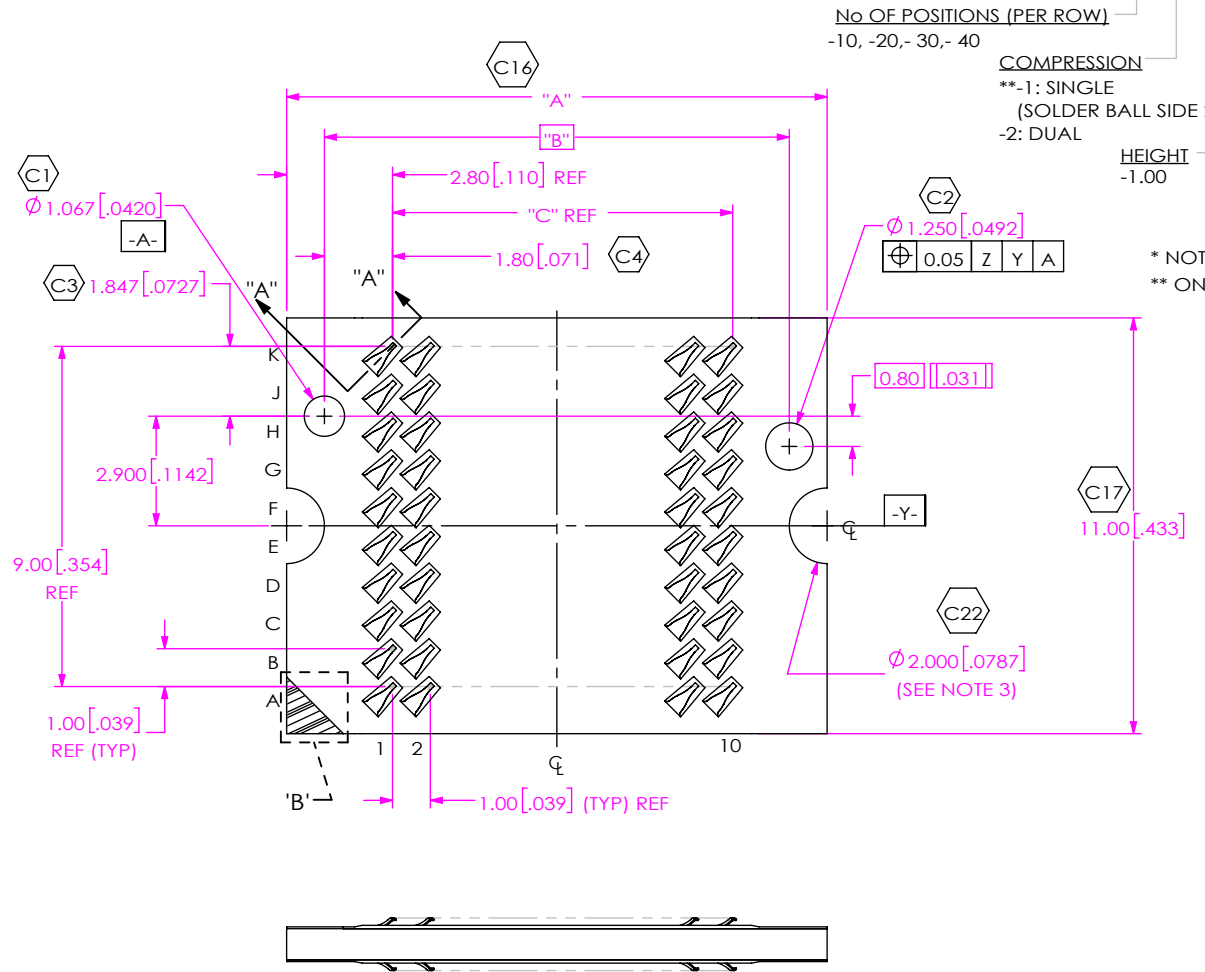

No OF POSITIONS (PER ROW)
-10, -20, -30, -40

COMPRESSION
** -1: SINGLE
(SOLDER BALL SIDE 2)
-2: DUAL

HEIGHT
-1.00

SOLDER COMPOSITION
LEAVE BLANK FOR -2 COMPRESSION
-2: LEAD-FREE (96.5% Sn/3% Ag/.5% Cu)

ROW SPECIFICATION
-10: 10 ROWS

PLATING SPECIFICATION
-Z: 6µ" MIN Au (C15) OVER 40-100µ" Ni (C20)
-S: 30µ" MIN Au (C15) OVER 40-100µ" Ni (C20)

* NOT RELEASED
** ONLY AVAILABLE IN -10 & -20 POSITIONS

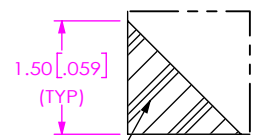
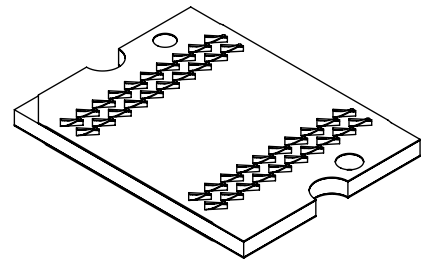

POSITION 1 INDICATOR THROUGH COVERFILM ONLY
DETAIL 'B'
SCALE 10 : 1



FIG 1
ZA1-10-2-1.00-X-10 SHOWN
(DUAL COMPRESSION)
(SOME CENTER FEATURES REMOVED FOR CLARITY)

TABLE 1			
No OF POS	"A"	"B"	"C"
-10	14.30 [.563]	12.300 [.4843]	9.00 [.354]
-20	24.30 [.957]	22.300 [.8780]	19.00 [.748]
-30	38.30 [1.508]	36.300 [1.4291]	33.00 [1.299]
-40	48.30 [1.902]	46.300 [1.8228]	43.00 [1.693]

- NOTES:
- ⊗ REPRESENTS A CRITICAL DIMENSION.
 - CONTACT POINTS ARE MEASURED IN UNCOMPRESSED STATE.
 - RECOMMENDED SCREW SIZE: M1.6
100% ISOLATION & CONTINUITY TESTS REQUIRED
100% HI-POT REQUIRED AT 300V
MINIMUM PIN TO PIN ISOLATION TO BE 200 MEGA OHMS
 - PARTS TO BE PACKAGED IN TRAYS.
 - DIMENSION AFTER FINAL REFLOW IS 1.000[.0394].
 - MAXIMUM BURR AFTER DICING: 0.125[.005].
 - PARTS TO BE PROCESSED PER SAMTEC WORKMANSHIP GUIDELINES: NA-ZR-WI-3015-M.
 - PAD SIZE IS DEFINED BY SOLDERMASK OPENING; SOLDERMASK THICKNESS IS 0.0254±0.0127mm.
 - TOTAL STACK HEIGHT OF MATERIAL LAYERS IS REPRESENTED IN CONTACT ARRAY AREA. AREAS OUTSIDE OF THE ARRAY HAVE THE FOIL LAYER REMOVED RESULTING IN THINNER PROFILE DIMENSION OUTSIDE OF ARRAY.

UNLESS OTHERWISE SPECIFIED, DIMENSIONS ARE IN MILLIMETERS.
TOLERANCES ARE:
DECIMALS ANGLES
X.X: ±0.3 [.01] 2°
X.XX: ±0.13 [.005]
X.XXX: ±0.051 [.0020]

PROPRIETARY NOTE
THIS DOCUMENT CONTAINS CONFIDENTIAL AND PROPRIETARY INFORMATION AND ALL DESIGN, MANUFACTURING, REPRODUCTION, USE, PATENT RIGHTS AND SALES RIGHTS ARE EXPRESSLY RESERVED BY SAMTEC, INC. THIS DOCUMENT SHALL NOT BE DISCLOSED, IN WHOLE OR PART, TO ANY UNAUTHORIZED PERSON OR ENTITY NOR REPRODUCED, TRANSFERRED OR INCORPORATED IN ANY OTHER PROJECT IN ANY MANNER WITHOUT THE EXPRESS WRITTEN CONSENT OF SAMTEC, INC.

MATERIAL: DO NOT SCALE DRAWING SHEET SCALE: 2:1
CONTACT: BeCu
CORE: FR4
COVERLAY: POLYIMIDE

F:\DWG\MISC\MKTG\ZA1-XX-X-X.XX-X-XX-X-MKT.SLDDRW

520 PARK EAST BLVD. NEW ALBANY, IN 47150
PHONE: 812-944-6733 FAX: 812-948-5047
e-Mail: info@SAMTEC.com code 55322

DESCRIPTION:
1.0mm PITCH ZRAY ASSEMBLY

DWG. NO.
ZA1-XX-X-X.XX-X-XX-X

BY: D.SCHMELZ 01/08/2014 SHEET 1 OF 6

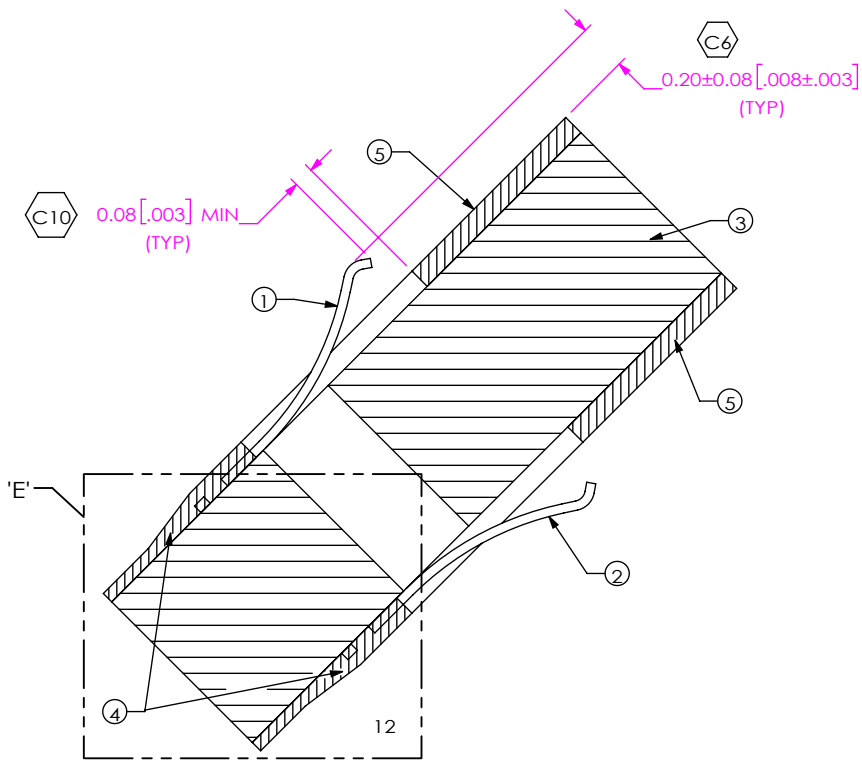

SECTION "A"-"A"
SCALE 32 : 1

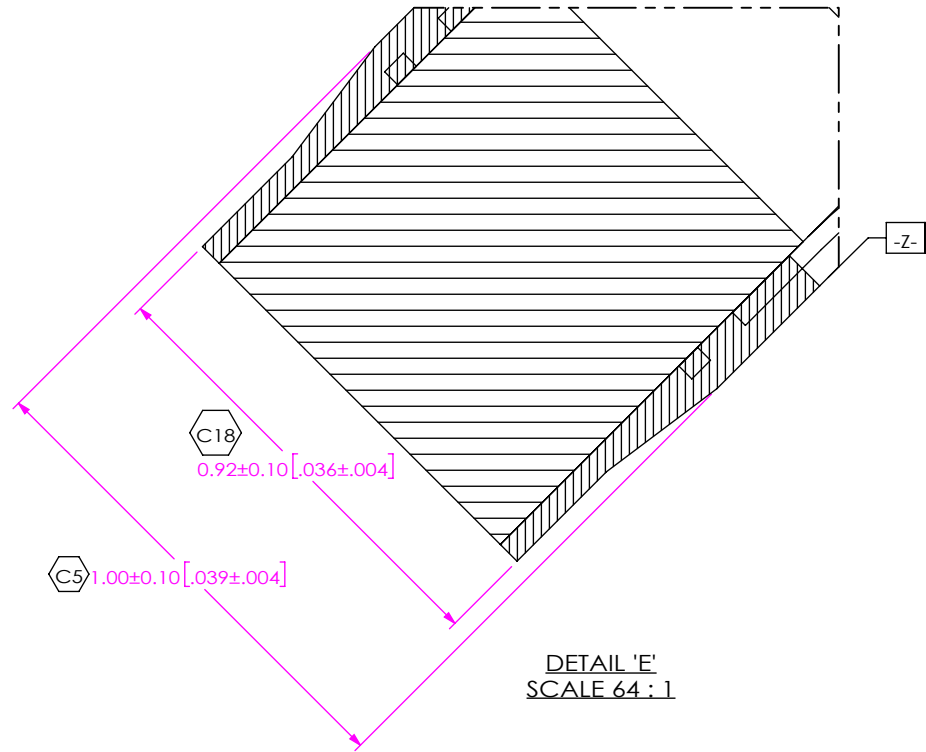

DETAIL 'E'
SCALE 64 : 1

ZA1-XX-2-X.XX-X-XX-X BOM

ITEM NO.	PART NUMBER	DESCRIPTION	10X10 QTY	20X10 QTY	30X10 QTY	40X10 QTY	MATERIAL
1	FOIL-0002-NS-01	CONTACT	.01111	.01667	.03333	.03333	BeCu
2	FOIL-0002-FS-01	CONTACT	.01111	.01667	.03333	.03333	BeCu
3	PCB-(SEE TABLE 2)	CORE	.01111	.01667	.03333	.03333	FR4
4	FR1515-6X9-0002	BOND PLY	.02222	.03333	.06667	.06667	A DHESIV E/POLYIMIDE FILM
5	ZCF-BL03-FR01-1209-BK	COVERFILM	.01111	.01667	.03333	.03333	A DHESIV E/POLYIMIDE FILM
6	TRAY-(SEE TABLE 2)	TRAY	.02500	.02857	.04000	.05000	CLEAR ESD COA TED RPET

TABLE 2

No OF POS	COMPRESSON	PCB-106543-ZA1-XX-10-01	CAM DATA	TRAY
-10	-2	PCB-106543-ZA1-10-10-01	ZR-00011	TY-ZA1001
-20	-2	PCB-106543-ZA1-20-10-01	ZR-00012	TY-ZA1002
-30	-2	PCB-106543-ZA1-30-10-01	ZR-00013	TY-ZA1003
-40	-2	PCB-106543-ZA1-40-10-01	ZR-00014	TY-ZA1004

PROPRIETARY NOTE

THIS DOCUMENT CONTAINS CONFIDENTIAL AND PROPRIETARY INFORMATION AND ALL DESIGN, MANUFACTURING, REPRODUCTION, USE, PATENT RIGHTS AND SALES RIGHTS ARE EXPRESSLY RESERVED BY SAMTEC, INC. THIS DOCUMENT SHALL NOT BE DISCLOSED, IN WHOLE OR PART, TO ANY UNAUTHORIZED PERSON OR ENTITY NOR REPRODUCED, TRANSFERRED OR INCORPORATED IN ANY OTHER PROJECT IN ANY MANNER WITHOUT THE EXPRESS WRITTEN CONSENT OF SAMTEC, INC.

DO NOT SCALE DRAWING

SHEET SCALE: 3:1



520 PARK EAST BLVD, NEW ALBANY, IN 47150
PHONE: 812-944-6733 FAX: 812-948-5047
e-Mail info@SAMTEC.com code 55322

DESCRIPTION: 1.0mm PITCH ZRAY ASSEMBLY

DWG. NO. ZA1-XX-X-X.XX-X-XX-X

BY: D.SCHMELZ 01/08/2014 SHEET 2 OF 6

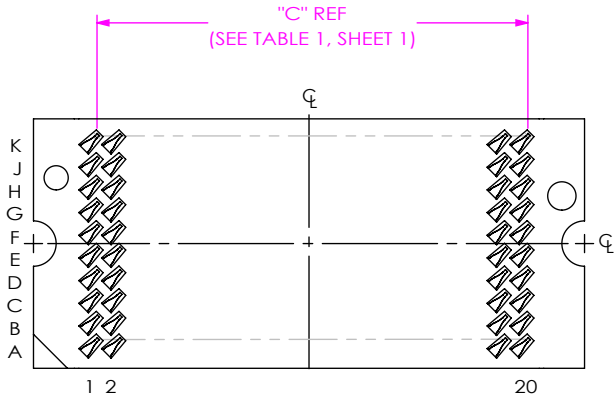

FIG 2
 ZA1-20-2-1.00-X-10 SHOWN
 (DUAL COMPRESSION)
 (DIFFERENT AS SHOWN, OTHERWISE SAME AS FIG 1)
 (SOME CENTER FEATURES REMOVED FOR CLARITY)

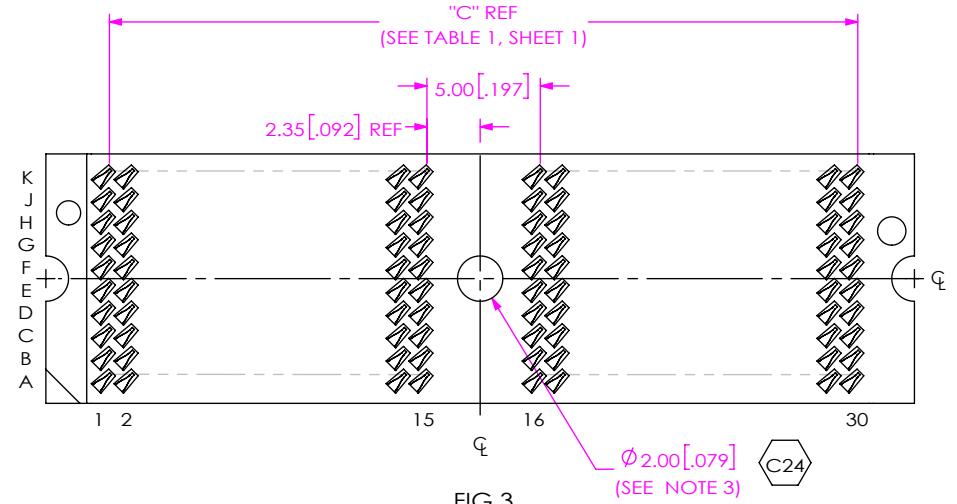

FIG 3
 ZA1-30-2-1.00-X-10 SHOWN
 (DUAL COMPRESSION)
 (DIFFERENT AS SHOWN, OTHERWISE SAME AS FIG 1)
 (SOME CENTER FEATURES REMOVED FOR CLARITY)

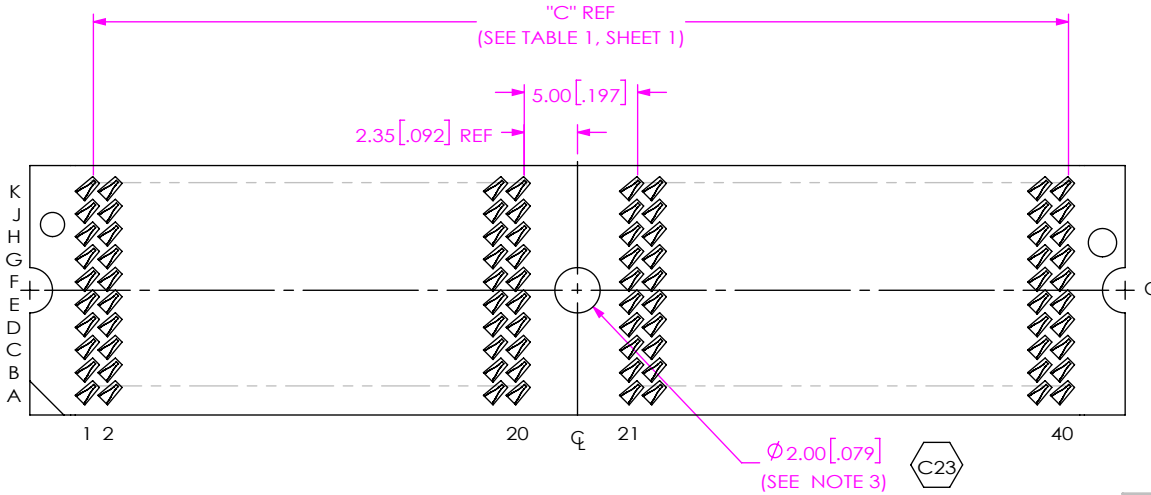

FIG 4
 ZA1-40-2-1.00-X-10 SHOWN
 (DUAL COMPRESSION)
 (DIFFERENT AS SHOWN, OTHERWISE SAME AS FIG 1)
 (SOME CENTER FEATURES REMOVED FOR CLARITY)

PROPRIETARY NOTE
 THIS DOCUMENT CONTAINS CONFIDENTIAL AND PROPRIETARY INFORMATION AND ALL DESIGN, MANUFACTURING, REPRODUCTION, USE, PATENT RIGHTS AND SALES RIGHTS ARE EXPRESSLY RESERVED BY SAMTEC, INC. THIS DOCUMENT SHALL NOT BE DISCLOSED, IN WHOLE OR PART, TO ANY UNAUTHORIZED PERSON OR ENTITY NOR REPRODUCED, TRANSFERRED OR INCORPORATED IN ANY OTHER PROJECT IN ANY MANNER WITHOUT THE EXPRESS WRITTEN CONSENT OF SAMTEC, INC.

DO NOT SCALE DRAWING

SHEET SCALE: 3:1



520 PARK EAST BLVD, NEW ALBANY, IN 47150
 PHONE: 812-944-6733 FAX: 812-948-5047
 e-Mail info@SAMTEC.com code 55322

DESCRIPTION:
 1.0mm PITCH ZRAY ASSEMBLY

DWG. NO.
ZA1-XX-X-X.XX-X-XX-X

BY: D.SCHMELZ 01/08/2014 SHEET 3 OF 6

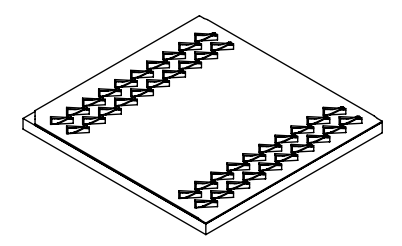
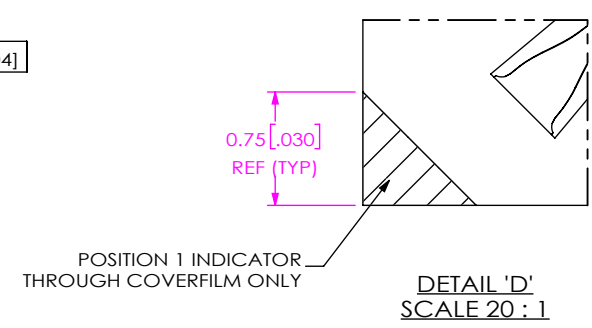
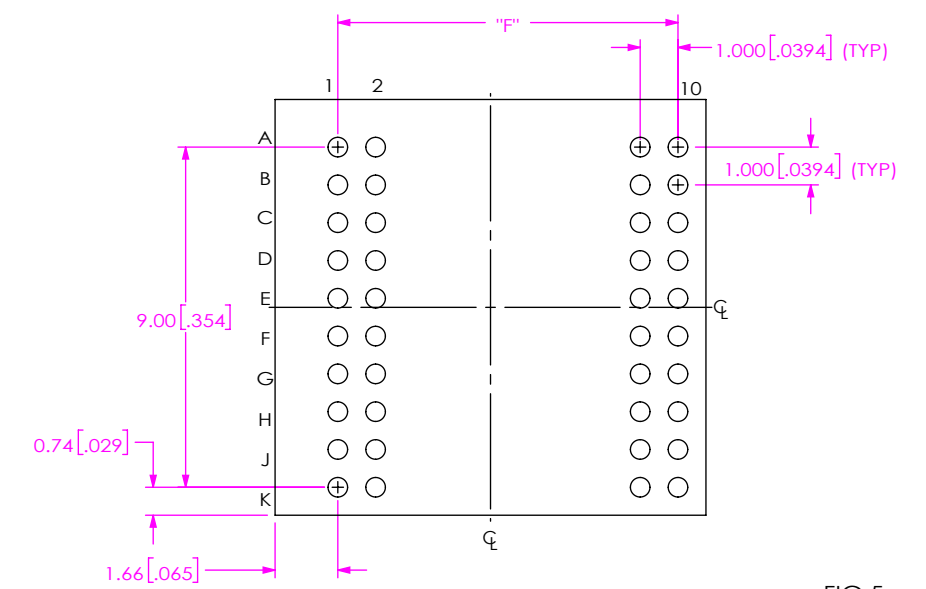
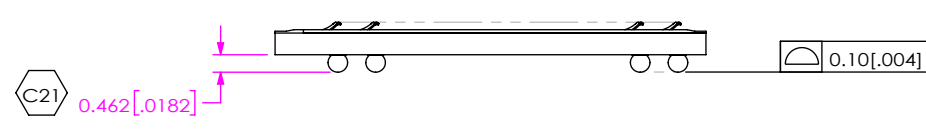
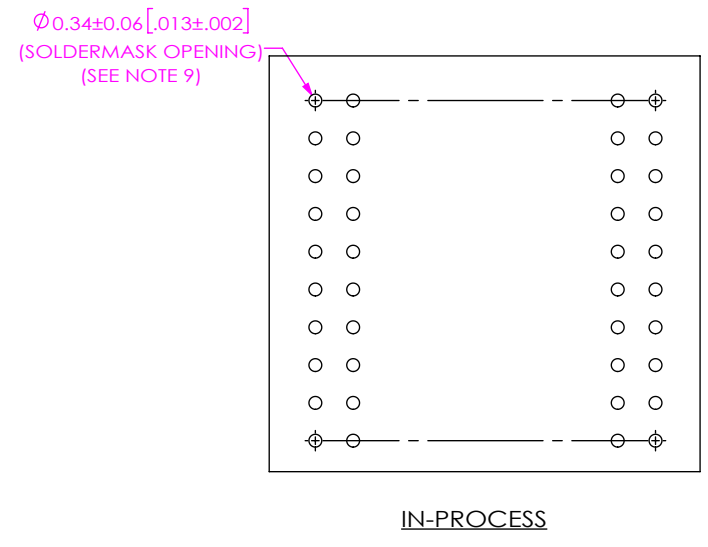
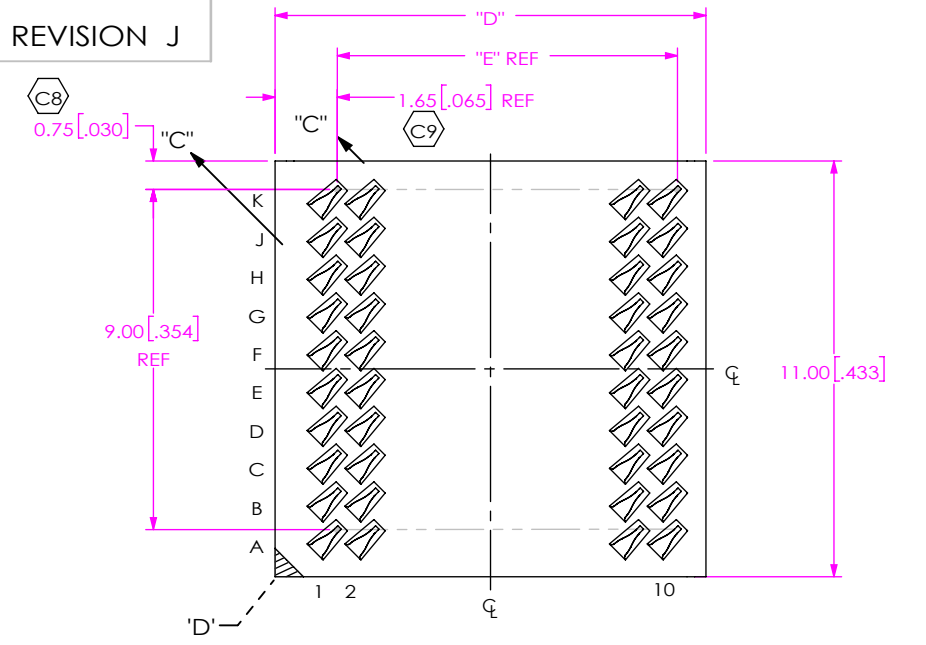

TABLE 4

No OF POS	"D"	"E"	"F"
-10	11.40 [0.449]	9.00 [0.354]	9.00 [0.354]
-20	21.40 [0.843]	19.00 [0.748]	19.00 [0.748]

FIG 5
 ZA1-10-1-1.00-X-10-X SHOWN
 (SINGLE COMPRESSION)
 (DIFFERENT AS SHOWN, OTHERWISE SAME AS FIG 1)
 (SOME CENTER FEATURES REMOVED FOR CLARITY)

PROPRIETARY NOTE
 THIS DOCUMENT CONTAINS CONFIDENTIAL AND PROPRIETARY INFORMATION AND ALL DESIGN, MANUFACTURING, REPRODUCTION, USE, PATENT RIGHTS AND SALES RIGHTS ARE EXPRESSLY RESERVED BY SAMTEC, INC. THIS DOCUMENT SHALL NOT BE DISCLOSED, IN WHOLE OR PART, TO ANY UNAUTHORIZED PERSON OR ENTITY NOR REPRODUCED, TRANSFERRED OR INCORPORATED IN ANY OTHER PROJECT IN ANY MANNER WITHOUT THE EXPRESS WRITTEN CONSENT OF SAMTEC, INC.

DO NOT SCALE DRAWING
 SHEET SCALE: 5:1

520 PARK EAST BLVD, NEW ALBANY, IN 47150
 PHONE: 812-944-6733 FAX: 812-948-5047
 e-Mail info@SAMTEC.com code 55322

DESCRIPTION:
 1.0mm PITCH ZRAY ASSEMBLY

DWG. NO.
ZA1-XX-X-X.XX-X-XX-X

BY: D.SCHMELZ 01/08/2014 SHEET 4 OF 6

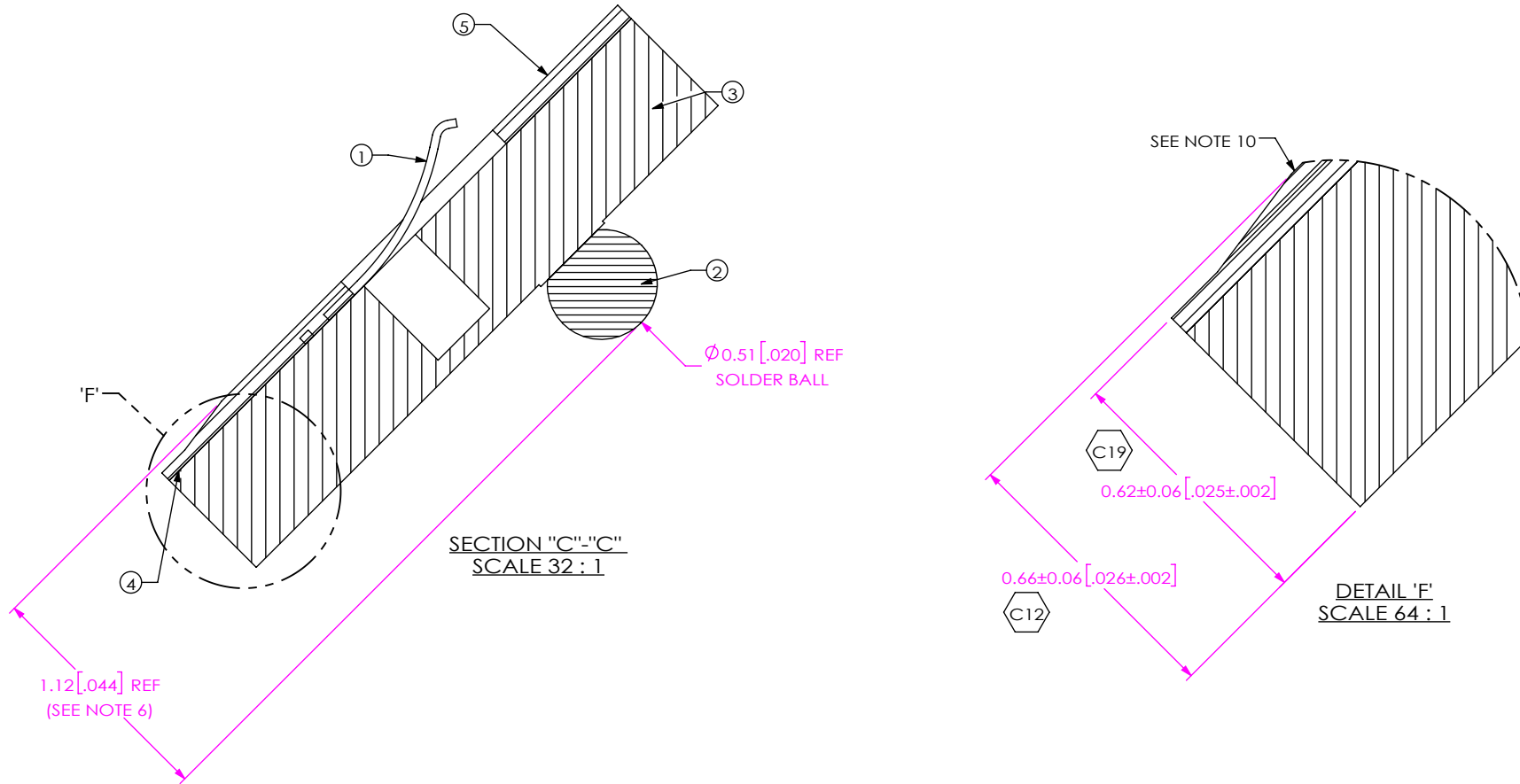

ZA1-XX-1-X.XX-X-XX-X BOM							
ITEM NO.	PART NUMBER	DESCRIPTION	10X10 QTY	20X10 QTY	30X10 QTY	40X10 QTY	MATERIAL
1	FOIL-0002-NS-01	CONTACT	.00667	.01667	.03333	.03333	BeCu
2	SDB-020-9653	SOLDER BALL	100	200	300	400	SEE CALLOUT
3	PCB-(SEE TABLE 3)	CORE	.00667	.01667	.03333	.03333	FR4
4	LF1535-6X9-0002	BOND PLY	.00667	.01667	.03333	.03333	ADHESIVE/POLYIMIDE FILM
5	ZCF-BL03-FR01-1209-BK	COVERFILM	.00334	.00834	.01667	.01667	ADHESIVE/POLYIMIDE FILM
6	PPP-77-11.00	P & P PAD	1	1	1	1	LCP
7	TRAY-(SEE TABLE 3)	TRAY	.02500	.02857	.04000	.05000	CLEAR ESD COATED RPET

TABLE 3				
No OF POS	COMPRESSION	PCB-106859-ZA1-XX-XX-01	CAM DATA	TRAY
-10	-1	PCB-106859-ZA1-10-10-01	ZR-00015	TY-ZA1005
-20	-1	PCB-106859-ZA1-20-10-01	ZR-00039	TY-ZA1006

PROPRIETARY NOTE
 THIS DOCUMENT CONTAINS CONFIDENTIAL AND PROPRIETARY INFORMATION AND ALL DESIGN, MANUFACTURING, REPRODUCTION, USE, PATENT RIGHTS AND SALES RIGHTS ARE EXPRESSLY RESERVED BY SAMTEC, INC. THIS DOCUMENT SHALL NOT BE DISCLOSED, IN WHOLE OR PART, TO ANY UNAUTHORIZED PERSON OR ENTITY NOR REPRODUCED, TRANSFERRED OR INCORPORATED IN ANY OTHER PROJECT IN ANY MANNER WITHOUT THE EXPRESS WRITTEN CONSENT OF SAMTEC, INC.

DO NOT SCALE DRAWING

SHEET SCALE: 5:1



520 PARK EAST BLVD, NEW ALBANY, IN 47150
 PHONE: 812-944-6733 FAX: 812-948-5047
 e-Mail info@SAMTEC.com code 55322

DESCRIPTION: 1.0mm PITCH ZRAY ASSEMBLY
 DWG. NO. ZA1-XX-X-X.XX-X-XX-X
 BY: D.SCHMELZ 01/08/2014 SHEET 5 OF 6

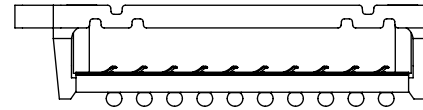
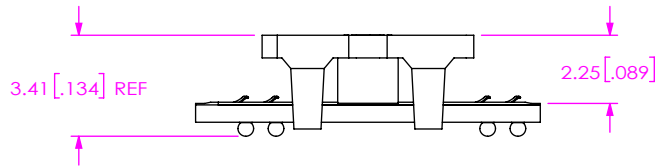
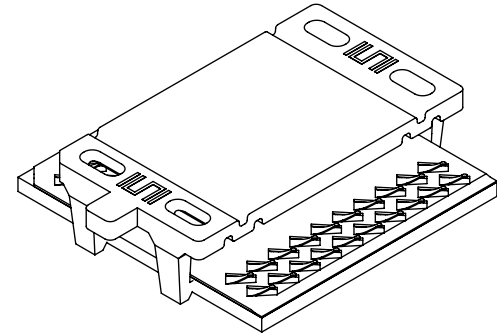
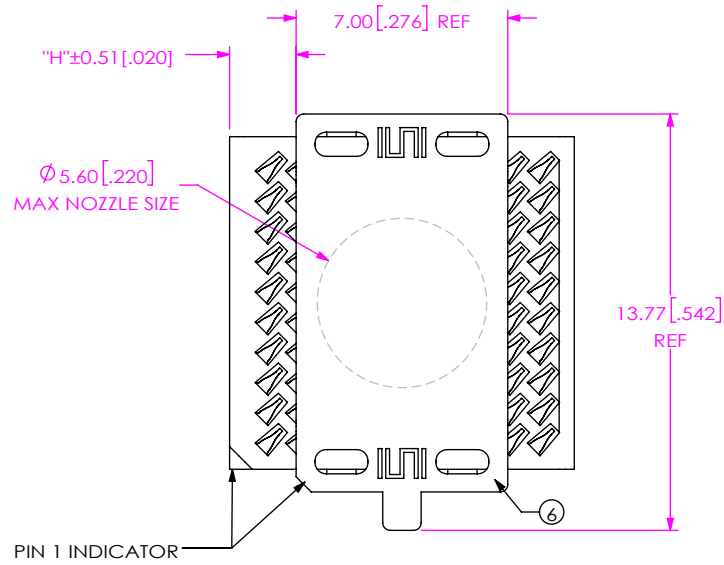

FIG 7
 ZA1-10-1-1.00-X-10-X SHOWN
 (SINGLE COMPRESSION WITH PPP)
 (DIFFERENT AS SHOWN, OTHERWISE SAME AS FIG 6)
 (SOME CENTER FEATURES REMOVED FOR CLARITY)

No OF POS	"H"
-10	2.20 [.087]
-20	7.20 [.283]

PROPRIETARY NOTE
 THIS DOCUMENT CONTAINS CONFIDENTIAL AND PROPRIETARY INFORMATION AND ALL DESIGN, MANUFACTURING, REPRODUCTION, USE, PATENT RIGHTS AND SALES RIGHTS ARE EXPRESSLY RESERVED BY SAMTEC, INC. THIS DOCUMENT SHALL NOT BE DISCLOSED, IN WHOLE OR PART, TO ANY UNAUTHORIZED PERSON OR ENTITY NOR REPRODUCED, TRANSFERRED OR INCORPORATED IN ANY OTHER PROJECT IN ANY MANNER WITHOUT THE EXPRESS WRITTEN CONSENT OF SAMTEC, INC.

DO NOT SCALE DRAWING

SHEET SCALE: 3:1



520 PARK EAST BLVD, NEW ALBANY, IN 47150
 PHONE: 812-944-6733 FAX: 812-948-5047
 e-Mail info@SAMTEC.com code 55322

DESCRIPTION:
 1.0mm PITCH ZRAY ASSEMBLY

DWG. NO.
ZA1-XX-X-X.XX-X-XX-X

BY: D.SCHMELZ 01/08/2014 SHEET 6 OF 6