

THIS DRAWING IS UNPUBLISHED. RELEASED FOR PUBLICATION
 © COPYRIGHT - By - ALL RIGHTS RESERVED.

REVISIONS					
P	LTR	DESCRIPTION	DATE	DWN	APVD
D2		REVISED PER ECO-12-015539	28AUG12	KH	DR
D3		REVISED PER ECO-17-008808	31JAN2018	RS	DR

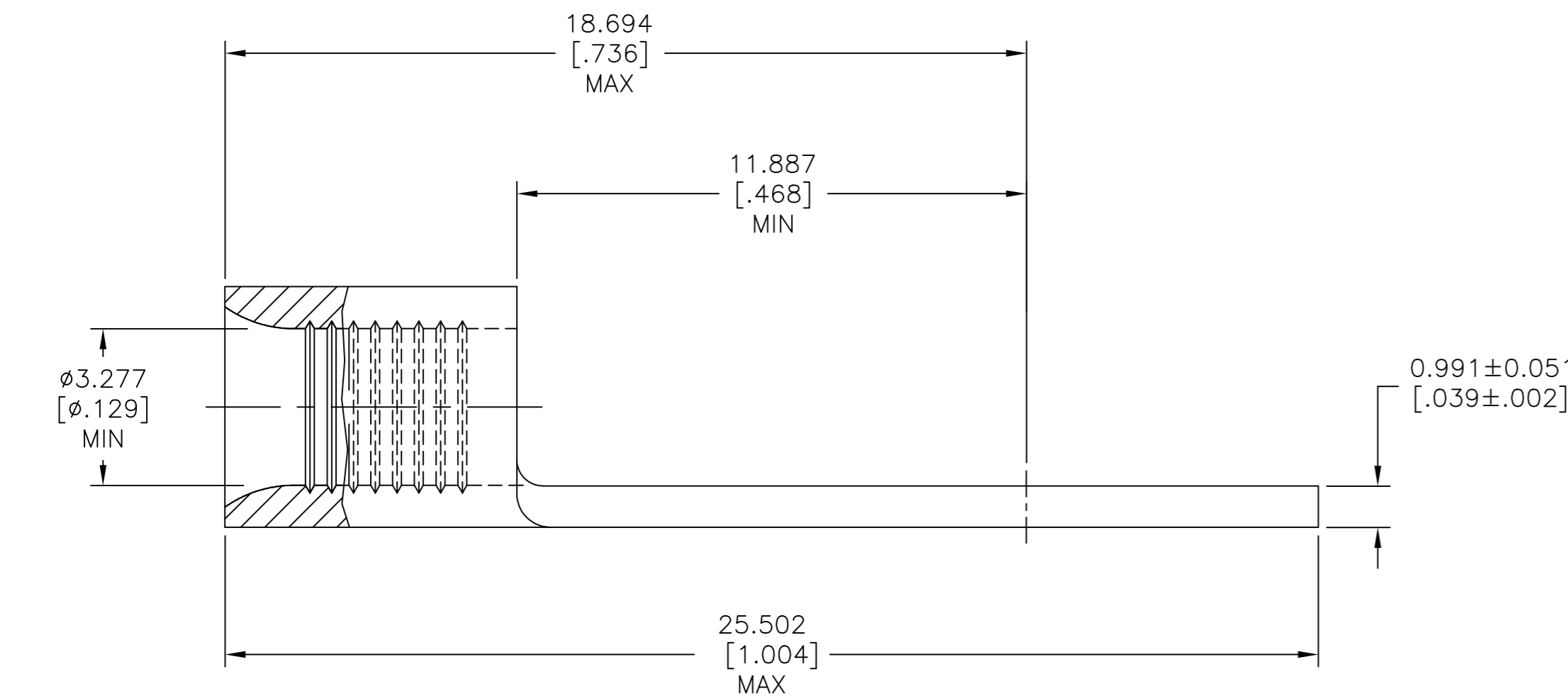
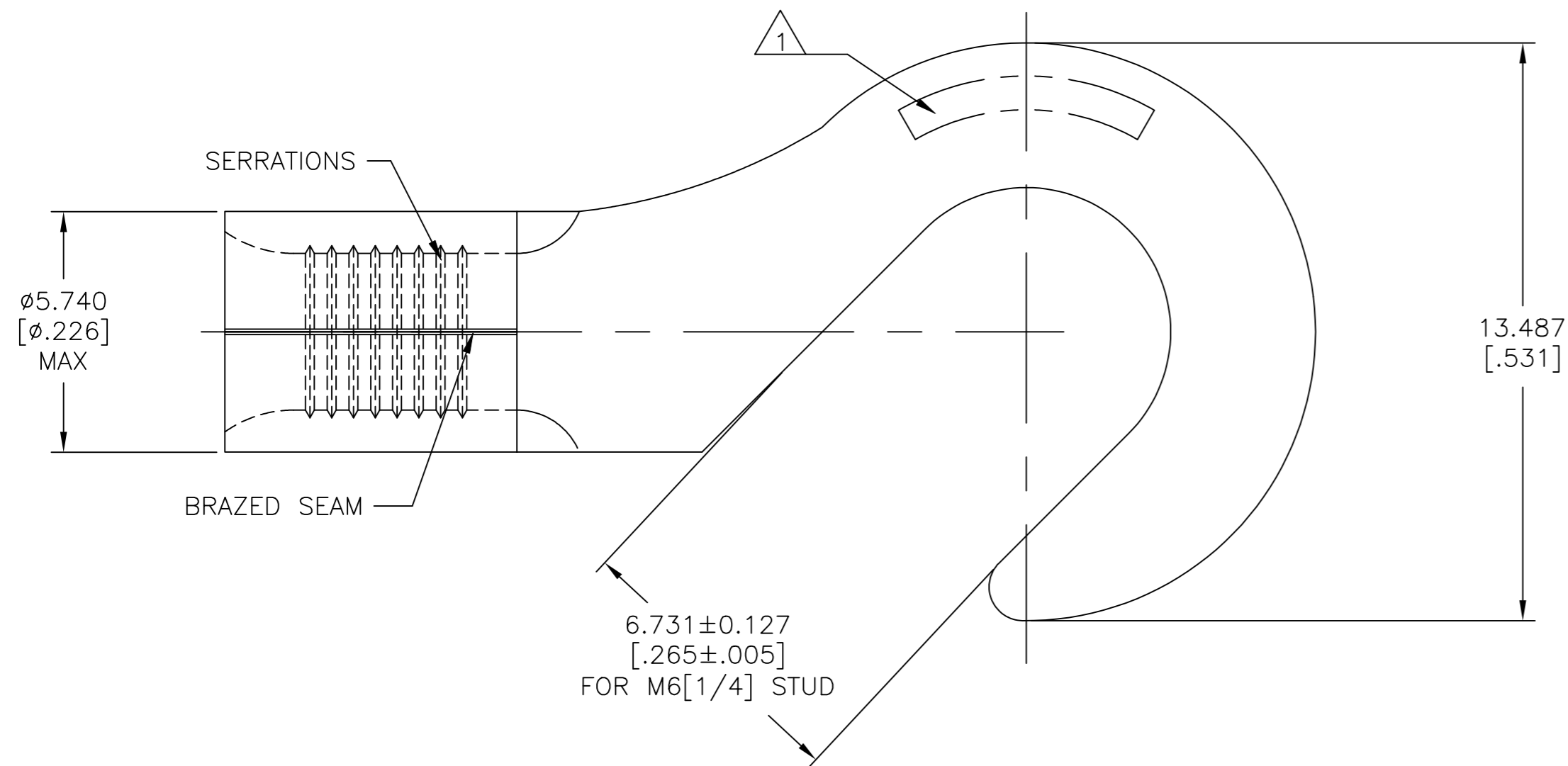

AMP WIRE RANGE	E13288 Listed
12-10 AWG SOLID OR STRANDED	12-10 AWG SOLID OR STRANDED
LR7189 Certified	MILITARY P/N AND CLASS
12-10 AWG SOLID OR STRANDED	NOT APPLICABLE

- 1 STAMP AMP 12-10* APPROX AS SHOWN
- 2 TIN PLATE 0.00254[.000100] MIN EXT THICK PER ASTM B545
- 3 NOTE DELETED
- 4 NOTE DELETED
- 5 MAX RECOMMENDED OPERATING TEMPERATURE IS 170°C [338°F] MAX.

AMP INCORPORATED
 CUSTOMER SERVICE SYSTEMS

MAX RECOMMENDED OPERATING TEMPERATURE:
 5

FOR ADDITIONAL
 PRODUCT INFORMATION OR
 COPIES OF DRAWINGS
 AND TECHNICAL DOCUMENTS

PRODUCT INFORMATION CENTER
 1-800-522-6752

VOLTAGE RATING:
 NOT APPLICABLE

FOR APPLICATION
 TOOLING INFORMATION

TOOLING ASSISTANCE CENTER
 1-800-722-1111

WIRE CROSS SECTIONAL AREA RANGE:
 2.62-6.64mm² [5,180-13,100] CIR MILS
 SOLID OR STRANDED

FOR ORDER ENTRY

1-800-526-5142

THIS DRAWING IS A CONTROLLED DOCUMENT FOR
 AMP INCORPORATED. IT IS SUBJECT TO CHANGE
 AND THE CONTROLLING ENGINEERING ORGANIZATION
 SHOULD BE CONTACTED FOR THE LATEST REVISION.

5	2	500	LOOSE PIECE	321632
QUANTITY		PACKAGING TYPE		PART NO

THIS DRAWING IS A CONTROLLED DOCUMENT.		DWN TA BRINKMAN 4-8-93	TE Connectivity Ltd.	
DIMENSIONS: mm [INCHES]		CHK DA PATTERSON 4-8-93	NAME	
TOLERANCES UNLESS OTHERWISE SPECIFIED:		APVD DE MILLER 4-8-93	PRODUCT SPEC	
0 PLC ± -		UL 486 A-B		
1 PLC ± -		APPLICATION SPEC		
2 PLC ± -		SIZE		
3 PLC ± 0.127[.005]		CAGE CODE		
4 PLC ± -		DRAWING NO		
ANGLES ± -		RESTRICTED TO		
FINISH		WEIGHT		
MATERIAL COPPER PER ASTM B-152 ANNEALED		A2 00779 C=321632		
2		CUSTOMER DRAWING		
		SCALE 8:1 SHEET 1 of 1 REV D3		