

# CSM Series

## Board Mount Heat Sink For TO-220 Devices



The economically priced CSM Series is suitable for use with TO-220 devices found in active components as well as power resistors. With surface areas ranging from 1188 Sq. mm to 6645 Sq. mm, the CSM family comes in 5 configurations, all of them with Black Anodized surface treatment. These heatsinks

offer a range of thermal performance from 18.0 to 9.8 C/W. Each device offers solder able mounting feet and anywhere from 1, 2 or 3 mounting holes are available for convenient device attachment.

### SERIES SPECIFICATIONS

Heatsink Part Number	Surface Area (in <sup>2</sup> / mm <sup>2</sup> )	Weight (oz / g)	Length L (mm)	Thermal Res.* (°C/W)
CSM221-12AE	1.84 / 1,188	0.13 / 3.7	12	18.0
CSM221-28AE	4.30 / 2,772	0.3 / 8.5	28	12.8
CSM221-40AE	6.14 / 3,960	0.43 / 12.2	40	12.1
CSM222-30AE	6.25 / 4,029	0.5 / 14.2	30	11.3
CSM223-50AE†	10.30 / 6,645	0.6 / 17.0	50	9.8

\*Free convection at 10 watts dissipation

†Available for custom orders only, not offered as standard length

### CHARACTERISTICS

#### Heat Dissipation

Heat dissipation is the total for ALL DEVICES attached to the heat sink

**Heat Sink** Aluminum Alloy 6063-T5 or Equivalent with either degeared or black anodized finish.

**Solder Foot** Cold-rolled Steel, surface tin plated.

**Interface Thermal Resistance** for improvement, use thermal joint compound, 0.005 Grafoil (TGon 800 by Laird), or phase change material (Hi-Flow by Bergquist)

**Insulator** (Optional) Sil-Pad 900-S, K6 800-S and K10 by Bergquist

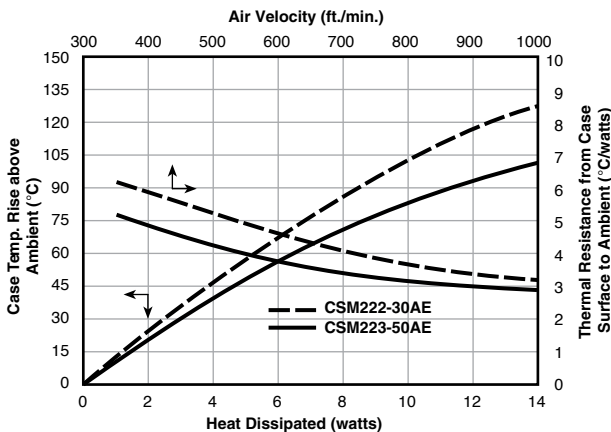
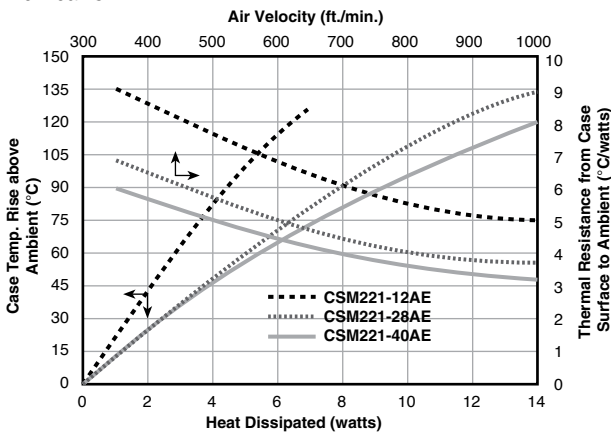

(continued)

# CSM Series

## Board Mount Heat Sink For TO-220 Devices

### DIMENSIONS

Dimensions in mm; M3\*0.5P thread Tapping. JIS-2b standard chamfer 0.3m

CSM221-12AE

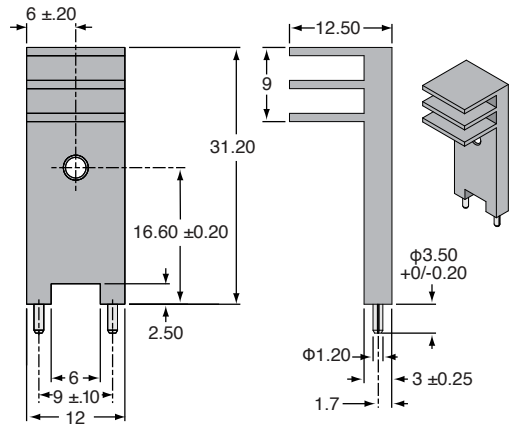

CSM221-40AE

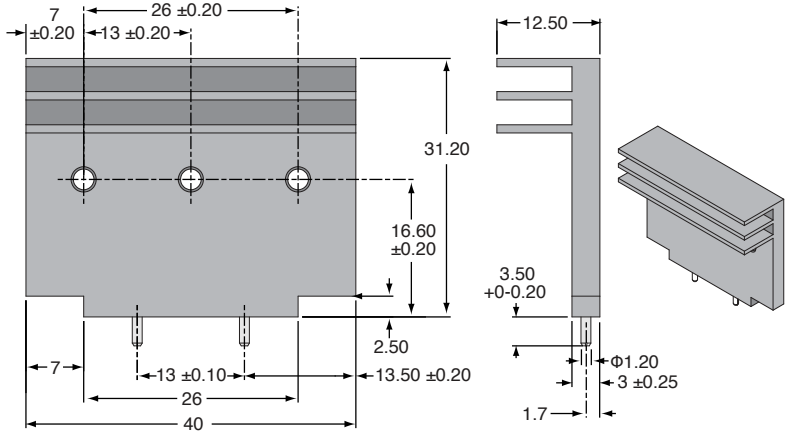

CSM221-28AE

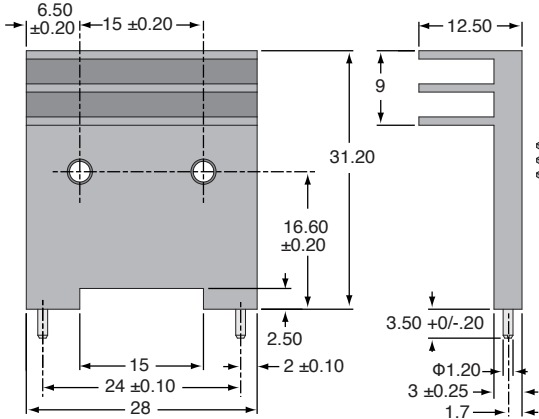

CSM222-30AE

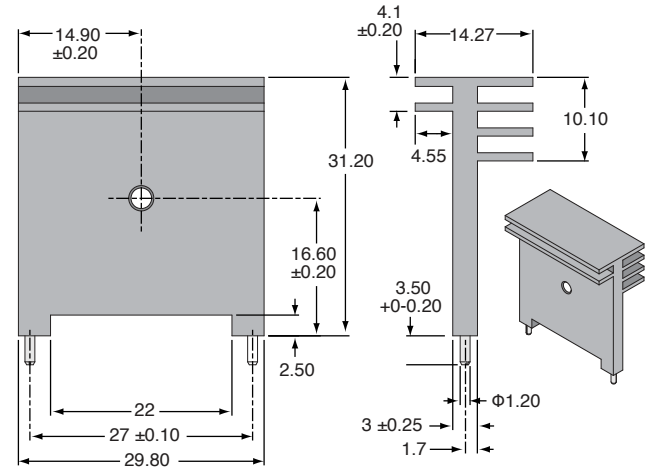

CSM223-50AE\*

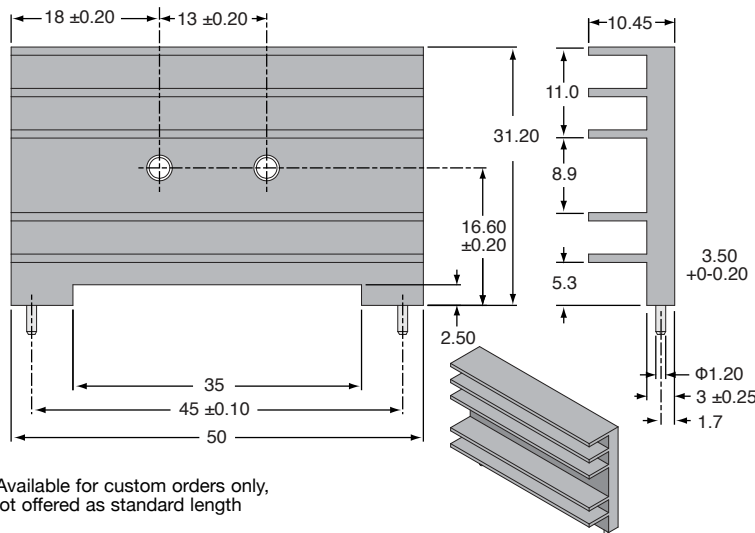

\*Available for custom orders only, not offered as standard length

rev 1/20-1

### HOW TO ORDER

RoHS Compliant  
**C S M 2 2 1 - 1 2 A E**  
 Series      Extrusion type      Extrusion width      Black anodized