

- 1
- 2
- 3
- 4
- 5
- 6
- 7
- 8
- 9
- 10
- 11
- 12
- 13
- 14
- 15
- 16
- 17
- 18

**BODY**

Transparent polyamide based (PA-T) technopolymer. Highly resistant to shocks, solvents, oils with additives, aliphatic and aromatic hydrocarbons, petrol, naphtha, phosphoric esters.  
Avoid contact with alcohol or detergents containing alcohol.

**PACKING RINGS**

Step-shaped for the seal on the reservoir walls and NBR synthetic rubber O-ring screw underhead.  
Suggested roughness of the packing ring application surface Ra = 3 µm.

**CONTRAST SCREEN**

White lacquered aluminium. The housing, in the appropriate external rear slot, guarantees the best protection from direct contact with fluid. It can be taken out from the inclined side, before assembly to allow the insertion of level lines or words.

**STANDARD EXECUTIONS**

- **HCZ:** zinc-plated steel screws, nuts and washers.
- **HCZ-VT:** AISI 303 stainless steel screws, AISI 304 stainless steel nuts and washers.

**MAXIMUM CONTINUOUS WORKING TEMPERATURE**

90°C (with oil).

**FEATURES AND PERFORMANCES**

Ultrasound welding to guarantee a perfect seal.  
Maximum fluid level visibility even from side positions.  
Lens effect for a better visibility of the fluid level.  
Thanks to the SUPER-technopolymer screws, HCZ-VT column level indicator can be used in corrosion resistance applications where stainless steel is not necessary.  
The special slotted head of the SUPER-technopolymer screws is especially designed to reach an optimum tightening of the packing rings by applying an adequate tightening torque (ELESA patent) thus avoiding unnecessary stress to the screws.

**TECHNICAL DATA**

In laboratory tests carried out with mineral oil type CB68 (according to ISO 3498) at 23°C for a limited period of time, the weld stood up to: 18 bar (HCZ.76 e HCZ.127) 12 bar (HCZ.254).  
Considering the SUPER-technopolymer screws, the maximum working pressure cannot be higher than 5 bar at 20°C and 2 bar at 90°C.  
For use with other fluids and under different pressure and temperature conditions, please contact ELESA Technical Department.  
In any case we suggest to verify the suitability of the product under the actual working conditions.

Conversion Table	
1 mm = 0.039 inch	
mm	inch
76	2.99
127	5.00
254	10.00



ELESA Original design

Drilling template  
Holes without burrs and chamfer

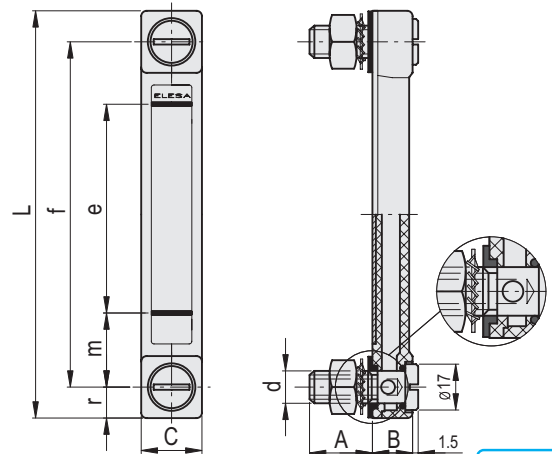
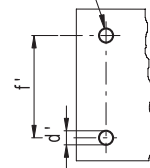

**HCZ.**

Code	Description	f	d	A	B	C	L	e	m	r	d <sup>-0.2</sup>	f <sup>±0.2</sup>	C# [Nm]	⚖
11382	HCZ.76-M10	76	M10	22	15	22	99	40	18	11.5	10.5	76	12	90
11385	HCZ.127-M12	127	M12	22	15	22	150	80	23	11.5	12.5	127	12	120
11388	HCZ.254-M12	254	M12	22	15	24	278	203	25	12.5	12.5	254	12	150

**HCZ-VT**

Code	Description	f	d	A	B	C	L	e	m	r	d <sup>-0.2</sup>	f <sup>±0.2</sup>	C# [Nm]	⚖
111382	HCZ.76-VT-M12	76	M12	23.5	15	22	99	40	18	11.5	12.5	76	6	67
111385	HCZ.127-VT-M12	127	M12	23.5	15	22	150	80	23	11.5	12.5	127	6	78
111388	HCZ.254-VT-M12	254	M12	23.5	15	24	278	203	25	12.5	12.5	254	6	110

Accessories for hydraulic systems

2 # Maximum tightening torque.