

RoHS

REV.	DESCRIPTION	DATE
A	RELEASE	2018/8/17

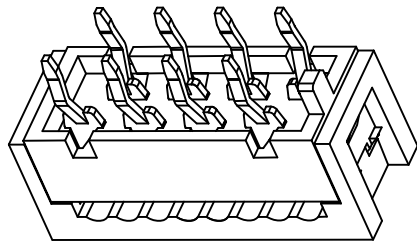
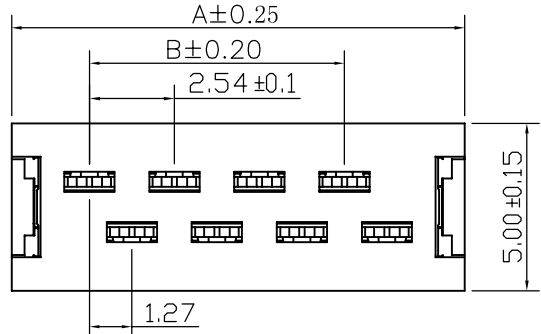

MATERIAL&FINISH
 Insulator: PBT Glass Fiber(UL94V-0)
 Contact : Phosphor bronze
 Contact : Sn Over Ni.

ELECTRICAL CHARACTERISTICS:
 Current Rating: 1 Amp
 Contact Resistance: 20MΩ Max
 Withstanding Voltage: 500V AC/Min
 Insulation Resistance: 1000MΩ Min
 Temperature Range: -40° C To+105° C

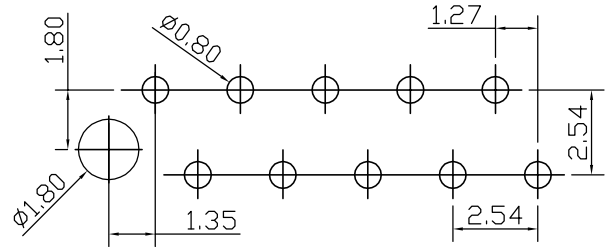
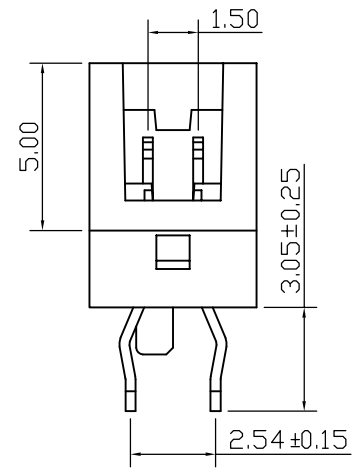
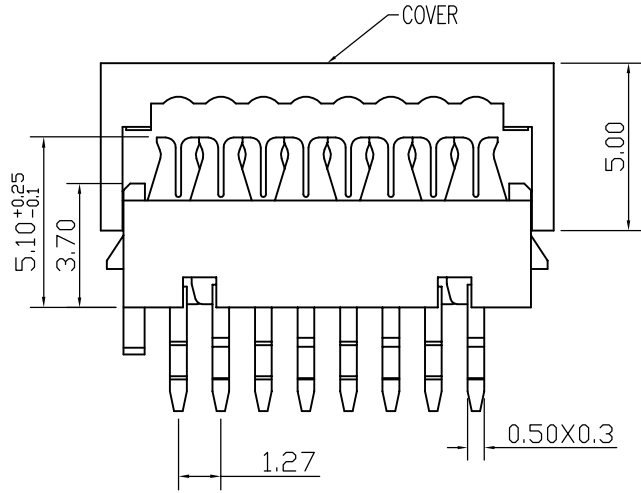

Recommended P.C. Board Layout

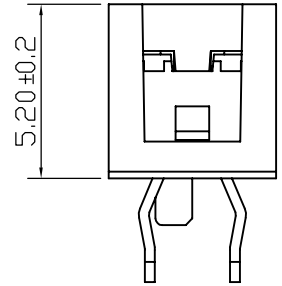

part number	POLES	DIMA	DIM.B	Q'ty/Tray
3550-04-0101-99	04	8.45	2.54	372
3550-06-0101-99	06	10.99	5.08	288
3550-08-0101-99	08	13.53	7.62	228
3550-10-0101-99	10	16.07	10.16	192
3550-12-0101-99	12	18.61	12.7	168
3550-14-0101-99	14	21.15	15.24	144
3550-16-0101-99	16	23.69	17.78	132
3550-18-0101-99	18	26.23	20.32	120
3550-20-0101-99	20	28.77	22.86	108
3550-22-0101-99	22	31.31	25.40	96
3550-24-0101-99	24	33.85	27.94	84
3550-26-0101-99	26	36.39	30.48	84

UNLESS TOLERANCE		DRAW BY	杨国祥
GENERAL	ANGLE	DESIGN BY	袁刚
X. ± 0.38	X.' ± 3.0°	CHECK BY	
.X ± 0.30	.X' ± 2.0°	APPROVE BY	
.XX ± 0.25	.XX' ± 1.0°	SCALE	SHEET
.XXX ± 0.10	.XXX' ± 0.5°	1:1	1/1
		UNIT	MM

CnC Tech,LLC

ITEM : Paddle Board Connector

DRW NO: 3550-XX-0101-99 REV: A0