

# SPECIFICATION CONTROL DRAWING

THIS DRAWING CONTAINS INFORMATION PROPRIETARY TO RF INDUSTRIES, LTD. ANY UNAUTHORIZED USE OF THIS DRAWING IS EXPRESSLY PROHIBITED. ANY VIOLATION IS PUNISHABLE UNDER U.S. COPYRIGHT LAWS.

REV	DESCRIPTION	DWN	DATE	APPROVED
A	ENGINEERING RELEASE	WMD	1/19/94	C. JONES
B	CHANGE DIELECTRICS & BODY ID \ ADD PRESS FIT WASHER	KMM	8/18/97	R. RICE
C	CHANGE CONTACT, PIN & DIELECTRIC DIMENSIONS	CZS	4/12/99	R. RICE
D	CHANGE FERRULE CONFIGURATION	CZS	12/8/99	R. RICE

000000

ALL DIMENSIONS ARE REFERENCE ONLY

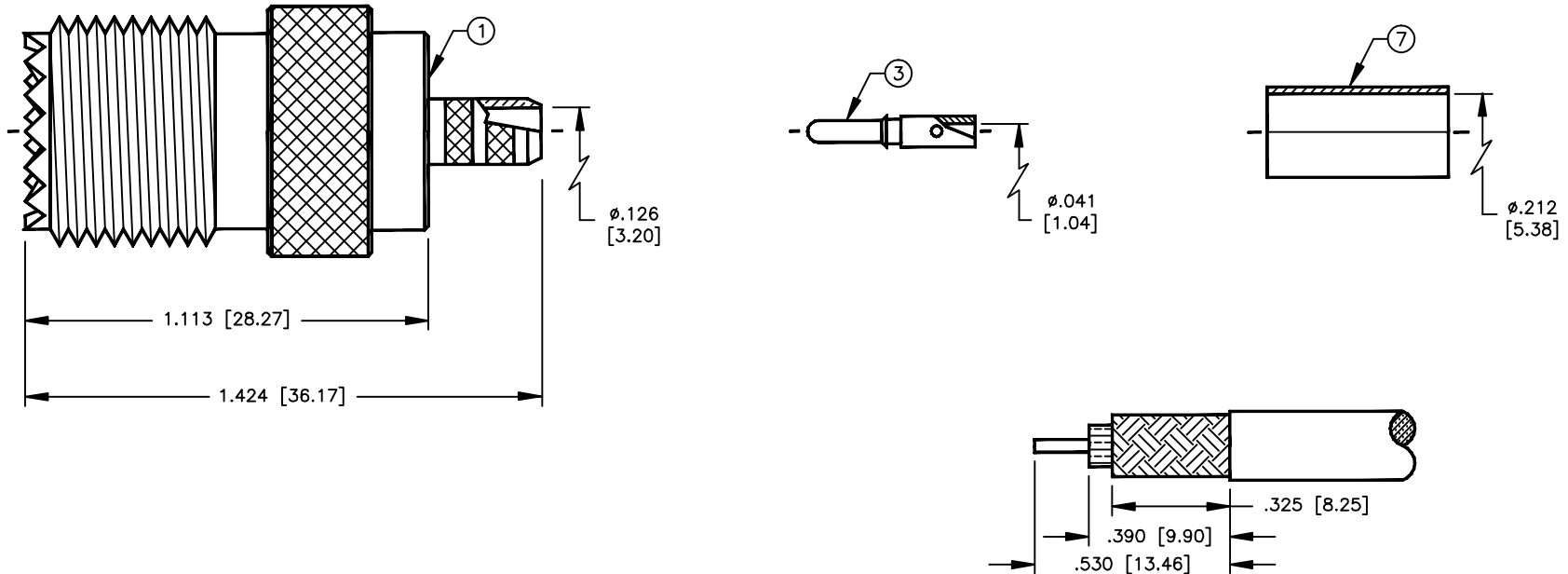

SUGGESTED STRIPPING INSTRUCTIONS

SUGGESTED CRIMP DIES: .068" & .213"

## SPECIFICATIONS:

IMPEDANCE: NON CONSTANT  
 WORKING VOLTAGE: 500 VRMS @ SEA LEVEL  
 FREQUENCY RANGE: 0-300 MHz  
 FOR RG-58, 58A, 58C, 141, 141A, BELDEN 8240,  
 8259, 8262, 9201, 9203, 9310, 9311 & COMM/SCOPE 0268

DIMENSIONS ARE IN INCHES AND [MILLIMETERS]

UNLESS OTHERWISE NOTED TOLERANCES ARE:  
 DECIMALS      DIAMETER

DRAWN C. ZUNIGA	12/8/99
CHECKED	
ORJ DRAWN W. DANIELS	1/19/94
APPROVALS	DATE

RF

connectors

7610 MIRAMAR RD  
 SAN DIEGO, CA 92126  
 (858) 549-6340  
 (858) 549-6345 FAX

DIVISION OF RF INDUSTRIES, LTD.

## RFU-527-T

UHF FEMALE CRIMP

ITEM	DESCRIPTION	QTY	MATERIAL	FINISH
7	CRIMP RING [FER-103]	1	BRASS	NICKEL
6	PRESS FIT WASHER	1	BRASS	NICKEL
5	DIELECTRIC	1	PTFE	NONE
4	DIELECTRIC	1	PTFE	NONE
3	REMOVABLE PIN	1	BRASS	SILVER
2	CONTACT	1	BRASS	SILVER
1	BODY	1	BRASS	NICKEL

SIZE A	CABLE GROUP C	DWG NO. 8294	REV D
SCALE: 2:1		CAD FILE 13ARC B	SHEET 1 OF 1