



User Manual

ACP-2000

**2U 19" Rackmount Industrial
Chassis for SHB/SBC**

Trusted ePlatform Services

ADVANTECH

Copyright

The documentation and the software included with this product are copyrighted 2009 by Advantech Co., Ltd. All rights are reserved. Advantech Co., Ltd. reserves the right to make improvements in the products described in this manual at any time without notice.

No part of this manual may be reproduced, copied, translated or transmitted in any form or by any means without the prior written permission of Advantech Co., Ltd. Information provided in this manual is intended to be accurate and reliable. However, Advantech Co., Ltd. assumes no responsibility for its use, nor for any infringements of the rights of third parties, which may result from its use.

Acknowledgements

The ACP-2000, PCE-7B06V, PCE-5B06V, PCE-5B05V, PCA-6106P3V and PCA-6105P4V are trademarks of Advantech Co., Ltd.

All other product names or trademarks are the properties of their respective owners.

On-line Technical Support

For technical support and service, please visit our support website at:
<http://www.advantech.com/support>

Safety Instructions

1. Read these safety instructions carefully.
2. Keep this user manual for later reference.
3. Disconnect this equipment from AC outlet before cleaning. Do not use liquid or spray detergents for cleaning.
4. For pluggable equipment, the power outlet shall be installed near the equipment and shall be easily accessible.
5. Keep this equipment away from humidity.
6. Put this equipment on a reliable surface during installation. Dropping it or letting it fall could cause damage.
7. The openings on the enclosure are for air convection hence protect the equipment from overheating. **DO NOT COVER THE OPENINGS.**
8. Make sure the voltage of the power source is correct before connecting the equipment to the power outlet.
9. Place the power cord in a way that people can not step on it. Do not place anything over the power cord. The voltage and current rating of the cord should be greater than the voltage and current rating marked on the product.
10. All cautions and warnings on the equipment should be noted.
11. If the equipment is not used for a long time, disconnect it from the power source to avoid being damaged by transient over-voltage.
12. Never pour any liquid into ventilation openings. This could cause fire or electrical shock.
13. Never open the equipment. For safety reasons, the equipment should be opened only by qualified service personnel.
14. If any of the following situations arises, get the equipment checked by service personnel:
 - The power cord or plug is damaged.
 - Liquid has penetrated into the equipment.
 - The equipment has been exposed to moisture.
 - The equipment does not work well or you cannot get it to work according to user manual.
 - The equipment has been dropped and damaged.
 - The equipment has obvious signs of breakage.
15. **DO NOT LEAVE THIS EQUIPMENT IN AN ENVIRONMENT WHERE THE STORAGE TEMPERATURE MAY GO BELOW -20°C (-4°F) OR ABOVE 60°C (140°F). THIS COULD DAMAGE THE EQUIPMENT. THE EQUIPMENT SHOULD BE IN A CONTROLLED ENVIRONMENT.**
16. **CAUTION: DANGER OF EXPLOSION IF BATTERY IS INCORRECTLY REPLACED. REPLACE ONLY WITH THE SAME OR EQUIVALENT TYPE RECOMMENDED BY THE MANUFACTURER, DISCARD USED BATTERIES ACCORDING TO THE MANUFACTURER'S INSTRUCTIONS.**
17. THE COMPUTER IS PROVIDED WITH CD DRIVES COMPLY WITH APPROPRIATE SAFETY STANDARDS INCLUDING IEC 60825.

CLASS 1 LASER PRODUCT KLASS 1 LASER PRODUKT
--

18. This device complies with Part 15 of the FCC rules. Operation is subject to the following two conditions:
 - (1) this device may not cause harmful interference, and
 - (2) this device must accept any interference received, including interference that may cause undesired operation.
19. **CAUTION:** Always completely disconnect the power cord from your chassis whenever you work with the hardware. Do not make connections while the power is on. Sensitive electronic components can be damaged by sudden power surges.
20. **CAUTION:** Always ground yourself to remove any static charge before touching the motherboard, backplane, or add-on cards. Modern electronic devices are very sensitive to static electric charges. As a safety precaution, use a grounding wrist strap at all times. Place all electronic components on a static-dissipative surface or in a static-shielded bag when they are not in the chassis.
21. **CAUTION:** Any unverified component could cause unexpected damage. To ensure the correct installation, please always use the components (ex. screws) provided with the accessory box.

A Message to the Customer

Advantech customer services

Each and every Advantech product is built to the most exacting specifications to ensure reliable performance in the harsh and demanding conditions typical of industrial environments. Whether your new Advantech equipment is destined for the laboratory or the factory floor, you can be assured that your product will provide the reliability and ease of operation for which the name Advantech has come to be known. Your satisfaction is our primary concern. Here is a guide to Advantech's customer services.

To ensure you get the full benefit of our services, please follow the instructions below carefully.

Technical support

We want you to get the best performance possible from your products. If you run into technical difficulties, we are here to help. For the most frequently asked questions, you can easily find answers in your product documentation. These answers are normally a lot more detailed than the ones we can give over the phone.

Please consult this manual first. If you still cannot find the answer, gather all the information or questions that apply to your problem, and with the product close at hand, call your dealer. Our dealers are well trained and ready to give you the support you need to get the most from your Advantech products. In fact, most problems reported are minor and can be easily solved over the phone.

In addition, free technical support is available from Advantech engineers every business day. We are always ready to give advice about application requirements or specific information on the installation and operation of any of our products.

Product Warranty (2 years)

Advantech warrants to you, the original purchaser, that each of its products will be free from defects in materials and workmanship for two years from the date of purchase.

This warranty does not apply to any products which have been repaired or altered by persons other than repair personnel authorized by Advantech, or which have been subject to misuse, abuse, accident or improper installation. Advantech assumes no liability under the terms of this warranty as a consequence of such events.

Because of Advantech's high quality-control standards and rigorous testing, most of our customers never need to use our repair service. If an Advantech product is defective, it will be repaired or replaced at no charge during the warranty period. For out-of-warranty repairs, you will be billed according to the cost of replacement materials, service time and freight. Please consult your dealer for more details.

If you think you have a defective product, follow these steps:

1. Collect all the information about the problem encountered. (For example, CPU speed, Advantech products used, other hardware and software used, etc.) Note anything abnormal and list any onscreen messages you get when the problem occurs.
2. Call your dealer and describe the problem. Please have your manual, product, and any helpful information readily available.
3. If your product is diagnosed as defective, obtain an RMA (return merchandise authorization) number from your dealer. This allows us to process your return more quickly.
4. Carefully pack the defective product, a fully-completed Repair and Replacement Order Card and a photocopy proof of purchase date (such as your sales receipt) in a shippable container. A product returned without proof of the purchase date is not eligible for warranty service.
5. Write the RMA number visibly on the outside of the package and ship it prepaid to your dealer.

Initial Inspection

When you open the carton, please make sure that the following materials have been shipped:

- ACP-2000 Chassis
- User Manual
- Warranty Card
- Accessory package with screws (for fastening the backplane, disk drives and ears, etc.), a pair of keys, a spare filter and a pair of ears and handles.

If any of these items are missing or damaged, contact your distributor or sales representative immediately. We have carefully inspected the ACP-2000 mechanically and electrically before shipment. It should be free of marks and scratches and in perfect working order upon receipt. As you unpack the ACP-2000, check it for signs of shipping damage. (For examples: box damage, scratches, dents, etc.) If it is damaged or it fails to meet the specifications, notify our service department or your local sales representative immediately. Also, please notify the carrier. Retain the shipping carton and packing material for inspection by the carrier. After inspection, we will make arrangements to repair or replace the unit.

Contents

Chapter 1	General Information	1
1.1	Introduction	2
1.2	Specifications	2
1.3	Power Supply Options.....	3
	Table 1.1: Power supply options	3
1.4	Environmental Specifications.....	3
1.5	Dimension Diagram.....	4
	Figure 1.1 Dimension diagram.....	4
Chapter 2	System Setup	5
2.1	Removing the Top Cover	6
	Figure 2.1 Removing the top cover.....	6
2.2	Installing the Backplane	6
	Figure 2.2 Installing the backplane	7
2.3	Installing CPU Cards and Add-on Cards.....	7
	Figure 2.3 Installing a CPU card.....	7
	Figure 2.4 Installing the add-on card	8
2.4	Installing Disk Drives.....	8
	Figure 2.5 Exploded diagram of the drive housing	8
	Figure 2.6 Installing the disk drives	9
2.5	Attaching the Ears and Handles.....	9
Chapter 3	Operation.....	11
3.1	Front and Rear Sections of the Chassis	12
	Figure 3.1 Switch and buttons	12
	Figure 3.2 Front view with door closed	12
	Figure 3.3 Front view with door open	12
3.1.1	Switch, Button and I/O Interfaces	13
	Figure 3.4 Rear view.....	13
3.2	System Status Indicators	13
	Table 3.1: LED indications function	13
3.3	Replacing the Cooling Fan & Filter	14
	Figure 3.5 Replacing the filter.....	14
3.4	Replacing the Power Supply	14
	Figure 3.6 Replacing the redundant power module.....	14
Chapter 4	Alarm Board	15
4.1	Alarm Board Layout	16
	Figure 4.1 Alarm board layout	16
4.2	Alarm Board Specifications	17
4.2.1	Connectors & Pin Definition	17
	Table 4.1: CN1, Auxiliary external power connector, standard mini 4-Pin power connector.....	17
	Table 4.2: CN4, Thermal sensor (LM75) connector	17
	Table 4.3: CN13, Voltage detect. input connector.....	17
	Table 4.4: CN16, Power good input connector.....	17
	Table 4.5: CN17, Alarm reset connector	17
	Table 4.6: CN18, Output connector to LED board.....	18
	Table 4.7: CN26, HDD LED connector.....	18

	Table 4.8: FAN1~FAN7, Fan connectors	18
	Table 4.9: J1, External buzzer.....	18
	Table 4.10: SW1, Fan number select switch.....	18
4.2.2	Switch Settings	19
	Table 4.11: SW1, Fan number setting.....	19
4.3	Thermal Sensor	20
	Figure 4.2 Thermal sensor location	20
	Figure 4.3 Thermal sensor module.....	20
	Table 4.12: CN1 & CN2, Temperature sensor connector	21
	Table 4.13: SW1, Thermal sensor I.D. setting	21

Appendix A **Exploded Diagram 23**

A.1	Exploded Diagram	24
	Figure A.1 Exploded diagram	24

Appendix B **Backplane Options 25**

B.1	Backplane Options.....	26
	Table B.1: PICMG 1.3 Backplane Options	26
	Table B.2: PICMG 1.0 Backplane Options	26

Chapter 1

General Information

This chapter provides general information about the ACP- 2000.

Sections include:

- Introduction
- Specifications
- Power Supply Options
- Environment Specifications
- Dimension Diagram

1.1 Introduction

ACP-2000 is a compact yet rugged 2U 19" rackmount IPC chassis designed for space-conscious applications. Customers can expand their businesses without having to worry about space efficiency because the APC-2000 is only 2U in height and satisfies requirements for CT, voice portal, high-density voice processing, networking and industrial automation applications. Fast-growing Internet service providers and corporate enterprise customers can use the ACP-2000 as an e-server platform for their internet/intranet, proxy, caching, access, DNS, or file and print server. The ultra-thin 2U form factor delivers rack space optimization without sacrificing performance, expandability, serviceability, or manageability

1.2 Specifications

General

- **Construction:** Heavy-duty steel
- **Disk Drive Capacity:** One slim-type ODD and two 3.5" disk drives
- **Cooling System:** Dual easy-to-maintain 47 CFM cooling fan with air filter
- **Air Filters:** Two easily maintained reusable filters near the front of the system fan and behind the front door.
- **Controls:** Power switch, system reset button and alarm reset button behind the lockable door
- **Indicators:**
 - **Power:** Bi-color LED (green/red) for power failure
 - **HDD:** Single-color LED (orange) for HDD activity
 - **Fan:** Bi-color LED (green/red) for any fan failure
 - **Temperature:** Bi-color LED (green/red)
- **Weight:** 11.5 kg (25.3 lb)
- **Dimensions (W x H x D):** 482 x 88 x 452 mm (19" x 3.5" x 17.8")
- **Chassis Color:** Black (Pantone 4C2X)

1.3 Power Supply Options

Table 1.1: Power supply options

Model Name	Watts	Input rating	Output voltage	Minimum load	Safety	MTBF
PS-310-DC48E (ATX)	300 W	DC -48 V	+3.3 V @ 28 A +5 V @ 30 A +12 V @ 15 A -5 V @ 0.3 A -12 V @ 0.8 A +5 Vsb @ 2 A	+5 V @ 0.3 A +3.3 V @ 0.3 A +12 V @ 0.2 A	UL/TUV/ CB/CCC	100,000 hours
PS-300ATX-ZBE (ATX,PFC)	300 W	AC 100 ~ 240 Vac (full range)	+5 V @ 30 A +3.3 V @ 28A +12 V @ 15 A -12 V @ 0.8 A -5 V @ 0.3 A +5 Vsb @ 2 A	+5 V @ 1 A +12 V @ 0.5 A +3.3 V @ 0.3 A	UL/TUV/ CB/CCC	100,000 hours@ 25°C
RPS-300ATX-ZBE (ATX PFC)	300 W	AC 100 ~ 240 Vac (full range)	+5 V @ 30 A +3.3 V @ 28 A +12 V @ 15 A -12 V @ 0.8 A -5 V @ 0.3 A +5 Vsb @ 2 A	+5 V @ 0.5 A +12 V @ 0.5 A	UL/TUV/ CB/CCC	100,000 hours@ 25°C

1.4 Environmental Specifications

- **Operating temperature:** 0°C ~ +40°C (32°F ~ 104°F)
- **Storage temperature:** -40°C ~ +75°C (-40°F ~ +167°F)
- **Relative Humidity:** 10 ~ 95% @ 40°C, non-condensing
- **Vibration:** (Operating) 5Hz ~ 500Hz, 1G rams
- **Random Vibration:** (Non-operation) 5 ~ 20 Hz, 0.001 ~ 0.01 G²/Hz, 20 ~ 500 Hz, 0.01 G²/Hz
- **Shock (operating):** 2.0 G with 11m Sec duration, 1/2 sine wave

1.5 Dimension Diagram

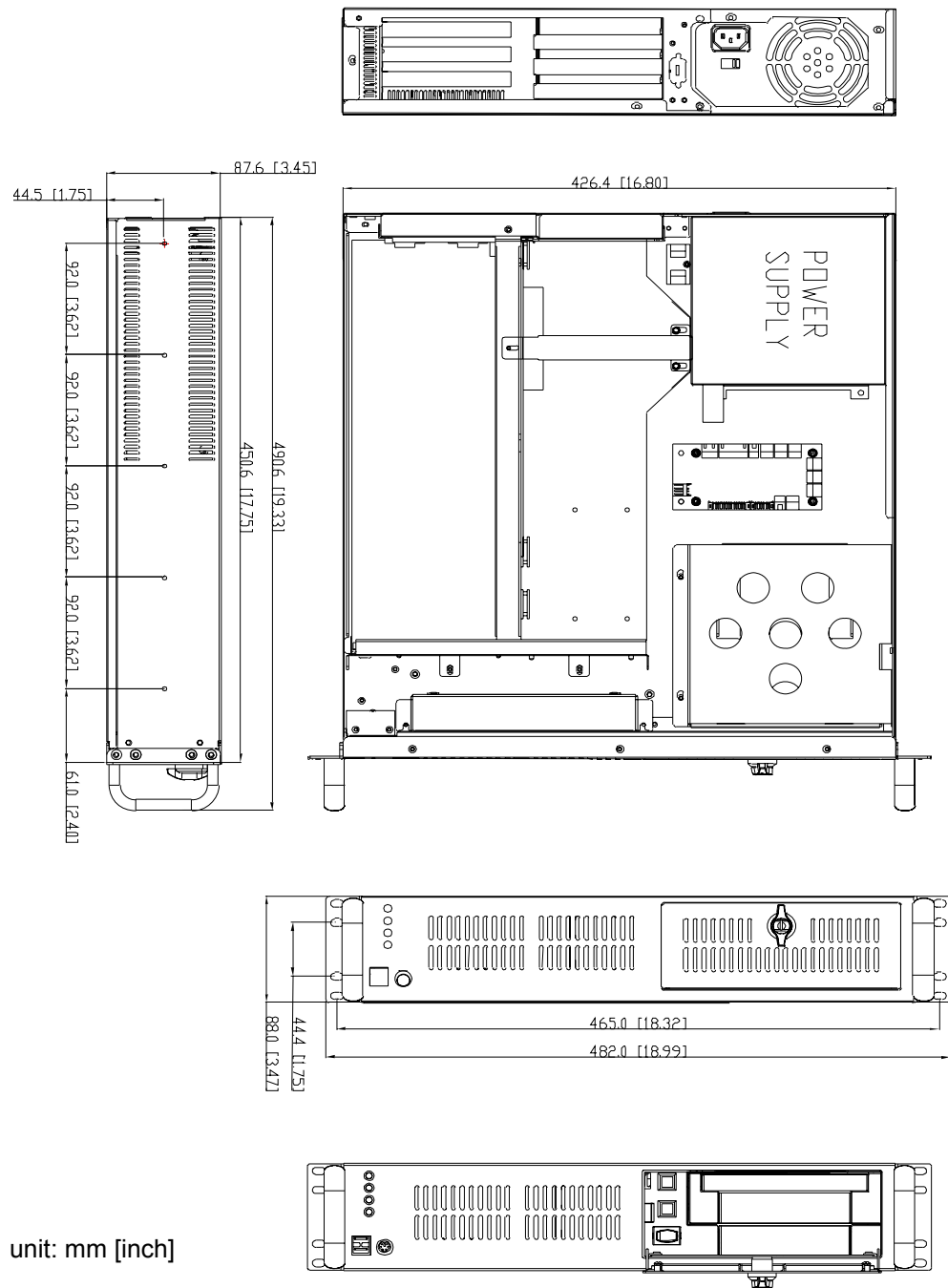

Figure 1.1 Dimension diagram

Chapter 2

System Setup

This chapter introduces the installation process.

Sections include:

- Installing the Backplane
- Installing a CPU Card and Add-on Cards
- Installing Disk Drives
- Installing Ears & Handles

The following procedures instruct users on how to install the backplane, CPU card, add-on cards, and the disk drives into the chassis. Please refer to the Appendix A, Exploded diagram, for all the detailed part names.

Note! *Use caution when installing or operating the components with the chassis open. Be sure to turn off the power, unplug the power cord and ground yourself by touching the metal chassis before you handle any components inside the machine.*



2.1 Removing the Top Cover

The first installation step is removing the chassis cover. You will need a Phillips screwdriver.

The top cover is fixed to the chassis with six screws.

To remove the top covers:

1. Detach the six screws on the chassis.
2. Lift off the cover.



Figure 2.1 Removing the top cover

2.2 Installing the Backplane

ACP-2000P3 and the ACP-2000P4 come with the backplane. The ACP-2000EBP allows users to choose the proper PICMG 1.3 express backplane.

To install the motherboard, please proceed as follows:

Note! *Use caution when installing a motherboard. We highly recommend choosing a CPU cooler which is lower than 67 mm to avoid component interference between the motherboard and the chassis, and to ensure good air flow inside the chassis.*



1. Remove the card holder by loosening the two screws.
2. Attach the motherboard I/O shielding onto the rear plate first. Then fasten the motherboard onto the chassis.
3. Return the card holder to its original position and fasten it.
4. Connect the 20-pin (or 24-pin) ATX power connector and the 4-pin +12 V power connector from the power supply to the motherboard.
5. Connect the 9-pin USB wire, PS/2 wire, Power switch wire, and the System Reset switch wire from the chassis to the motherboard.

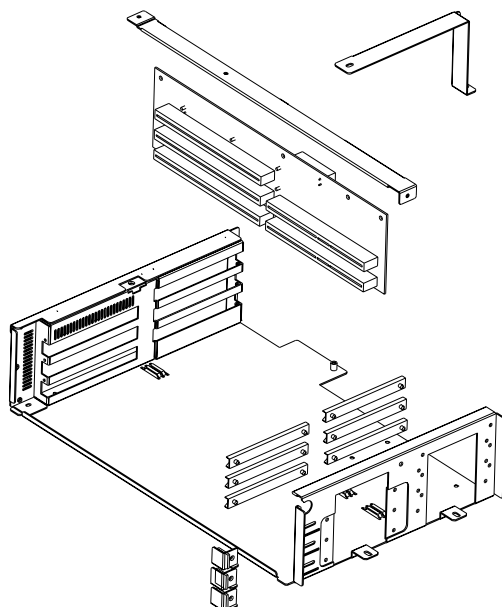

Figure 2.2 Installing the backplane

2.3 Installing CPU Cards and Add-on Cards

To install a CPU card and other add-on boards, please follow below steps.

1. Remove the chassis cover.
2. Loosen the backplane holder and take it out.
3. Insert the CPU card from the left-side, or add-on card from the right-side, into the vacant slot.
4. Align and fix the screw to tighten the card to a fixed position, refer to Figure 2.3 and Figure 2.4.
5. Return the backplane holder, with the backplane, CPU card or add-on cards to the chassis.

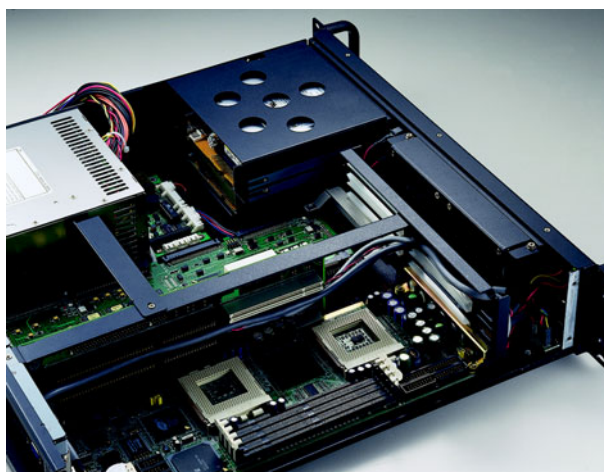

Figure 2.3 Installing a CPU card

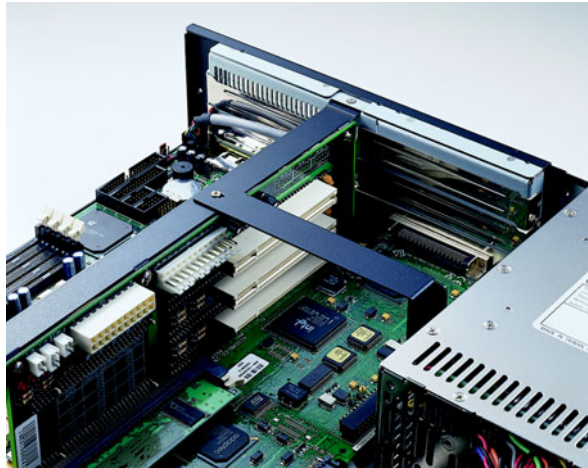

Figure 2.4 Installing the add-on card

2.4 Installing Disk Drives

The ACP-2000 can hold one slim-type ODD, and two 3.5" disk drives (one internal and one external). Please follow the steps below to install the disk drives.

1. Remove the top cover
2. Remove the drive housing by loosening the 6 screws.
3. Insert the drives into their proper locations in the drive housing, and secure with the provided screws.
4. Connect the power wires and the signal cables to the disk drives.

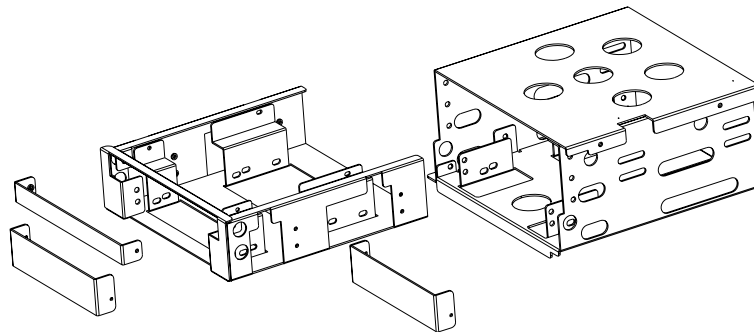

Figure 2.5 Exploded diagram of the drive housing

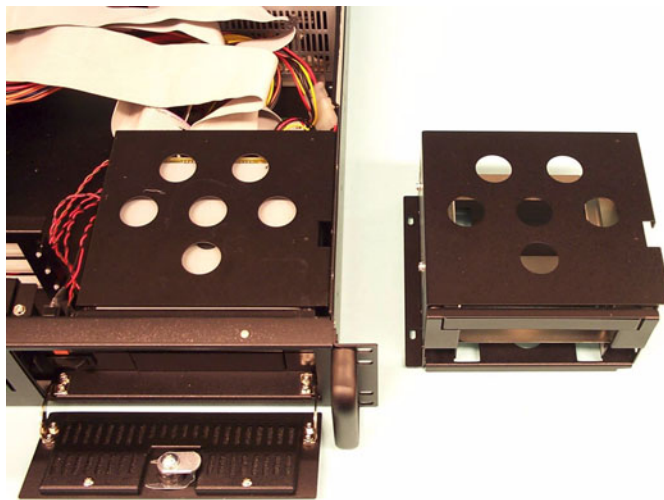

Figure 2.6 Installing the disk drives

2.5 Attaching the Ears and Handles.

There is a pair of ears and a pair of handles in the accessory box. Simply fasten them to the front-right and front-left edges with the screws provided.

Chapter 3

Operation

This chapter introduces the system operating information.

Sections include:

- The Front Panel
- The Rear Panel
- Replacing the Cooling Fan
- Replacing the Filter
- Replacing the Power Supply

3.1 Front and Rear Sections of the Chassis

The front panel switches located behind the door are used for system power, system reset and alarm reset. On the left side of front panel, there are system LED status, USB and P/S 2 keyboard connector. On the left side of the front panel is the door cover with a key lock.

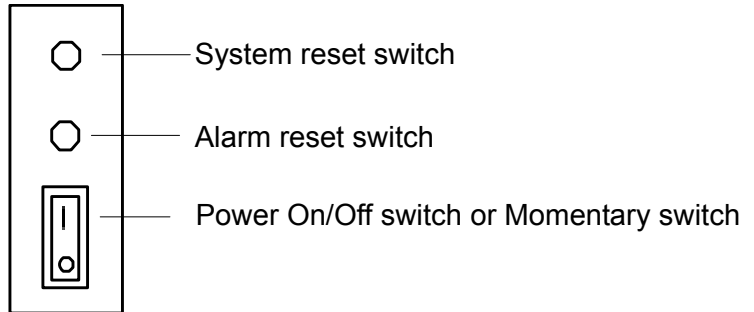

Figure 3.1 Switch and buttons



Figure 3.2 Front view with door closed



Figure 3.3 Front view with door open

3.1.1 Switch, Button and I/O Interfaces

- **Momentary Power switch:** Using the ATX (PS_ON) function, turn on the system power.
- **System Reset button:** Press this switch to reinitialize the system, which is the same as the hardware reset button.
- **Alarm Reset button:** Press this switch to pause or stop an audible alarm. Whenever a fault in the system occurs (e.g. fan failure, rising chassis temperature, backplane voltage problem), an audible alarm is activated. Pressing this switch will cause the alarm to stop.
- **USB connector:** Used in connecting USB interface device to the system.
- **PS/2 connector:** Used in connecting PS/2 keyboard.

The Rear Section includes: 6-slot I/O bracket, a 9-pin D-SUB pre-punched opening and PS/2 power supply



Figure 3.4 Rear view

3.2 System Status Indicators

The System Status LED shows as follows:

Table 3.1: LED indications function

LED	Description	RED	GREEN or Orange
POWER	System power	Abnormal	Normal
HDD	Hard Drive activity	No light	Data access
TEMP	Temperature in the chassis	Abnormal	Normal
FAN	Cooling fan status	Abnormal	Normal

When the POWER LED is RED, it indicates a failure of one redundant power supply. To stop the alarm buzzer, press the Alarm Reset button. Please check the redundant power supply right away, and replace failed power supply module with a good one.

When the FAN LED is RED and blinking, it indicates a failing cooling fan. An alarm is also activated. To stop the alarm buzzer, press the Alarm Reset button then replace the fan immediately.

If the TEMP LED is RED and blinking, the system detects rising temperature inside the chassis. An alarm is activated. To stop the alarm buzzer, press the Alarm Reset button. Inspect the rear section and fan filter immediately. Make sure airflow inside the chassis is smooth and not blocked with dust or other particles.

3.3 Replacing the Cooling Fan & Filter

There are two cooling fans located near the front left of the chassis. They are easy to maintain and provide adequate cooling to the system by blowing cool air inward. When one cooling fan breaks down, the system sounds a continuous alarm. Please push the alarm reset button to stop the beep and replace the failing fan immediately.

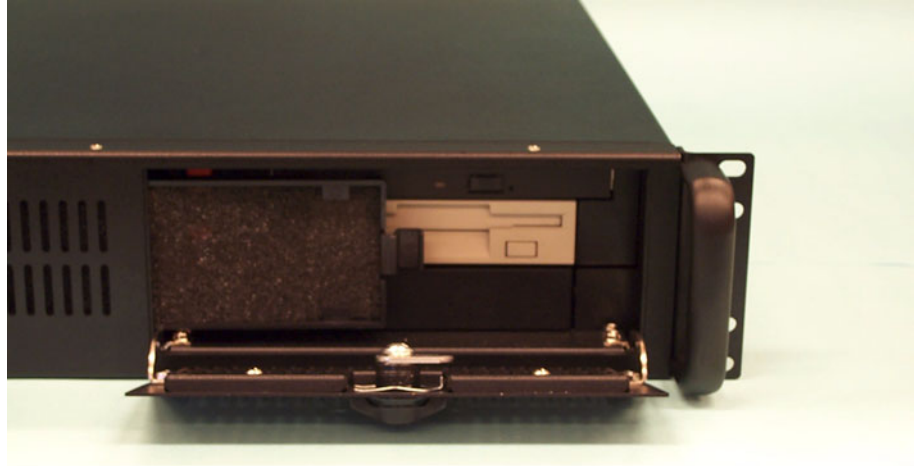

Figure 3.5 Replacing the filter

3.4 Replacing the Power Supply

The ACP-2000 supports PS/2 single or redundant power supply.



Figure 3.6 Replacing the redundant power module

Chapter 4

Alarm Board

This chapter introduces the alarm board and thermal sensor specifications.

Sections include:

- Alarm Board Layout
- Alarm Board Specifications
- Thermal Sensor
- Sensor I.D. Number Setting

The alarm board is located under the 3.5" disk drive bay. The alarm board provides system detection functions that monitor the entire status of the computer system, including: thermal conditions, fans, power supply and HDD operation. Any problems with the system are reported through audible alarms and LED indicators.

The alarm board sounds an audible alarm whenever:

1. Any power supply module of the redundant power supply fails;
2. One of the system cooling fans fails;
3. The internal temperature of the chassis becomes too high.

To stop the alarm beep, press the Alarm Reset button on the front panel and then take the necessary action to fix it.

4.1 Alarm Board Layout

The layout and detailed specifications for connectors on the alarm board are shown in this diagram:

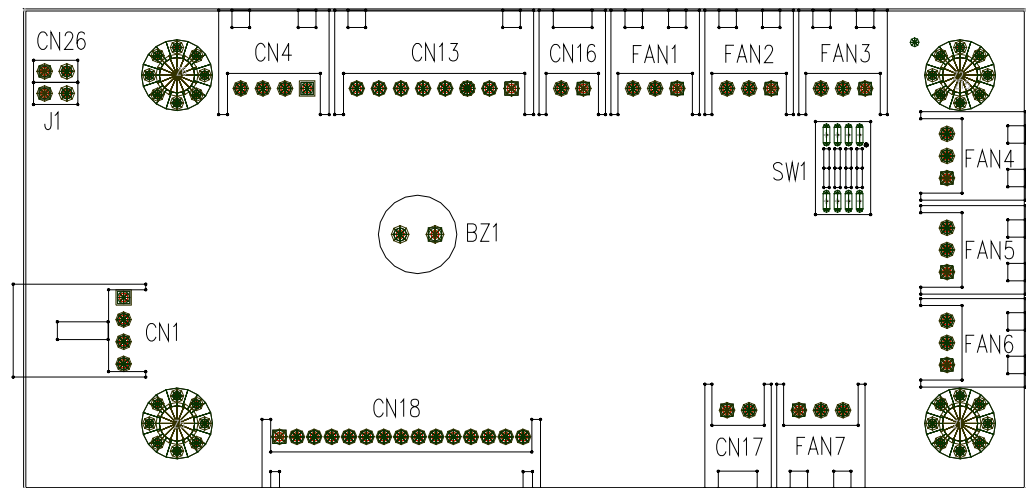

Figure 4.1 Alarm board layout

4.2 Alarm Board Specifications

- **Input Power:** +5 V, +12 V
- **Input Signals:**
 - 7 "fan" connectors
 - One "thermal sensor" connector (supports up to 8 thermal sensors connected in a series)
 - One "power good" input
 - One "alarm reset" input
 - One "voltage signal" connector (connected from the motherboard, and supports six voltages: +- 12 V, +- 5 V, +3.3 V, +5 Vsb)
 - One "hard disk LED" connector (connected from the motherboard)
- **Output Signals:**
 - One "LED board" connector
 - One "buzzer" output

4.2.1 Connectors & Pin Definition

Table 4.1: CN1, Auxiliary external power connector, standard mini 4-Pin power connector

Pin 1	+12 V	Pin 3	GND
Pin 2	GND	Pin 4	+5 V

Table 4.2: CN4, Thermal sensor (LM75) connector

Pin 1	+5 V	Pin 3	T_SDAT
Pin 2	T_SCLK	Pin 4	GND

Table 4.3: CN13, Voltage detect. input connector

Pin 1	+5 Vsb	Pin 5	+5 V
Pin 2	GND	Pin 6	+3.3 V
Pin 3	GND	Pin 7	-12 V
Pin 4	-5 V	Pin 8	+12 V

Table 4.4: CN16, Power good input connector

Pin 1	Power Good	Pin 2	GND
--------------	------------	--------------	-----

Table 4.5: CN17, Alarm reset connector

Pin 1	ALARM RESET	Pin 2	GND
--------------	-------------	--------------	-----

Table 4.6: CN18, Output connector to LED board

Pin 1	GND	Pin 9	Temperature Good
Pin 2	+5 V signal	Pin 10	Temperature Fail
Pin 3	+12 V signal	Pin 11	FAN Good
Pin 4	-5 V signal	Pin 12	FAN Fail
Pin 5	-12 V signal	Pin 13	N/A
Pin 6	HDD_1	Pin 14	+3.3 V signal
Pin 7	Power Good	Pin 15	+5 Vsb signal
Pin 8	Power Fail		

Table 4.7: CN26, HDD LED connector

Pin 1	HLED_ACT	Pin 2	N/A
--------------	----------	--------------	-----

Table 4.8: FAN1~FAN7, Fan connectors

Pin 1	GND	Pin3	FAN_DEC
Pin 2	+12 V		

Table 4.9: J1, External buzzer

Pin 1	Buzzer	Pin 2	+5 V
--------------	--------	--------------	------

Table 4.10: SW1, Fan number select switch

Pin 1	GND	Pin 5	GND
Pin 2	FAN_SEL1	Pin 6	FAN_SEL3
Pin 3	GND	Pin 7	GND
Pin 4	FAN_SEL2	Pin 8	RESET

4.2.2 Switch Settings

The alarm board is designed to connect with up to 7 fans. Users can set the fan number by adjusting the switch, SW1, on the alarm board.

Table 4.11: SW1, Fan number setting

Fan Number	SW 1-1	SW 1-2	SW 1-3	SW 1-4
0	OFF	OFF	OFF	OFF
1	ON	OFF	OFF	OFF
2 (default)	OFF	ON	OFF	OFF
3	ON	ON	OFF	OFF
4	OFF	OFF	ON	OFF
5	ON	OFF	ON	OFF
6	OFF	ON	ON	OFF
7	ON	ON	ON	OFF

Note!  Connect the fan connectors in the correct sequence: if two fans are set on SW1, the correct method is to connect them to connectors FAN1 and FAN2. If the two fans are connected to other fan connectors, out of sequence, such as FAN1 and FAN3 or FAN2 and FAN3 or FAN3 and FAN4, instead of FAN1 and FAN2, then the alarm will not function correctly.

4.3 Thermal Sensor

The ACP-2000 is configured with a thermal sensor on the backside of the chassis (see Figure 4.2).

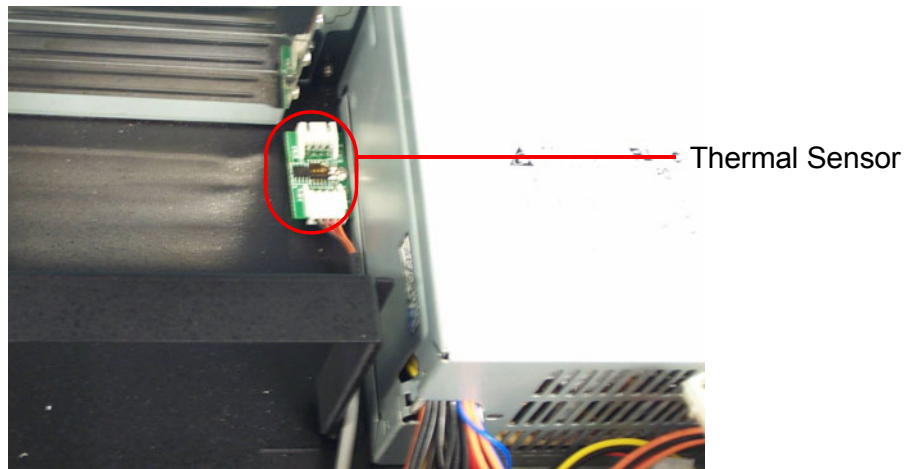

Figure 4.2 Thermal sensor location

Refer to Figure 4.3 for a diagram of the thermal sensor module layout.

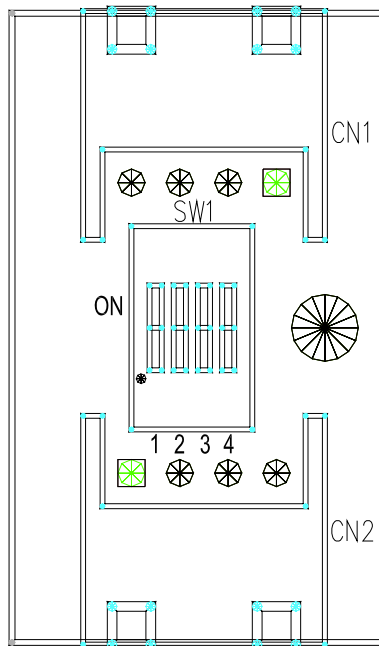

Figure 4.3 Thermal sensor module

The default sensor I.D. number is 1. Users can refer to Table 4.13 to set the sensor I.D. number by adjusting the switch, SW1, on the sensor module.

Table 4.12: CN1 & CN2, Temperature sensor connector

Pin 1	+5 V	Pin 3	T_SDAT
Pin 2	T_SCLK	Pin 4	GND

Table 4.13: SW1, Thermal sensor I.D. setting

Sensor I.D. No.	SW 1-1	SW 1-2	SW 1-3	SW 1-4
1 (default)	OFF	OFF	OFF	ON
2	OFF	OFF	ON	ON
3	OFF	ON	OFF	ON
4	OFF	ON	ON	ON
5	ON	OFF	OFF	ON
6	ON	OFF	ON	ON
7	ON	ON	OFF	ON
8	ON	ON	ON	ON

Appendix **A**

Exploded Diagram

A.1 Exploded Diagram

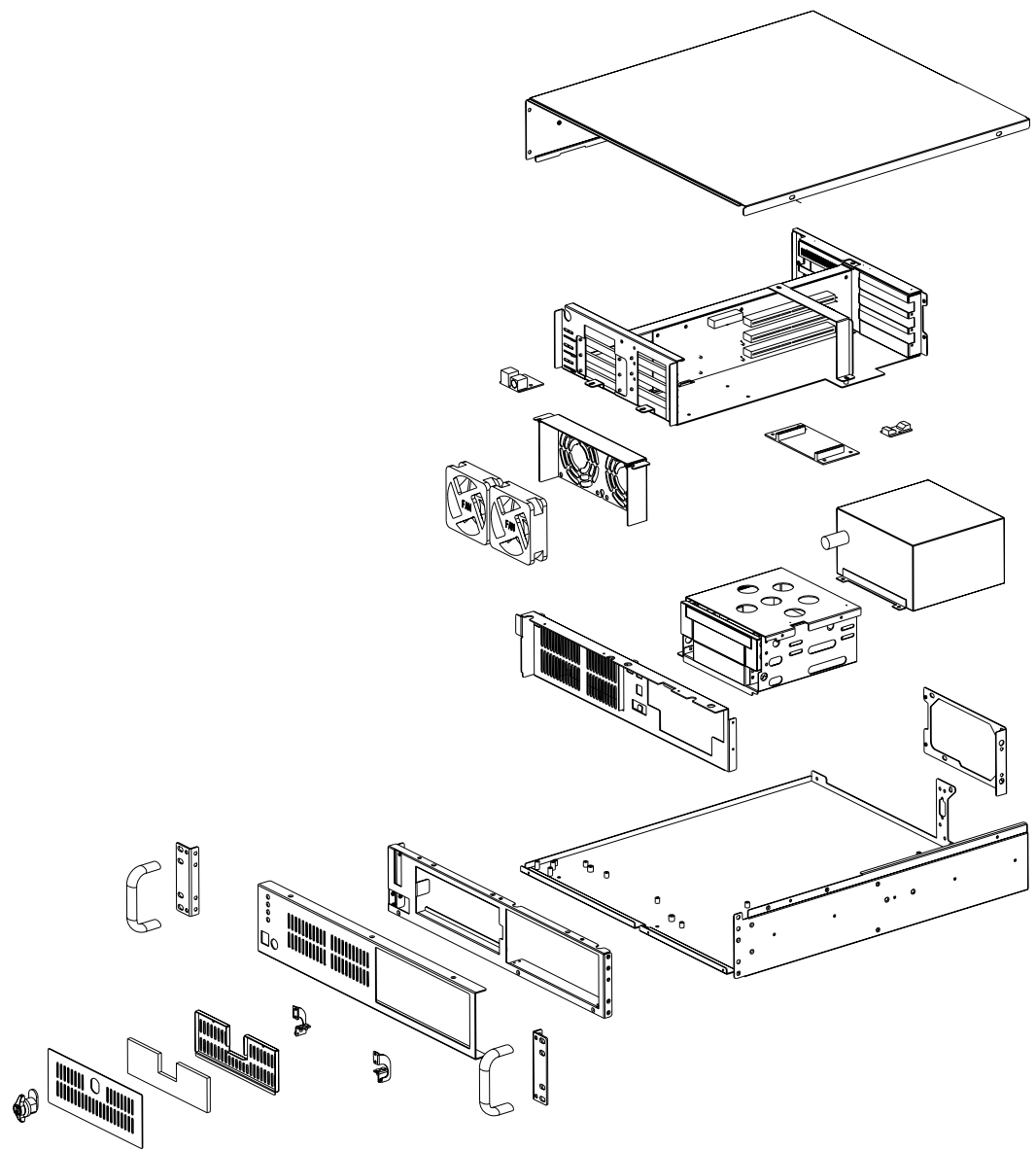

Figure A.1 Exploded diagram

Appendix **B**

Backplane Options

B.1 Backplane Options

ACP-2000 supports the following backplanes. User can contact a local sales representative for detailed specification and information.

Table B.1: PICMG 1.3 Backplane Options

Model Name	Slot			
	PICMG	PCI	PCIe	PCI-X
PCE-5B06V	1	4 (32-bit)	1 x 16	-
PCE-5B05V	1	-	1 x 16	2 (64-bit/100 MHz) 1 (64-bit/133 MHz)

Table B.2: PICMG 1.0 Backplane Options

Model Name	Slot	
	PICMG	PCI
PCA-6103P2V	1	2 (32-bit)
PCA-6103P2VX	1	2 (64-bit)

Trusted ePlatform Services

ADVANTECH

www.advantech.com

Please verify specifications before quoting. This guide is intended for reference purposes only.

All product specifications are subject to change without notice.

No part of this publication may be reproduced in any form or by any means, electronic, photocopying, recording or otherwise, without prior written permission of the publisher.

All brand and product names are trademarks or registered trademarks of their respective companies.

© Advantech Co., Ltd. 2009