

Absence of Voltage Tester Instruction Manual

Models: VS-AVT-C02-L03, VS-AVT-C02-L03A, VS-AVT-C02-L03E, VS-AVT-C02-L10,
VS-AVT-C08-L10, VS-AVT-C08-L10A, VS-AVT-C08-L10E

© Panduit Corp. 2018

Original Instructions



The VeriSafe Absence of Voltage Tester is a permanently-mounted tester that is used to verify a circuit is de-energized prior to opening an electrical enclosure. Once installed, a push of a button enables qualified electrical workers to verify the absence of voltage and see an active indication when the absence of voltage is confirmed. The Indicator Module is designed for a 30-mm notched panel knockout and the Isolation Module can be mounted to DIN rail or surface mounted using screws.



TO REDUCE THE RISK OF INJURY, USER MUST READ INSTRUCTION MANUAL



NOTE: In the interest of higher quality and value, Panduit products are continually being improved and updated. Consequently, pictures may vary from the enclosed product.

NOTE: Updates to this Instruction Manual may be available. Check www.panduit.com for the latest version of this manual.

North America Tech Support:
techsupport@panduit.com
Tel: 1-866-405-6654

EU Tech Support :
techsupportemea@panduit.com
Tel: +31-546-580-452
Fax: +31-546-580-441

PANDUIT
www.panduit.com

Asia Pacific Tech Support:
TechSupportAP@panduit.com

Telephone:
Singapore: 1-800-Panduit (7263848)
Australia: 1-800-Panduit (7263848)
Korea: 02-21827300

Table of Contents

Safety Information..... 2

Information de Sécurité 3

Components 4

Output Contacts 4

Technical Specifications..... 5

Dimensions 7

Schematics 8

Schematics - EU10

Installation Considerations13

Installation Instructions.....15

Commissioning Checklist:17

Operating Instructions18

Troubleshooting19

Maintenance20

 Battery Replacement.....20

 AVT System Cable Removal21

 O-ring Replacement21

 Cleaning Instructions.....21

 Visual Inspection21

Warranty22

Safety Information

This manual contains information and warnings which must be followed to ensure safe operation of the AVT. If the AVT is not used as described in this manual, the safety features of the AVT might be impaired. **Failure to comply with the warnings and information in this manual could result in product failure, electrical shock, severe injury or death.**



Warning:



- Always de-energize power before accessing an electrical enclosure.
- Always follow safety and lockout/tagout procedures when working on or near electrical systems and equipment.
- Use of the AVT does not replace lockout/tagout procedures. The AVT is intended to be used in conjunction with lockout/tagout processes and only addresses the absence of voltage verification step.
- Use proper personal protective equipment (PPE) when working around sources of hazardous electrical energy.
- Do not use this product outside of the specified performance and environmental limits.
- This product must be installed by a qualified electrical worker familiar with local and national electrical codes.
- The AVT will only test for absence of voltage at the point in the circuit where it is installed. If there are other sources of power in the equipment, dangerous voltage may be present.
- Absence of voltage is indicated by illumination of the green Absence of Voltage Indicator. Absence of voltage is not guaranteed when the red Voltage Presence Indicators are not illuminated.
- The AVT must be installed correctly and grounded as described in this Instruction Manual to provide proper indication of absence of voltage. Sensor leads must not be mechanically connected with each other for the device to verify connection to the circuit. Correct function of the device must be verified after installation (see commissioning checklist).
- Sensor leads of the same color should be terminated on the same conductor. Each conductor should have at least one sensor lead set, as shown on the schematic diagrams.
- Excess length from Sensor Leads should be trimmed; Sensor Leads should not be extended with a splice.
- Always comply with local installation codes and standards.
- The AVT will not work with a standard alkaline 1.5Volt AA battery. Use only approved batteries listed in table shown in the Maintenance section of this instruction manual.
- The product uses a lithium battery that is a fire, explosion and severe burn hazard. Do not crush, recharge, disassemble or heat above 85°C, incinerate, or expose contents to water.
- Use only the included AVT System Cable or approved replacement cables to connect the Isolation Module and Indicator Module. Do not use a standard Ethernet cable.
- Battery, AVT System Cable and O-rings can be replaced. No other part of the product is serviceable. Do not attempt to open the Indicator Module or Isolation Module for repair or modification. When servicing this product, only use specified replacement parts.
- The section of the Indicator Module that is external to the electrical enclosure is approved for wash down when installed in an appropriate enclosure. Before a wash down operation, ensure the o-rings are in good condition, the faceplate is undamaged and fully secured to the unit and the cap is fully installed.
- The AVT System Cable must be separated from the sensor leads and other circuits in the electrical enclosure by a minimum of 0.25 inches (6 mm).
- To prevent damage to the AVT in high-vibration installations, surface mount the Isolation Module using screws and secure the Sensor Lead Wires and AVT System Cable to prevent strain on the connection points.
- If a Sensor Lead separates from the termination point to the power conductor and contacts a low impedance path to ground, the connectivity test can be defeated resulting in a false absence of voltage indication. Ensure that all sensor leads are terminated properly and secured to the power conductor or other nearby rigid feature to prevent movement if the termination fails to remain intact.

Should a problem occur during installation, operation or maintenance of the VeriSafe AVT, contact Panduit using one of the technical support or customer service numbers listed on the cover of this manual. Contact Panduit if you have any product problems related to the safety function of the product. The product model number and serial number are printed on the Isolation Module and Indicator Module labels.



VeriSafe is a product containing electronic circuit boards in both the Indicator and Isolation Modules. The Indicator Module contains a lithium battery. When decommissioning, remove the battery. Do not discard the battery in the trash; take it to an appropriate battery recycling facility. The Indicator and Isolation Modules can be disposed of at an electronics recycling facility.

Information de Sécurité

Ce manuel contient des informations et des avertissements qui doivent être suivis pour assurer un fonctionnement en toute sécurité de l'AVT. Si l'AVT n'est pas utilisé comme décrit dans ce manuel, les fonctions de sécurité de l'AVT pourraient être altérées. **Le non-respect des avertissements et des informations contenus dans ce manuel pourrait entraîner une défaillance du produit, des chocs électriques, des blessures graves ou la mort.**



Attention:



- *Toujours éteindre l'alimentation électrique avant d'accéder à un boîtier électrique.*
- *Suivez toujours les procédures de sécurité et de verrouillage/étiquetage (lockout/tagout) quand vous travaillez sur ou à proximité de systèmes et d'équipements électriques.*
- *L'utilisation de l'AVT ne remplace pas les procédures de verrouillage/étiquetage. L'AVT est destiné à être utilisé conjointement avec les processus de verrouillage/étiquetage et ne traite que de l'absence d'étape de vérification de la tension.*
- *Utilisez un équipement de protection individuelle approprié (EPI) lorsque vous travaillez autour de sources d'énergie électrique dangereuse.*
- *N'utilisez pas ce produit en dehors des performances spécifiées et des limites environnementales.*
- *Ce produit doit être installé par un électricien qualifié familier avec les codes électriques locaux et nationaux.*
- *L'AVT ne fera que tester l'absence de tension au point où il est installé. S'il existe d'autres sources d'alimentation dans l'équipement, une tension dangereuse peut être présente.*
- *L'absence de tension est indiquée par l'illumination de l'indicateur vert d'absence de tension. L'absence de tension n'est pas garantie quand les indicateurs de présence de tension rouge ne sont pas éclairés.*
- *L'AVT doit être installé correctement et mis à la terre comme décrit dans ce manuel d'instructions pour fournir une indication appropriée de l'absence de tension. Les câbles du capteur ne doivent pas être connectés mécaniquement entre eux pour que l'appareil vérifie la connexion au circuit. La fonction correcte de l'appareil doit être vérifiée après l'installation (voir la liste de contrôle de mise en service).*
- *Les fils de capteur de la même couleur doivent être terminés sur le même conducteur. Chaque conducteur doit avoir au moins un fil de capteur, comme indiqué sur les diagrammes schématiques.*
- *La longueur excédentaire des câbles du capteur doit être découpée; Les câbles du capteur ne doivent pas être prolongés avec une épissure.*
- *Respectez toujours les codes et les normes d'installation locaux.*
- *L'AVT ne fonctionnera pas avec une batterie alcaline standard 1.5Volt AA. Utilisez uniquement les batteries homologuées indiquées dans le tableau indiqué dans la section Maintenance de ce mode d'emploi.*
- *Le produit utilise une batterie au lithium qui est un incendie, une explosion et un grave risque de brûlure. Ne pas écraser, recharger, démonter ou chauffer au-dessus de 85 ° C, incinérer ou exposer le contenu à l'eau.*
- *Utilisez uniquement le câble système AVT inclus ou les câbles de remplacement approuvés pour connecter le module d'isolement et le module indicateur. N'utilisez pas de câble Ethernet standard.*
- *La batterie, le câble du système AVT et les joints toriques (O-rings) peuvent être remplacés. Aucune autre partie du produit ne peut être réparée. N'essayez pas d'ouvrir le module indicateur ou le module d'isolement pour réparation ou modification. Lors de l'entretien de ce produit, utilisez uniquement des pièces de rechange spécifiées.*
- *La section du module indicateur externe à l'enceinte électrique est approuvée pour le lavage lorsqu'il est installé dans un boîtier approprié. Avant une opération de lavage, assurez-vous que les joints toriques sont en bon état, la plaque frontale est intacte et complètement fixée à l'unité et que le capuchon est complètement installé.*
- *Le câble du système AVT doit être séparé des fils du capteur et d'autres circuits dans l'enceinte électrique d'au moins 0,25 pouce (6 mm).*
- *Pour éviter d'endommager l'AVT dans des installations à vibrations élevées, montez le module d'isolement à l'aide de vis et fixez les fils conducteurs du capteur et le câble système AVT pour éviter toute contrainte sur les points de connexion.*
- *Si un conducteur de capteur se sépare du point de terminaison au conducteur d'alimentation et entre en contact avec une ligne à basse impédance, le test de connectivité peut être annulé, ce qui entraîne une fausse indication d'absence de tension. Assurez-vous que tous les fils du capteur sont correctement raccordés et fixés au conducteur d'alimentation ou à toute autre chose rigide à proximité pour éviter tout mouvement où cas si la terminaison ne reste pas intacte.*

En cas de problème lors de l'installation, du fonctionnement ou de la maintenance de VeriSafe AVT, contactez Panduit en utilisant l'un des supports techniques ou les numéros de service clientèle figurant sur le couvercle de ce manuel. Veuillez contacter Panduit si vous avez des problèmes de produits liés à la fonction de sécurité du produit. Le numéro de modèle du produit et le numéro de série sont imprimés sur les étiquettes du module d'isolement et du module indicateur.



VeriSafe est un produit contenant des cartes de circuits électroniques à la fois dans l'indicateur et les modules d'isolement. Le module indicateur contient une batterie au lithium. Lors du déclassement, retirez la batterie. Ne pas jeter la batterie dans la poubelle; passez-la à une installation appropriée de recyclage de la batterie. L'indicateur et les modules d'isolement peuvent être éliminés dans une installation de recyclage électronique.

Components

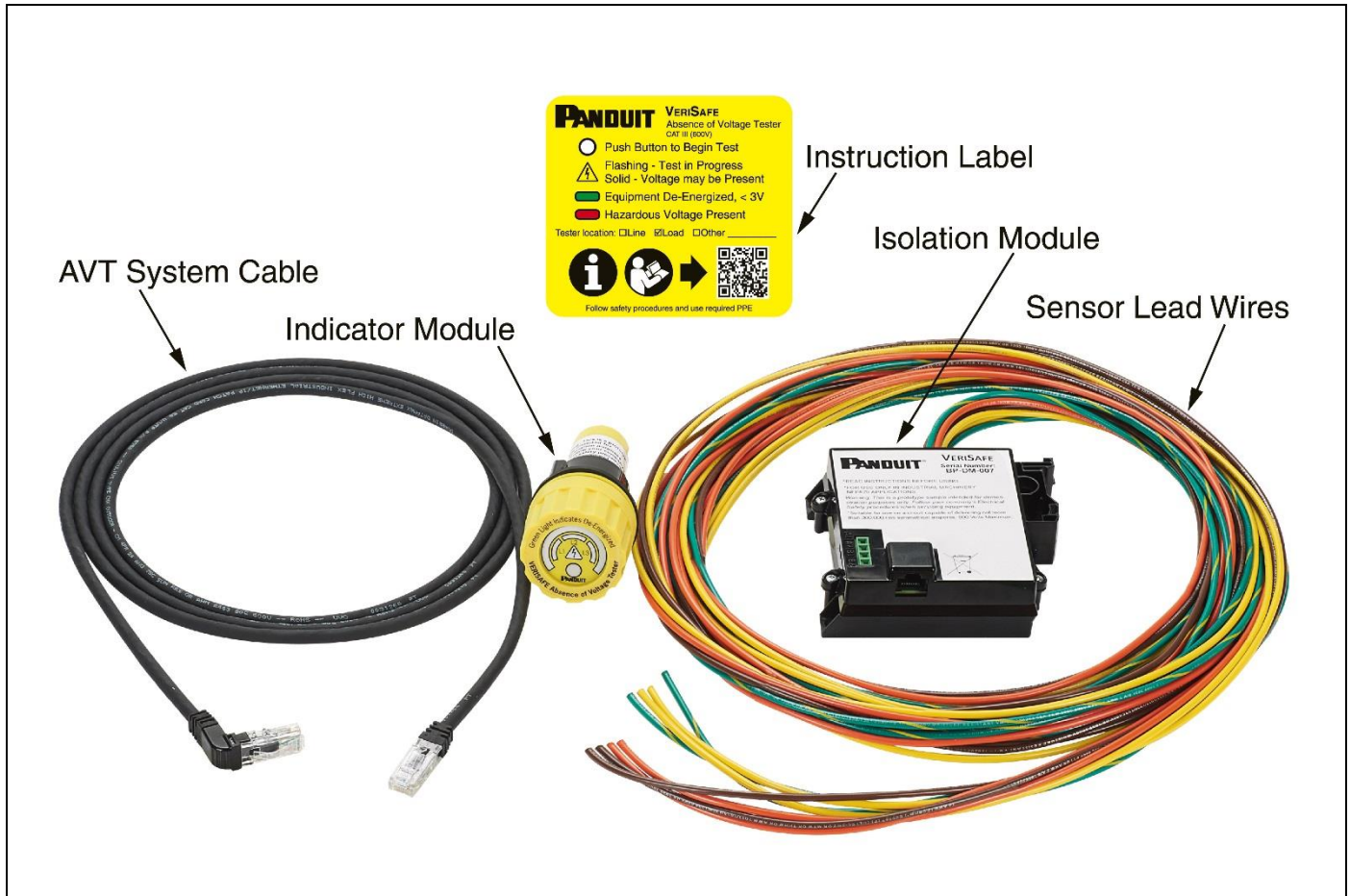

The components of the Panduit VeriSafe Absence of Voltage Tester (AVT)

Output Contacts

The AVT includes a set of redundant dry contact signal outputs for optional use with control systems. These contacts are located on the Isolation Module. The outputs are normally open and close only when the green Absence of Voltage Indicator is illuminated. By wiring to these contacts, the AVT can be used as an input to a control system as well as log when the absence of voltage was verified.

<p>Safety procedures when servicing a *Suitable for use on a circuit capable than 300,000 rms symmetrical amperes</p>	<p>Recommended Wiring</p> <p>For redundant monitoring of output state</p>	<p>Output Contact Specifications</p> <ul style="list-style-type: none"> • Two channel, single-pole, normally open • Relay closure upon absence of voltage verification • 5000 Vrms Input/Output Isolation • Contacts rated for 30 V AC/DC • Load Current 80 mA AC rms / mA DC • On-Resistance 30 Ω (max) • Compatible with up to 16 AWG (1 mm²) • SIL3 compliant • Duty Cycle: 10 seconds per test cycle
---	--	---

Technical Specifications



Warning: Do not use this product outside of the specified performance and environmental limits. Failure to comply with these specifications could result in product failure, personal injury, or death.

Standards

UL 1436	Standard for outlet circuit testers and similar indicating devices
CAN/CSA-C22.2 No. 160	Voltage and Polarity Testers
IEC / UL / CSA C22.2 NO. 61010-1	Safety requirements for electrical equipment for measurement, control, and laboratory use – Part 1: General Requirements
IEC / UL / CSA C22.2 NO. 61010-2-030	Safety requirements for electrical equipment for measurement, control, and laboratory use – Part 2-030: Particular requirements for testing and measuring circuits
UL 508 & CSA-C22.2 No. 14	Industrial control equipment
IEC 61508-1, -2, and -3 (SIL 3 Rating)	Safety of Electrical/Electronic/programmable Electronic safety-related security systems – Part 1 General Requirements Part 2 Requirements for Electrical / Electronic / Programmable safety related systems Part 3 Software Requirements
FCC - CFR 47 Part 15 Subpart B	Radio frequency devices
IEC 61326-1, -3-1, -3-1: corr 1 EN 61326-1, -3-1	Electrical equipment for measurement, control and laboratory use-EMC requirements - Part 1 Part 3-1: Immunity requirements for safety-related systems and for equipment intended to perform safety-related functions (functional safety) - General industrial applications including corrigendum 1
EN 55011, CISPR 11	Industrial, scientific and medical equipment - Radio-frequency disturbance characteristics - Limits and methods of measurement
IEC / EN61000-3-2 IEC / EN61000-3-3	Electromagnetic compatibility (EMC) - Part 3-2: Limits — Limits for harmonic current emissions (equipment input current ≤ 16 A per phase)
EN 61000-6-2	Electromagnetic compatibility (EMC) - Part 6-2: Generic standards - Immunity for industrial environments
KN 61000-6-2 KN 61000-6-4	In an industrial environment, General immunity Test Method Preventing interference in industrial environments, Test Method
AS/NZS CISPR 11	Australian / New Zealand Standard - Industrial, scientific and medical equipment—Radio-frequency disturbance characteristics—Limits and methods of measurement
CAN - ICES-001	Industrial, Scientific and Medical (ISM) radio frequency generators.
CE	Conformity Marking for European Economic Area
RoHS	Restriction of hazardous substances

NOTE: By design and installation guidelines the VeriSafe AVT is not impacted by the occurrence of phenomena from IEC 61000-4-16

Applications

Electrical System	For use in 1 and 3-phase AC systems
Voltage Detection Range	Up to 600V AC (50/60Hz), 600V DC; Rated tolerance +10%
Absence of Voltage Threshold	3 V (See the Installation Considerations section for additional information)
Overvoltage Category	III (600 V), IV (300 V)
Degree of Protection*	Indicator Module: For Flat Surface Mounting in a TYPE (UL, NEMA and CSA) 1, 12, 4, 4X, 13, IP66, or IP67 Enclosure, Isolation Module: Open Type, IP20

*Degree of protection specified is related to the Indicator Module only. To meet the TYPE (UL, NEMA and CSA) 1, 12, 4, 4X, 13, IP66 or IP67 requirements, mount on a flat surface of an enclosure meeting the appropriate UL TYPE or NEMA rating. Verify that the seal and o-rings are clean to ensure proper sealing.

Environment

Operating Temperature	0°C to 60°C (32°F to 140°F)
Storage Temperature	-45°C to 85°C (-49°F to 185°F)
Humidity	5 to 90% non-condensing; Rated 80% at 40°C, decreasing linearly to 50% at 60°C
Pollution Degree	3
Altitude	Up to 5000 meters (3.1 miles)

Battery

Type	Industrial 3.6V Lithium AA, see table in Maintenance section for list of compatible batteries.
-------------	--

Functional Safety

Mode of operation	Continuous, High Demand				
Failure Rate	λ_{SD}	λ_{SU}	λ_{DD}	λ_{DU}	SFF
	65	371	152	10	98.3%
Supported Safety Integrity Levels	SIL3				
Demand Response Time	10.1 Seconds				
Device Type	Type A				
Systematic Capability	SC 3				
Error Handling Response Time	10.3 Seconds				
Reference Report	PAN 16/01-050 R003				
Operating Modes	SIL mode only				

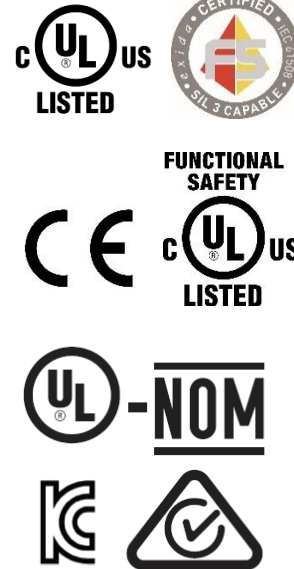

Dimensions
Isolation Module

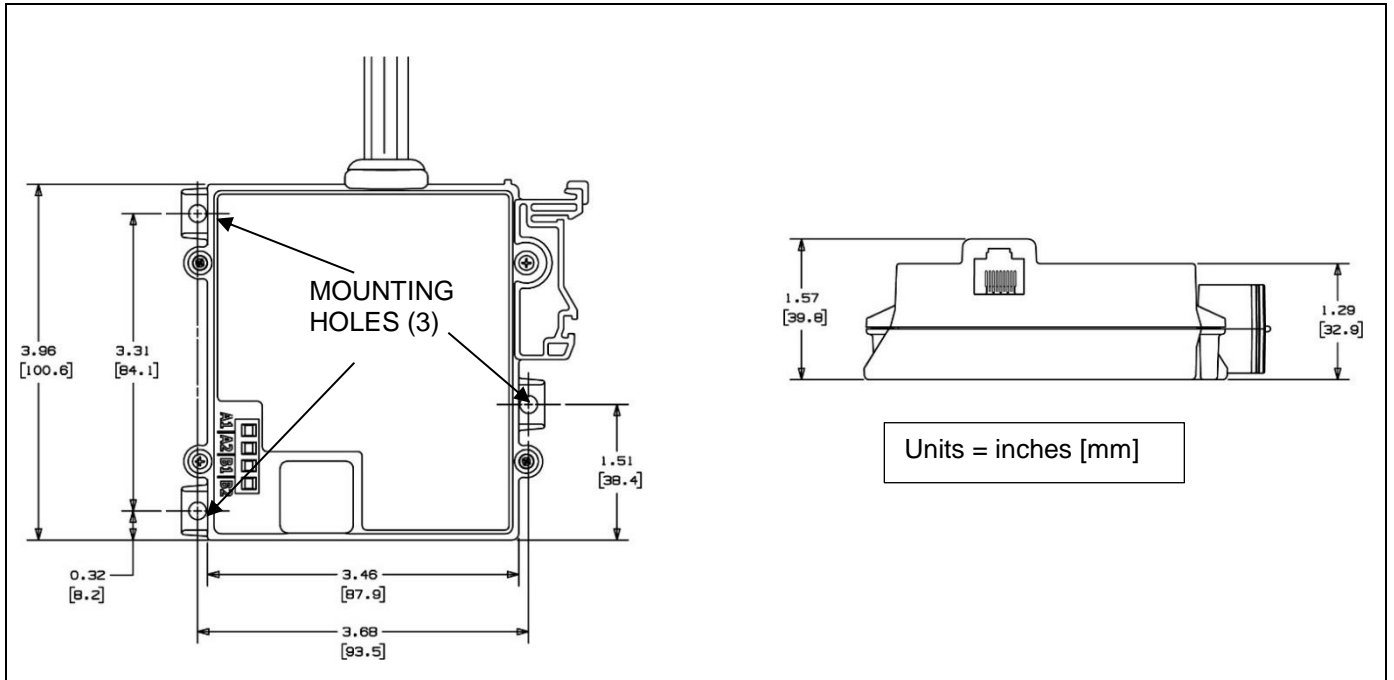

Indicator Module

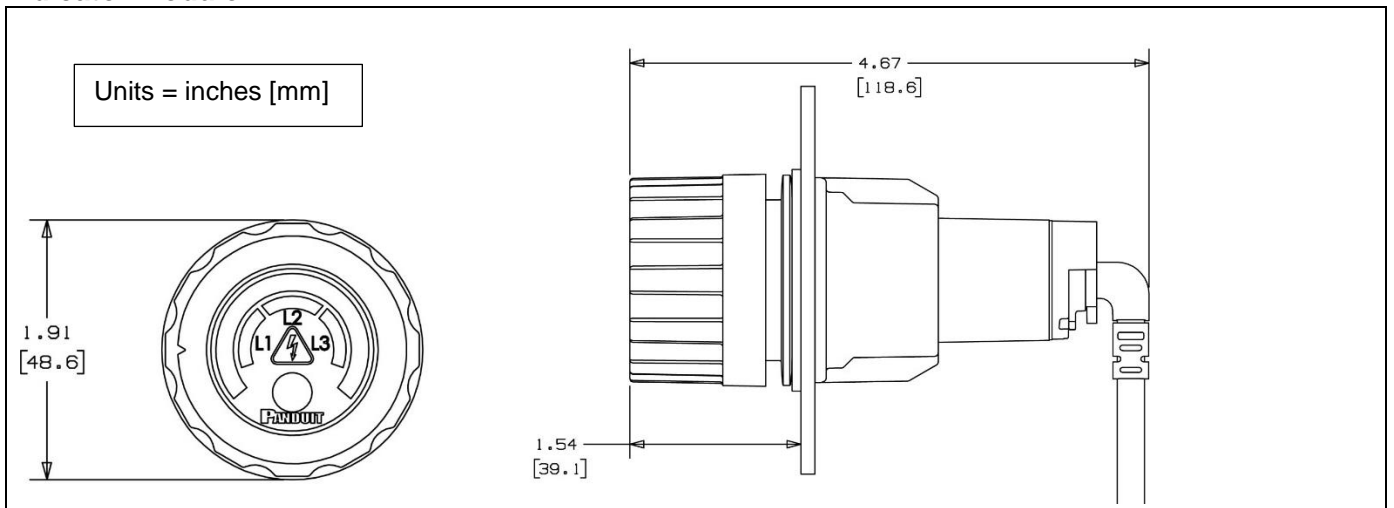

Panel Knockout

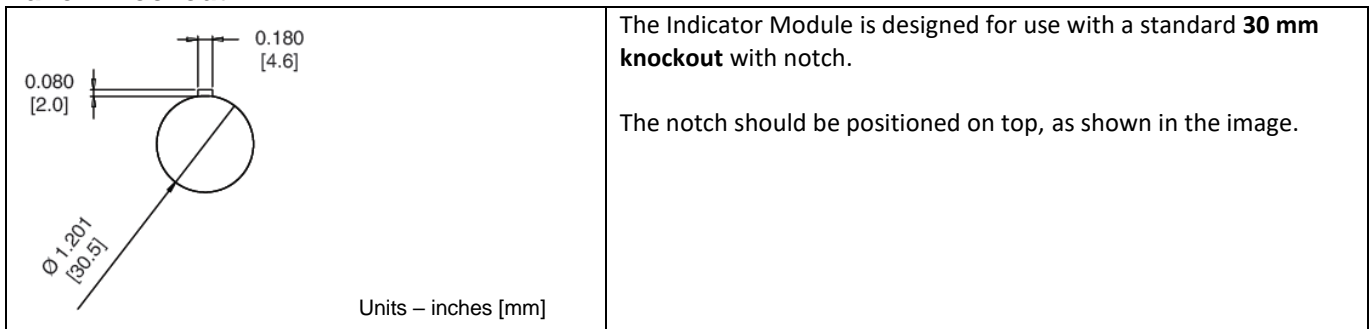

Schematics



Warning:

- The AVT must be installed correctly and grounded as described in this Instruction Manual to provide proper indication of absence of voltage. Sensor leads must not be mechanically connected with each other for the device to verify connection to the circuit. Correct function of the device must be verified after installation (see commissioning checklist). Failure to comply with these instructions could result in product failure, injury or death.
- Sensor leads of the same color should be terminated on the same conductor. Each conductor should have at least one sensor lead set, as shown on the schematic diagrams.
- If a Sensor Lead separates from the termination point to the power conductor and contacts a low impedance path to ground, the connectivity test can be defeated resulting in a false absence of voltage indication. Ensure that all sensor leads are terminated properly and secured to the power conductor or other nearby rigid feature to prevent movement if the termination fails to remain intact.

Three-Phase Delta: 3 Wire + PE

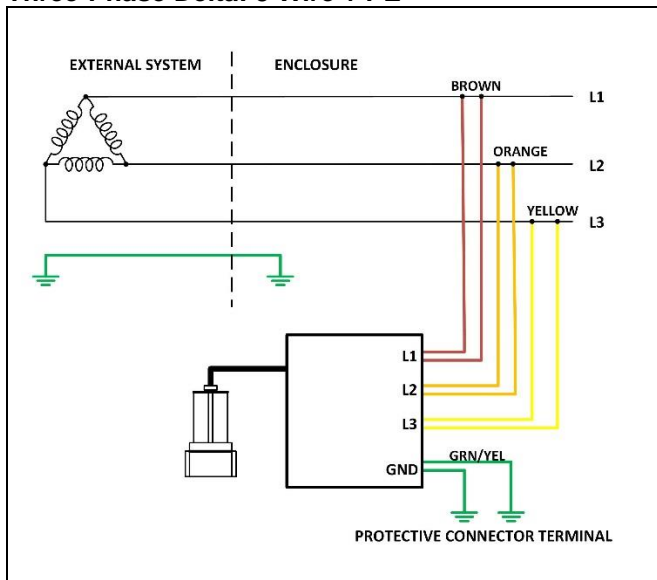

Three-Phase WYE: 3 Wire + Neutral and PE

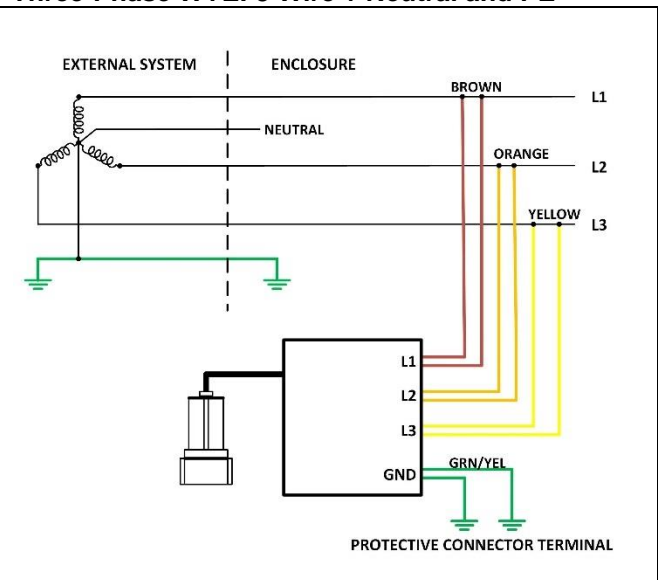

Three-Phase WYE: 3 Wire + PE (No Neutral)

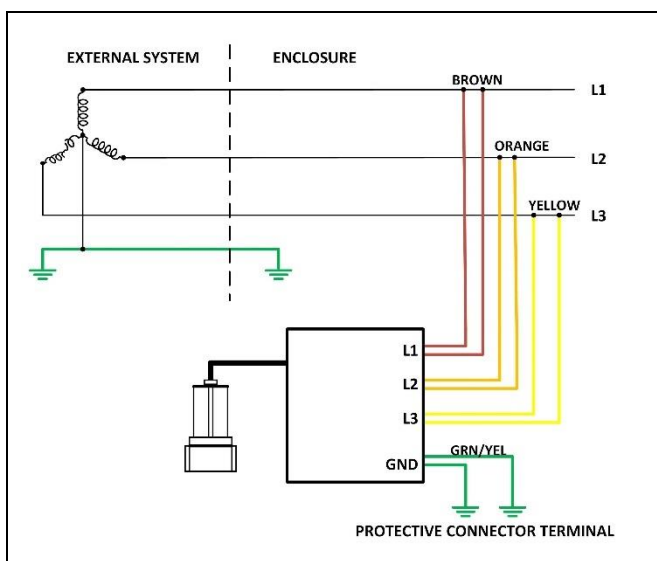

Three-Phase WYE High Resistance Ground: 3 Wire + Neutral and PE

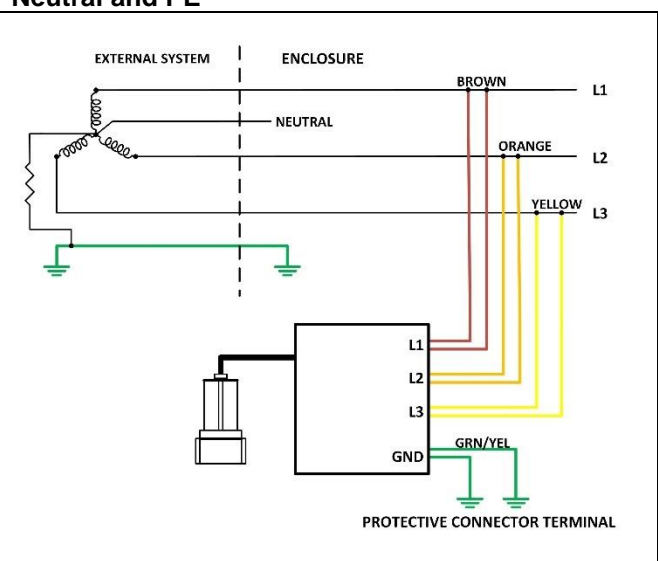

Single-Phase: 2 Wire + PE

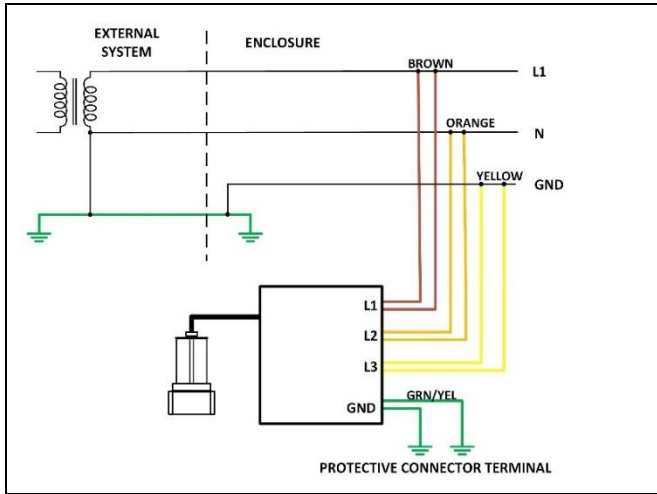

Single-Phase: 2 Wire + PE, Redundant Detection Lead

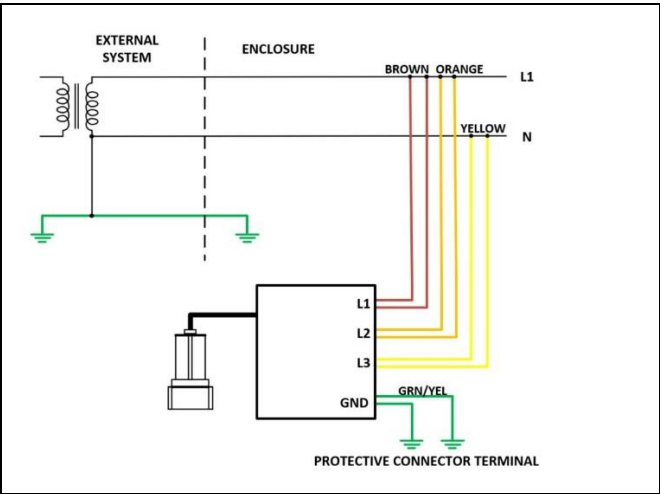

Single-Phase: 3 Wire + PE

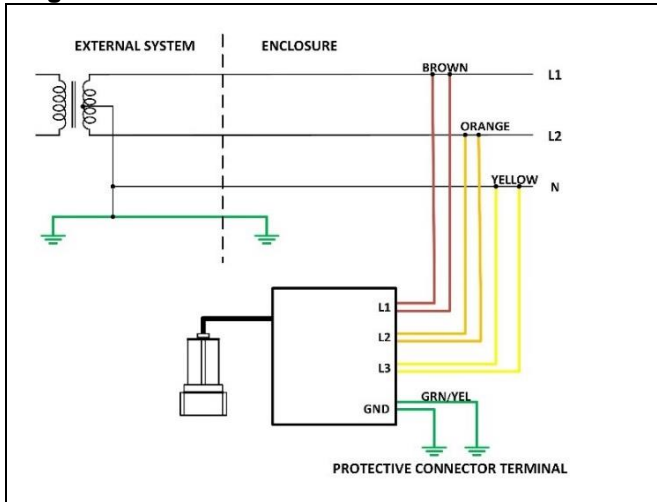

Corner Grounded DELTA: 3 Wire + PE

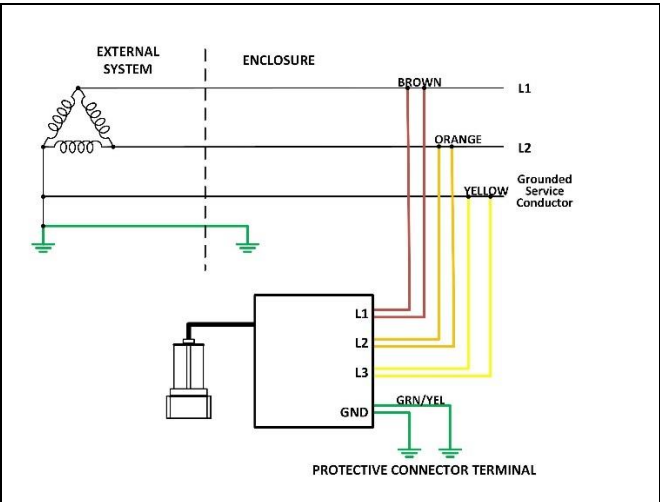

High-Leg DELTA: 3 Wire + Neutral + PE

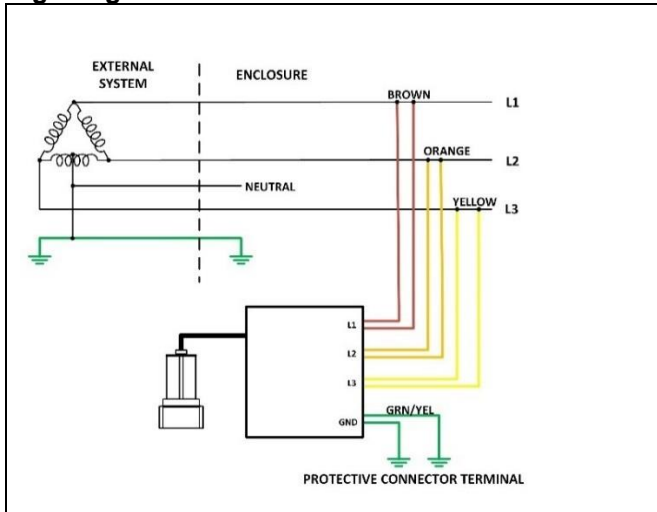

DC System: 2 Wire + PE

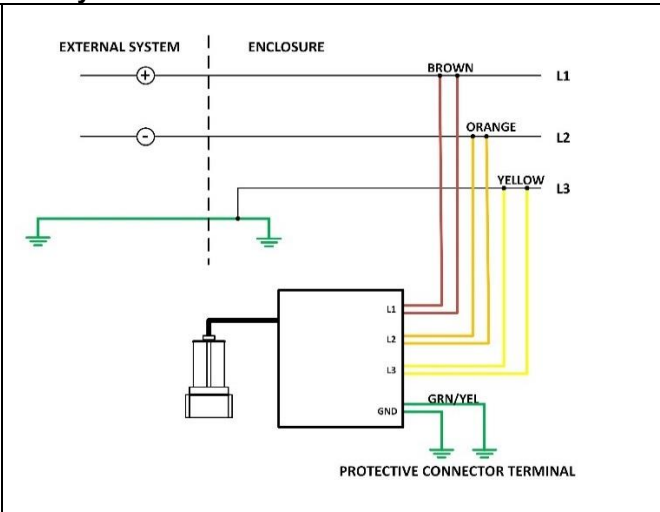

DC System: 2 Wire + PE, Redundant Detection Lead

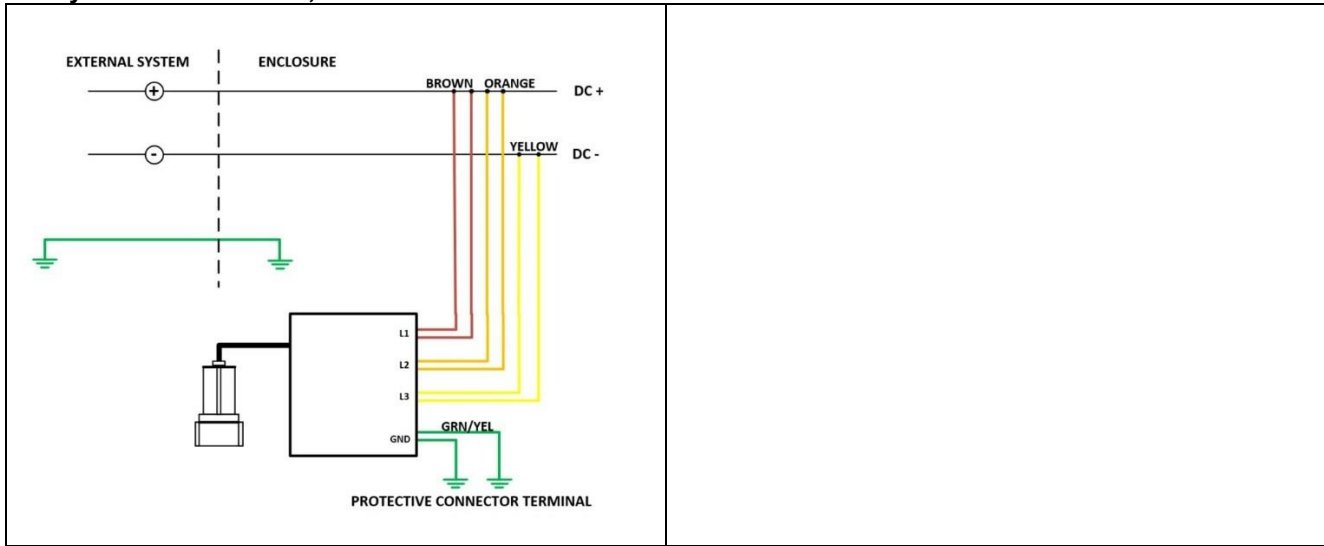

Schematics – Europe (EU)



Warning:

- *The AVT must be installed correctly and grounded as described in this Instruction Manual to provide proper indication of absence of voltage. Sensor leads must not be mechanically connected with each other for the device to verify connection to the circuit. Correct function of the device must be verified after installation (see commissioning checklist). Failure to comply with these instructions could result in product failure, injury or death.*
- *Sensor leads of the same color should be terminated on the same conductor. Each conductor should have at least one sensor lead set, as shown on the schematic diagrams.*
- *If a Sensor Lead separates from the termination point to the power conductor and contacts a low impedance path to ground, the connectivity test can be defeated resulting in a false absence of voltage indication. Ensure that all sensor leads are terminated properly and secured to the power conductor or other nearby rigid feature to prevent movement if the termination fails to remain intact.*

Three-Phase Delta: 3 Wire + PE

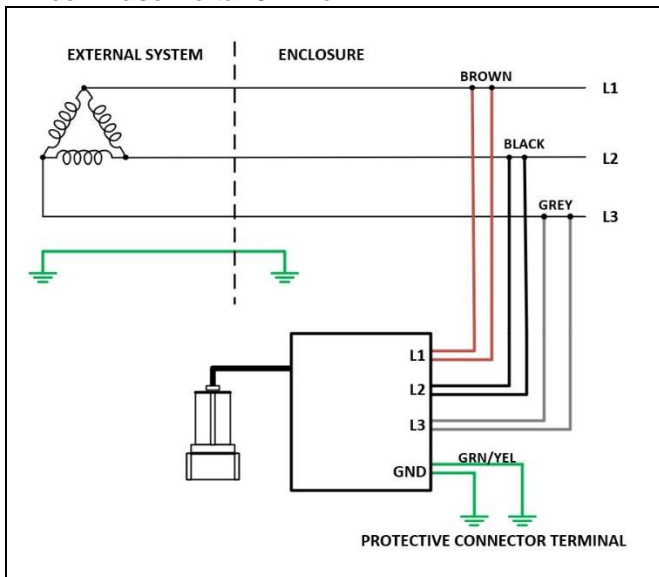

Three-Phase WYE: 3 Wire + Neutral and PE

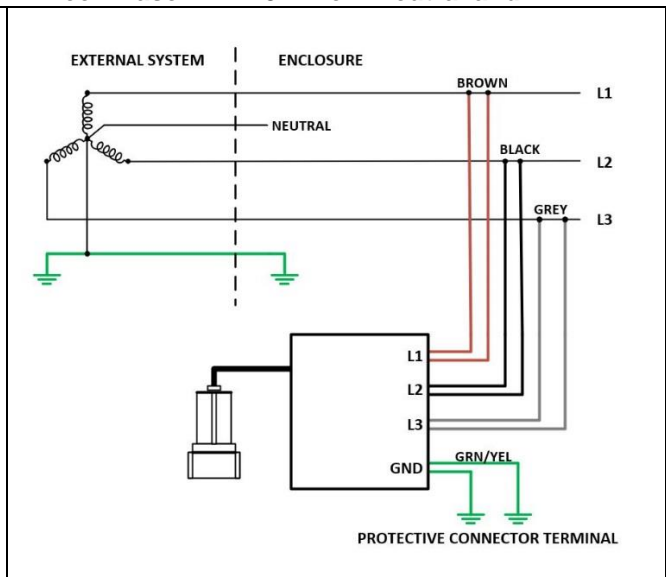

Three-Phase WYE: 3 Wire + PE (No Neutral)

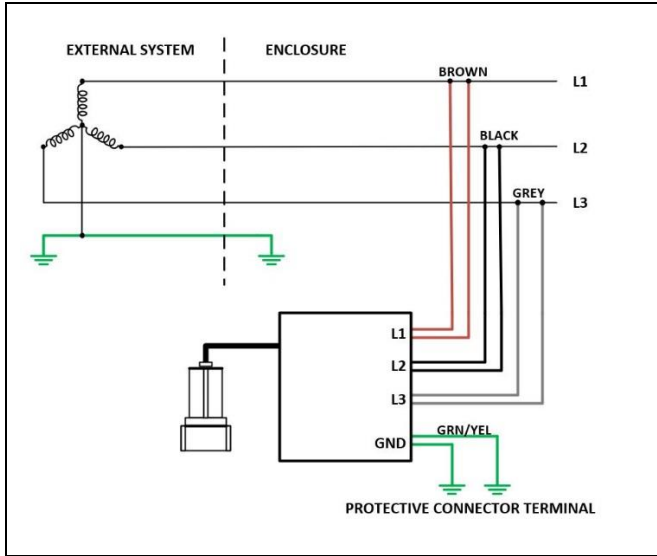

Three-Phase WYE High Resistance Ground: 3 Wire + Neutral and PE

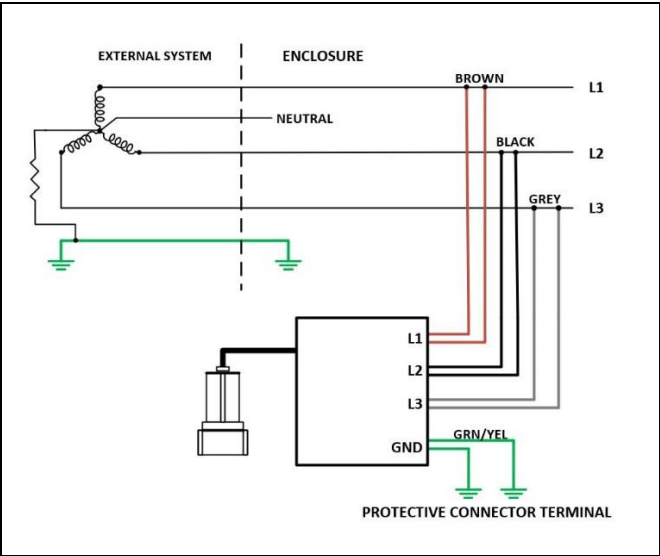

Single-Phase: 2 Wire + PE

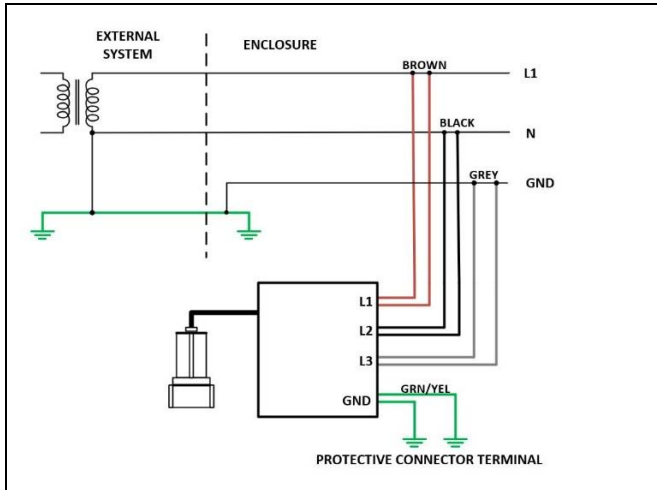

Single-Phase: 2 Wire + PE, Redundant Detection Lead

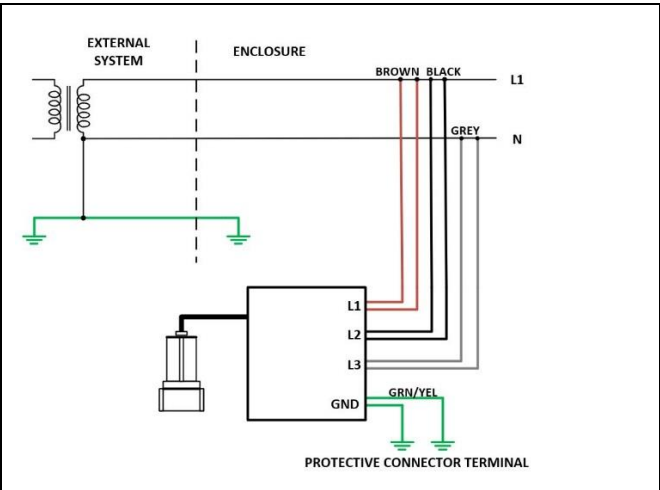

Single-Phase: 3 Wire + PE

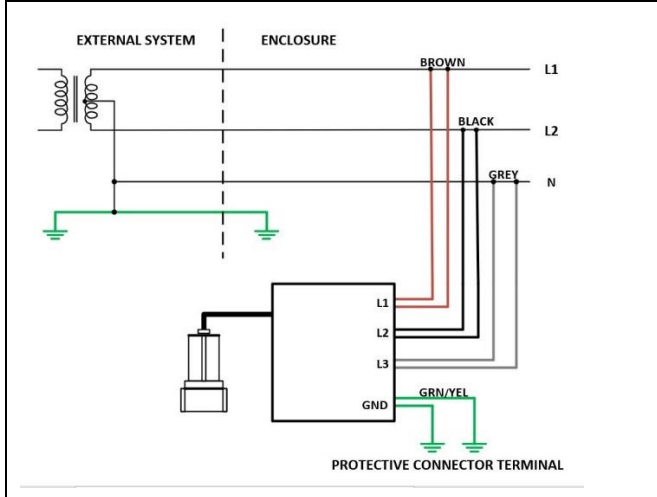

Corner Grounded DELTA: 3 Wire + PE

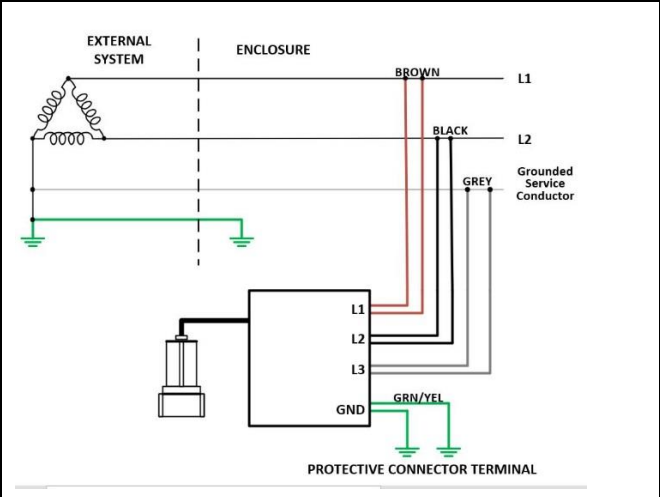

High-Leg DELTA: 3 Wire + Neutral + PE

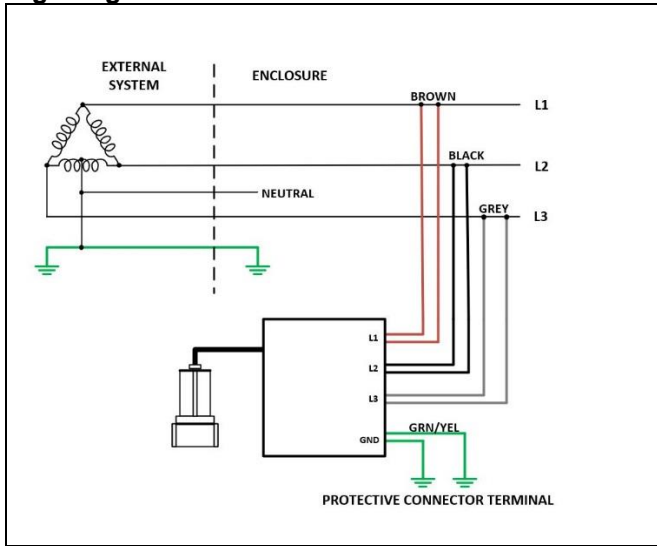

DC System: 2 Wire + PE

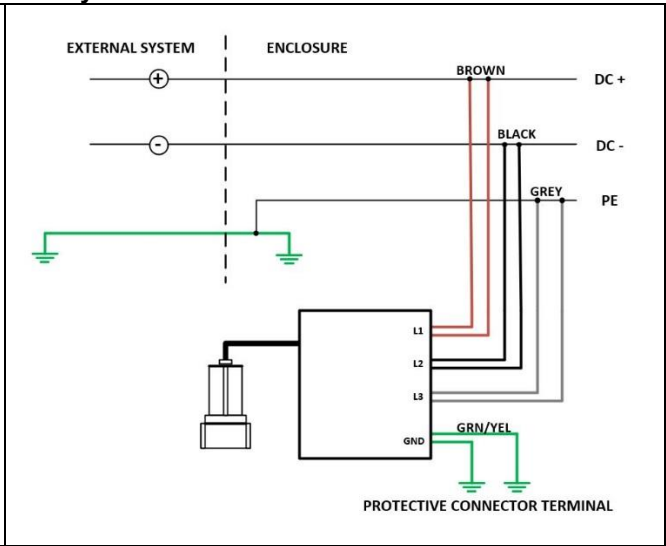

DC System: 2 Wire + PE, Redundant Detection Lead

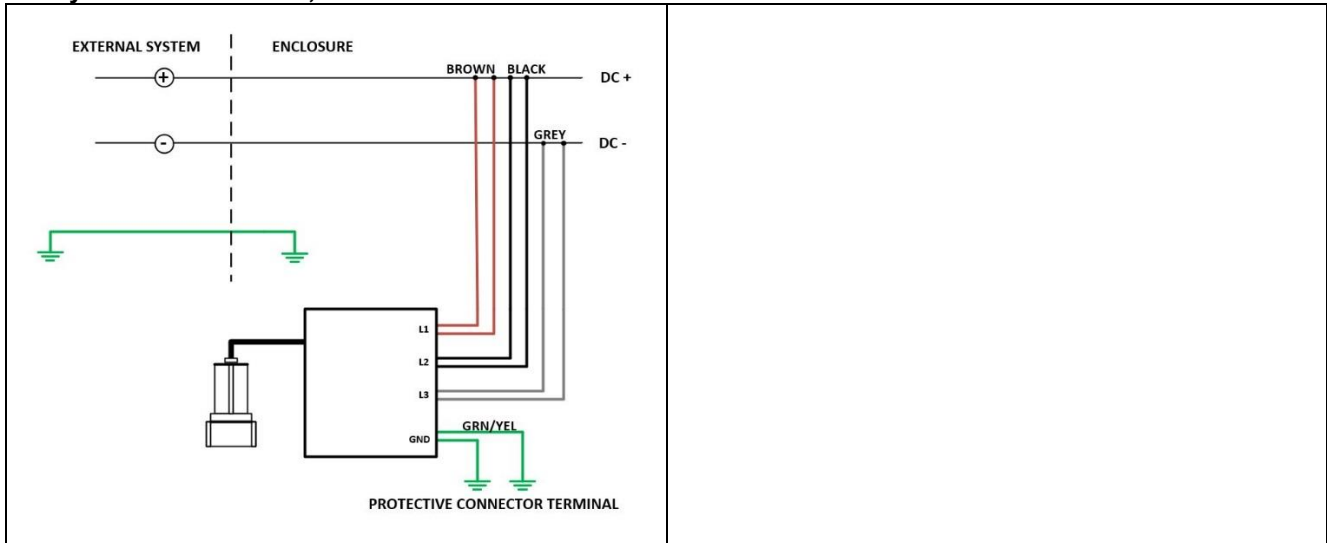

Installation Considerations

This section provides guidelines for installing VeriSafe Absence of Voltage Testers (AVTs). It also addresses several common application scenarios and describes best practices.

General Information

Before installing the AVT, identify all sources of electrical energy in the equipment. Install the AVT at the point in the circuit where you would normally test for voltage. The AVT will only test for voltage at the point where it is installed. If there are multiple energy sources or multiple test points, consider using multiple AVTs.

The AVT may be installed on the supply (line) or load side of an electrical disconnect. When the AVT is installed, mark the test location on the yellow Instruction Label. Apply this label to outside of enclosure near the Indicator Module.

The Voltage Presence indicators only illuminate red when hazardous AC voltage is detected. The absence of voltage test will verify absence of any voltage (AC and DC) before the Absence of Voltage Indicator is illuminated green.

The AVT is required to be solidly grounded and bonded to the protective conductor terminal of the enclosure. Review the Schematics section of this Instruction Manual. Although the absence of voltage threshold is 3.0 V, residual voltages should be less than 1.3 V to ensure optimal reliability.

When installing an AVT, care should be taken to ensure that Sensor Leads used to connect the AVT to the circuit conductors and to ground shall not be any longer than necessary and shall be routed to avoid sharp edges, pinch points or mechanical damage. Do not extend the sensor leads with a splice.

Always follow instructions in this Instruction Manual. Do not exceed specified environmental or performance limits.

Effect on Short Circuit Current Rating (SCCR)

AVTs listed to UL 1436 are required to operate as a secondary circuit that is isolated from the circuit conductors by use of a transformer, optical isolator, or limiting impedance, or other similar means. This is intended to reduce the risks of both electric shock and thermal hazard. These isolation circuits allow very limited current flow, if any, through the AVT.

The VeriSafe AVT is suitable for use on circuits delivering up to 300,000 rms symmetrical A at 600 V.

Use of Overcurrent Protection

Installation of overcurrent protection is not required for safe operation of the VeriSafe AVT. UL 1436 requires AVTs to be constructed so that internal component failures will not expose the AVT to available short circuit currents from the main power supply during normal operation and under single-fault conditions. The VeriSafe AVT Isolation Module uses high impedance to limit voltage and current flow through the device to safe levels. In addition, the VeriSafe AVT has been tested to withstand transient overvoltage up to 6 kV. In the US, the sensor leads of the AVT can be treated as a feeder circuit per NEC article 240.21(B)(1)(b) Exception (NFPA 70:2017). This rule allows a tap of no more than 10 feet on a feeder circuit without the need for overcurrent protection.

Other local wiring codes and regulations may require use of overcurrent protection. Always follow applicable codes and standards when installing the device. The VeriSafe AVT can be installed safely with overcurrent protection. When installing overcurrent protection with the VeriSafe AVT, it is important to install one overcurrent protection device for each of the six sensor leads. Overcurrent protection should not be installed with the two green ground leads. *Do not install multiple lead wires on one overcurrent protection device in a configuration that would leave lead wire pairs electrically connected in the event that the overcurrent protection is in the open state.*

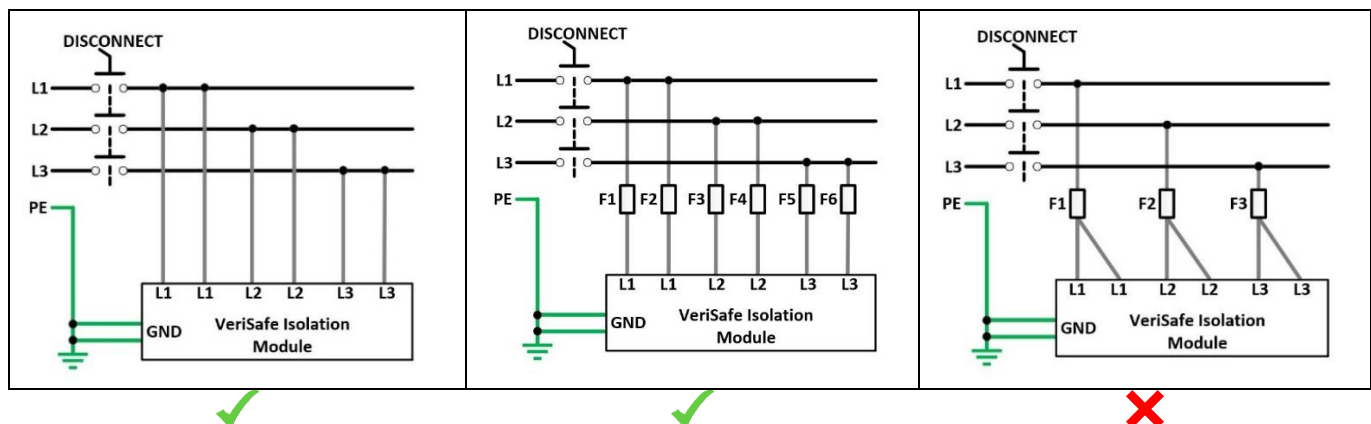

Termination Recommendations

The VeriSafe AVT is provided with a total of (8) 14 AWG (2 mm²) sensor leads (two sensor leads for each phase conductor and ground connection point). Sensor leads for each phase and ground must not be mechanically connected to each other for the AVT to function properly (see step 7 in the Installation Instructions). The second lead on each phase provides the ability for the AVT to verify that it is in contact with the circuit conductors (each phase and ground) when the absence of voltage test takes place. It is also part of the mechanism that is used to “test-the-tester” to validate that the AVT is functioning. There is no maximum distance limitation between the two leads on each phase, however there should not be any circuit elements installed between them. Do not extend the sensor leads with a splice. Use approved connection methods and follow local codes and standards when terminating the sensor leads.

Terminations should be made via a tap to the circuit conductor using connectors, terminal strips, or power distribution blocks, etc. which are rated for the application. It is generally preferred to use connection methods that do not pierce or otherwise compromise the integrity of the conductor. Connectors that require conductors to be cut or spliced can be used but may limit the SCCR.

Connectivity Test

Each time the absence of voltage test is initiated, the VeriSafe AVT performs a series of diagnostics and checks in addition to testing for absence of voltage. One step in this sequence involves a “connectivity test.” The purpose of the connectivity test is to ensure that each detection lead is in contact with a conductor.

The VeriSafe AVT is designed with two Sensor Leads for each phase conductor. The two leads in each color set have different functions. The Detection Lead is used to detect voltage and the Termination Lead is used to verify that the Detection Lead is in contact with a conductor. The Termination Lead does not detect voltage. There are no labels distinguishing the Detection and Termination Leads because it is critical that they are both properly terminated. If the Detection Lead is not contacting a conductor, the connectivity test will fail and prevent the AVT from returning a Green Absence of Voltage indication.

The connectivity test is performed by measuring the discharge time of a capacitor inside the Isolation Module that is electrically connected to the detection lead. If the Detection Lead is electrically connected to the Termination Lead, the discharge time will be inside the desired range and the test will pass. If the Detection Lead is not in contact with a conductor, the discharge time will be outside of the desired range and the test will fail. If the connectivity test fails on any Detection Lead, the green absence of voltage indicator on the AVT will not illuminate.

IMPORTANT: *If the detection lead is not properly terminated to a power conductor and comes in contact with a low impedance path to ground, the discharge time could be inside the desired range and the connectivity test would pass. This would be a multi-fault scenario, but is possible if terminations are not made properly and secured. An AVT installed on a single-phase system might only have one Detection Lead terminated to a power conductor. If the Detection Lead were to become loose and make contact with a low impedance path to ground, the connectivity test would pass. However, voltage would not be detected because the termination lead does not detect voltage and the Detection Lead is no longer in contact with the power conductor. This could result in a green absence of voltage indication, even though the power conductor is energized. This would be less likely to occur with split-phase or three-phase systems as all Detection Lead terminations would need to fail and each detection lead would have to make contact with a low impedance path to ground at the time of the test. However, even the loss of a single detection lead termination on a multi-phase system could result in the scenario described above, if voltage was only present on a single phase.*

Utilization of the commissioning test described in this Instruction Manual will verify proper functionality of the AVT at the time of installation. The failure modes described in this section would be the result of Sensor Lead terminations not being maintained over time and Sensor Leads not being secured to the power conductors at time of installation. This likelihood of this scenario can be reduced by securing the Sensor Leads to the power conductor or another nearby rigid feature to prevent movement in the event that the termination point failed. Sensor Leads can be secured using cable ties, clamps, mounts or tape. The sensor leads should be secured at multiple locations, including near the termination point. Additionally, the Schematics section of this Instruction Manual provides redundant detection schematics for both single-phase and DC installations to provide a redundant Detection Lead on the power conductor.

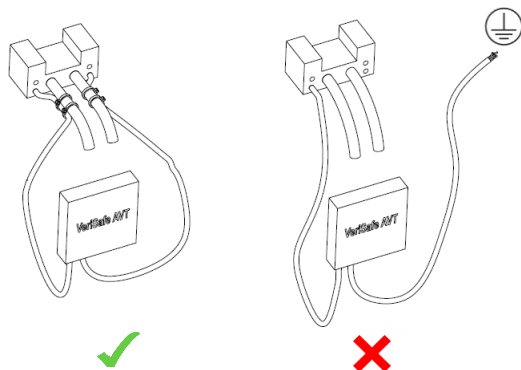

Warning:

Secure Sensor Leads to prevent accidental contact with ground.

Installation Instructions



Warning:

- *The AVT must be installed correctly and grounded as described in this Instruction Manual to provide proper indication of absence of voltage. Sensor leads must not be mechanically connected with each other for the device to verify connection to the circuit. Correct function of the device must be verified after installation (see commissioning checklist).*
- *Sensor leads of the same color should be terminated on the same conductor. Each conductor should have at least one sensor lead set, as shown on the schematic diagrams.*
- *Excess length from Sensor Leads should be trimmed; lead wires should not be extended with a splice.*
- *Always comply with local installation codes and standards.*
- *Always follow safety and lockout/tagout procedures when working on or near electrical systems and equipment.*
- *If a Sensor Lead separates from the termination point to the power conductor and contacts a low impedance path to ground, the connectivity test can be defeated resulting in a false absence of voltage indication. Ensure that all sensor leads are terminated properly and secured to the power conductor or other nearby rigid feature to prevent movement if the termination fails to remain intact.*

Before installation, verify that after power is removed from the circuit to be monitored, the potential measured between each line and ground is less than 1.3 V.



1. Insert the Indicator Module in the 30mm knockout hole, align anti-rotation notch. Ensure the rubber washer is on the outside of the enclosure.

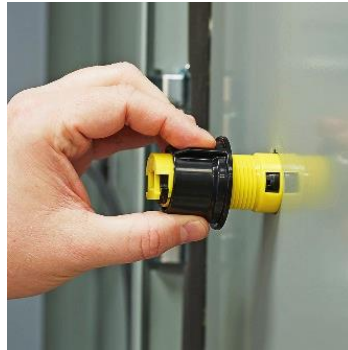

2. Install the panel nut with the flange towards the inside surface of the enclosure.



3. Tighten the panel nut until both it and the sealing washer make full contact with the enclosure surface. Then, tighten an additional $\frac{1}{4}$ turn. Tighten the panel nut with fingers only, do not overtighten.

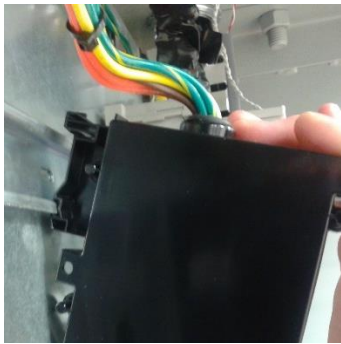

4. Snap the Isolation Module on the DIN rail. Alternately, the Isolation Module can be mounted to any surface using three, #8 pan head screws or another compatible fastener. Surface mounting with screws is recommended for high-vibration environments.

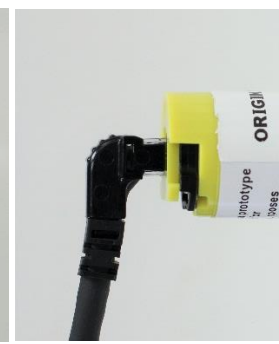

5. Insert the end of the AVT System Cable with the right-angle connector in the back of the Indicator Module. Press firmly into the opening until you feel it latch. Pull back on the connector to verify that it has properly latched.



6. Insert the other end of the AVT System Cable in the connector on the bottom of the Isolation Module.

System Cable should be secured using cable mounts or other means to provide strain relief and prevent damage. Verify that the enclosure door will open and close without straining the System Cable.

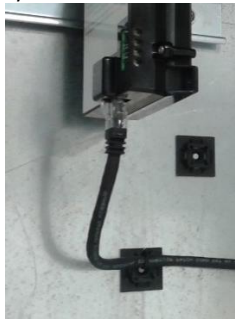

7. Terminate the sensor and ground leads. Secure the sensor leads to the conductors and insulate the connections.

- Sensor leads for each phase and ground must not be in direct contact with each other for the AVT to function properly as shown in the figure.
- Sensor leads of the same color should be terminated on the same conductor. Each conductor should have at least one sensor lead set, as shown on the schematic diagrams.
- There is no maximum distance limitation between the two leads on each phase, however there should not be any circuit elements installed between them.
- Do not extend the sensor leads with a splice.
- Use approved connection methods and follow local codes and standards when terminating the sensor leads.
- Secure the sensor leads to the conductors to prevent the leads from contacting ground if the termination fails.
- Refer to the Installation Considerations section for additional information.



8. Route Sensor Leads and AVT System Cable to avoid sharp edges, pinch points and prevent mechanical damage.

Secure the Sensor Leads with cable ties, clamps, mounts or tape to provide strain relief and prevent movement in the event that the termination point failed.



Insulate the terminations.



9. Install Instruction Label directly under or next to the Indicator Module on the exterior of the enclosure (see Note 1). Mark the label to indicate where in the circuit the AVT is installed.



10. Install the Cap Label with the appropriate language, if other than English.



11. Install the battery. See Battery Replacement section of the manual for further details.

Note 1: The Instruction Label is UL approved for application to galvanized and stainless steel, ABS, polycarbonate, and polyester painted surfaces. It is up to the installer to verify proper bond to other surface types.

Commissioning Checklist:

- Visually inspect the AVT:
 - **AVT system cable:** Verify cable is locked into place on both the Indicator Module and Isolation Module.
 - **Indicator module:** Ensure o-ring is in place. Check that retaining nut is secure. Verify battery is installed and battery cap is locked into place.
 - **Isolation module:** Ensure module is secured to subpanel or DIN rail.
 - **Sensor leads:** Gently pull on each Sensor Lead to ensure termination is secure. Verify that the Sensor Leads are secured to the power conductors or other nearby rigid feature to prevent movement and contact with a ground if the termination fails to remain intact. Verify no wiring is exposed and all terminations are properly insulated. Verify panel is clean and wiring debris is removed from panel. Verify that leads are connected as described in the appropriate wiring diagram from the Schematics section, including verifying that each conductor has two lead wires of matching color attached. Verify leads on each phase are not mechanically connected to each other.
 - **Instruction label:** Verify that the label is placed near the isolation module and marked to indicate where the AVT is installed.
- Record changes to panel documentation.
- Close panel and secure doors/covers.
- Press the Test Button to initiate the test. The yellow Caution Indicator should flash rapidly to indicate the test is in progress followed by the Absence of Voltage Indicator illuminated green.
- Review the Operating Instructions section of this manual before proceeding.



Warning: *Always follow your company's safety procedures when energizing equipment. To avoid electric shock, use proper personal protective equipment when working on or near electrical hazards.*

- Energize the system being monitored by the AVT.
- Verify that the red Voltage Presence Indicators are illuminated.
- Press the Test Button on the Indicator Module to initiate the absence of voltage test.
- Look for the yellow Caution Indicator to flash repeatedly before turning to a solid indication. ****You should not see the green indicator illuminate when power is energized.****
- De-energize the circuit that is being monitored by the AVT.
- Verify that Voltage Presence Indicators are not illuminated.
- Press the Test Button on the AVT Indicator Module to begin the absence of voltage test. Look for the yellow Caution Indicator to flash and then the green Absence of Voltage Indicator should illuminate.

Operating Instructions



Warning:

- **To avoid electric shock, always de-energize power before entering an electrical enclosure.**
- **Always follow safety and lockout/tagout procedures when working on or near electrical systems and equipment.**
- **Use proper personal protective equipment (PPE) when working around sources of hazardous electrical energy.**
- **Absence of voltage is indicated by illumination of the green Absence of Voltage Indicator. Absence of voltage is not guaranteed when the red Voltage Presence Indicators are not illuminated.**

The AVT should only be operated by individuals who have been trained on the operation of the tester and can demonstrate knowledge of the following criteria:

- Familiar with requirements and information in the Instruction Manual and understand the function of the AVT, meaning of the indicators and markings, and limitations of the Voltage Presence Indicators
- Aware of where the AVT is installed in the electrical system and any additional electrical hazards that may be present in the system that are not detectable by the AVT
- Able to recognize electrical hazards and familiar with lockout/tagout procedures

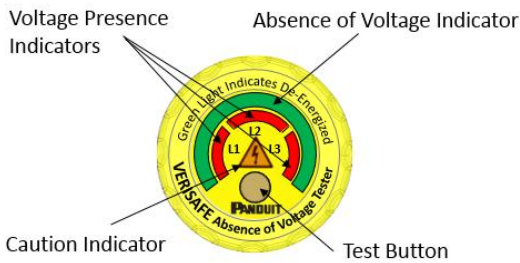

Test Button: Initiates test

Absence of Voltage Indicator: Illuminates **green** when the Absence of Voltage is verified

Caution Indicator: Flashes **yellow** rapidly to indicate test in process, illuminates solid to indicate the test has failed and flashes after a solid illumination to indicate the reason for failure

Voltage Presence Indicators: Three **red** indicators illuminate when the presence of hazardous AC voltage is detected. **Absence of voltage is not guaranteed when the Voltage Presence Indicators are not illuminated.**

<p>Voltage Presence Indicators</p> <p>A. When voltage is detected in one or more phases, the appropriate Voltage Presence Indicators will illuminate.</p> <p>B. Absence of voltage is not guaranteed when the Voltage Presence Indicators are not illuminated. To test for absence of voltage, push the Test Button.</p>	<p>A.</p>	<p>B.</p>
<p>Absence of Voltage Test</p> <p>Each time the Test Button is engaged, the absence of voltage test sequence will be activated. The test sequence includes running a self-check, using a known voltage source to test the tester to verify that the AVT is functioning, testing for AC and DC voltage phase-to-phase and phase-to-ground, and verifying the sensor leads are in contact with the circuit conductors.</p> <ol style="list-style-type: none"> 1. De-energize the circuit according to company safety procedures. 2. Verify that lockout/tagout devices have been applied to all applicable energy sources and the Voltage Presence indicators are not illuminated. 3. Press the Test Button to initiate the absence of voltage test. 4. The Caution Indicator will begin to flash. This indicates that the test is in progress. 5. When the absence of voltage is verified, the Absence of Voltage Indicator will illuminate. 6. If the absence of voltage is not verified, the Caution Indicator will illuminate for about five seconds followed by a series of flashes. The number of flashes will help diagnose why the test failed. Refer to the Troubleshooting section for additional information. 	<p>3.</p> <p>5.</p> <p>6.</p>	

Troubleshooting



Warning:

- *Always de-energize power before accessing an electrical enclosure.*
- *Always follow safety and lockout/tagout procedures when working on or near electrical systems and equipment.*
- *Use proper personal protective equipment (PPE) when working around sources of hazardous electrical energy.*
- *Battery, AVT System Cable and O-rings can be replaced. No other part of the product is serviceable. Do not attempt to open the Indicator Module or Isolation Module for repair or modification. When servicing this product, only use specified replacement parts.*

The AVT checks for proper connection of the sensor and ground leads, verifies the battery voltage level is acceptable for proper operation and verifies that the tester is working properly with a series of self checks. If it fails any of these tests, it will indicate a failed test by illuminating the Caution Indicator for approximately 5 seconds. The AVT includes functionality to diagnose and communicate the reasons for test failure with flashing of the Caution Indicator. If the test fails, illumination of the Caution Indicator will be followed by a number of brief flashes ranging from 1-7. The number of flashes can be used to determine why the absence of voltage test failed.

Number of Flashes	Description	Recommended Actions
1	Battery voltage too low to run the test	Replace the battery and re-test.
2	Voltage detected above the threshold	<p>Warning: This indicates that the enclosure is energized.</p> <p>Follow safety procedures and use the appropriate PPE when investigating the source of voltage.</p> <p>If panel has a stored energy source, wait several minutes then re-test to see if energy has dissipated.</p>
4	Proper installation of the sensor leads could not be verified	<p>Warning: The enclosure may be energized.</p> <p>Follow safety procedures and use the appropriate PPE when verifying the enclosure is de-energized before performing additional troubleshooting.</p> <p>Refer to the Installation Instruction section and verify that the sensor leads are installed properly and that the device is grounded properly.</p>
3, 5, 6, or 7	Hardware failure	Contact Panduit Technical Support for additional troubleshooting.

If the Caution Indicator does not illuminate after pressing the Test Button:

1. Verify that the battery tray is fully engaged in the housing with the cap installed.
2. Replace the battery. If the battery voltage is too low, the Indicator Module will not operate.
3. Verify that the AVT System Cable is fully engaged in the connectors on the Indicator and Isolation Modules. The Indicator Module will not function if it is not connected to the Isolation Module.

Should a problem occur during installation, operation or maintenance of the VeriSafe AVT, contact Panduit using one of the technical support or customer service numbers listed on the cover of this manual. Contact Panduit if you have any product problems related to the safety function of the product. The product model number and serial number are printed on the Isolation Module and Indicator Module labels.

Maintenance



Warning:









- *The product uses a lithium battery that is a fire, explosion and severe burn hazard. Do not crush, recharge, disassemble or heat above 85 °C, incinerate, or expose contents to water.*
- *Battery, AVT System Cable and O-rings can be replaced. No other part of the product is serviceable. Do not attempt to open the Indicator Module or Isolation Module for repair or modification. When servicing this product, only use specified replacement parts.*
- *The AVT will not work with a standard alkaline 1.5Volt AA battery. Use only approved batteries listed in table shown in the Maintenance section of this instruction manual.*

Battery Replacement



Follow these steps to replace the battery. Table 1 provides a list of batteries approved for use with the AVT. Do not discard the battery in the trash; take it to an appropriate battery recycling facility.

Manufacturer	Model Number	Size	Description
Tadiran	TL-5903	AA, ER14505	3.6 Volt Lithium Battery
Xeno Energy	XLP-060F		
Saft	LS14500		

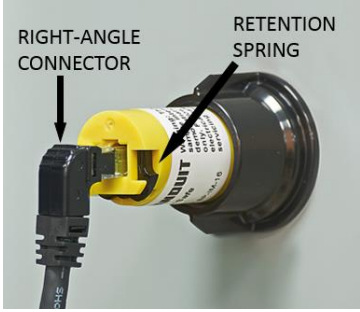

Table 1: Approved VeriSafe AVT batteries

 <p>1. Grip the Indicator Module Cap.</p>	 <p>2. Twist the Indicator Module cap counterclockwise approximately 90 degrees, until you feel a stop.</p>	 <p>3. Remove the cap.</p>	 <p>4. Grip the battery tray and slide it out until you feel a stop. The battery tray is not intended to be fully removed.</p>
 <p>5. Remove used battery. Dispose according to local procedures.</p> <p>Install a new battery. The positive terminal should face the operator.</p>	 <p>6. Slide the battery tray back in the housing.</p> <p>A self test is initiated when the battery tray is inserted and connection is made between the battery and AVT electronics.</p>	 <p>7. Replace the cap.</p>	 <p>8. Twist cap clockwise to lock into place. Record the date the battery was replaced in equipment documentation.</p>

AVT System Cable Removal

	 <ol style="list-style-type: none"> 1. Grip the Retention Spring on both sides. 2. Pull down on the Retention Spring approximately 1/16 inch [1.5 mm]. 	 <ol style="list-style-type: none"> 3. Continue holding the Retention Spring down while pulling back on the right-angle connector to release the AVT System Cable.
---	---	--

O-ring Replacement

 <p>Cap closure O-ring</p>	 <p>Sealing O-ring</p>
---	---

The O-rings can be replaced if they become dry or brittle. In critical sealing applications, such as wash down environments, it is recommended that the O-rings be replaced every 5 years. Apply a light coating of silicone grease to the O-rings to promote sealing and extend O-ring life.

Cleaning Instructions

The Indicator Module can be cleaned with a damp cloth or isopropyl alcohol based cleaner. Do not use abrasives or high alkaline cleaners. Do not leave cleaners on the device for a long period, rinse immediately. Do not apply cleaners in direct sunlight or elevated temperatures.

The section of the VeriSafe Indicator Module that is external to the electrical enclosure is approved for wash down as specified by NEMA 4 and IP66 standards. Before a wash down operation, ensure the O-rings are in good condition, the faceplate is not damaged and fully secured to the unit, and the cap is fully installed.

Visual Inspection

Periodically inspect the AVT and replace any damaged parts, cables or terminations. Inspect the Sensor Lead terminations to ensure they are tight, the leads are secure and do not show signs of damage. Inspect the AVT System Cable to ensure it is locked into place on both ends, is secure and does not show signs of damage. Inspect the Indicator Module to ensure O-rings are not dry or brittle and that the retaining nut and cap are in place. The procedure described in the Commissioning Checklist can be performed at any time.

Warranty

Panduit Limited Product Warranty

1. **Limited Product Warranty.** For purposes of this Limited Product Warranty, “**Panduit products**” mean all Panduit-branded products that Panduit sells. Unless a different time period is set forth in the Panduit product manual, user guide or other product documentation, Panduit warrants that the Panduit product, and each part or component of the Panduit product, will comply with Panduit’s published specifications and will be free from defects in material and workmanship for a period of 1 year from the date of invoice from Panduit or its authorized distributor, not to exceed 18 months from the original date of shipment from Panduit’s facility.

2. **Firmware.** Unless otherwise provided in a separate license agreement, and subject to the limitations for third-party products set forth below, Panduit warrants that any firmware contained in any Panduit products, when used with Panduit-specified hardware and when installed properly, will perform in accordance with the Panduit published specifications for a period of 1 year from the date of invoice from Panduit or its authorized distributor, not to exceed 18 months from the original date of shipment from Panduit’s facility. Any exceptions to this 1 year warranty period will be identified in the Panduit product manual, user guide or other product documentation. Panduit does not warrant that the operation of the firmware will be uninterrupted or error-free, or that the functions contained therein will meet or satisfy Buyer’s intended use or requirements. Any warranties, if any, that Panduit provides for any standalone software that Panduit sells will be stated in the applicable End User License Agreement.

3. **Remedies.** Panduit’s sole and exclusive obligation and Buyer’s exclusive remedy under this warranty is Panduit’s repair or replacement of the defective Panduit product. Panduit shall have sole discretion as to which of these remedies Panduit will provide to Buyer. Buyer requested on-site warranty service is not covered and will be at Buyer’s sole expense, unless authorized in writing by Panduit in advance of the commencement of the on-site warranty service. Panduit has the right to either examine the Panduit products where they are located or, in its sole discretion, issue shipping instructions for return of the product. Where applicable, Buyer must return the defective product, part or component, transportation prepaid to Panduit’s customer service department accompanied by Panduit’s Return Material Authorization. If Panduit confirms that there is a defect that is covered by this warranty, the repaired or replaced Panduit product will be warranted for the remainder of the warranty period applicable to the originally shipped Panduit product, or for a period of 90 days from the date of shipment to Buyer, whichever is longer.

4. **No Warranty for Third-Party Products.** Panduit makes no representations and disclaims all warranties of any kind, express or implied relative to any third-party product or services, including any third-party software or firmware, which may be incorporated into a Panduit product and/or resold or sublicensed by Panduit. To the extent any warranties extended to Panduit by the third-party manufacturer are transferable, Panduit will transfer such warranties to Buyer and any enforcement of such third-party warranties shall be between the Buyer and the third-party. Panduit does not warrant the compatibility of the Panduit products with the products of other manufacturers or Buyer’s application except to the extent expressly represented in Panduit’s published specifications or written quotation.

5. **Exclusions.** Before using, Buyer shall determine the suitability of the Panduit product for his intended use and Buyer assumes all risk and liability whatsoever in connection therewith. The warranties contained herein shall not apply to any Panduit products that have been subjected to misuse, neglect, improper storage, handling, installation or accidental damage or modified or altered by persons other than Panduit or persons authorized by Panduit. In addition, the firmware warranty does not cover any defects resulting from Buyer-supplied firmware or unauthorized interfacing, operation outside of the environmental specifications for the products, or improper or inadequate site preparation or maintenance by Buyer. Panduit products are not designed, intended or authorized to be used in medical applications or as components in medical devices that are used to sustain or support human life. Should Buyer purchase or use a Panduit product for any such unintended or unauthorized medical application, Buyer shall indemnify and hold Panduit harmless from any liability or damage whatsoever arising out of the use of Panduit products in such medical applications.

6. **LIMITATION ON LIABILITY. THE WARRANTIES PROVIDED HEREIN ARE BUYER’S SOLE AND EXCLUSIVE WARRANTIES. ALL IMPLIED WARRANTIES, INCLUDING WITHOUT LIMITATION THE IMPLIED WARRANTIES OF MERCHANTABILITY OR FITNESS FOR ANY PARTICULAR USE ARE DISCLAIMED. TO THE EXTENT PERMITTED BY LAW, IN NO EVENT SHALL PANDUIT BE LIABLE FOR ANY LOSS OR DAMAGES ARISING FROM ANY PANDUIT PRODUCT WHETHER DIRECT, INDIRECT, CONSEQUENTIAL, INCIDENTAL OR SPECIAL, INCLUDING WITHOUT LIMITATION ANY CLAIM FOR LOSS OF DATA, LOSS OF ACTUAL OR ANTICIPATED REVENUE, PROFITS OR SAVINGS.**

7. **General.** This Limited Product Warranty applies to the Panduit products only and not to any combination or assembly of the Panduit products. Nothing in this Limited Product Warranty shall be construed to provide Buyer with a warranty for any system implementation using Panduit products. The Panduit Certification Plus System Warranty is available for projects that are installed by Panduit Certified Installers, meet various requirements and are registered with Panduit in accordance with the terms of the Panduit Certification Plus System Warranty.