

i **NOTE**
 All numerical values are in U.S. customary units [with metric units in brackets]. Dimensions are in inches [and millimeters]. Unless otherwise specified, dimensions have a tolerance of ± 0.025 [± 0.64] and angles have a tolerance of $\pm 2^\circ$. Figures and illustrations are for identification only and are not drawn to scale.

1. INTRODUCTION

This specification covers the requirements for application of TE Connectivity (TE) HD30 series connector system. The HD30 is a metal version featuring quick connect-disconnect bayonet coupling, single hole bulkhead mounting, silicone seals and a rear insertion/rear removal contact system.

The HD30 Series is a heavy duty rated, environmentally sealed, metal shell, multi-pin connector. The metal shell is ideal in heavy duty equipment, transportation, construction and agriculture.

Basic terms and features of this product are provide in Figure 1 and 2 for standard and reverse configuration, respectively. HD30 Series are available in size 18 and 24. See Figure 3 for pin arrangements.

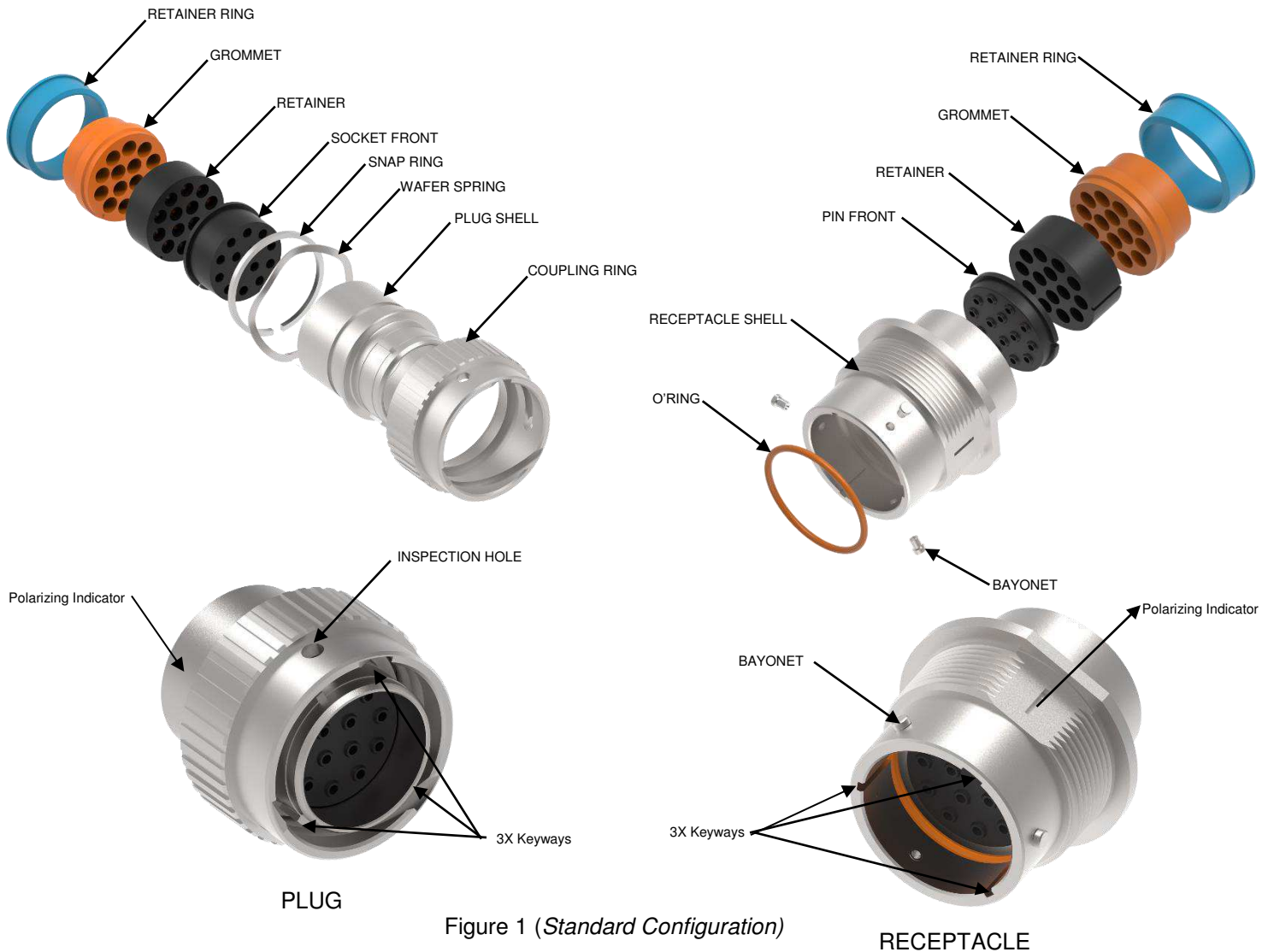

Figure 1 (Standard Configuration)

i **Note**
 The polarizing indicator is same color as shell.

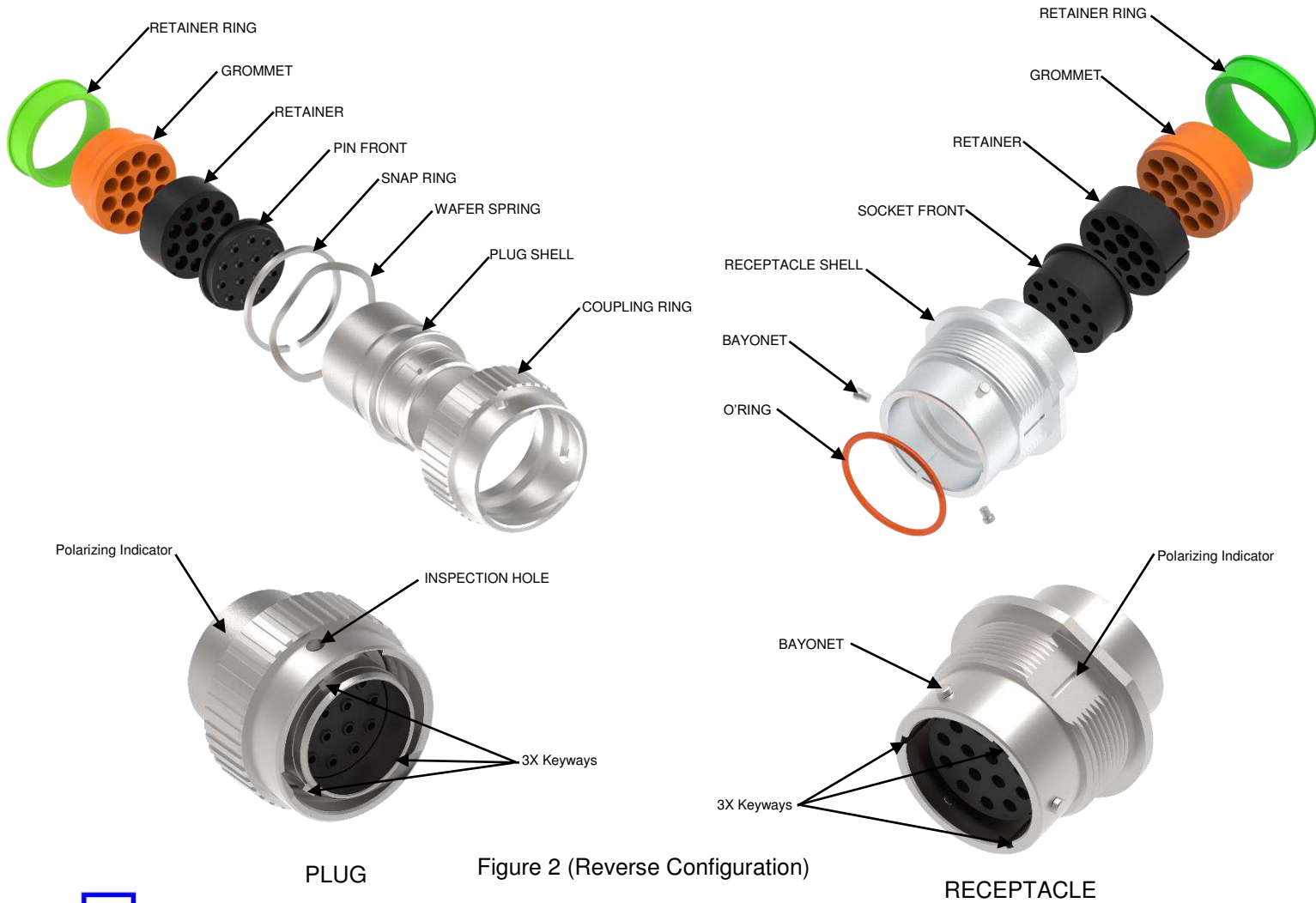
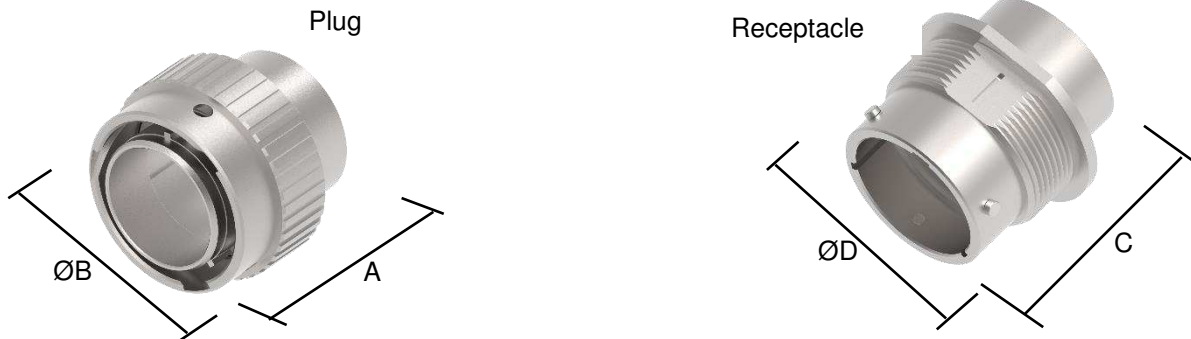

Figure 2 (Reverse Configuration)

i Note
The polarizing indicator is same color as shell.

1.1 Product Dimensions



Shell Size	Overall Length A	Overall Height ØB	Overall Length C	Overall Height ØD
18	1.521 [38.63]	1.700 [43.17]	1.648 [41.86]	1.750 [44.45]
24	1.521 [38.63]	1.950 [49.53]	1.648 [41.86]	2.000 [50.80]

2. REFERENCE MATERIAL

2.1 Revision Summary

See section 8

2.2 Customer Assistance

Reference Product Base Part Numbers, HD34-18-XXP/SX-XXXX, HD36-24-XXP/SX-XXXX, HD36-18-XXP/SX-XXXX, HD36-24-XXP/SX-XXXX. Where XX is pin arrangement, X is seal type (N,T,E), XXXX is modification code. Product Code J802 (Size 18) and EQ88 (Size 24) is representative of DEUTSCH HD30 series connector system. Use these number will identify the product line and help you obtain product and tooling information when visiting www.te.com or calling the number at the bottom of page 1.

2.3 Drawings

Customer drawings for product part numbers are available from www.te.com. Information contained in the customer drawing takes priority.

Product Drawing	Description
HD34-18-14P/SE-C020	Size 18 Receptacle
HD34-18-14P/SN-C020	Size 18 Receptacle
HD34-18-6P/SX-C030	Size 18 Receptacle
HD34-18-6PX	Size 18 Receptacle
HD34-18-6SX	Size 18 Receptacle
HD34-18-XXP/SX	Size 18 Receptacle
HD34-18-XXP/SX-059	Size 18 Receptacle
HD34-18-XXP/SX-072	Size 18 Receptacle
HD34-18-XXP/SX-L005	Size 18 Receptacle
HD3X-XX-XP/SX-L006	Size 18 Receptacle
HD34-24-14SN-C019	Size 24 Receptacle
HD34-24-19P/SE-C018	Size 24 Receptacle
HD34-24-19P/SN-C018	Size 24 Receptacle
HD34-24-31PT-BL07	Size 24 Receptacle
HD34-24-31PX-B019	Size 24 Receptacle
HD34-24-33PN-BN01	Size 24 Receptacle
HD34-24-34PN-BN01	Size 24 Receptacle
HD34-24-7P/SN-C038	Size 24 Receptacle
HD34-24-91PX-B019	Size 24 Receptacle
HD34-24-9PX-B019	Size 24 Receptacle
HD34-24-XXP/SX	Size 24 Receptacle
HD34-24-XXP/SX-059	Size 24 Receptacle
HD34-24-XXP/SX-072	Size 24 Receptacle
HD34-24-XXP/SX-L005	Size 24 Receptacle
HD34-24-XXP/SX-R010	Size 24 Receptacle
HD3X-XX-XP/SX-L006	Size 24 Receptacle

Product Drawing	Description
HD36-18-14P/SE-C020	Size 18 Plug
HD36-18-14P/SN-C020	Size 18 Plug
HD36-18-14SE-C021	Size 18 Plug
HD36-18-14SE-C022	Size 18 Plug
HD36-18-6P/SX-C030	Size 18 Plug
HD36-18-6PX	Size 18 Plug
HD36-18-6SX	Size 18 Plug
HD36-18-XXP/SX	Size 18 Plug
HD36-18-XXP/SX-059	Size 18 Plug
HD36-18-XXP/SX-072	Size 18 Plug
HD36-18-XXP/SX-L005	Size 18 Plug
HD3X-XX-XP/SX-L006	Size 18 Plug
HD36-24-14PE-C019	Size 24 Plug
HD36-24-197/SN-C018	Size 24 Plug
HD36-24-19P/SE-C018	Size 24 Plug
HD36-24-19P/SN-C018	Size 24 Plug
HD36-24-31SX-B019	Size 24 Plug
HD36-24-7P/SN-C038	Size 24 Plug
HD36-24-91SX	Size 24 Plug
HD36-24-91SX-B019	Size 24 Plug
HD36-24-91SX-P064	Size 24 Plug
HD36-24-91SX-P064-059	Size 24 Plug
HD36-24-91SX03	Size 24 Plug
HD36-24-91S_PL03	Size 24 Plug
HD36-24-9SX-B019	Size 24 Plug
HD36-24-XXP/SX	Size 24 Plug
HD36-24-XXP/SX-059	Size 24 Plug
HD36-24-XXP/SX-072	Size 24 Plug
HD36-24-XXP/SX-L005	Size 24 Plug
HD36-24-XXP/SX-L072	Size 24 Plug
HD3X-XX-XP/SX-L006	Size 24 Plug
HDB36-18-8P/SN	Size 18 Plug, Breakaway
HDB36-24-16P/SN	Size 24 Plug, Breakaway
HDB36-24-19P/SN	Size 24 Plug, Breakaway
HDB36-24-21P/SN	Size 24 Plug, Breakaway
HDB36-24-23P/SN	Size 24 Plug, Breakaway
HDB36-24-23P/SN-059	Size 24 Plug, Breakaway
HDB36-24-91S_059	Size 24 Plug, Breakaway
HDB36-24-91SX	Size 24 Plug, Breakaway
HDB36-24-91SX-059	Size 24 Plug, Breakaway
HDB36-24-XX-P/SX-059	Size 24 Plug, Breakaway
HDB36-XX-XXP/SX	Size 24 Plug, Breakaway
HDB36-XX-XXP/SX-059	Size 24 Plug, Breakaway

2.4 Specifications

108-151014	DEUTSCH HD30 Series Product Specification
108-151000	DEUTSCH S&F Contact Product Specification
108-151004	DEUTSCH Solid Contact Product Specification
114-151000	DEUTSCH Size 16 S&F Pin and Socket Application Specification
114-151001	DEUTSCH Size 16 S&F Pin and Socket Application Specification
114-151002	DEUTSCH Size 12 S&F Pin and Socket Application Specification
114-151003	DEUTSCH Size 20 S&F Pin and Socket Application Specification
114-151004	DEUTSCH Size 4-20 Solid Pin and Socket Application Specification
114-151006	DEUTSCH Size 12 S&F Pin and Socket Application Specification
0425-013-1800	Size 18 Arrangements
0425-014-2400	Size 24 Arrangements

2.5 Instructional Material

Instruction sheets (408-series) provide product assembly instructions or tooling setup, and operation procedures and customer manuals (409-series) provide machine setup and operating procedures. Instructional material that pertain to this product are:

408-151007	DEUTSCH Extraction Tools for Rear-Release Connectors
408-151066	DEUTSCH Sealing Plugs and Locking Keying Pins
408-151078	DEUTSCH Extended PCB Pins
408-151083	DEUTSCH Size 4 Crimp Sleeve Reducer

3. REQUIREMENTS

3.1. Safety

Do not stack product shipping containers so high that the containers buckle or deform.

3.2. Storage

A. Ultraviolet Light

Prolonged exposure to ultraviolet light may deteriorate the chemical composition used in the product material.

A. Shelf Life

The product should remain in the shipping containers until ready for use to prevent deformation to components. The product should be used on a first in, first out basis to avoid storage deterioration could adversely affect performance.

B. Chemical Exposure

Do not store product near any chemical listed below as they may cause stress corrosion cracking in the material.

Alkalis	Amines	Carbonates	Nitrites	Sulfur Nitrites	Tartrates
Acids	Ammonia	Citrates	Phosphates	Sulfur Compounds	



NOTE

Resistance depend on chemical concentration, temperature, and exposure medium.

3.3 Characteristics

A. Part Numbering system

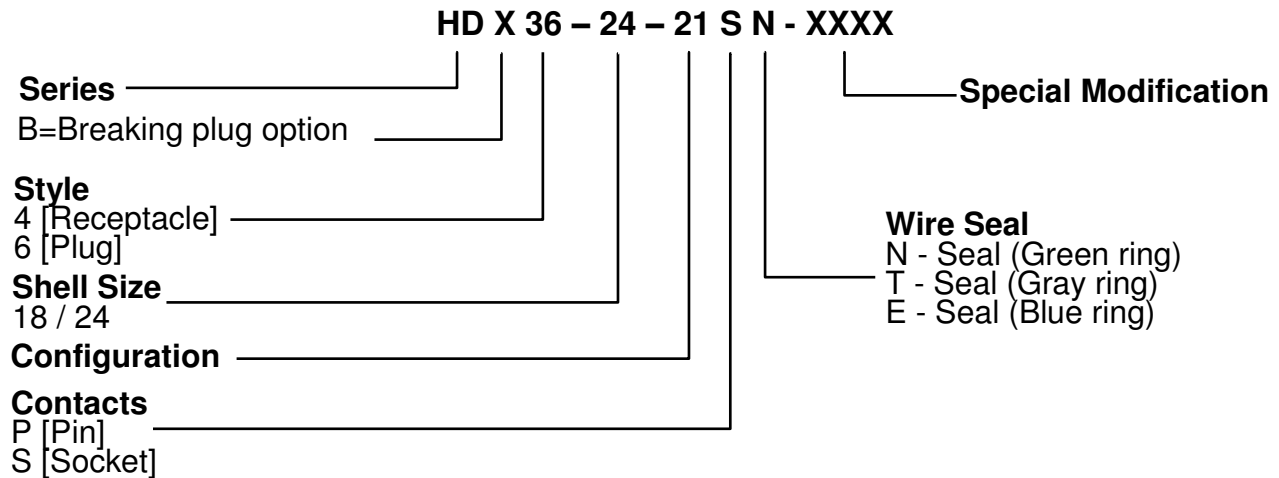

B. Pin Arrangements

Size 18 (See 0425-013-1800 for contact cavity marking)

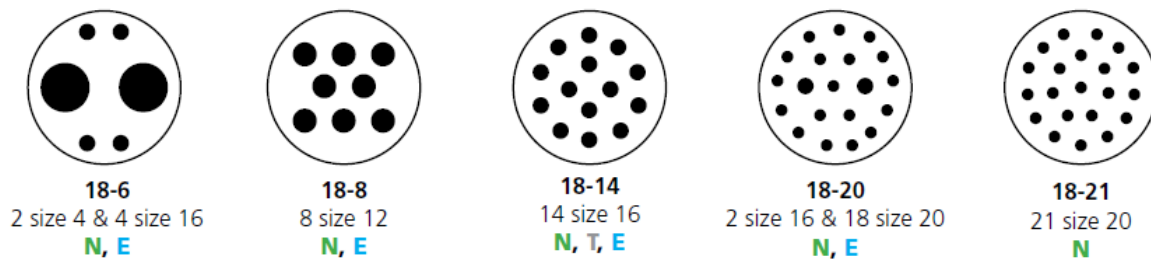

Size 24 (See 0425-014-2400 for contact cavity marking)

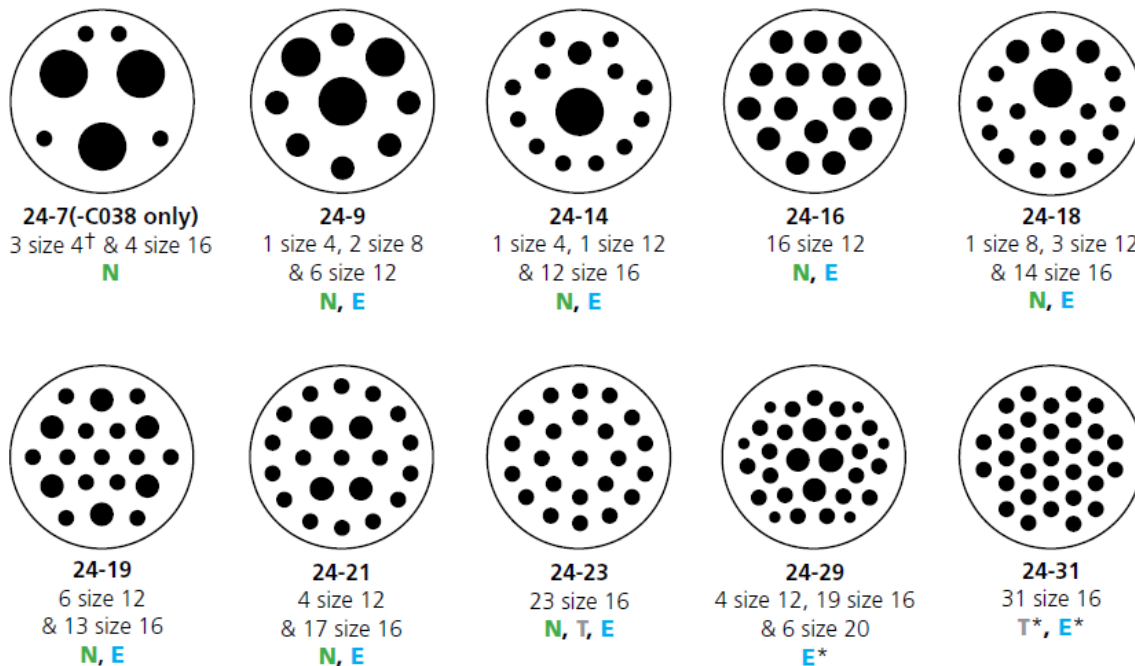

†Requires size 4 contact part number, 5960-203-04**(Pin) and 5962-203-04**(Socket).

*Modified seal see drawing.

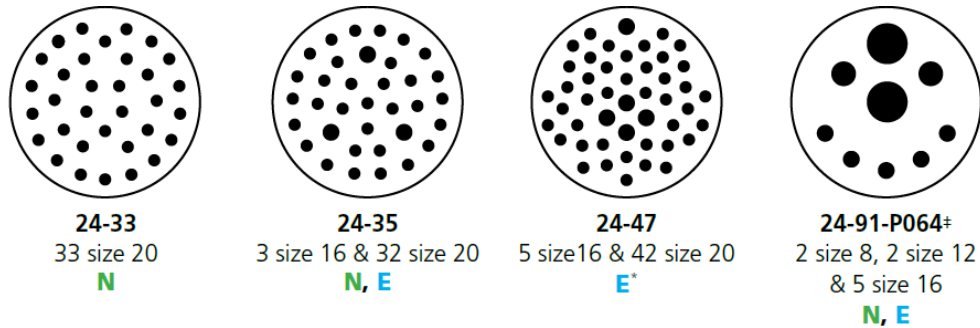

‡Without P064 modification, plug cavities 4 and 5 are internally connected.

Figure 3 Pin Arrangements

C. Materials

Retainer Ring: PA66 10GF (Green, Gray, Blue)
 Grommet: VMQ (Burnt-Orange)
 Contact Retainer: PEI (Black)
 Snap Ring: Steel
 Socket Front: PEI (Black)
 Pin Front: TPE (Black)
 Plug Shell: Aluminum, Wax
 Receptacle Shell: Aluminum, Wax
 Wafer Spring: Steel
 Coupling Ring: Aluminum, Wax

D. Sealing Range

Contact Size	N-Seal Green Ring	T-Seal Gray Ring	T-Seal Modified*	E-Seal Blue Ring	E-Seal Modified*
20 14-22 AWG [2.5-0.35mm ²]	.040-.095 [1.02-2.41]	.040-.095 [1.02-2.41]	-	.040-.095 [1.02-2.41]	.040-.083 [1.01-2.10]
16 14-20 AWG [2.0-0.5mm ²]	.100-.134 [2.54-3.40]	.088-.134 [2.23-3.40]	.088-.106 [2.24-2.69]	.053-.120 [1.35-3.05]	.053-.103 [1.35-2.62]
12 10-14 AWG [6.0-2.0mm ²]	.134-.170 [3.40-4.32]	.113-.170 [2.87-4.32]	-	.097-.158 [2.46-4.01]	.097-.158 [2.46-4.01]
8 8-10 AWG [10.0-5.0mm ²]	.190-.240 [4.83-6.10]	.170-.240 [4.32-6.10]	-	.135-.220 [3.43-5.59]	-
4 6 AWG [16.0-13.0mm ²]	.280-.292 [7.11-7.42]	.261-.292 [6.63-7.42]	-	.261-.292 [6.63-7.42]	-
4 4 AWG [25.0-21.0mm ²]	.311-.420 [7.90-10.67]	-	-	-	-

*Arrangements 24-29, 24-47 and 24-31 are only available with modified seals.
 Arrangement 24-31 modified E-Seal= 0.053 – 0.106 [1.35 – 2.69]

Green: N-Seal
Gray: T-Seal
Blue: E-Seal

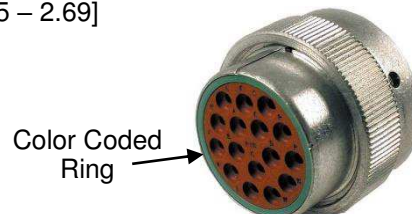

E. Sealing Plugs

Open cavities provide pathways for contaminants to enter the connectors. To maintain seal integrity, any unused cavity must be filled with the appropriate size sealing plug. See [408-151066](#) for instructions.

Part Number	Contact Size	Material	Color	Description	Sealing Plug
114019	4	VMQ	Red-Orange		
114018	8	PBT	White		
114017	12, 16	PBT	White		
0413-217-1605	16	PBT	White	Locking	
0413-003-1605	16	PBT	Blue		
0413-204-2005	20	PBT	Red		

F. Keying Pins.

Keying pins are solid plastic rods used to help prevent mis-mating of like connectors in close proximity. Keying pins are inserted into the retention fingers of an empty socket cavity. Once installed, the keying pin blocks a mating contact pin from being inserted. The contact pin will be blocked before the coupling device mates the connectors, helping to prevent the mis-mating of like connectors. Proper usage requires that the corresponding mating pin be omitted, and a sealing plug inserted in the rear cavity of the mating connector. Individual applications will vary, and testing should be done to determine the best pattern arrangement to help prevent improper connector mating. See [408-151066](#) for instructions.

Part Number	Contact Size	Material	Color	Description	Sealing Plug
0413-216-2005	20	PBT	Red	Keying	
0413-215-1605	16	PBT	White		
0413-214-1205	12	PBT	Yellow		



Note:
Multiple keying pins may be required to help prevent unintentional forced mating.

G. Modifications / Breakaway

Mod	Description
059	Threaded Adapter with drain hole and Cable Clamp Assy
072	Threaded Adapter only with drain hole
B019	Custom snap ring mount
BL07	Custom snap ring mount, special adapter ring
C018	Cavities blocked (11,18, 19), N/E seal option
C019	Cavities blocked (1, 2, 8, 9), N/E seal option
C020	Cavities blocked (A, D), N/E seal option
C021	Cavities blocked (A, B, C, D)
C022	Cavities blocked (A, D, J, M), with reduced diameter seals (E seal)
C030	4 size 16 cavities blocked (1, 2,5, 6)
C038	3 size 4, 4size 16, special size 4 AWG contact
L005	Threaded Adapter only without drain hole
L006	Threaded Adapter without drain hole and Cable Clamp Assy
P064	24-91 arrangement without internal jumper
PL03	Cable Clamp Adapter, 24-91 arrangement without internal jumper
R010	Special flange for 0413-001-2406 o-ring

The 059 / L006 and 072 / L005 threaded adapter and cable clamp provide positive support to the wire bundle while reducing strain on the connector. The threaded adapter is available with or without drain holes for plug and receptacle.



059
Threaded Adapter
Cable Clamp Assy
With Drain Holes

L006
Threaded Adapter
Cable Clamp Assy
Without Drain Holes



072
Threaded Adapter
With Drain Holes

L005
Threaded Adapter
Without Drain Holes

C030 Modification

Size 18, 2 pin connector that accept size 4 solid contacts rated up to 100 amps for each cavity.



HDB - Breakaway Plug

The HDB is designed to provide an emergency disconnect between farm tractors and implements that require power connections. The HDB breakaway plug is designed to break the connection before damaging the wiring system. These plugs can be specified with pin or socket contacts and connect only with the HD30 Series receptacles. As an added design convenience, the HDB is also available with an optional cable clamp (059 mod). Breakaway function occurs at an axial load of 50-100 lbf [222-445 N].



H. Mounting Hardware

DEUTSCH lockwashers and panel nuts are available to aid in mounting the HD30 Series connectors. The lockwashers are used to add tension between the threads and the nut to provide a secure mount. The lockwasher and the panel nut should be used together.

LOCKWASHER

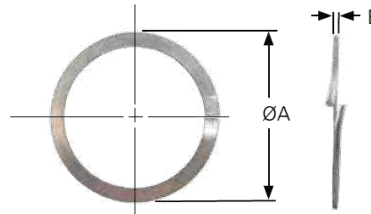

Shell Size	Part Number	ØA	B
18	114021	1.699[43.15]	.062[1.57]
24	112264	1.887[47.93]	.062[1.57]

Material: Stainless Steel
 Operating temperature is -55°C to +125°C [-67° to +257°F].

PANEL NUT

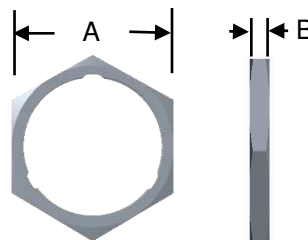

Shell Size	Part Number	A	B
18	114020-90	1.685 [42.80]	.178 [4.52]
24	112263-90	1.875 [47.63]	.178 [4.52]

Material: Aluminum, Wax
 Operating temperature is -55°C to +125°C [-67° to +257°F].

I. Mounting

RECEPTACLE MOUNTING

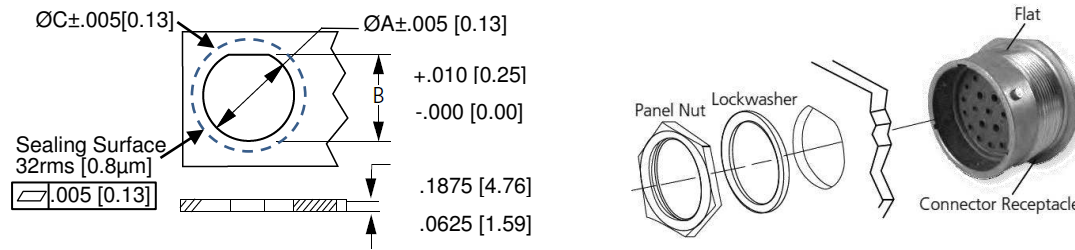

Shell Size	ØA	B	ØC
18	1.507 [38.28]	1.442 [36.63]	1.75 [44.45]
24	1.696 [43.08]	1.632 [41.45]	2.00 [50.80]

D-HOLE PUNCH

The D-hole punch is a hand tool used to cut a D-shaped hole. The D-shaped hole allows the connector to be securely mounted and prevents the connector from spinning.



Punchable Material:
Up to .078" mild steel or aluminum. Up to .1875" plastic, wood, paneling, or other soft material.

Tool Material:
A2 material heat treated to a Rockwell hardness of 60 to 62.

Tool Size: (rough dimensions)
5.5"L x 2"H x 2" D

Sharpening:
The tool can be sharpened as needed.

Usability:
A .625" minimum pilot hole is required to accommodate the draw stud. Air tools can be used.

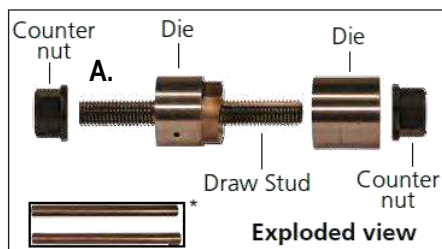

The rods included with the "D" hole punch are used to remove the cutout and are not used in the cutting process.

Shell Size	Part Number
18	18-D-PUNCH
24	24-D-PUNCH

J. Accessories

Several accessory items can be used to complement the connectors such as PVC boots, metal strain relief, neoprene closed cell gaskets, and metal protective dust cap. Accessories are designed to complete the application and meet a wide array of design requirements such as solutions for mounting, providing additional protection, and offering increased aesthetics.

BOOTS

Slip-on boots are not only aesthetically appealing, but also provide increased protection from dirt, paint overspray, and pressure washing.



Part Number	Description
HD30-18BT	18 shell size boot, gray
HD30-18BT-BK	18 shell size boot, black
HD30-18BT-90-BK	18 shell size boot, 90° bend, black
LC-90BT-HT	18 shell size boot, 90° bend, high temperature material, yellow
HD30-24BT	24 shell size boot, gray
HD30-24BT-BK	24 shell size boot, black
HD30-24BT-90-BK	24 shell size boot, 90° bend, black
MT-90BT-HT-24	24 shell size boot, 90° bend, high temperature material, yellow

Material: PVC
 Operating Temperature: -29° to +100°C [-20° to +212°F].

PROTECTIVE DUST CAPS

Protective caps are available for plugs and receptacles. They come with or without the lanyard chain. The dust caps offer an easy and economical solution to protect plugs and receptacles from physical damage and environmental conditions. The caps attach securely to protect the contact surfaces when disconnected from the appropriate connector. The cap's design is environmentally sealed and validate to IP67 and IP6K9K.



Shell Size	Part Number	Lanyard Chain	Used On
18	HDC36-18	Yes	Receptacle
	HDC36-18-1E	No	
24	HDC36-24	Yes	
	HDC36-24-1E	No	
18	HDC34-18	Yes	Plug
	HDC34-18-1E	No	
24	HDC34-24	Yes	
	HDC34-24-1E	No	

Material:
 Cap: Aluminum, Wax
 Lanyard Chain: Stainless Steel
 Operating Temperature: -55° to +125°C [-67° to +257°F]

STRAIN RELIEF



Shell Size	Orientation	Part Number
18	Straight	WHDS-18-1
24		WHDS-24-1
18	90°	WHDS-18-2
24		WHDS-24-2

Material

Strain Relied: Steel, Tin (may discolor)

Screw/Nut: Stainless Steel

Operating Temperature: -55° to +125°C [-67° to +257°F]

GASKETS

Moisture, dirt, salt, sand, and road debris can all work their way into electrical panels through unsealed mounting flanges. These rugged high quality gaskets form a tight seal between the panel face and connector flange to help keep out destructive elements. The gaskets have a thickness of .125.



Shell Size	Part Number
18	16-04978
20	16-04477

Material: Closed Cell Sponge, Black

Operating temperature: -57° to +107°C [-70° to +225°F].

CABLE CLAMP WITH BUSHING

Provides support and strain relief to the wire bundle where it exits the rear of the connector. Threads onto either plug or receptacles with 072 or L005 threaded adapter modifications. Size 18 comes with single neoprene bushing. Size 24 comes with both size 18 and 24 bushings.



Shell Size	Part Number
18	0409-201-1800
24	0409-201-2400

Material

Clamp: Aluminum, Tin (may discolor)

Bushing: Neoprene, Black



Operating Temperature: -55° to +125°C [-67° to +257°F]

- Bushing no UV certificate, UV exposure not recommended.

CRIMP SLEEVE REDUCER

A crimp sleeve reducer allows DEUTSCH size 4 solid contacts to accept 8-10 AWG wire. When populating a connector using a contact with a reducer sleeve, be sure the insert seal penetrates the rear grommet. The use of the crimp sleeve reducer requires no extra crimp tools and provides an easy transition and increased flexibility. Used on pin arrangements with size 4 contact cavity. See [408-151083](#) for instructions.



Part Number	Description	Material	Image
0410-241-0406	Insert Seal	VMQ Red-Orange	
0421-203-04141	Crimp Sleeve Reducer	Copper Alloy Nickel	

EXTENDED PCB PINS

Straight reduced diameter extended pins are available for installation in the DEUTSCH family of connectors. The use of removable contacts provides design flexibility and a low cost alternative to meet application needs. These solid copper alloy pins may be specified in various plating's. See [408-151078](#) for instructions.

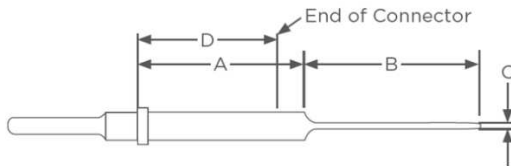

Contact Size	Part Number	A	B	C
20	0460-208-2031	1.305	.248	.025
	0460-208-2090	[33.15]	[6.30]	[.64]
16	0460-208-16141	1.300	.248	.025
	0460-208-1631	[33.02]	[6.30]	[.64]
	0460-241-16141	1.305	.160	.040
	0460-244-16141	.976	.400	.041
	0460-244-1631	[24.79]	[10.16]	[1.04]
12	0460-208-12141	1.305	.248	.025
	0460-245-1231	1.024	.500	.041
	0460-245-1290	[26.01]	[12.70]	[1.04]



3.4 Contact Insertion

- The crimped contacts must meet these specifications:
 - [114-151000](#) DEUTSCH Size 16 S&F Pin and Socket Application Specification
 - [114-151001](#) DEUTSCH Size 16 S&F Pin and Socket Application Specification
 - [114-151002](#) DEUTSCH Size 12 S&F Pin and Socket Application Specification
 - [114-151003](#) DEUTSCH Size 20 S&F Pin and Socket Application Specification
 - [114-151004](#) DEUTSCH Size 4-20 Solid Pin and Socket Application Specification
 - [114-151006](#) DEUTSCH Size 12 S&F Pin and Socket Application Specification

- Ensure the correct connector configuration is being used before inserting contacts.
 Standard Configuration: Pins used in receptacle; Sockets used in plug.
 Reverse Configuration: Sockets used in receptacle; Pins used in plug.



- Push contacts straight into the grommet until a positive stop is felt. The contact will lock into place. A slight tug on wire will confirm that it is properly locked in place.

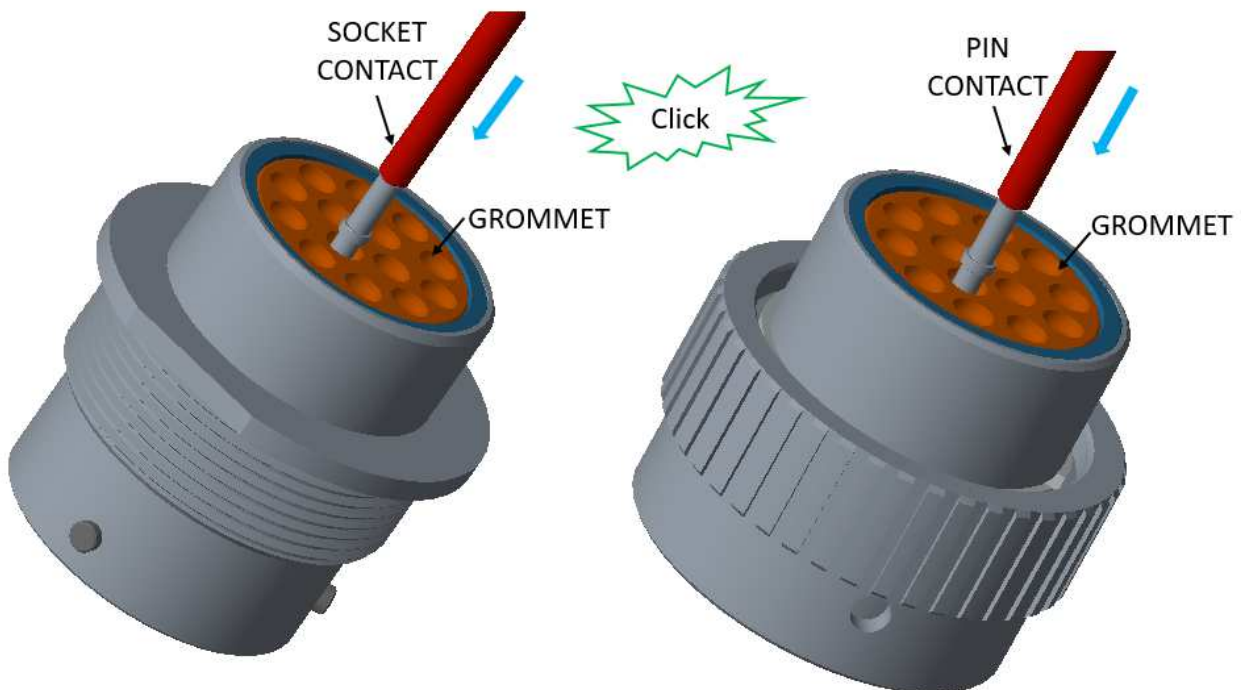

Note



- Wire insulation outside diameter must meet connector wire sealing range per section 3.3.D.
- Insertion tool, [M15570-16](#) (size 16) or [M15570-20](#) (size 20) may be needed for ≤ 20 AWG wire.

3.5 Contact Insertion Tool

Insertion tools are used to help insert small gage wired contacts into connectors that utilize a round shoulder contact retention system. Insertion tools are compact, easy-to-use and made with durable plastic to insert wired contacts without damage to wire, insulation, rear grommet seal or connector housing.

1. USING THE TOOL

1. Insert the wired contact into the colored end wire entry slot and gently pull back until the contact locking shoulder is against tool.
2. Push the tool/wired contact assembly into the connector rear until the contact is felt snap into position within the retainer.
3. While holding the wire forward, gently pull remove tool out.
4. A slight tug on wire will confirm the contact is properly locked in place.

Contact Size	Part Number	Mil-Spec	Color Insertion	Insertion Tool
16	M15570-16	M81969/14-03	Blue	
20	M15570-20	M081969/14-11	Red	



CAUTION

Do not twist or insert the insertion tool at an angle; otherwise, damage to the cavity retention finger(s) will result.

3.6 Contact Removal

DEUTSCH removal tools are designed to simplify contact removal and field service repair in connectors that utilize a round shoulder contact retention system. Removal tools are compact, easy-to-use, and manufactured of heavy duty plastic to remove contacts without damage to the wire, insulation, connector seals, or connector body.

Each extraction tool is designed to extract individual DEUTSCH solid and stamped and formed (S&F) pin and socket contacts from rear-release connectors. See [408-151007](#) for instructions.

1. USING THE TOOL

1. From the rear of the connector, align the tool tip with the contact cavity of the contact to be removed. Place the wire of the contact over the tool wire entry slot and apply light pressure on the wire until it enters the wire entry slot. See Figure 6, Detail A.
2. Slide the tool along the wire and into the contact cavity until the tool tip engages the contact and resistance is felt. See Figure 6, Detail A.
3. Gently pull the tool with the wire until the contact is removed. See Figure 6, Detail B.

Detail A

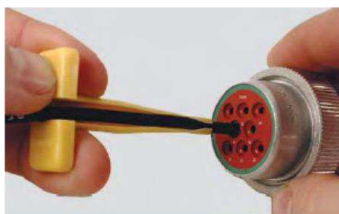

Detail B

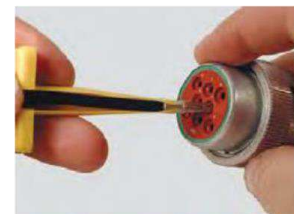

CAUTION

Do not twist or insert the extraction tool at an angle; otherwise, damage to the cavity retention finger(s) will result.



Part Number	Contact Size	Wire Gauge Range	Color
0411-027-0405	Size 4	4 AWG	Black
114009	Size 4	6 AWG	White
114008	Size 8	8-10 AWG	Green
0411-353-0805	Size 8 for HD Box	8-10 AWG	Green Extended
114010	Size 12	12 AWG	Yellow
0411-337-1205	Size 12	12 AWG Extra Thin Wall (E-Seal)	Orange
0411-291-1405	Size 16	14-16 AWG	Green
0411-310-1605	Size 16	16-20 AWG	Light Blue
0411-336-1605	Size 16	16-20 AWG Extra Thin Wall (E-Seal)	Dark Blue
0411-240-2005	Size 20	20-22 AWG	Red

3.7 Sealing Plug, Locking Sealing Plug and Keying Pin Installation

Sealing Plug Installation ([408-151066](#))

Step 1:

Holding the sealing plug with large diameter end away from the connector, gently apply downward pressure to force the sealing plug into the cavity.

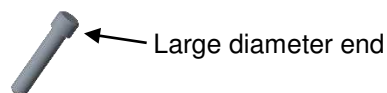

Step 2:

With perpendicular motion, apply downward pressure to the large diameter end of the sealing plug.

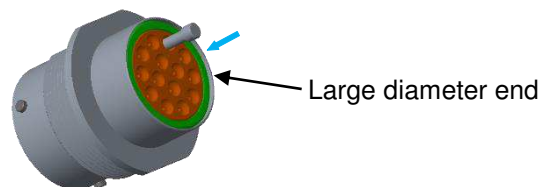

Step 3:

Apply pressure until sealing plug is forced to stop by contact with rear grommet. Visually inspect the sealing plug to confirm it is flush with cavity opening.



Locking Sealing Plug Installation (408-151066)

Step 1:

Holding the sealing plug with locking shoulder end towards the connector, gently apply downward pressure to force the sealing plug into the cavity.

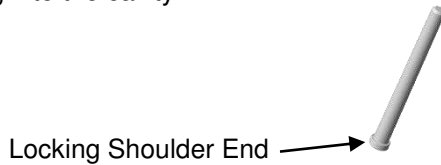

Step 2:

With perpendicular motion, apply downward pressure to the small diameter end of the sealing plug.

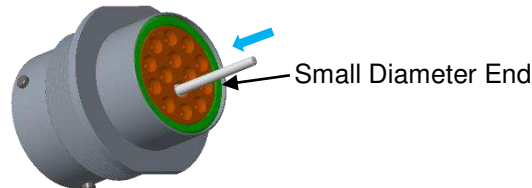

Step 3:

Apply pressure until sealing plug locks into place. A slight tug on the sealing plug will confirm it is locked into place.

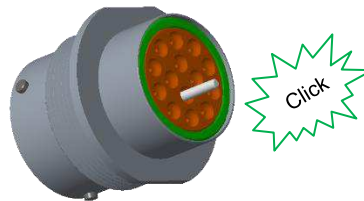

Keying Pin Installation (408-151066)

Step 1:

Holding the keying pin with large diameter end towards the connector, gently apply downward pressure to force the sealing plug into the cavity.

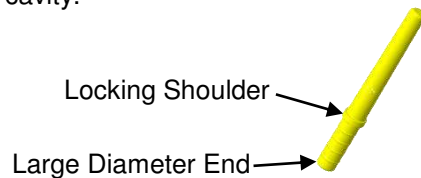

Step 2:

With perpendicular motion, apply downward pressure to the small diameter end of the sealing plug.

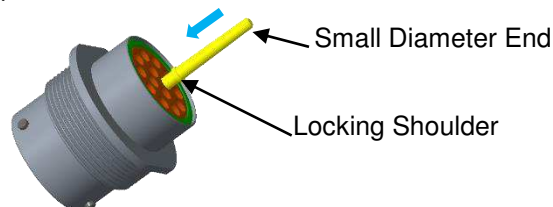

Step 3:

Apply pressure until keying pin locks into place. A slight tug on the sealing plug will confirm it is locked into place.

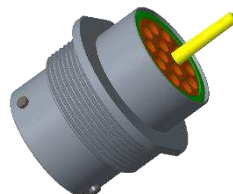

3.8. Connector Mating

To mate the plug and receptacle, the plug keys and receptacle keyways must align as shown in figure. Once aligned, it is pushed until it reaches the inner base of the connector and the Coupling Ring is screwed until the guides are observed through the holes in the Coupling Ring.

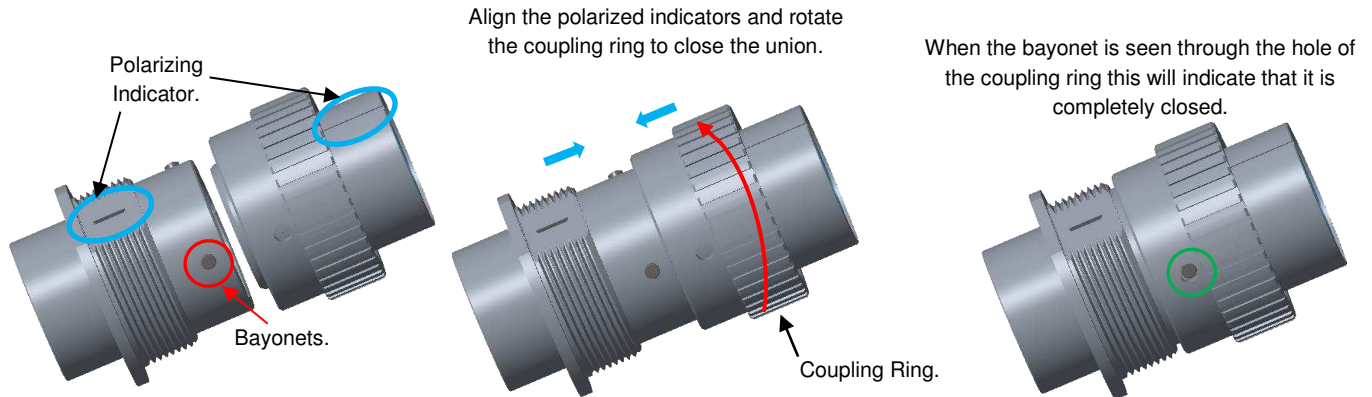

Polarized indicators serve as guides to make the connection between the connectors, each connector has an internal guide that makes the holes of the cavities are aligned but these are not visible to the naked eye, so the polarized indicators help us connect the connectors in better shape.



Note

It is not recommended to use dielectric grease on either plug or receptacle. The HD30 connectors are guaranteed to seal and perform per 108-151014 product performance without the application of grease or other foreign substance.

3.9. Connector Unmating

1. To uncouple the HD30 connector, turn coupling ring counterclockwise. This will unlock the lock and allow them to separate.

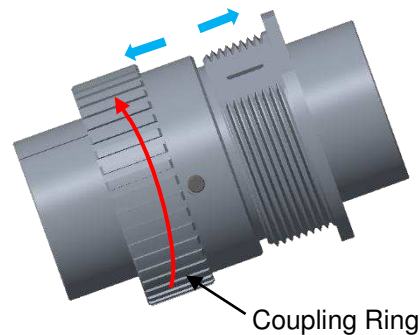

2. To separate the connectors, uncouple the Coupling Ring counterclockwise to unmate, follow the connector as indicated by the arrows.

3.10. Strain Relief, Boot, Gasket, Protective Dust Cap Installation and Removal

See section J for part numbers.

STRAIN RELIEF

1. Before installing strain relief onto the connector, first pry open the screw tabs a little to open up. Screw and nut are not assembled.

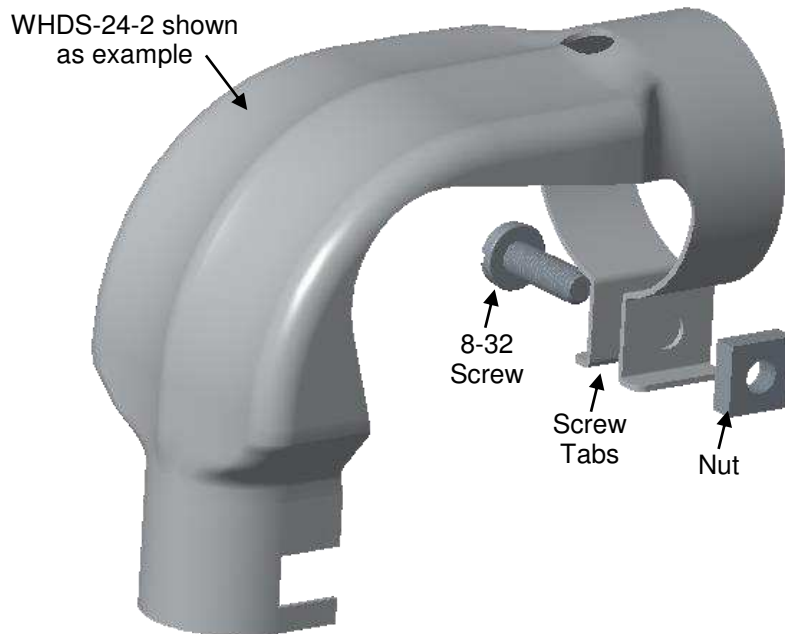

2. Install strain relief onto rear of connector. Attach screw and nut. Torque to 7-10 in-lbf [0.79-1.13 NM].

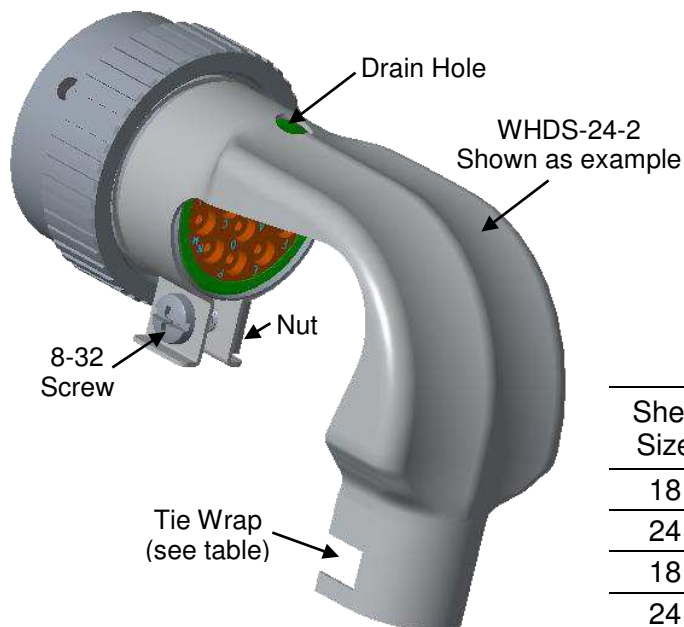

Shell Size	Orientation	Part Number	Tie Wrap Slot Width
18	Straight	WHDS-18-1	.250 [6.35]
24		WHDS-24-1	.275 [6.98]
18	90°	WHDS-18-2	.275 [6.98]
24		WHDS-24-2	.310 [7.87]

3. Install tie wrap.



Note

Strain relief can be mounted any angle. A drain hole is provided when pointing upward.

4. To remove the strain relief, first cut tie wrap off, if needed. Unscrew the screw and nut, then remove from screw tab. Next, pry open screw tabs a little and remove from connector.

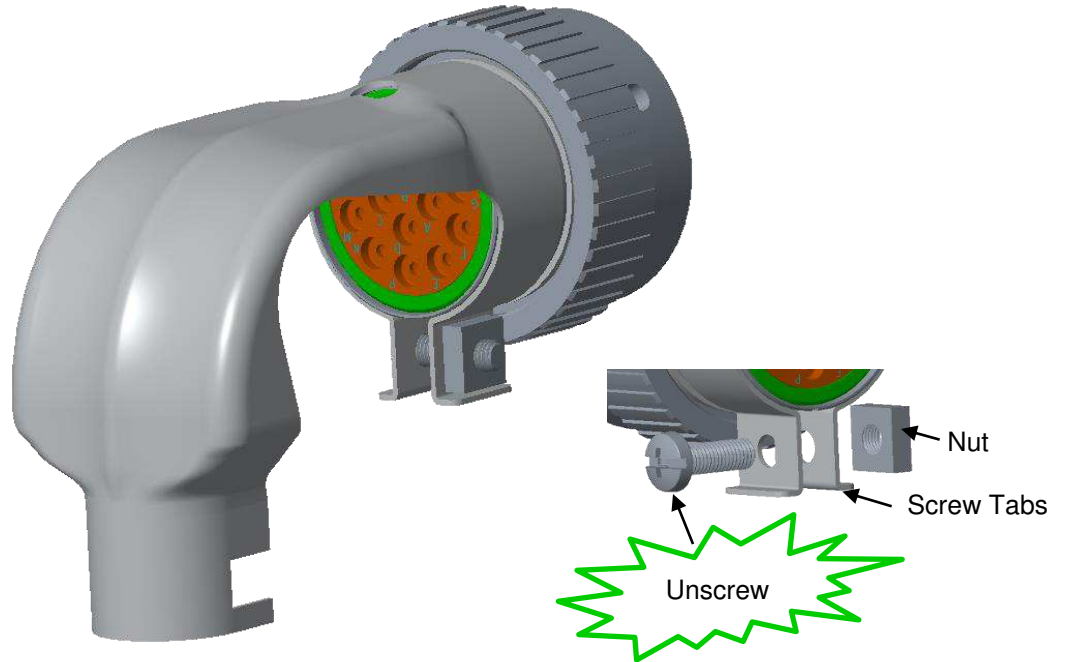

CABLE CLAMP WITH BUSHING

1. First insert the wires into the connector. Next pass the wires through the cable clamp and bushing then screw onto the threaded adapter and hand tight. Lastly, tighten the cable clamp screws to 17 In-Lbf [1.92 NM] maximum.

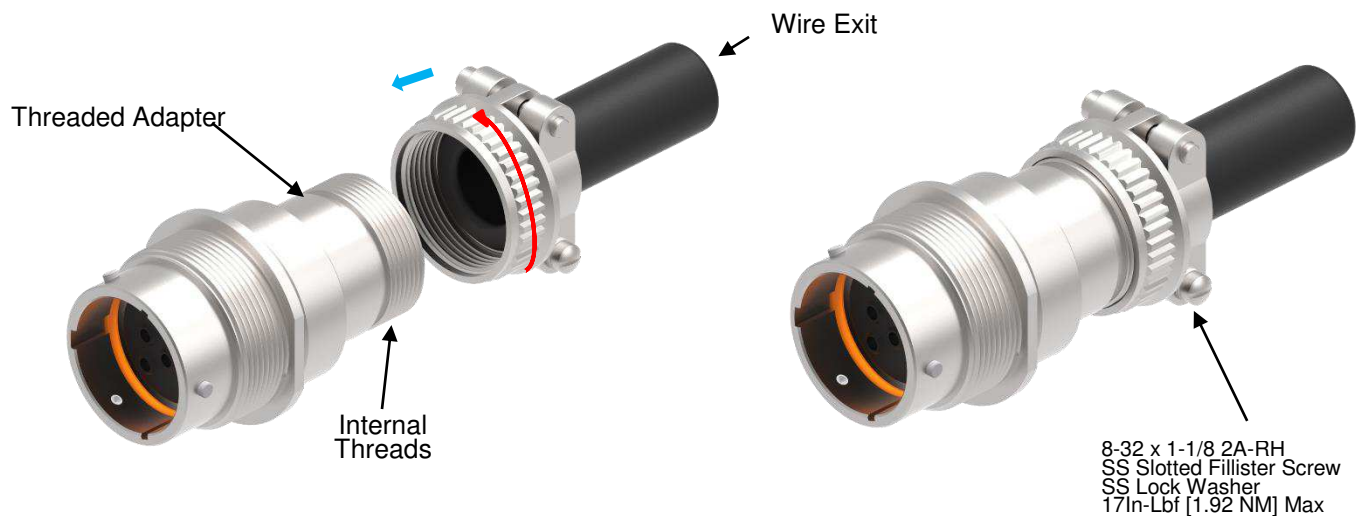

BOOT

First insert the wires into the connector. Next, cut off the end of the boot as needed then pass through the wires through the boot. Slide the boot onto the connector. If needed, attach a tie wrap on the end of the connector and boot. Trim tie wrap as needed.

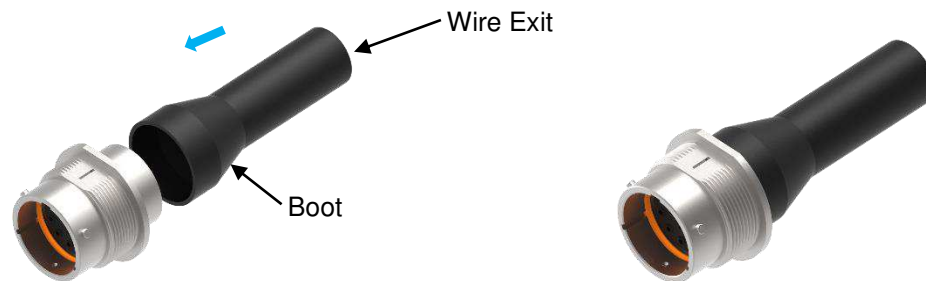

GASKET

Install the gasket onto the connector in front of the flange. Next install into panel mounting hole. See section 3.9 for panel installation.



PROTECTIVE DUST CAP

To mate the protective cap to the receptacle, align the bayonets on the receptacle to the openings on the cap. Turn clockwise until a snap is felt. Remove in reverse steps.



3.11. Panel Installation

1. The receptacles may be mounted to a panel, See Section 3.3 for panel cutout requirement. A clocking feature on the housing may be used to orient the connector on the panel, but the panel cutout must contain the proper tab in order to properly utilize this feature. If a gasket is used, ensure the gasket is installed onto the housing before inserting mating side through the panel cutout.

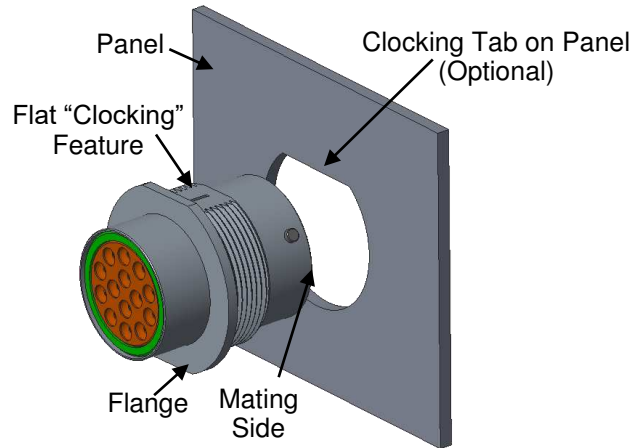

2. Install Lock Washer and Panel Nut. Secure the receptacle to the panel using the recommended mounting torque.

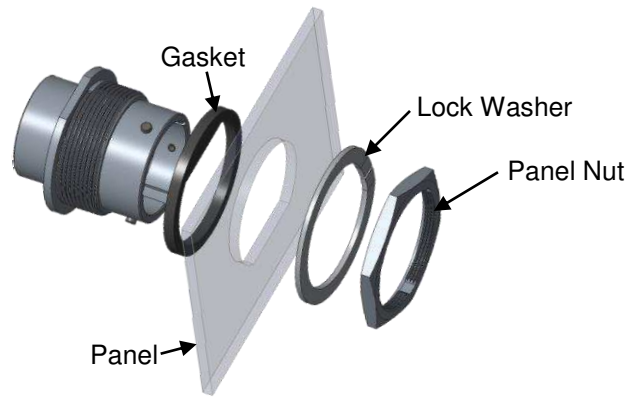

Panel Nut Mounting Torque			
Shell size	Mounting torque	Socket Size	Tool Speed Max
18	260-280 IN-LB. [29.4-31.6 NM]	1-11/16"	5 RPM
24	350-375 IN-LB. [39.5-42.6 NM]	1-7/8"	

i Note:
Do not cross thread panel nut or over torque panel nut

3.12. Replacement and Repair

Damaged or defective connectors must not be used. These connectors cannot be repaired.

4. QUALIFICATION

Refer to product specification [108-151014](#) for qualification and approved agency.

5. TOOLING

Refer to the following application specifications for reference on all pins and sockets contact termination tooling

114-151000	DEUTSCH Size 16 S&F Pin and Socket Application Specification
114-151001	DEUTSCH Size 16 S&F Pin and Socket Application Specification
114-151002	DEUTSCH Size 12 S&F Pin and Socket Application Specification
114-151003	DEUTSCH Size 20 S&F Pin and Socket Application Specification
114-151004	DEUTSCH Size 4-20 Solid Pin and Socket Application Specification
114-151006	DEUTSCH Size 12 S&F Pin and Socket Application Specification

6. HELPFUL HINTS

Helpful hint

Proper wire outside diameters help provide water tight seals.

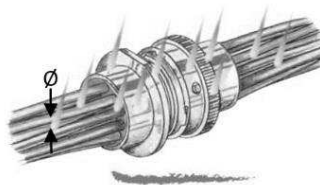

Helpful hint

Proper wire routing assures water tight seal performance

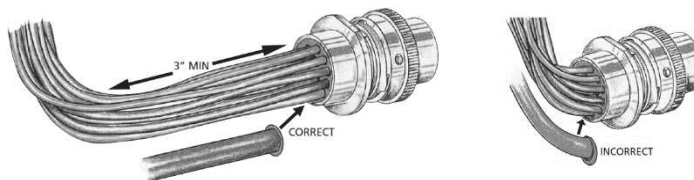

Helpful hint

Making the socket contact side the “hot side” can reduce the danger of electric shock.

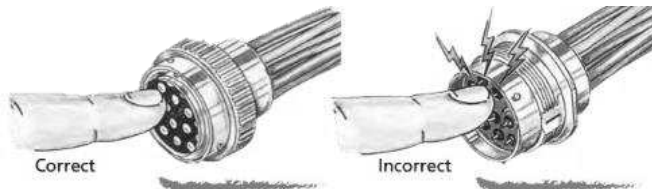

Helpful hint

Pulling lightly on the wire after it is snapped in place will assure the contact is locked.

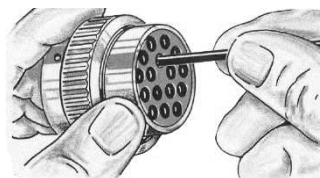

Helpful hint

Sealing plugs are used to seal the connector when all the cavities are not used by wires.

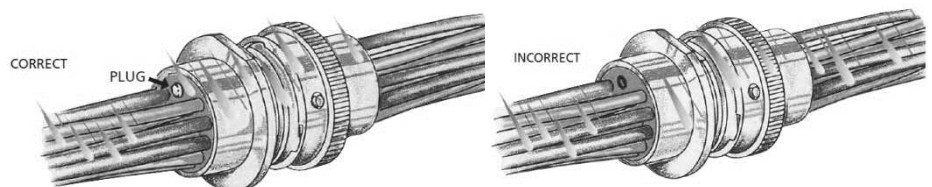

Helpful hint

Mounting connectors horizontally allows proper water drainage.

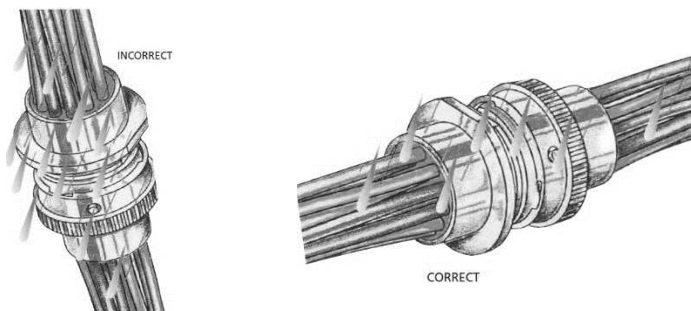

Helpful hint

Planned wire routing and clamp points can reduce harness cost by eliminating strain reliefs.

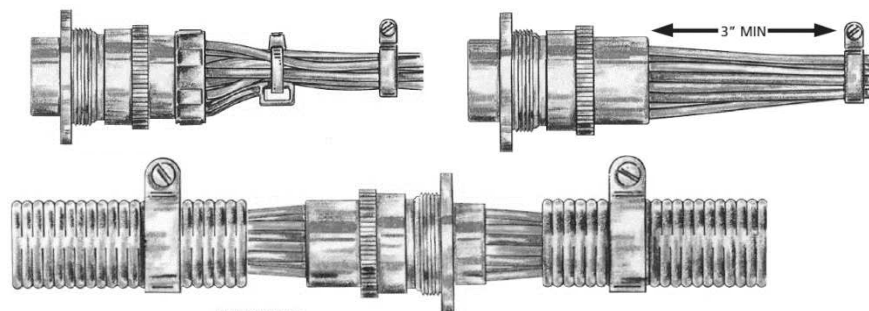

Helpful hint

Attaching the connector to a structure eliminates straining the electrical system in service.

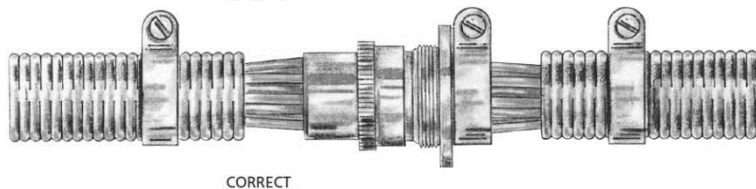

Helpful hint

Tie wraps and tape away from the rear of the connector will allow the wire to be sealed properly.

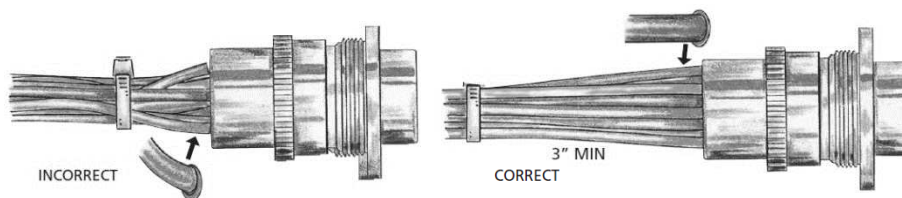

Helpful hint

Harness design should permit filling the connector cavities from the center out in order to provide support for the center of the harness and to allow easier connector assembly.

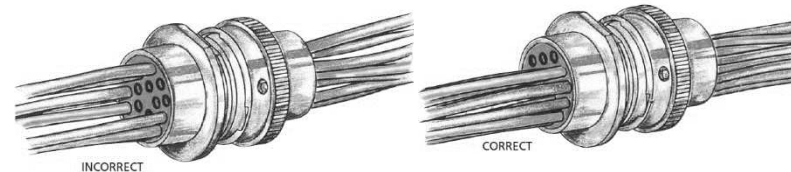

Helpful hint

A contact removal tool taped or tie wrapped to the harness will make it easily available should repairs be needed.

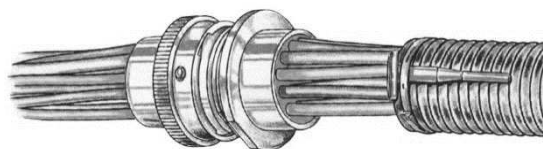

7. VISUAL AID

Below shows a typical application of the HD30 Series Connector. This illustration should be used by production personnel to ensure a correctly applied product. Applications which DO NOT appear correct should be inspected using the information in the proceeding pages of this specification and in the instruction, material shipped with the product or tooling.

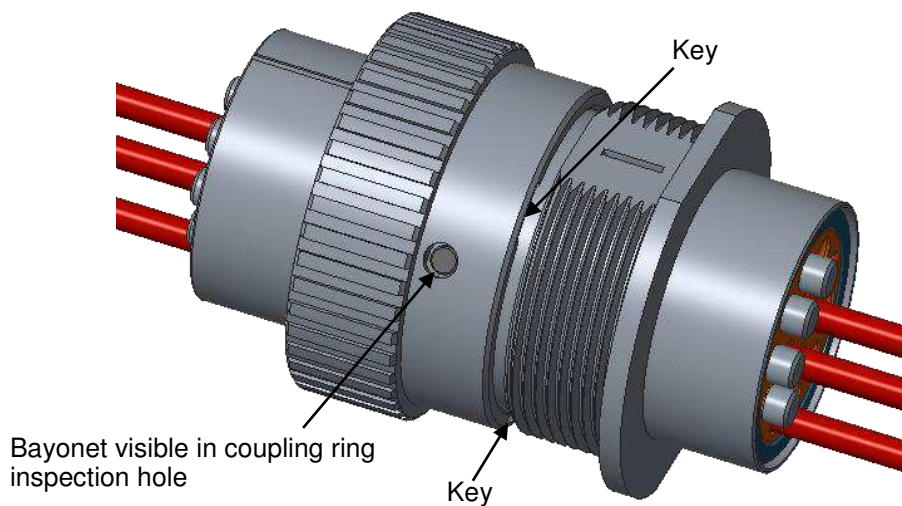
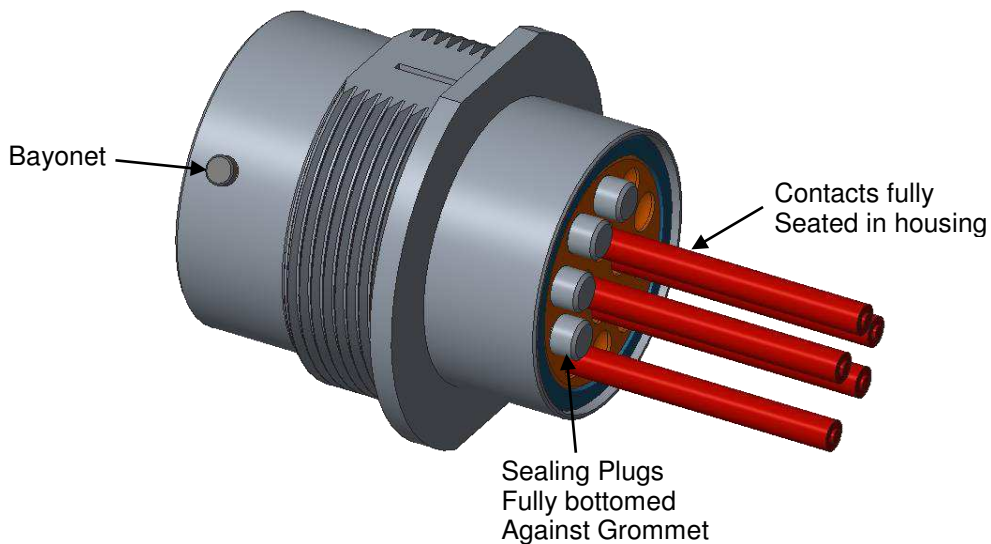

8. REVISION HISTORY

Rev Ltr	Brief Description of Change	Date	Dwn	Apvd
A	Initial Release	06/22/2018	JA	DM
B	Add information in section of Receptacle Mounting, add image in section of panel Installation, and add information of torque for Cable Clamp with Bushing.	11/12/2018	JA	DM
B1	Page 11. Corrected PN error for HDC36-24 and corrected Used On. HDC36 is used on rcpt and HDC34 is used on plug	11/13/2019	DM	DM
C	General formatting and added hyperlinks throughout document Sec 2.4 Added 108-151000, 108-151004, 114-151004, 114-151006 Sec 2.5 Add 408-151066, 408-151078, 408-151083 Page 9 Added Newton to breakaway force Page 13 Added Crimp Sleeve Reducer section Page 13 Added Extended PCN Pin section Sec 3.4 Add 114-151004, 114-151006. Deleted 0425-205-0000 Sec 3.8 (is) 108-151014 (was) 108-108-151015 Sec 4 (is) 108-151014 (was) 108-108-151015 Sec 5 Added 114-151004. Deleted 0425-205-0000	12/16/2019	DM	DM
D	Page 22 Corrected panel nut mounting torque for size 18 & 24. (is) size 18: 260-280 in-lb [29.4-31.6 NM]; size 24 350-375 in-lb [39.5-42.6 NM]	12/26/2019	DM	DM
D1	Page 11 Updated Protective Dust Cap Section Information and Image	06/2/2022	AP	IG
D2	Page 1 Updated tolerance from +/- .005 [+/-0.13] to +/- .025 [+/-0.64]. Updated the images of Pin front from Keyshot renders with material color Black. Page 6 Updated the Grommet material from VMQ (Red-Orange) to VMQ (Burnt Orange) Page 12 Added additional Note for Cable clamp with bushing. Page 21 Protective dust cap Images updated.	18/4/2023	GB	IG