

THIS DRAWING IS UNPUBLISHED. RELEASED FOR PUBLICATION
 © COPYRIGHT - By - ALL RIGHTS RESERVED.

REVISIONS					
P	LTR	DESCRIPTION	DATE	DWN	APVD
	H2	REVISED PER ECR-16-013146	19SEP2016	BW	DC

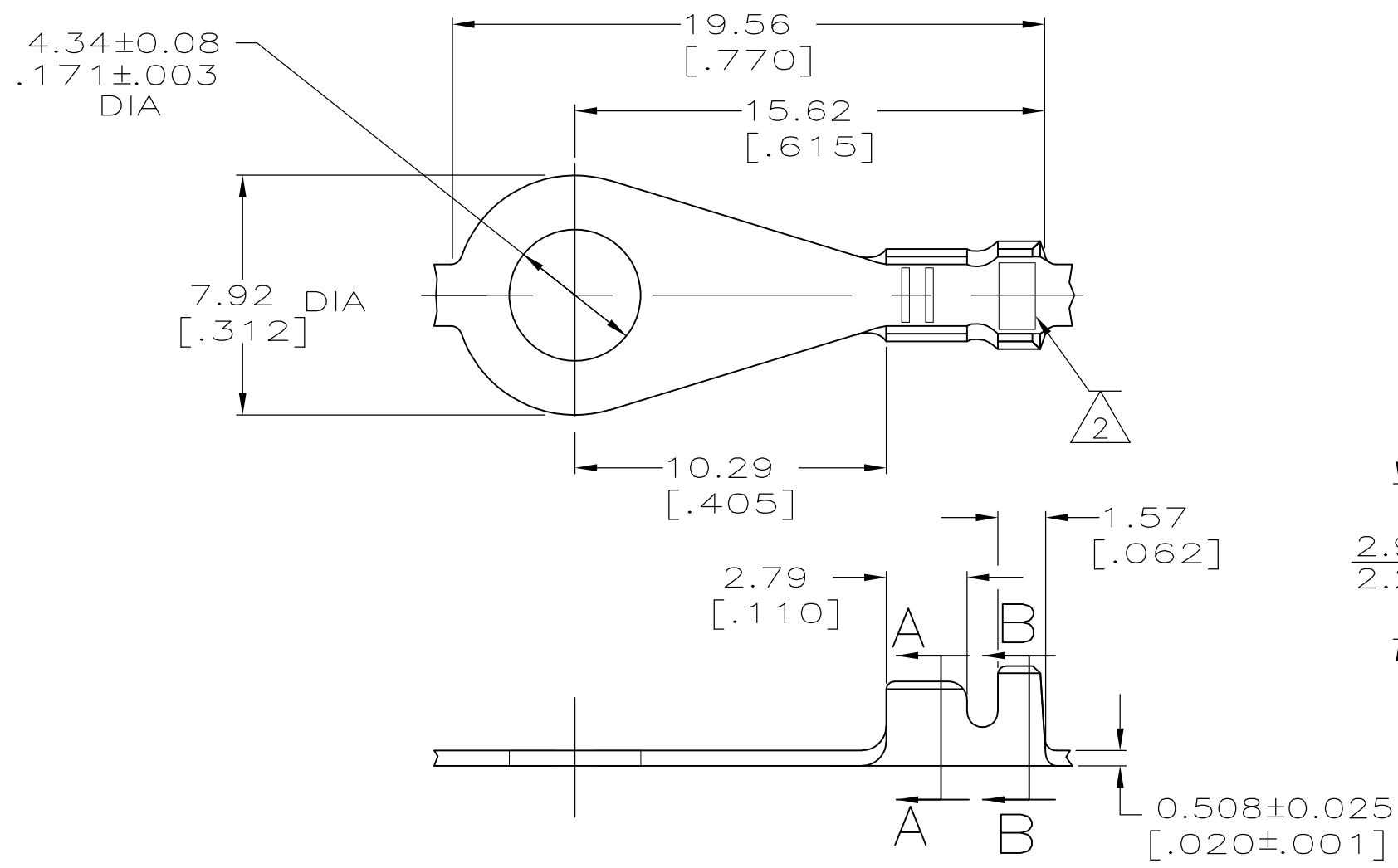

- 1 CONTINUOUS STRIP ON REEL.
- 2 STAMPING: AMP FOR 42508-2
AMP* FOR 42508-3

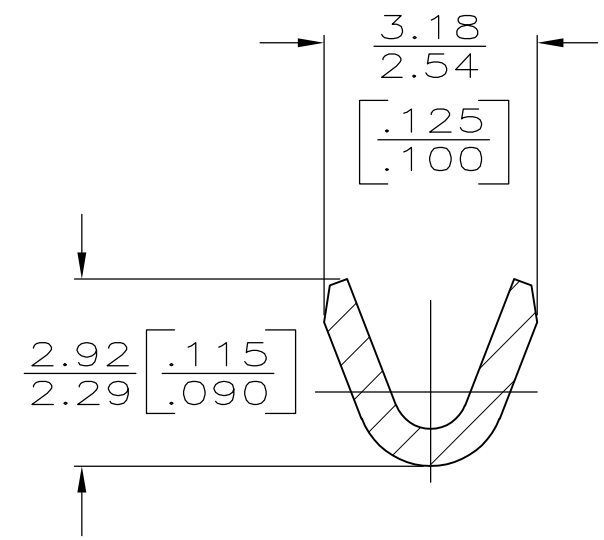

SECTION A-A
SCALE 10:1

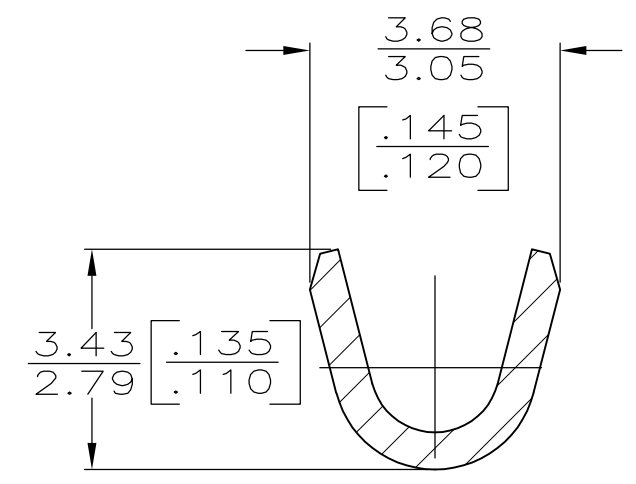

SECTION B-B
SCALE 10:1

H02 PHOS BRZ	1.22-1.98 DIA	0.2 - 0.6mm ²	42508-3
#2 HD BRASS	[.048-.078]	[24-20] AWG	42508-2
MATERIAL	INSULATION RANGE	WIRE RANGE	PART NO

0	.090	2.29	4.32	F	2.03	1.40[.055]	0.6mm ² [20]
F	.100	[.090]	[.170]		[.080]	1.35[.053]	0.3mm ² [22]
						1.27[.050]	0.2mm ² [24]
TYPE	WIDTH	STRIP LENGTH ±0.38 [±.015]	TYPE	WIDTH	±0.051[±.002] HEIGHT	WIRE	
INSUL BARREL CRIMP			WIRE BARREL CRIMP				

THIS DRAWING IS A CONTROLLED DOCUMENT.

DIMENSIONS: mm [INCHES]

TOLERANCES UNLESS OTHERWISE SPECIFIED:

0 PLC	± -
1 PLC	± -
2 PLC	± 0.25 [.010]
3 PLC	± -
4 PLC	± -
ANGLES	± -

MATERIAL: SEE TABLE

FINISH: TIN PLATING

DWN P FORTNEY 5/13/91
 CHK JR RUTH 5/13/91
 APVD G YETTER 5/13/91

STE TE Connectivity

NAME: RING

PRODUCT SPEC: -

APPLICATION SPEC: -

WEIGHT: 0.000000

CUSTOMER DRAWING

SIZE: A3 CAGE CODE: 00779 DRAWING NO: C-42508 RESTRICTED TO: -

SCALE: 5:1 SHEET: 1 OF 1 REV: H2