

Verpackt im Gurt in Anlehnung an DIN IEC 60286-3
 tape on reel packaging according to DIN IEC 60286-3
 Verpackungseinheit: 280 Stück
 packaging unit: 280 pcs

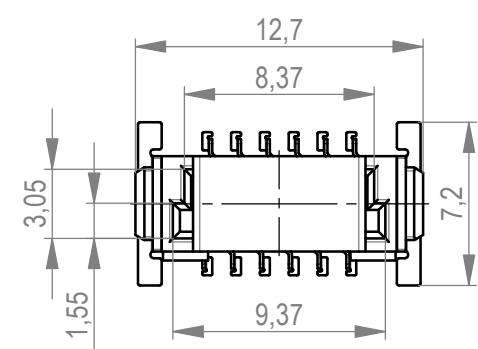

ohne Ansaughaube - without hood

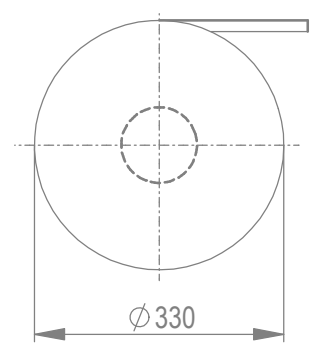
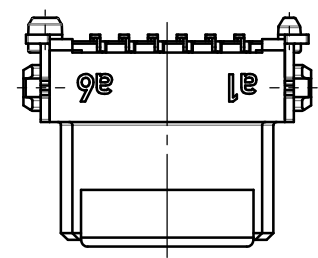
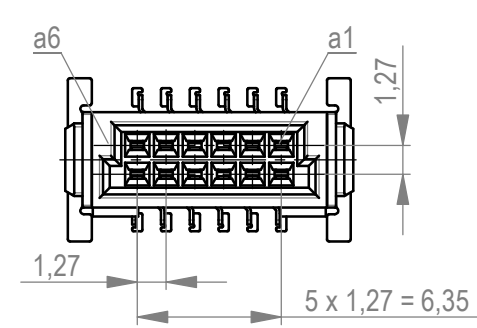

Abspulrichtung - reel off direction

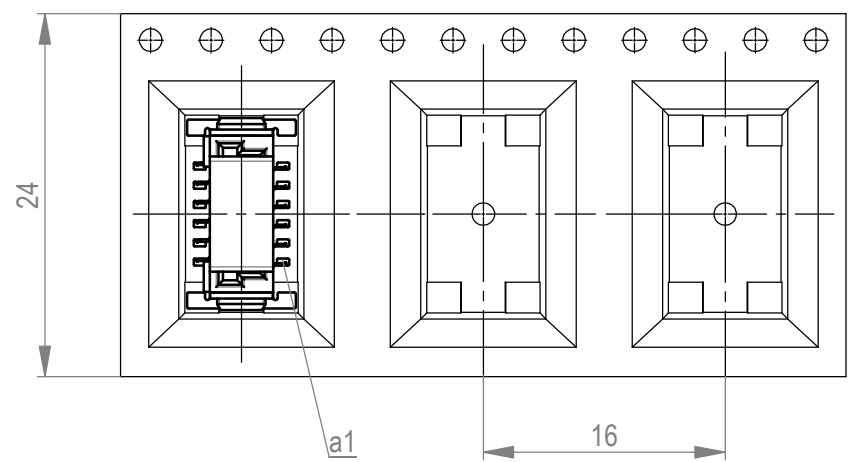

Leiterplatten-Layout Vorschlag für SMT
 PCB-Layout Proposal for SMT

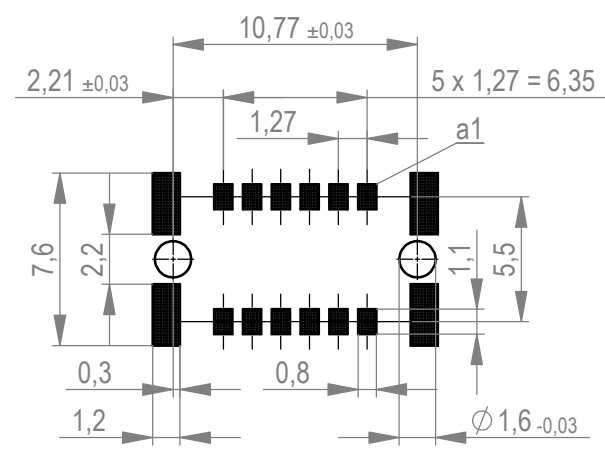

Anforderungsstufe 1
 performance level 1

Kontaktbereich vergoldet
 mating area gold plating

Anschlussbereich verzinkt 4-6 µm
 terminal area 4-6 µm tin plating

Koplanarität der Anschlüsse ≤ 0,1 mm
 coplanarity area of termination ≤ 0,1 mm

BA 7-03 - Standard Bauhöhe
 type 7-03 - standard assembly height

Weitergabe sowie Vervielfältigung dieses Dokuments, Verwertung und Mitteilung seines Inhalts sind verboten, soweit nicht ausdrücklich gestattet. Zuwiderhandlungen verpflichten zu Schadenersatz. Alle Rechte für den Fall der Patent-, Gebrauchsmuster- oder Geschmacksmusterertragung vorbehalten. The reproduction, distribution and utilization of this document as well as the communication of its contents to others without express authorization is prohibited. Offenders will be held liable for the payment of damages. All rights reserved in the event of the grant of a patent, utility model or design.

Die deutsche Version dieser Zeichnung dient nur zur Erleichterung der Handhabung. Bei Abweichungen von dem englischen Original gilt das englische Original. The german version of this drawing has been offered for convenience only and may deviate from the english original. In case of any deviation the English version shall prevail.

Dimension no.	Tolerances	All Dimensions in mm	Scale	5:1
	ISO 8015		Material	
Customer drawing:	Subject to modification without prior notice. Drawing will not be updated.		Federl. SMC-B 12-SMD-BA7-03 Female SMC-B 12-SMD-type7-03 154717	
All rights reserved. Only for Information. To ensure that this is the latest version of this drawing, please contact one of the ERNI companies before using.	ERNI International AG Zürichstrasse 72 8306 Brüttisellen - Zürich Switzerland			
f	30.01.2020		Class	SMCB
Index	Date			I A3