

# XD series

Proportional, industrial hand grip controllers •  
non-contacting Hall effect technology



## DISTINCTIVE FEATURES

- SIL 2 compatible - Redundant Hall sensors
- Resists high axial load (1780 N - 400 lbf)
- Shallow mounting depth of <60 mm (2.36)
- Rated for 10 million lifecycles
- SAE CAN bus J1939-71



## ENVIRONMENTAL SPECIFICATIONS

- Operating Temperature: -40 °C to +85 °C (-40 °F to +185 °F)
- Storage Temperature: -40 °C to +85 °C (-40 °F to +185 °F)
- Above Panel Sealing: Up to IP67 (subject to handle configuration)
- Humidity: IEC 60068-2-38
- Thermal shock: SAE J1455 section 4.1.3.2
- Salt spray: IEC 60068-2-11
- Random vibration: IEC 60068-2-64
- Sinusoidal vibration: IEC 60068-2-6
- EMC Emissions:
  - Radiated Emissions Level: ECE/324/Add.9:2012; CISPR 25:2002
  - Radiated Emissions Level: CISPR 25:2008
- EMC Immunity:
  - ESD: ISC 10605:2008; criteria A
  - Radiated immunity: ISO 11452-2:2004; criteria B
  - Bulk current injection immunity: ISO 11452-4:201; criteria A
  - Pulse 1, Pulse 2a, Pulse 2b, Pulse 3a, Pulse 3b, Pulse 4, Pulse 5a: ISO 7637-2:2011; criteria A



# XD series

Proportional, industrial hand grip controllers • non-contacting Hall effect technology



## ELECTRICAL SPECIFICATIONS

- Technology: Redundant Hall effect sensor
- Supply voltage range: 6 - 35 VDC
- Typical current consumption: 12 V @ 53 mA
- Transient overvoltage max: 40 V
- Reverse polarity Max: -1000 VDC
- Output signal: SAE CANbus J1939-71
- Connections: Deutsch DTM04-6p



## ELECTRICAL CONNECTIONS

- Six position connector: Deutsch DTM04-6P
- Wire: 22 AWG, PTFE insulation with expandable sleeve
- Length: 6:00" +/- 0.5" (bottom of joystick to connector)



## MECHANICAL SPECIFICATIONS

- Operation: Two axis
- Deflection angle:  $\pm 20^\circ$  in X and Y directions
- Operating torque, breakout: .68 Nm \*
- Operating torque, 50% travel: .8 Nm \*
- Operating torque, 100% travel: 1.5 Nm \*
- Maximum axial load: 400 lbf.
- Expected life: 10 million lifecycles (X and Y axis)
- Lever Action (centering): Spring return



## MATERIALS

- Shaft: Stainless steel
- Boot: Silicone
- Handles: Glass filled nylon
- Bezel: Hard black anodized aluminum
- Body: Aluminum
- Cover: Zinc plated steel
- Weight: 800 g

\* Operating force: configuration option "L"



## PANEL CUT-OUT

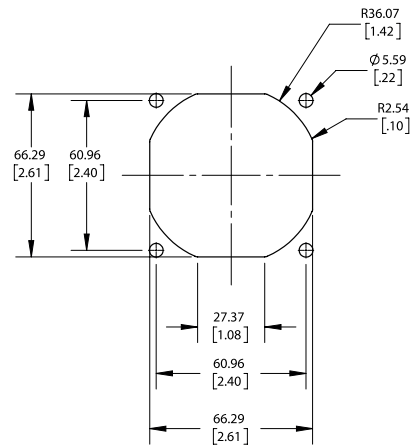

## CAN J1939 INTERFACE SPECIFICATION

The XD Series utilizes redundant Hall effect sensors to measure the primary X and Y axis. The CAN controller support various button configurations as well as proportional thumbwheels and mini-joysticks for additional axis data.

All axis and button data are delivered on a CAN 2.0B compliant physical interface. Two additional signals allow configuration of the controller Source Address. Controller messages are delivered per the SAE J1939-71 message protocol.

### CAN 2.0B INTERFACE PARAMETERS

- Baud rate: 250 Kbps
- Transmission repetition rate: 50 ms to 80 ms \*\*
- BJMI/EJMI interval time: 20 ms
- Terminating resistor: No  
(available by special request to factory)
- Connection to Deutsch DTM04-6P connector:

Pin	Color	Function
1	White	CAN Lo
2	Green	CAN Hi
3	Blue	Source Address SEL 1
4	Orange	Source Address SEL 0
5	Black	Ground
6	Red	6 - 35 VDC

\*\* Transmission repetition rate is dependent upon the faceplate configuration.

Proportional, industrial hand grip controllers •  
non-contacting Hall effect technology



## CAN J1939 INTERFACE SPECIFICATION (CONTINUED)

### CAN MESSAGE PROTOCOL

- Primary Axis and button data on Basic Joystick Message 1 (BJM1):
  - Priority: 3
  - Base PGN: 0xFDD6
  - Source address: 0x10<sup>1</sup>
  - Data field: 8 bytes
- Redundant Axis data on Extended Joystick Message 1 (EJM1):
  - Priority: 3
  - Base PGN: 0xFDD7
  - Source address: 0x10<sup>1</sup>
  - Data field: 8 bytes
- Additional thumbwheels and mini-joysticks data on Extended Joystick Message 2 (EJM2):
  - Priority: 3
  - Base PGN: 0xFDD9
  - Source address: 0x10<sup>1</sup>
  - Data field : 8 bytes

Note 1: Alternate source addresses can be configured by grounding of the blue and/or orange wires.

- Source address= 0x10: ORANGE= floating , BLUE= floating (default)
- Source address= 0x20: ORANGE= floating, BLUE= grounded
- Source address= 0x30: ORANGE= grounded, BLUE= floating
- Source address= 0x40: ORANGE= grounded, BLUE= grounded

### BJM1 DATA FIELD STRUCTURE:

START POSITION (BYTE/BIT)	LENGTH (BITS)	FUNCTION
1/1	2	Primary X-axis neutral position status
1/3	2	Primary X-axis left position status
1/5	2	Primary X-axis right position status
1/7 to 2/8	10	Primary X-axis position data
3/1	2	Primary Y-axis neutral position status
3/3	2	Primary Y-axis down position status
3/5	2	Primary Y-axis up position status
3/7 to 4/8	10	Primary Y-axis position data
6/1	2	Button 4 status
6/3	2	Button 3 status
6/5	2	Button 2 status
6/7	2	Button 1 status
7/1	2	Button 8 status
7/3	2	Button 7 status
7/5	2	Button 6 status
7/7	2	Button 5 status
8/5	2	Button 10 status
8/7	2	Button 9 status

Note: If faceplate configured with n buttons, Trigger and/or paddle would be respectively positioned in Button n+1 and Button n+2.

### EJM1 DATA FIELD STRUCTURE:

START POSITION (BYTE/BIT)	LENGTH (BITS)	FUNCTION
1/1	2	Redundant X-axis neutral position status
1/3	2	Redundant X-axis left position status
1/5	2	Redundant X-axis right position status
1/7 to 2/8	10	Redundant X-axis position data
3/1	2	Redundant Y-axis neutral position status
3/3	2	Redundant Y-axis down position status
3/5	2	Redundant Y-axis up position status
3/7 to 4/8	10	Redundant Y-axis position data

### EJM2 DATA FIELD STRUCTURE:

START POSITION (BYTE/BIT)	LENGTH (BITS)	FUNCTION
1/1	2	A-axis neutral position status
1/3	2	A-axis left position status
1/5	2	A-axis right position status
1/7 to 2/8	10	A-axis position data
3/1	2	B-axis neutral position status
3/3	2	B-axis left position status
3/5	2	B-axis right position status
3/7 to 4/8	10	B-axis position data
5/1	2	C-axis neutral position status
5/3	2	C-axis left position status
5/5	2	C-axis right position status
5/7 to 6/8	10	C-axis position data

# XD series

Proportional, industrial hand grip controllers • non-contacting Hall effect technology



## ELECTRICAL INTERFACE AND CONNECTIONS

### DIMENSIONS

#### Handle Interface

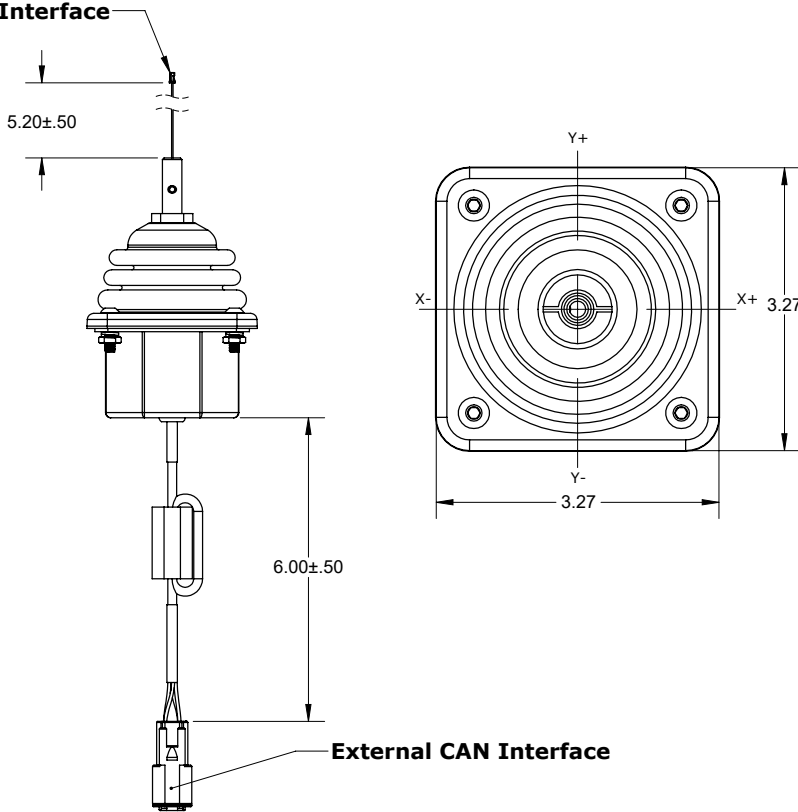

#### External CAN Interface

### HANDLE INTERFACE

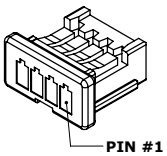

SERIAL LINK MOLEX 5013300400  
CONNECTOR PIN# DESIGNATION

IF UART interface:  
19200 baud, no parity, 8 bit,  
1 stop bit, no hardware flow control

PIN #	FUNCTION
1	Vcc (+5 V)
2	Rx
3	Tx
4	Ground

IF CAN interface:

PIN #	FUNCTION
1	Vcc (+5 V)
2	Rx
3	Tx
4	Ground

### EXTERNAL CAN

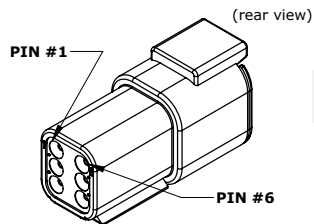

DEUTSCH DTM04-6P  
CONNECTOR PIN# DESIGNATION

PIN #	FUNCTION
1	CAN-LO
2	CAN-HI
3	SEL 1
4	SEL 2
5	Ground
6	Vin

Proportional, industrial hand grip controllers • non-contacting Hall effect technology

## MECHANICAL INTERFACE AND DIMENSIONS

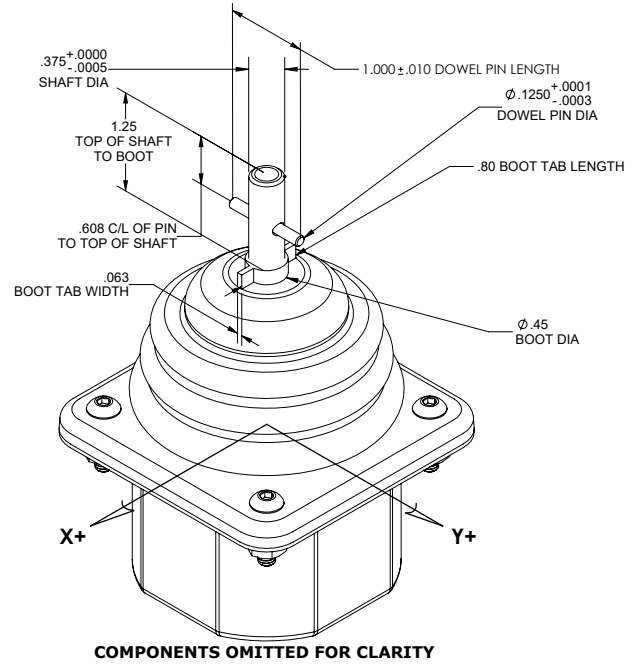
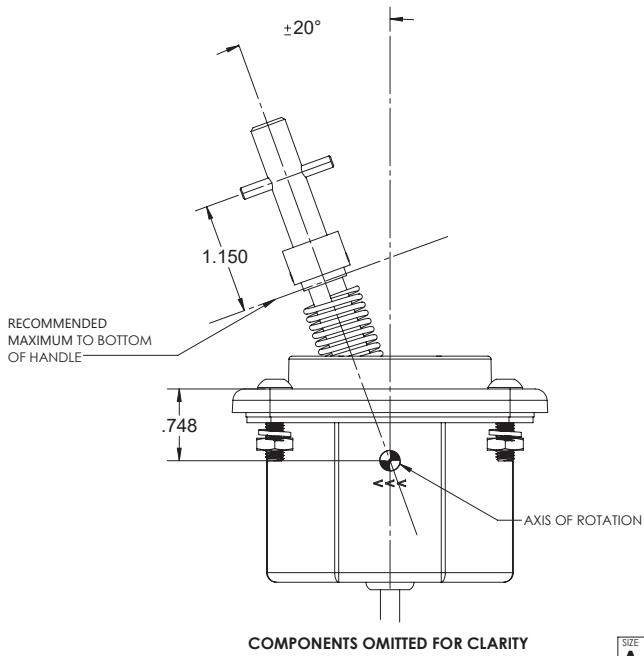

SIZE DWG  
A

# XD series

Proportional, industrial hand grip controllers • non-contacting Hall effect technology

## BUILD YOUR PART NUMBER

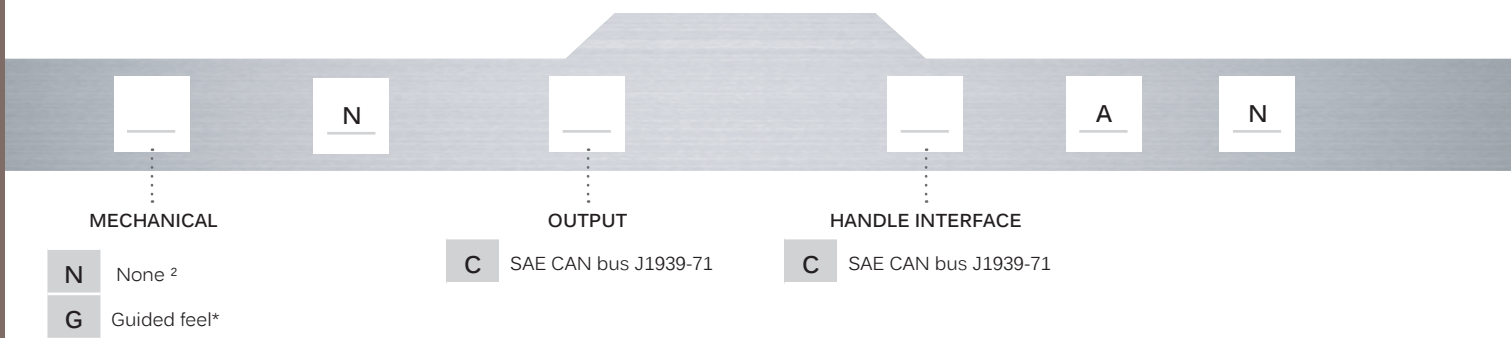
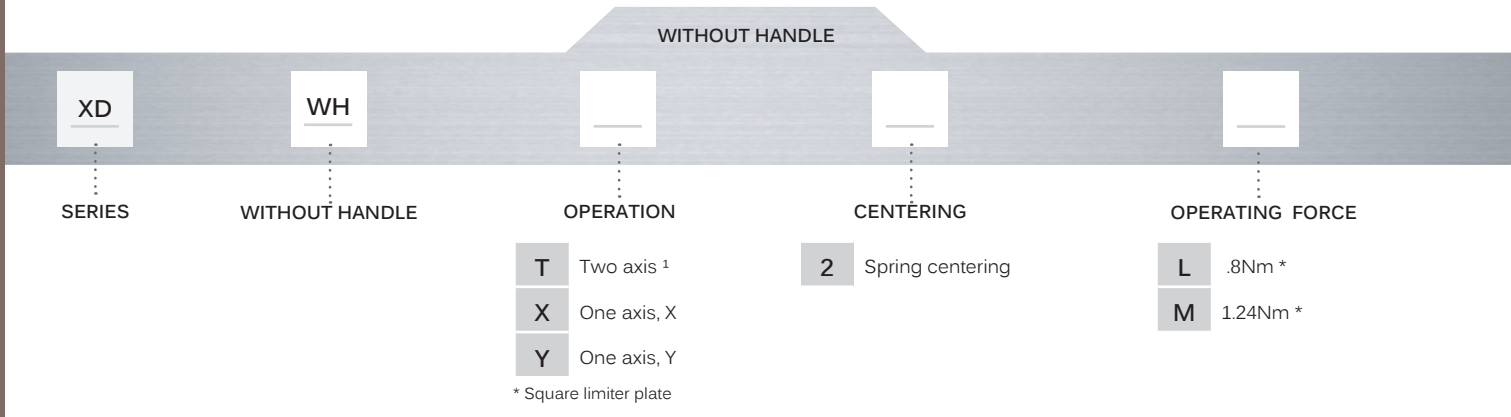

# XD series

Proportional, industrial hand grip controllers • non-contacting Hall effect technology



## BUILD YOUR PART NUMBER

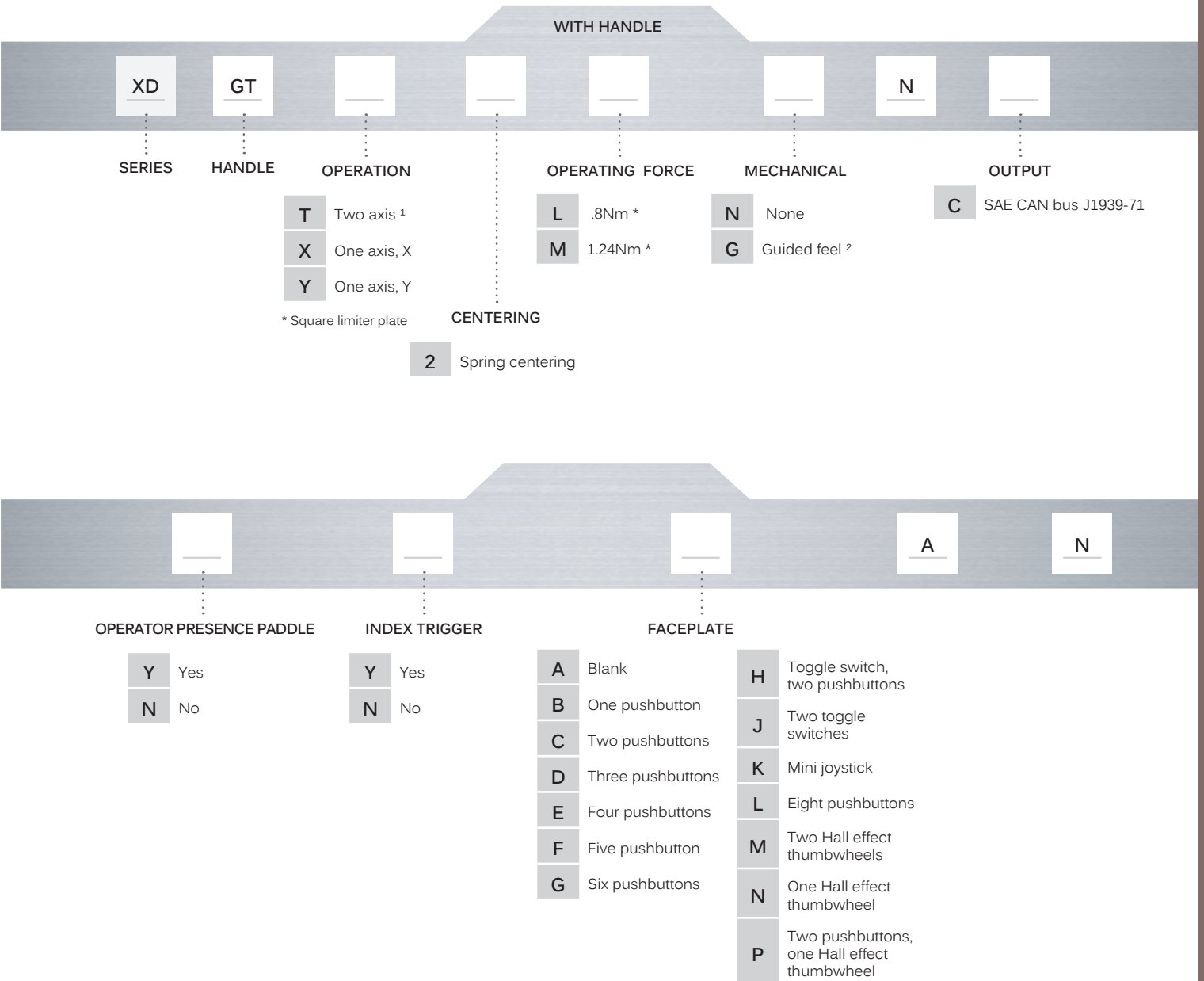

<sup>1</sup> Measured at ±10° (50% travel) from center

<sup>2</sup> The Guided feel option aids the joystick lever into the cardinal direction  
Guided feel option is recommend for "Operating force Option M"  
Operating force measurements for Option M + Guided Feel  
- Breakout force: 1.28 Nm  
- 50% travel: 1.93 Nm  
- 100% travel: 3.21 Nm

# XD series

Proportional, industrial hand grip controllers • non-contacting Hall effect technology

## DIMENSIONS

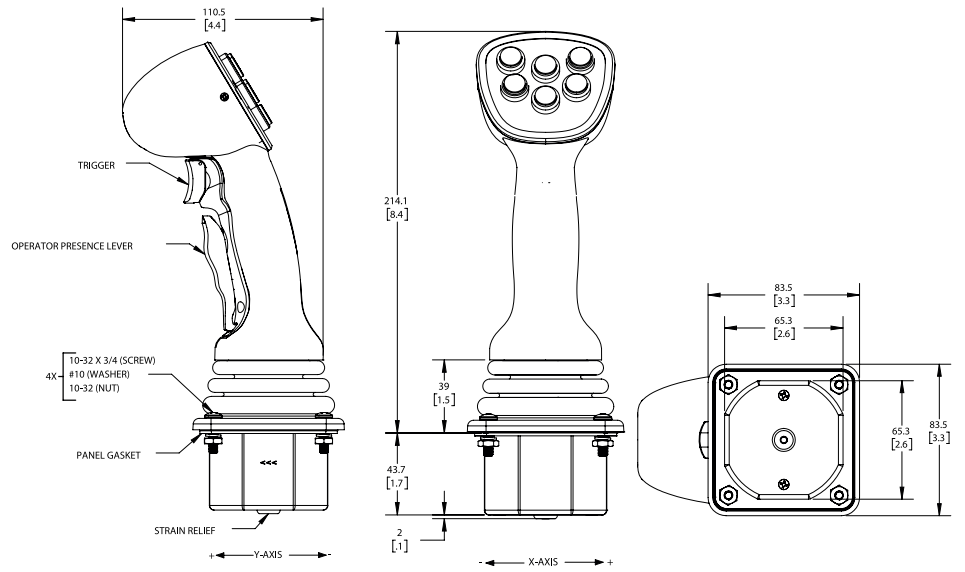

## COMPONENT DESCRIPTIONS



- **MT series:** Sealed toggle switch  
- MOM-OFF-MOM



- **IM series:** Sealed momentary pushbutton  
- Snap action  
- Red



- **TS series :** Miniature Hall effect joystick  
- Two axis, proportional output  
- Castle actuator



- **HR series:** Hall effect thumbwheel  
- One axis, proportional output  
- Black wheel



# XD series

Proportional, industrial hand grip controllers •  
non-contacting Hall effect technology



## FACEPLATE OPTIONS



A



B



C

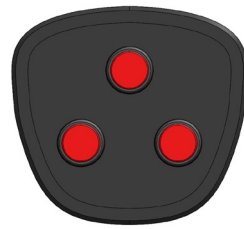

D



E



F



G



H



J



K



L



M



N



P

# XD series

Proportional, industrial hand grip controllers •  
non-contacting Hall effect technology

## BUILD YOUR PART NUMBER

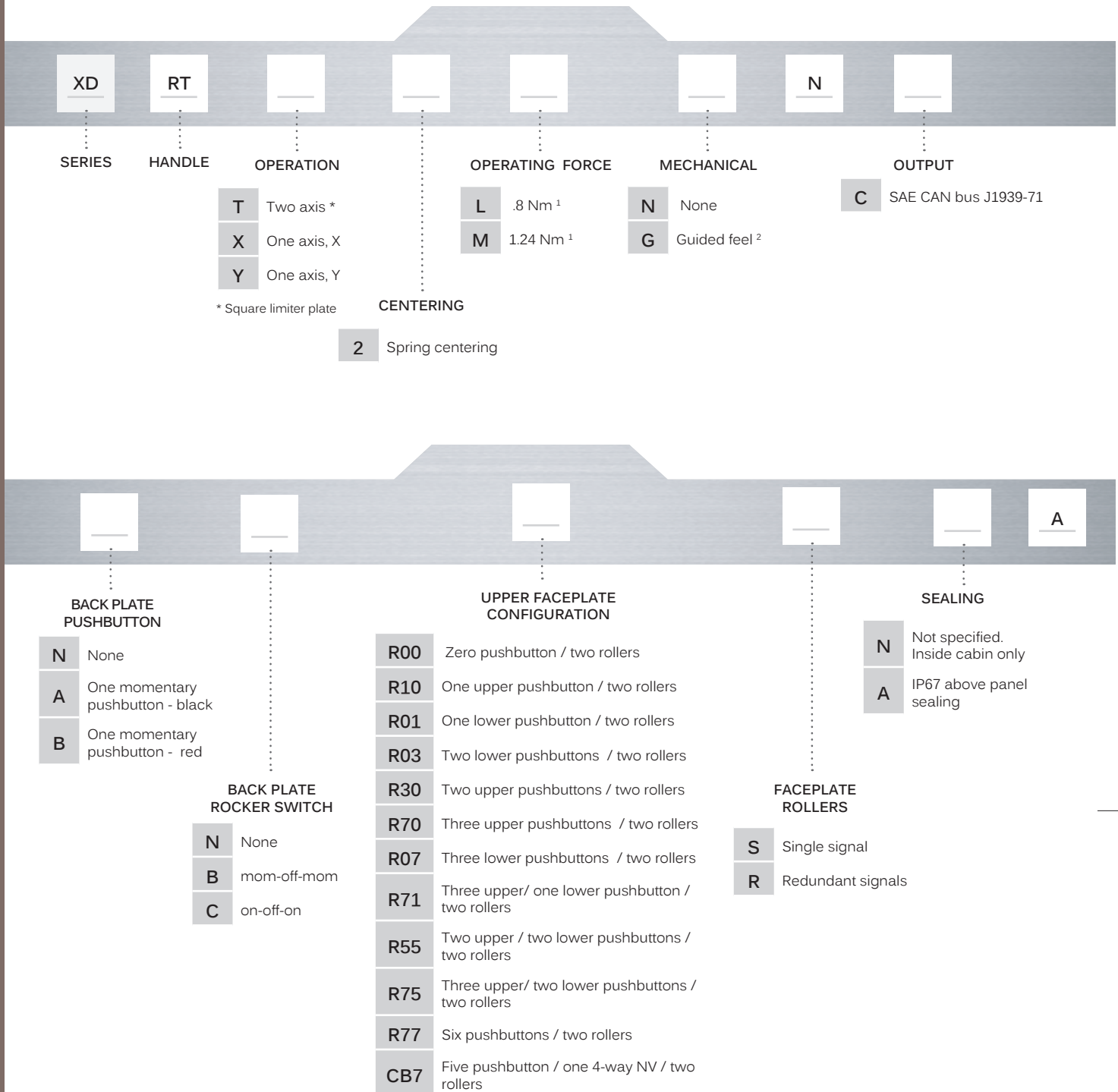

<sup>1</sup> Measured at ±10° (50% travel) from center

<sup>2</sup> The Guided feel option aids the joystick lever into the cardinal direction  
Guided feel option is recommend for "Operating force Option M"  
Operating force measurements for Option M + Guided Feel

- Breakout force: 1.28 Nm
- 50% travel: 1.93 Nm
- 100% travel: 3.21 Nm

Proportional, industrial hand grip controllers • non-contacting Hall effect technology

## CONTOURED FACEPLATE

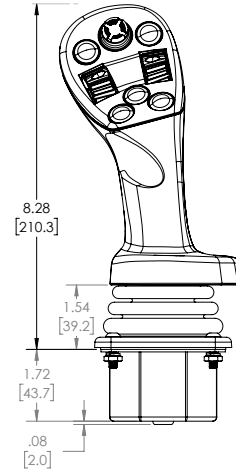
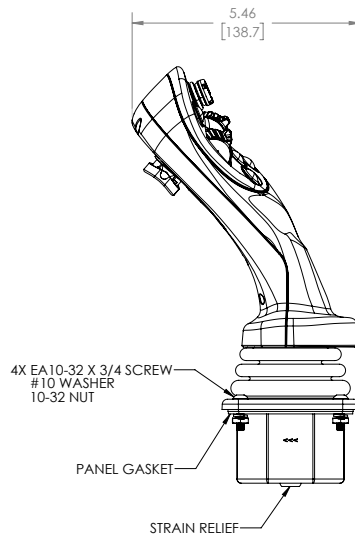

## RAISED FACEPLATE

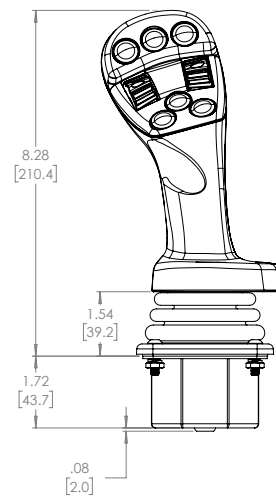
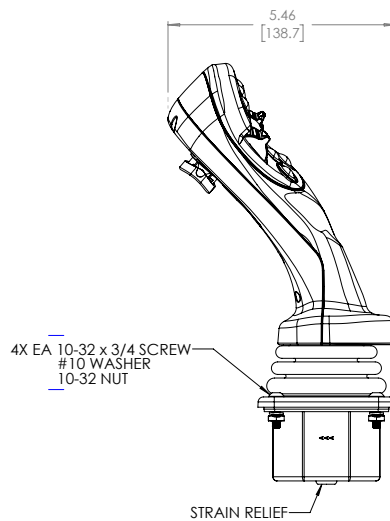

## COMPONENT DESCRIPTIONS



- **IX series:** Sealed momentary pushbutton
  - Protective elastomer boot
  - IP67 panel sealed
  - Black
- **IS series:** Sealed momentary pushbutton
  - Tactile feedback
  - IP67 panel sealed
  - Black
- **FNR series:** Three position rocker switch
  - Mom-off-mom actuation
  - IP69K panel sealed



- **NV series :** 4 way navigation switch
  - Tactical momentary actuation
  - IP67 panel sealed
- **HR series:** Hall effect thumbwheel
  - One axis, proportional control
  - Single or redundant outputs
  - Optional IP67 panel sealing
  - Black

# XD series

Proportional, industrial hand grip controllers • non-contacting Hall effect technology

## BACK PLATE OPTIONS



N no pushbutton  
N no rocker switch



N no pushbutton  
B mom-off-mom rocker switch



A black pushbutton  
N no rocker switch

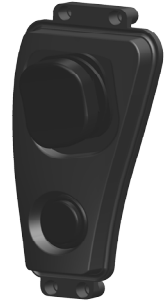

A black pushbutton  
B mom-off-mom rocker switch

## RAISED FACEPLATE OPTIONS



R00



R10



R01



R03



R30



R70



R07



R71



R55



R75



R77

# XD series

Proportional, industrial hand grip controllers •  
non-contacting Hall effect technology



## CONTOURED FACEPLATE OPTION



CB7