

# SLQ-QT105 Datasheet

## High Purity Milliliter Flow Meter for Hydrocarbons

- Sensitive to low flow rates
- Straight flow channel
- Maximum flows up to 2 ml/s
- Fast measurement response for dosing monitoring
- Super-fast sampling speed



### 1 Product Summary

The SLQ-QT105 Flow Meter offers an exceptional liquid flow sensing performance based on a thermal microsensor technology. It is made for use with hydrocarbon based liquids. The fluidic part of the device is based on just a straight flow path and no moving parts. Due to the short response time the SLQ-QT105 allows to monitor highly dynamic processes such as fast dosing operations. In many applications this allows to increase process reliability and reduce consumption of precious media.

### 2 Sensing Performance with Reference Medium Isopropyl Alcohol

In Table 1 the flow meter's performance for use with Isopropyl Alcohol (IPA) is given. For other hydrocarbons the values will be different as the performance depends on the used medium. The repeatability depends on the averaging time of the signal. Longer averaging time leads to better repeatability of the flow measurement (see table 1).

Table 1: Model specific performance of SLQ-QT105 for IPA (all data at 23°C, 1 bar<sub>abs</sub> unless otherwise noted)

Parameter	Condition	SLQ-QT105	Units
Maximum Flow Rate <sup>a</sup>		2000	µl/s
Repeatability (1σ) (whichever is greater)	0.2 sec averaging time	2	% m.v.
		0.3	% F.S.
Flow Detection Response Time		< 50	ms
Accuracy <sup>b</sup>		10	% m.v.
Response Time On Power-Up		< 120	ms
Optimal Heat Up Time	for constant flow measurement	500 – 1500	ms
Mounting Orientation Sensitivity <sup>c</sup>	for IPA; 23°C	< 5	µl/s
Operating Temperature		+20 ... +25	°C
Operating Pressure		12	bar
Proof Pressure		32	bar
Ambient Storage Temperature	(empty flow channel)	-10... +60	°C

<sup>a</sup> Medium IPA

<sup>b</sup> With IPA, 50 - 2000 µl/s

<sup>c</sup> Normal position: horizontal flow channel, connector horizontally.

### 3 Sensing Performance with Other Media but Isopropyl Alcohol

The flow meter's measurement performance for media other than Isopropyl Alcohol (IPA) depends strongly on the properties of the liquid. The performance for most hydrocarbon based liquids, i.e. solvents and solvent based photoresists, is similar to the performance with IPA, with the exception of the absolute accuracy. The flow meter's calibration is only valid for IPA. For other liquids the repeatability of the measurement is still excellent. It is the user's responsibility to test the flow meter with all liquids that are to be used with the flow meter.

Special care has to be taken with media that contain water. The flow meters maximum flow rate for measuring pure water is 15 ml/min. For liquids with water content the maximum flow rate will be between 15 ml/min and 120 ml/min, depending on the mixture composition.

Table 2: Examples for common media

Medium	Maximum Flow Rate	Units
IPA	2000	μl/s
Ethanol, Methanol, Gasoline	~830	
Acetone	~670	
Diesel, Petroleum, Veg. Oils	1300 (1600)	
Silicon Oil, Ether	< 1600	
Water	250	

#### 3.1 Exchangeability

Every SLQ-QT105 is calibrated for IPA. This makes the flow meters also exchangeable for use with other media, meaning that once the flow meters are characterized for a particular medium the same values can be used for further flow meters. Depending on the media, variations between flow meters of 6– 20% are typical.

### 4 Liquid Temperature Management

Due to the used microsensors technology, the amount of thermal energy introduced into the liquid is very small. It is generally recommended to avoid heat-up of the liquid in the thermal flow meter however, by turning off the micro heater when the liquid is not flowing. For instruction on how to control the sensor's micro heater and on the low power mode refer to separate documentation.

When measuring according to the instruction for dosing measurements, the heat up behavior of the liquid is given in table 3.

Table 3: Heat-up behavior (for IPA)

Heater Setting	Flow Situation	Examined Waiting Time	Heat up of liquid
Heater off & analog cell off	flow / no flow	unlimited	< 0.3 °C
Heater off & analog cell on	flow / no flow	unlimited	< 1 °C
Heater on	no flow	1 second after heater turned on	< 0.075 °C
Heater on	no flow	2 seconds after heater turned on	< 0.15 °C
Heater on	no flow	> 2 seconds after heater turned on	< additional 0.1°C / second, maximal 4°C
Heater on	constant flow X ml/min		≈ 0.03 °C / X
Heater in low power mode <sup>a</sup>	no flow	unlimited	< 1°C

<sup>a</sup> Low power mode is only available when Sensor is operated with the RS485 Sensor Cable

## 5 On-Site Flow Path Cleaning

The most important rules in handling the sensor are:

- avoid letting fluid dry in the flow meter that could leave deposits
- *never* attempt to mechanically clean the sensors inner flow channel.

Since the sensor relies on a thermal measurement through the quartz glass wall of the inner flow channel, one must take precautions to avoid any build-up or deposits that could alter the thermal properties of the capillary and thus influence the measurement precision. Also when changing from one liquid to another, sufficient cleaning procedures have to be performed to avoid non-soluble depositions on the flow channels wall.

Before storing the sensor, always drain the fluid, flush with cleaning agent, and allow to air dry. In most cases flushing with acetone and finally IPA will suffice. The cleaning agent (detergent, solvent, etc) should be chosen for its effectiveness in removing the liquid media and compatibility with wetted materials.

Flow meters do not need periodic cleaning unless the medium has a tendency to leave deposits, or flow meters have been disconnected from the fluidic path and not properly flushed. The residue left by the drying fluids can alter sensor performance or even plug the capillary. You may try cleaning it by flushing with acetone and IPA.

## 6 RS485 Interface Specifications

The SLQ-QT105 flow sensor offers a RS485 digital interface using Sensirion's RS485 Sensor Cable. With this, power supply and safe operation of multiple devices via one single RS485 bus is possible. A special feature of this RS485 unit is an internal ring buffer allowing to independently record flow rate data for a certain period of time.

Separate documentation is available on request for

- Sensirion RS845 Sensor Cable
- Communication Protocol according to RS485 Sensirion HDLC Standard
- Communication via Sensirion Driver DLL for Windows
- Support Documents for Dosing Monitoring

Table 4: Specifications of digital interface

Parameter	SLQ-QT105 operated with the RS485 Sensor Cable	Units
Digital Interface	RS485	
Power Supply DC, VDD	4.5 – 5.5	V
Operating Current (typical)	20	mA
Operating Current (max., during communication)	100	mA

Ground of power supply and ground of the communication system have to be connected.

### 6.1 Overvoltage Protection, EMI

#### 6.1.1 PELV Device

The SLQ-QT105 flow meter is classified as a PELV (Protected extra-low voltage) system according to IEC 61140. PELV system are defined as an: "electrical system in which the voltage cannot exceed ELV (extra-low voltage, an ELV circuit is defined as one in which the electrical potential of any conductor against earth (ground) is not more than 120 volts for direct current) under normal conditions, and under single-fault conditions, except earth faults in other circuits".

### 6.1.2 EMI

The flow meter complies with EN55011-1. This does only concern the flow meters body and not the cable. It is the task of the user to confirm that the electromagnetic radiation of the cable and communication setup satisfies his demands.

## 6.2 Mechanical Specifications

Table 5: Mechanical specifications

Parameter	SLQ-QT105
Fluid Connector Standard (Fittings)	Super 300 Type Pillar Fitting 4x3mm
Pressure Drop at 120 ml/min IPA, 25°C,	< 10 mbar
Flow Channel, Inner Diameter	1.95 mm
Protection Class	IP32
Total Mass	~ 45 g

## 6.3 Wetted Parts

Table 6: Wetted Materials

Part	Material
Ports	PCTFE
Sealing Part	PFA
Capillary	Quartz

## 7 Physical Dimensions

Dimensions in mm:

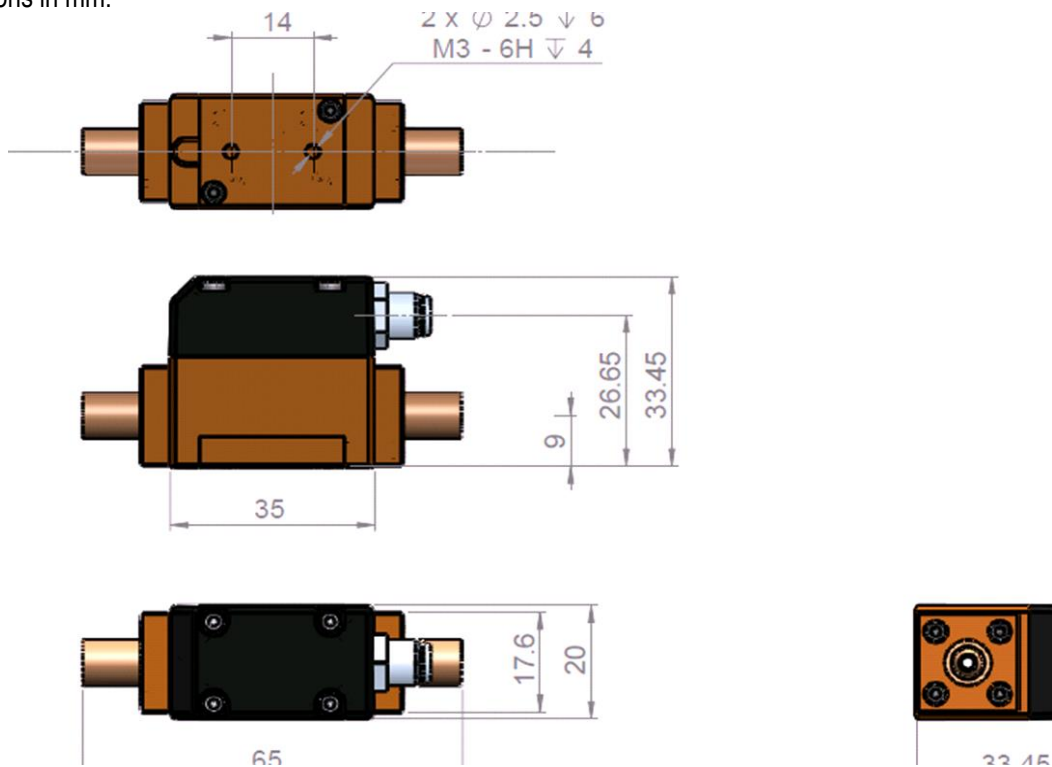

## 8 Flow Meter Lifetime

The expected lifetime of the flow meter is 3 years of constant operation, under the condition that the sensor is used

- with non-depositing and non-abrasive liquids
- in a clean and dry environment free of aggressive vapours
- in an environment with constant temperature within the range specified in chapter 2.
- in compliance with all other handling instructions.

The expected lifetime is defined as the mean time between failures.

Failures are defined as:

- reduction of sensing repeatability below the specified limits.
- electrical failure as: digital communication impossible or not complying with the expected behaviour.

## 9 Limitation of Particle Contamination

The flow path of each SLQ-QT105 flow meter is flushed with ultra-pure water as a final production step before packaging. The flow meter is then sealed in PE foil under ISO 5 clean room conditions. The particle count limit for the flushing process is <1 detected particle per 1 ml of water, and the detection limit for particles is 100 nm diameter.

## 10 Ordering Information

For OEM applications, the flow meter can be purchased in larger quantities without any additional parts. For optimum performance, Sensirion recommends using the SLQ-QT105 flow meter in combination with the SCC1 interface cables.

For laboratory use and technology evaluation, the flow meter can be purchased in smaller quantities without any additional parts. For optimum performance, Sensirion recommends using the SLQ-QT105 flow meter in combination with the SCC1 interface cables.

Table 7: Ordering Information

Product	Article Number
Liquid Flow Meter SLQ-QT105	1-100808-01

Interface Cables:

SCC1-RS485 2m Sensor Cable Pigtail	1-100804-01
SCC1-RS485 5m Sensor Cable Pigtail	1-101122-01
SCC1-ANALOG 2m Sensor Cable Pigtail	1-101072-01
SCC1-ANALOG 10m Sensor Cable Pigtail	1-101219-01
SCC1-CURRENT 5m Sensor Cable Pigtail	1-101667-01
SCC1-USB Sensor Cable 2m	1-101007-01

# Important Notices

## Warning, personal injury

**Do not use this product as safety or emergency stop devices or in any other application where failure of the product could result in personal injury. Do not use this product for applications other than its intended and authorized use. Before installing, handling, using or servicing this product, please consult the data sheet and application notes. Failure to comply with these instructions could result in death or serious injury.**

If the Buyer shall purchase or use SENSIRION products for any unintended or unauthorized application, Buyer shall defend, indemnify and hold harmless SENSIRION and its officers, employees, subsidiaries, affiliates and distributors against all claims, costs, damages and expenses, and reasonable attorney fees arising out of, directly or indirectly, any claim of personal injury or death associated with such unintended or unauthorized use, even if SENSIRION shall be allegedly negligent with respect to the design or the manufacture of the product.

## ESD Precautions

The inherent design of this component causes it to be sensitive to electrostatic discharge (ESD). To prevent ESD-induced damage and/or degradation, take customary and statutory ESD precautions when handling this product.

## Warranty

SENSIRION warrants solely to the original purchaser of this product for a period of 12 months (one year) from the date of delivery that this product shall be of the quality, material and workmanship defined in SENSIRION's published specifications of the product. Within such period, if proven to be defective, SENSIRION shall repair and/or replace this product, in SENSIRION's discretion, free of charge to the Buyer, provided that:

- notice in writing describing the defects shall be given to SENSIRION within fourteen (14) days after their appearance;
- such defects shall be found, to SENSIRION's reasonable satisfaction, to have arisen from SENSIRION's faulty design, material, or workmanship;
- the defective product shall be returned to SENSIRION's factory at the Buyer's expense; and
- the warranty period for any repaired or replaced product shall be limited to the unexpired portion of the original period.

This warranty does not apply to any equipment which has not been installed and used within the specifications recommended by SENSIRION for the intended and proper use of the equipment. EXCEPT FOR THE WARRANTIES EXPRESSLY SET FORTH HEREIN, SENSIRION MAKES NO WARRANTIES, EITHER EXPRESS OR IMPLIED, WITH RESPECT TO THE PRODUCT. ANY AND ALL WARRANTIES, INCLUDING WITHOUT LIMITATION, WARRANTIES OF MERCHANTABILITY OR FITNESS FOR A PARTICULAR PURPOSE, ARE EXPRESSLY EXCLUDED AND DECLINED.

SENSIRION is only liable for defects of this product arising under the conditions of operation provided for in the data sheet and proper use of the goods. SENSIRION explicitly disclaims all warranties, express or implied, for any period during which the goods are operated or stored not in accordance with the technical specifications.

SENSIRION does not assume any liability arising out of any application or use of any product or circuit and specifically disclaims any and all liability, including without limitation consequential or incidental damages. All operating parameters, including without limitation recommended parameters, must be validated for each customer's applications by customer's technical experts. Recommended parameters can and do vary in different applications.

SENSIRION reserves the right, without further notice, (i) to change the product specifications and/or the information in this document and (ii) to improve reliability, functions and design of this product.

Copyright© 2001-20011, SENSIRION.  
CMOSens® is a trademark of Sensirion  
All rights reserved.

## RoHS and WEEE Statement

The SLQ product family complies with requirements of the following directives:

- EU Directive 2002/96/EC on waste electrical and electronic equipment (**WEEE**), OJ13.02.2003; esp. its Article 6 (1) with Annex II.
- EU Directive 2002/95/EC on the restriction of the use of certain hazardous substances in electrical and electronic equipment (**RoHS**), OJ 13.02.2003; esp. its Article 4.

# Headquarter and Subsidiaries

## Sensirion AG (Headquarters)

Laubisruetistr. 50  
CH-8712 Staefa ZH  
Switzerland  
Phone: +41 44 306 40 00  
Email: [info@sensirion.com](mailto:info@sensirion.com)  
[www.sensirion.com](http://www.sensirion.com)

## Sensirion Inc., USA

Phone: +1 312 690 5858  
Email: [info-us@sensirion.com](mailto:info-us@sensirion.com)  
[www.sensirion.com](http://www.sensirion.com)

## Sensirion Korea Co. Ltd.

Phone: +82 31 337 7700~3  
Email: [info-kr@sensirion.com](mailto:info-kr@sensirion.com)

## Sensirion Japan Co. Ltd.

Phone: +81 3 3444 4940  
Email: [info-jp@sensirion.com](mailto:info-jp@sensirion.com)  
[www.sensirion.com/jp](http://www.sensirion.com/jp)

**Sensirion China Co. Ltd.**

Phone: +86 755 8252 1501

Email: [info-cn@sensirion.com](mailto:info-cn@sensirion.com)

[www.sensirion.com/cn](http://www.sensirion.com/cn)

**Sensirion Taiwan Co. Ltd**

Phone: +886 3 5506701

Email: [info-tw@sensirion.com](mailto:info-tw@sensirion.com)

To find your local distributor, please visit [www.sensirion.com/distributors](http://www.sensirion.com/distributors).

## Revision History of the SLQ-QT105 Datasheet – for INTERNAL USE only

Revision	Date	Changes		Author
		Chapter	Description	
0.7	10.11.10	all	Complete Re-Work	UKA
0.8	16.11.10	2	Operating Humidity added in Table 1	JHO
		3	Chapter 3.1 & 3.2 inserted (Maximum Flow Rate Depending on...)	JHO
		5	Section "Shock and Vibration" inserted	UKA
		10.3	Chapter 10.3 inserted (Fixed Flow Unit Scale Factor)	UKA
		10	Warning "Attention Electromagnetic Disturbances" extended by CE certification statement ( <b>fast transient noise</b> )	UKA
		10	Added word "protocol" in first paragraph	UKA
		5	Section "Shock and Vibration" 6 inserted	UKA
		2, 3, 3.1	Flow rate changed from ml/min to µl/s	SBR
0.10	7.12.10	All	Converted to F Version.	JHO
0.11	20.12.2010	Title	New Name SLQ-QT105	JHO
		2	Rel Humidity Deleted	
		2	Repeatability of 2 sec averaging deleted and for 0.2 sec increased 2/0.3	
		8.1	The repeatabilities given are the 3σ interval assuming a Gaussian distribution of the measured values (integrals of each dosing volume). <b>deleted</b>	
		Clean Package	Deleted	
1.0	19.01.2011	Title	New Picture	
		Important Notes	Quality Symbols gelöscht	
2	28.02.2011	Front page	New Real Picture of Sensor	JHO
		8.1	Repeatability corrected 1.75% to 2.00%	
3	04.07.2011	Table 5	Fluid Connectors changed to Pillar	JHO
		Chapter 6	Fluid Connectors changed to Pillar	
		Title	Preliminary removed	
4		Appendix	RS485 Communication moved and rewritten to chapter	JHO
			Electrical and Interface Specifications completely changed to reflect RS485	
		Appendix 9	New: ... measurement the waiting time <b>must</b> not vary from ... Changed: "Do the measurement in the continuous measurement mode of the RS485 Sensor Cable and allow no "holes" in the stream by retrieving measurement data before buffer is full"	
		Chapter 7	Picture Physical Dimensions corrected	
5		Chapter 4	Text changed; max temperature at no flow but heater on deleted from Table	JHO
		Chapter 9.1	The term priming was renamed to initialization because priming has a different meaning in the industry and is often misunderstood. The text was slightly altered.	
		Chapter 9.2	The term priming was renamed to initialization because priming has a different meaning in the industry and is often misunderstood.	
6		Table 1 and 5	Proof and Operating pressure added	JHO
7		6.4	deleted	SDE
		All	re-work	SDE



		3	Water mx. flow rate increased to 15 ml/min	SDE
		9	deleted	SDE
		6.2	ID changed to 1.95mm	SDE
		9	Ordering information added	SDE
8	April 2013	New 9	Limitation of Particle Contamination added	SDE
9	February 2022	New 10	Order Information	LTS