

REVISIONS					
P	LTR	DESCRIPTION	DATE	DWN	APVD
A2		REV PER ECO-20-007878	05JUN2020	SJ	JH
A3		Updated drawing	10JUN2020	SJ	JH
A4		ADD NEWLY PARTS	13AUG2020	SJ	JH
B		REVISED PER ECO-20-015489	04NOV2020	SJ	JH

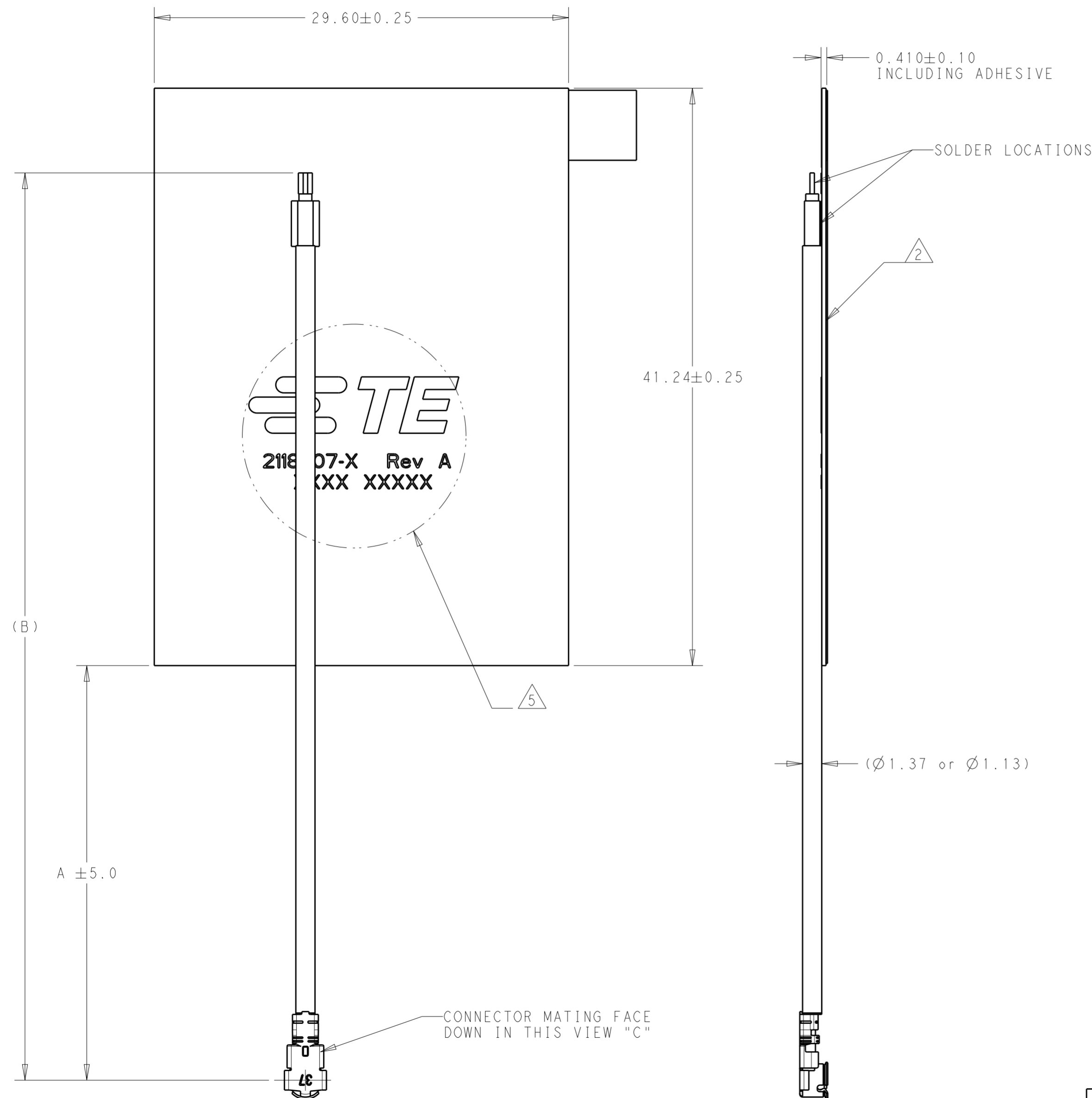

NOTES: UNLESS OTHERWISE SPECIFIED.

- FABRICATE TO MEET IPC - 6012, CLASS 2. INSPECT TO MEET IPC - A - 600, CLASS 2.
- MATERIAL :
 - A. FR-4 PCB + DOUBLE SIDED ADHESIVE 0.41 THK.
 - B. ADHESIVE WITH LINER ON THE BACK SIDE. REMOVE LINER TO APPLY
- PACKAGING: SINGULATED PARTS TO BE SECURELY BAG WRAPPED, BAGGED OR VACUUM PACKED IN BULK.
- CONSULT TE CONNECTIVITY DATA SHEET DS2118907.
- SILKSCREEN; WHITE EPOXY INK
 - A. TE LOGO, TE P/N
 - B. WORD REV., FOLLOWED BY THE LATEST REVISION LETTER, AS SHOWN.
 - C. 4 DIGIT DATE CODE : FIRST 2 DIGITS FOR THE WEEK CODE AND THE 2ND TWO DIGITS FOR THE YEAR CODE.
 - OTHERS : SPECIFIC TE SOURCE CODE NUMBER DIGITS AS REQUIRED.

MHF4L (OD:1.13)	(235.2)	200.0	2118907-9
	(185.2)	150.0	2118907-8
	(135.2)	100.0	2118907-7
	(85.2)	50.0	2118907-6
MHF (OD:1.37)	(235.2)	200.0	2118907-5
	(185.2)	150.0	2118907-4
	(135.2)	100.0	2118907-3
	(85.2)	50.0	2118907-2
	(150.0)	114.8	2118907-1
"C" CONNECTOR TYPE	"(B)"	"A"	PART NUMBER

THIS DRAWING IS A CONTROLLED DOCUMENT.		DWN S.J. NOH 29APR2020																
DIMENSIONS: mm		CHK H. SHIN 29APR2020																
TOLERANCES UNLESS OTHERWISE SPECIFIED:		APVD JH. KIM 29APR2020	NAME PCB Ant, MHF/MHF4L, Wi-Fi 6E Triple															
<table border="1"> <tr><td>0 PLC</td><td>±</td></tr> <tr><td>1 PLC</td><td>±</td></tr> <tr><td>2 PLC</td><td>±</td></tr> <tr><td>3 PLC</td><td>±</td></tr> <tr><td>4 PLC</td><td>±</td></tr> <tr><td>ANGLES</td><td>±</td></tr> <tr><td>FINISH</td><td>-</td></tr> </table>		0 PLC	±	1 PLC	±	2 PLC	±	3 PLC	±	4 PLC	±	ANGLES	±	FINISH	-	PRODUCT SPEC -	RESTRICTED TO	
0 PLC	±																	
1 PLC	±																	
2 PLC	±																	
3 PLC	±																	
4 PLC	±																	
ANGLES	±																	
FINISH	-																	
MATERIAL -		APPLICATION SPEC -	SIZE A2	CAGE CODE C-2118907														
-		WEIGHT -	SCALE 4:1 SHEET 1 OF 1 REV B															
CUSTOMER DRAWING																		