

PART NUMBER	DIM "A"	NOTE
211888-0001	Ø 8.8	FOR 6 AWG CABLE
211888-0002	Ø 12.5	FOR 2 AWG CABLE
211888-0003	Ø 5.6	FOR 10 AWG CABLE
211888-0004	Ø 10.6	FOR 4 AWG CABLE
211888-0005	Ø 7.6	FOR 8 AWG CABLE

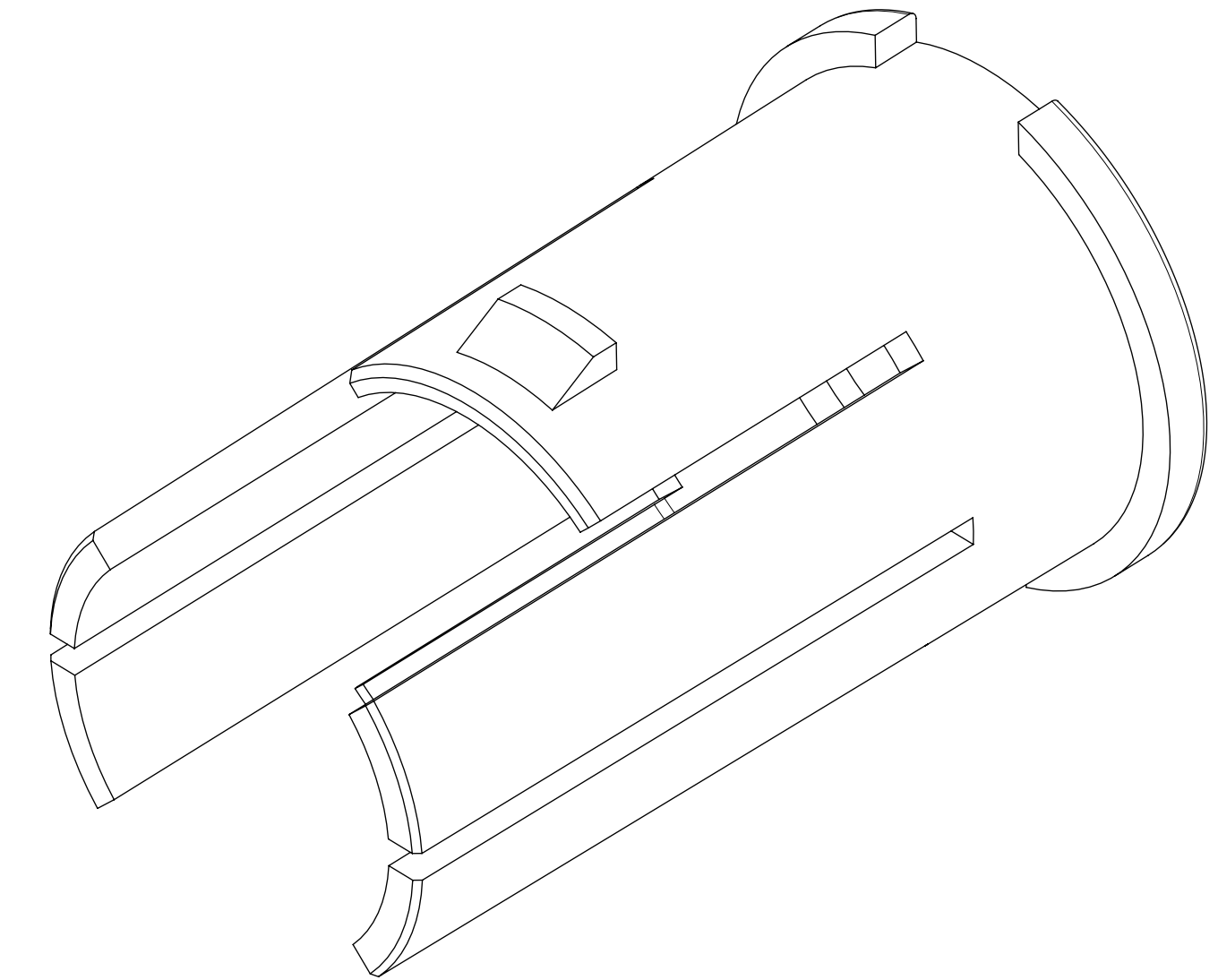
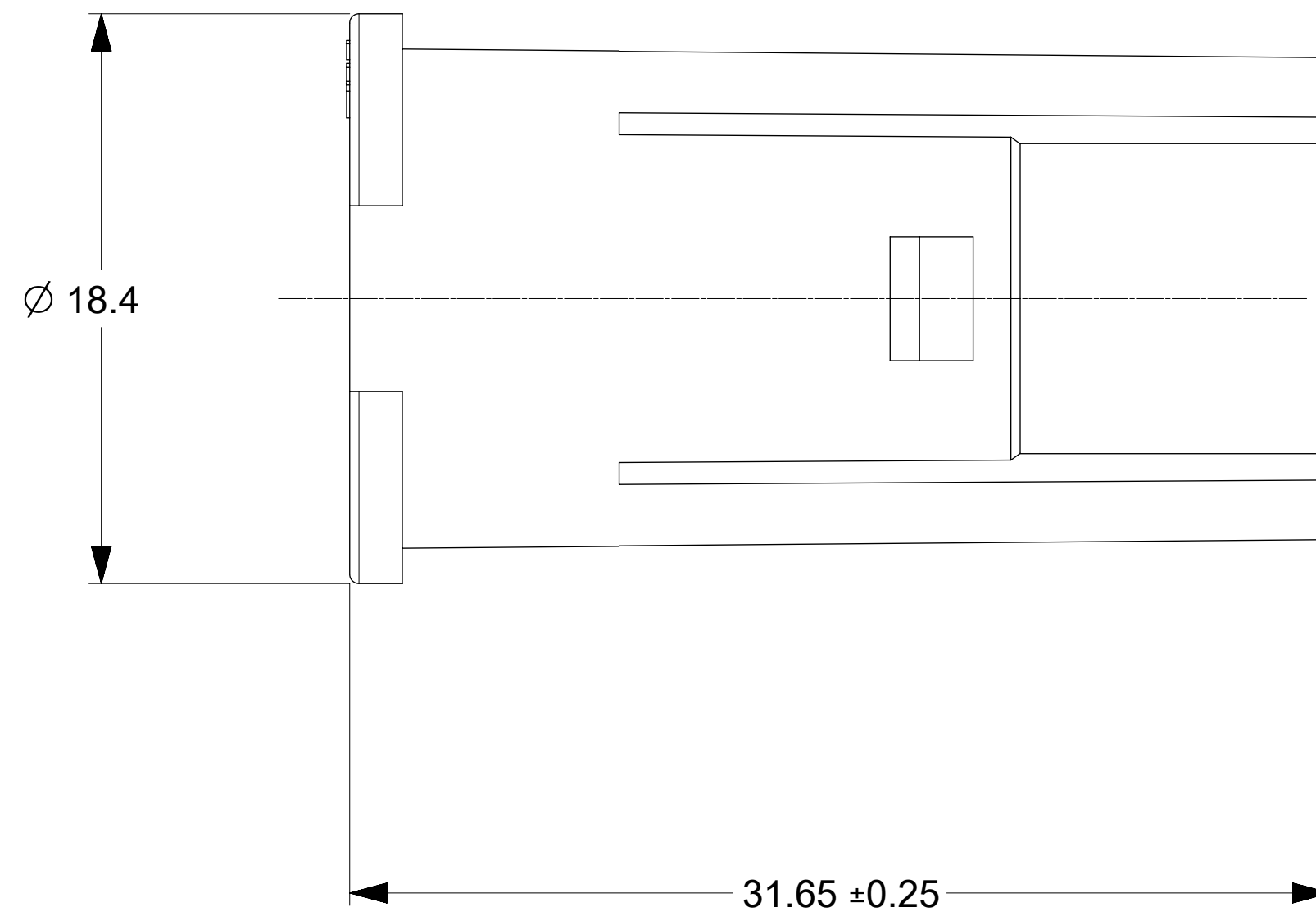
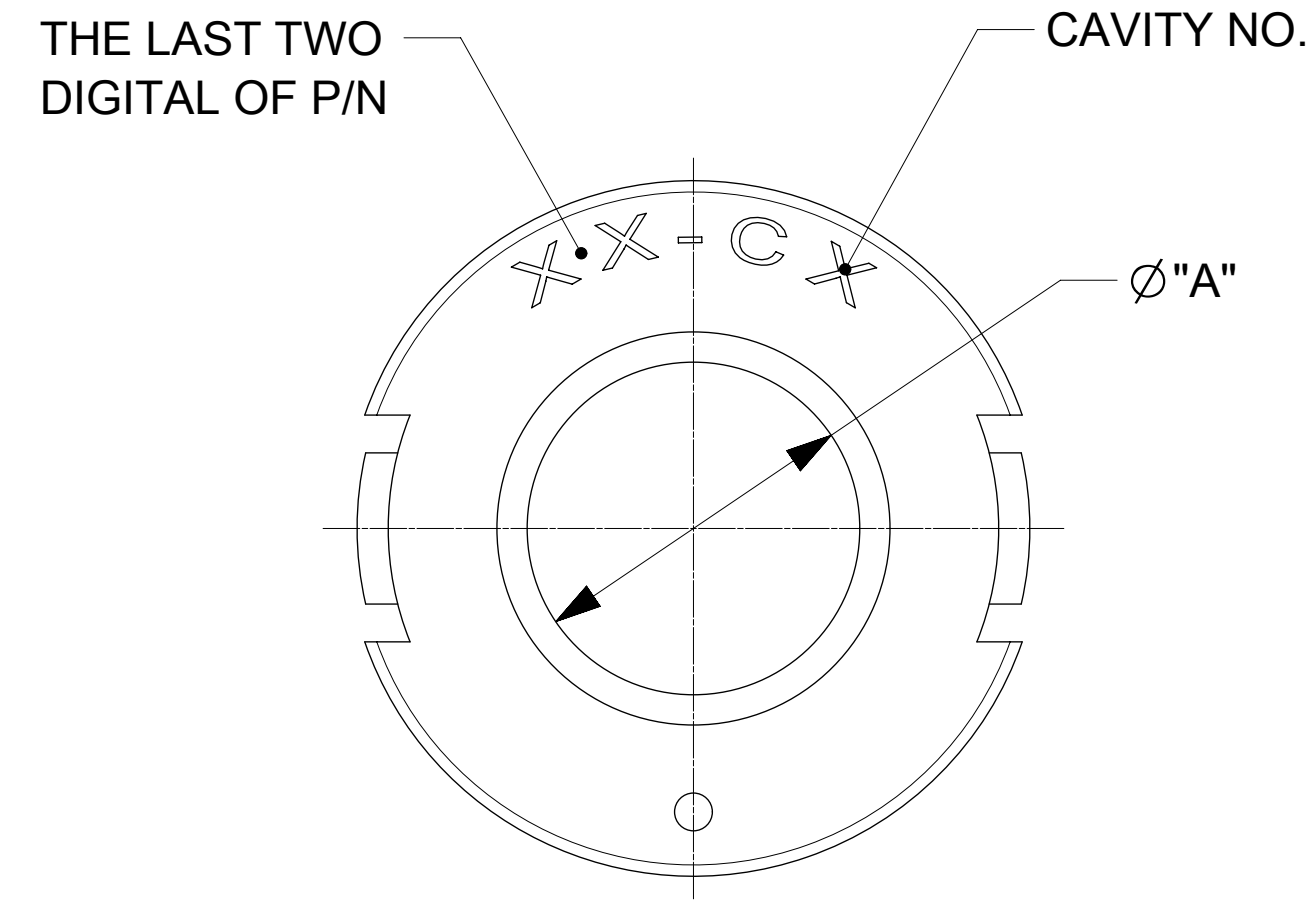

- NOTES:
1. MATERIAL: POLYESTER. COLOR: BLACK; UL94-V0
 2. PACKAGE SPECIFICATION: 2118880000-PK
 3. PRODUCT SPECIFICATION: 2119410000-PS
 4. APPLICATION SPECIFICATION: 2119410000-AS
 5. FOR 6MM CST HARNESS ASSEMBLY, SERIES 211941, 211945, 211948, 211952 ETC.
 6. RoHS COMPLIANT.

THIS DRAWING CONTAINS INFORMATION THAT IS PROPRIETARY TO MOLEX ELECTRONIC TECHNOLOGIES, LLC AND SHOULD NOT BE USED WITHOUT WRITTEN PERMISSION																	
DIMENSION UNITS	SCALE	CURRENT REV DESC:															
mm	2:1	<p>molex</p> <p>RETAINER FOR 6MM CST HARNESS ASSEMBLY</p> <p>PRODUCT CUSTOMER DRAWING</p> <table border="1"> <tr> <td>DOCUMENT NUMBER</td> <td>DOC TYPE</td> <td>DOC PART</td> <td>REVISION</td> </tr> <tr> <td>2118880000-SD</td> <td>PSD</td> <td>000</td> <td>A2</td> </tr> </table>								DOCUMENT NUMBER	DOC TYPE	DOC PART	REVISION	2118880000-SD	PSD	000	A2
DOCUMENT NUMBER	DOC TYPE									DOC PART	REVISION						
2118880000-SD	PSD									000	A2						
GENERAL TOLERANCES (UNLESS SPECIFIED)																	
ANGULAR TOL	± °																
4 PLACES	±																
3 PLACES	±																
2 PLACES	± 0.15																
1 PLACE	± 0.25																
0 PLACES	±																
DRAFT WHERE APPLICABLE MUST REMAIN WITHIN DIMENSIONS		THIRD ANGLE PROJECTION	DRAWING	SERIES	MATERIAL NUMBER	CUSTOMER	SHEET NUMBER										
			D-SIZE	211888	SEE CHART		1 OF 1										
		EC NO: 654348		2021/01/14													
		DRWN: TOMLU		2021/02/02													
		CHK'D: BPISZCZOR		2021/02/02													
		APPR: BPISZCZOR		2021/02/02													
		INITIAL REVISION:		2019/02/20													
		DRWN: TOMLU		2019/08/02													
		APPR: BPISZCZOR		2019/08/02													