

THIS DOCUMENT IS THE PROPERTY OF KEYSTONE ELECTRONICS CORP. AND SHALL NOT BE REPRODUCED, DISTRIBUTED OR USED AS A BASIS FOR MANUFACTURE WITHOUT PRIOR WRITTEN PERMISSION FROM KEYSTONE ELECTRONICS CORP.

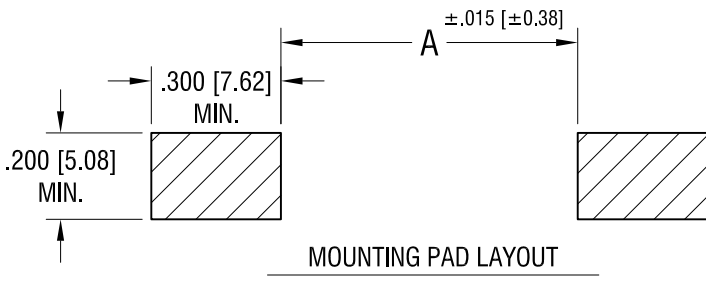

FOR BATTERY SIZE:	'A' DIM.
AAA	1.959 [49.76]
AAAA	1.864 [47.35]

ACTUAL SIZE

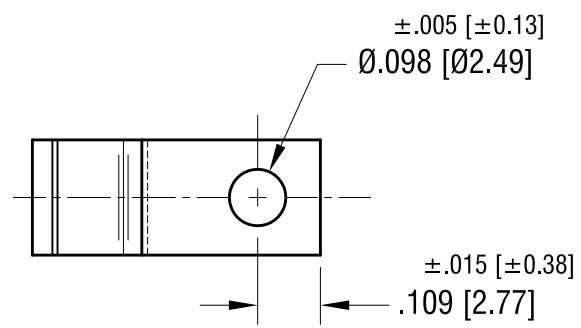
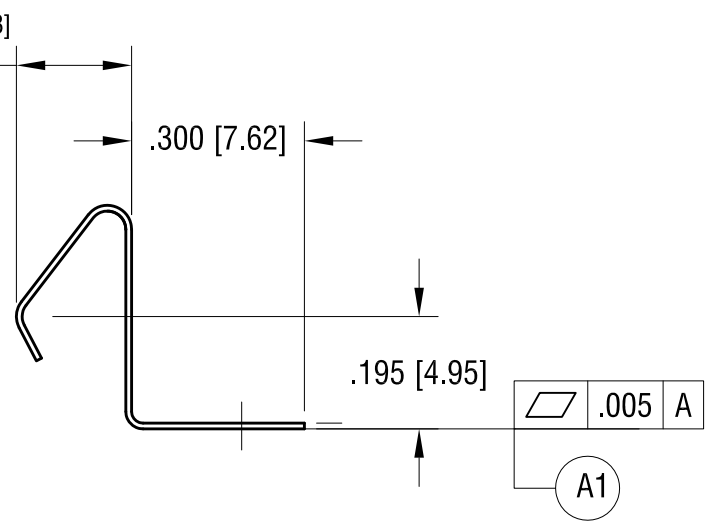
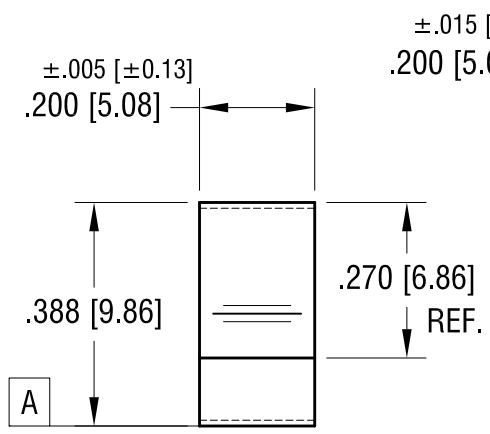
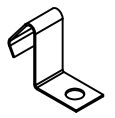

NOTE:
1. HEAT TREAT TO SPRING TEMPER.

ADD FLATNESS (A1)

7.06.20	CHANGE AS PER ECN 20-063	A
DATE	DESCRIPTION	REV.

KEYSTONE ELECTRONICS CORP.		
www.keyelco.com • NEW HYDE PARK, NY 11040 • Tel (516) 328-7500		
PART NAME BATTERY CONTACT, SURFACE MOUNT		
MATERIAL .010 [0.25] TH'K ANNEALED SPRING STEEL		
FINISH MATTE TIN PLATE	DRN BY NT	DATE 7.28.09
	APP'D RH	SCALE 3X
TOLERANCES INCH [MM] DECIMAL ± .010 [±0.25] ANGULAR ± 1° UNLESS OTHERWISE SPECIFIED	CODE C	DWG NO. 5330