

0.445 [11.30]  
+0.004 -0.000  
[+0.100-0.00]

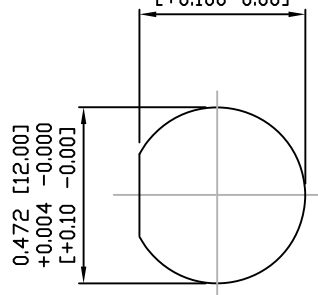

PANEL CUTOUT

PANEL THICKNESS = 0.085" MAX

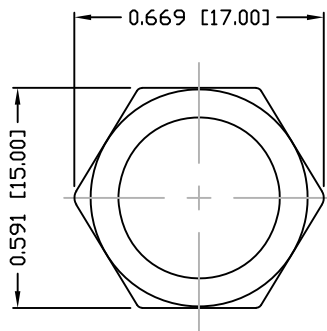

NUT

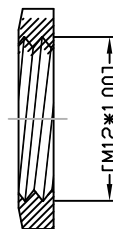

NOTE:

MATERIAL

HOUSING:	PBT UL94V-0, BLACK
CONTACT:	BRASS
SHELL:	BRASS
NUT:	BRASS
O-RING:	EPDM, BLACK
O-RING (INTERNAL):	SILICONE, GREEN
FINISH	
CONTACT:	GOLD PLATED OVER 50u" NICKEL
SHELL:	NICKEL PLATED OVER ALL
NUT:	NICKEL PLATED OVER ALL
ELECTRICAL:	
RATED CURRENT:	5A
RATED VOLTAGE:	125V
INSULATION RESISTANCE:	100 MOhms MIN.
CONTACT RESISTANCE:	10 mOhms MAX.
WATER PROOF:	IP67
ENVIRONMENT:	
OPERATION TEMPERATURE:	-40°C TO +85°C
WIRE GAUGE:	24-28 AWG

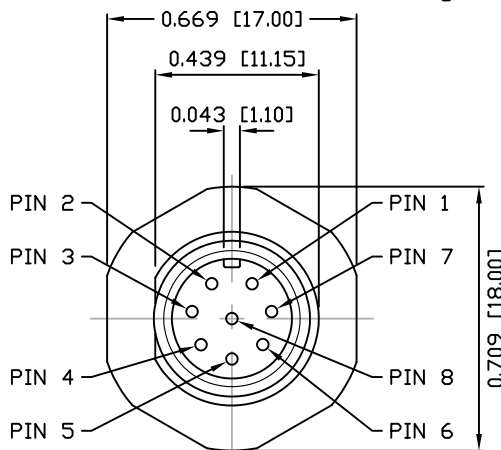
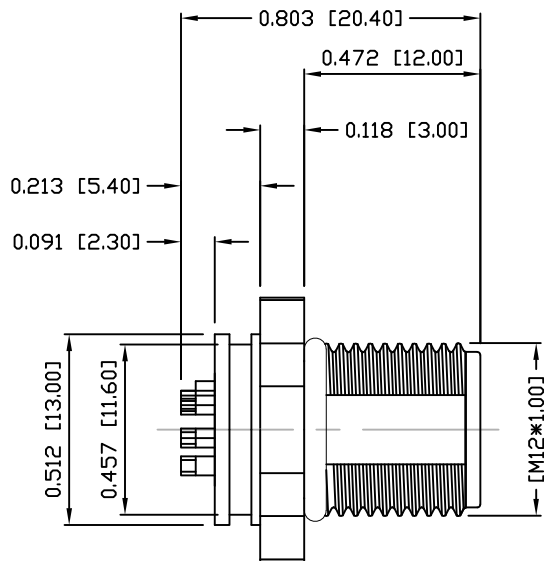

859-008-103R00Y

3 = BRASS/NICKEL SHELL & NUT  
S = STAINLESS STEEL SHELL & NUT

1 = GOLD FLASH  
4 = 10u" GOLD

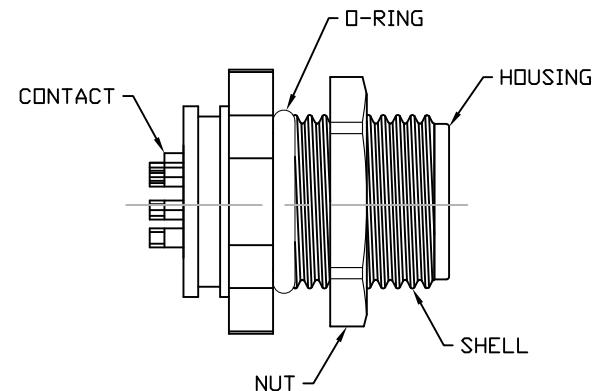

RoHS COMPLIANT

DO NOT SCALE FROM DRAWING



THESE DRAWINGS AND SPECIFICATIONS ARE THE PROPERTY OF NorComp AND SHALL NOT BE REPRODUCED, COPIED OR USED AS THE BASIS FOR THE MANUFACTURE OR SALE OF APPARATUS WITHOUT WRITTEN PERMISSION.

DRAWN:

M. SIGMON

DATE:

03-07-16

NorComp

SCALE:  
NTS

SHEET 1 OF 1

REV 4

DWG NO.

859-008-103R00Y