Ultra-Low Power Stereo CODEC with Audio Enhancement DSP, 2W Stereo Class D Speaker Drivers and Ground Referenced Headphone Drivers

DESCRIPTION

The WM8962B is a low power, high performance stereo CODEC designed for portable digital audio applications.

An integrated charge pump provides a ground referenced output which removes the need for DC-blocking capacitors on the headphone outputs, and uses the Wolfson 'Class-W' amplifier techniques - incorporating an innovative dual-mode charge pump architecture - to optimise efficiency and power consumption during playback. A DC Servo is used to reduce DC ground offsets. This improves power consumption and minimises pops and clicks.

Stereo class D speaker drivers provide 2W per channel into 4Ω BTL loads, with a 5V supply. Low leakage, excellent PSRR and pop/click suppression mechanisms also allow direct battery connection to the speaker supply. Flexible speaker boost settings allow speaker output power to be maximised while minimising other analogue supply currents.

Control sequences for audio path setup can be pre-loaded and executed by an integrated sequencer to reduce software driver development and eliminate pops and clicks via Wolfson's SilentSwitch™ technology.

Flexible input configuration: four stereo inputs or eight mono inputs on Left or Right ADC, with a complete analogue (four single-ended stereo inputs) and digital microphone interface. External component requirements are drastically reduced as no separate microphone, speaker or headphone amplifiers are required. Advanced on-chip digital signal processing performs automatic level control for the microphone or line input.

Stereo 24-bit sigma-delta ADCs and DACs are used with low power over-sampling digital interpolation and decimation filters and a flexible digital audio interface.

A programmable audio enhancement DSP is included with multiple preset algorithms. Virtual Surround Sound widens the stereo speaker audio image, HD Bass enhances low frequencies, and ReTune™ flattens the frequency response of the speaker or microphone path. A configurable DSP includes additional functions such as 3D widening for recording, a 5-band parametric EQ and Dynamic Range Controller.

Two high performance PLLs and one Frequency Locked Loop (FLL) are integrated to enable the user to clock a full audio system.

The WM8962B operates at analogue supply voltages down to 1.7V, although the digital supplies can operate at voltages down to 1.62V to save power. The speaker supply can operate at up to 5.5V. Unused functions can be disabled using software control to save power.

The WM8962B is supplied in a very small W-CSP package, ideal for use in hand-held and portable systems.

FEATURES

- DAC SNR 98dB ('A' weighted), THD -84dB at 48kHz, 1.8V
- ADC SNR 94dB ('A' weighted), THD -85dB at 48kHz, 1.8V
- Stereo Class D Speaker Driver
 - 2W per channel into 4Ω BTL speakers
 - 2W mono (for improved THD)
 - Flexible internal switching clock
- Wolfson 'Class-W' ultra-low power headphone driver
 - Up to 31mW per channel output power at 1% THD+N into 16Ω at 1.8V
 - Ground Referenced
 - Low offset (+/- 1.2mV)
 - Pop and click suppression
 - Control sequencer for pop-minimised power-up/down
 - Single register write for default start-up sequence
- Microphone Interface
 - Single ended four stereo analogue input
 - Integrated low noise MICBIAS
 - Digital microphone interface
 - Programmable ALC / Limiter and Noise Gate
- Programmable Audio Enhancement DSP with Presets
 - Virtual Surround Sound
 - HD Bass
 - ReTune™
- Fixed Audio Processing DSP
 - 3D stereo widening
 - 5-band Parametric EQ
 - Dynamic range controller
 - Beep generator
- Two integrated PLLs enable clocking of full audio system
- Low Power Consumption
 - 7.7mW headphone playback
 - 8.3mW analogue record mode
- Low Supply Voltages
 - Analogue 1.7V to 2.0V (Speaker supply up to 5.5V)
 - Charge pump 1.7V to 2.0V
 - MIC bias amp supply 1.7V to 3.6V
 - Digital 1.62V to 2.0V
- 2-wire I2C and 3- or 4-wire SPI serial control interface
- Standard sample rates from 8kHz to 96kHz
- W-CSP, 3.6x3.9mm 49-pin

APPLICATIONS

- Portable gaming
- Mobile multimedia
- Voice recorders and Stereo DSC-Camcorder

BLOCK DIAGRAM

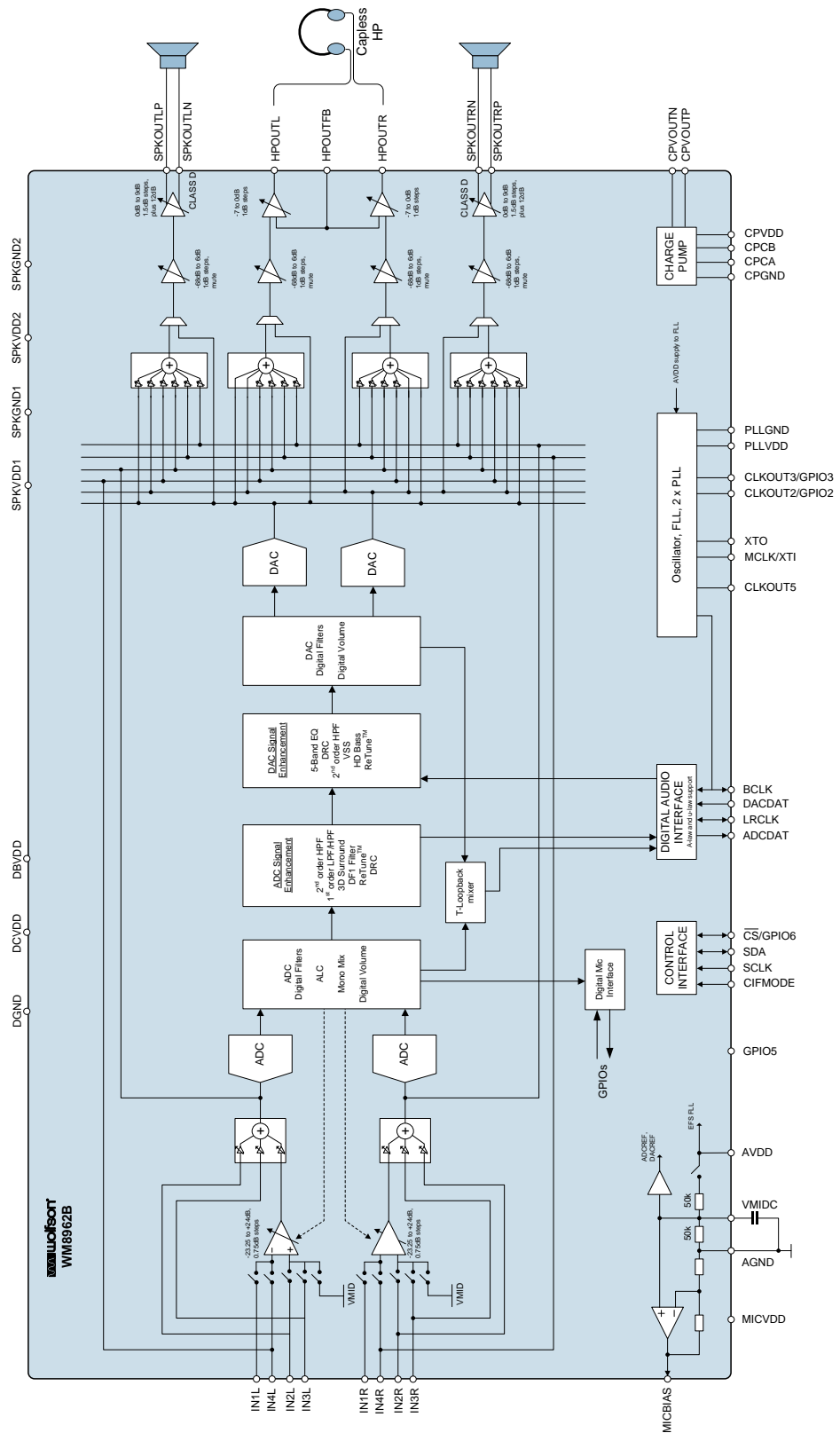

TABLE OF CONTENTS

DESCRIPTION	1
FEATURES	1
APPLICATIONS	1
BLOCK DIAGRAM	2
TABLE OF CONTENTS	3
PIN CONFIGURATION	7
ORDERING INFORMATION	7
PIN DESCRIPTION	8
ABSOLUTE MAXIMUM RATINGS	9
RECOMMENDED OPERATING CONDITIONS	9
ELECTRICAL CHARACTERISTICS	10
TERMINOLOGY.....	20
THERMAL CHARACTERISTICS	21
TYPICAL POWER CONSUMPTION	22
SIGNAL TIMING REQUIREMENTS	26
MASTER CLOCK.....	26
AUDIO INTERFACE TIMING	27
DIGITAL MICROPHONE (DMIC) INTERFACE TIMING	27
DIGITAL AUDIO INTERFACE - MASTER MODE	28
DIGITAL AUDIO INTERFACE - SLAVE MODE.....	29
DIGITAL AUDIO INTERFACE - TDM MODE.....	30
CONTROL INTERFACE TIMING	31
2-WIRE (I2C) CONTROL MODE	31
3-WIRE (SPI) CONTROL MODE.....	32
4-WIRE (SPI) CONTROL MODE.....	33
POWER ON RESET TIMING	34
DEVICE DESCRIPTION	37
INTRODUCTION.....	37
INPUT SIGNAL PATH.....	38
MICROPHONE INPUT CONNECTION	39
LINE INPUT CONNECTION.....	39
MICROPHONE BIAS CONTROL	40
MICBIAS CURRENT DETECT	40
MICBIAS CURRENT DETECT FILTERING.....	41
MICROPHONE HOOK SWITCH DETECTION.....	43
MULTIPLE PUSH BUTTON DETECTION	44
INPUT PGA ENABLE	45
INPUT PGA CONFIGURATION	46
INPUT PGA VOLUME CONTROL.....	47
INPUT MIXER ENABLE.....	49
INPUT MIXER CONFIGURATION AND VOLUME CONTROL.....	49
AUTOMATIC LEVEL CONTROL (ALC).....	52
LIMITER MODE.....	54
ALC GAIN CONTROL.....	56
ALC DYNAMIC CHARACTERISTICS.....	57
PEAK LIMITER	59
ALC NOISE GATE	60
ALC STATUS READBACK.....	64

DIGITAL MICROPHONE INTERFACE	65
ANALOGUE TO DIGITAL CONVERTER (ADC)	68
ADC CLOCKING CONTROL	68
ADC DIGITAL VOLUME CONTROL	69
ADC OVERSAMPLING RATIO (OSR)	71
ADC MONOMIX	71
DSP SIGNAL ENHANCEMENTS	72
ENABLE SEQUENCE - ENHANCEMENTS INITIALLY DISABLED	72
ENABLE / DISABLE SEQUENCE - ENHANCEMENTS INITIALLY ENABLED	73
DISABLE ALL SOUND ENHANCEMENTS SEQUENCE	74
UPDATE / READBACK SEQUENCE - ENHANCEMENTS INITIALLY ENABLED	75
UPDATE / READBACK SEQUENCE - ENHANCEMENTS INITIALLY DISABLED	76
ADC SIGNAL PATH ENHANCEMENTS	77
ADC SECOND ORDER HIGH-PASS FILTER	77
LOW-PASS / HIGH-PASS FILTER (LPF/HPF)	79
3D SURROUND	80
DF1 FILTER	83
ADC RETUNE™	85
DYNAMIC RANGE CONTROL (DRC)	86
DIGITAL MIXING	94
DIGITAL MIXING PATHS	94
DIGITAL SIDETONE	95
T-LOOPBACK	97
DAC SIGNAL PATH ENHANCEMENTS	99
5-BAND EQ	99
DYNAMIC RANGE CONTROL (DRC)	103
DAC SECOND ORDER HIGH-PASS FILTER	104
VIRTUAL SURROUND SOUND (VSS)	105
HD BASS	106
DAC RETUNE™	107
DIGITAL-TO-ANALOGUE CONVERTER (DAC)	108
DAC CLOCKING CONTROL	109
DAC DIGITAL VOLUME CONTROL	109
DAC SOFT MUTE AND UN-MUTE	111
DAC AUTO-MUTE	113
DAC MONO MIX	113
DAC DE-EMPHASIS	114
DAC OVERSAMPLING RATIO (OSR)	114
DIGITAL BEEP GENERATOR	115
OUTPUT SIGNAL PATH	116
OUTPUT SIGNAL PATHS ENABLE	117
SPEAKER OUTPUT PATHS	118
SPEAKER MIXER CONTROL	118
SPEAKER OUTPUT PGA CONTROL	121
SPEAKER OUTPUT CONFIGURATIONS	124
HEADPHONE OUTPUT PATHS	126
HEADPHONE SIGNAL PATHS ENABLE	126
HEADPHONE MIXER CONTROL	128
HEADPHONE OUTPUT PGA CONTROL	131
HEADPHONE OUTPUT CONFIGURATIONS	133
CHARGE PUMP	134
DC SERVO	135
DC SERVO ENABLE AND START-UP	135
DC SERVO ACTIVE MODES	137

REFERENCE VOLTAGES AND BIAS CONTROL.....	138
ANALOGUE REFERENCE AND MASTER BIAS	138
INPUT SIGNAL PATH BIAS CONTROL SETTINGS	139
OUTPUT SIGNAL PATH BIAS CONTROL SETTINGS	140
DIGITAL AUDIO INTERFACE	141
MASTER AND SLAVE MODE OPERATION	141
OPERATION WITH TDM.....	142
BCLK FREQUENCY	143
AUDIO DATA FORMATS (NORMAL MODE)	143
AUDIO DATA FORMATS (TDM MODE).....	145
DIGITAL AUDIO INTERFACE CONTROL.....	147
AUDIO INTERFACE TRI-STATE.....	148
BCLK AND LRCLK CONTROL.....	148
COMPANDING	149
LOOPBACK.....	151
CLOCKING AND SAMPLE RATES	152
SYSCLK CONTROL	153
AUTOMATIC CLOCKING CONFIGURATION	156
DSP, ADC, DAC CLOCK CONTROL.....	158
CLASS D, 256K, DC SERVO CLOCK CONTROL.....	159
OPCLK CONTROL	160
TOCLK, DBCLK CONTROL	160
BCLK AND LRCLK CONTROL.....	161
CONTROL INTERFACE CLOCKING	161
INTERNAL / EXTERNAL CLOCK GENERATION	162
START-UP OPTIONS FOR INTERNAL / EXTERNAL CLOCK GENERATION.....	163
INTERNAL OSCILLATOR CONTROL.....	164
CLKOUT CONTROL.....	166
FREQUENCY LOCKED LOOP (FLL)	168
FREE-RUNNING FLL CLOCK.....	172
EXAMPLE FLL CALCULATION.....	173
PHASE LOCKED LOOP (PLL)	174
EXAMPLE PLL CALCULATION	178
GENERAL PURPOSE INPUT/OUTPUT (GPIO).....	179
INTERRUPTS	183
CONTROL INTERFACE.....	188
SELECTION OF CONTROL INTERFACE MODE	188
2-WIRE (I2C) CONTROL MODE	189
3-WIRE (SPI) CONTROL MODE.....	192
4-WIRE (SPI) CONTROL MODE.....	193
CONTROL WRITE SEQUENCER.....	194
INITIATING A SEQUENCE.....	194
PROGRAMMING A SEQUENCE	195
DEFAULT SEQUENCES.....	198
THERMAL SHUTDOWN	202
SOFTWARE RESET AND CHIP ID.....	203
REGISTER MAP	204
REGISTER BITS BY ADDRESS	213
DIGITAL FILTER CHARACTERISTICS	278
DAC FILTER RESPONSES	279
ADC FILTER RESPONSES	281
ADC HIGH PASS FILTER RESPONSES	282

DE-EMPHASIS FILTER RESPONSES.....	283
APPLICATIONS INFORMATION	284
ANALOGUE INPUT PATHS	284
MICROPHONE BIAS CIRCUIT	284
CHARGE PUMP COMPONENTS	286
RECOMMENDED EXTERNAL COMPONENTS DIAGRAM.....	287
PCB LAYOUT CONSIDERATIONS	289
MIC DETECTION SEQUENCE USING MICBIAS CURRENT.....	290
PACKAGE DIMENSIONS.....	292
IMPORTANT NOTICE	293
REVISION HISTORY	294

PIN CONFIGURATION

ORDERING INFORMATION

ORDER CODE	TEMPERATURE RANGE	PACKAGE	MOISTURE SENSITIVITY LEVEL	PEAK SOLDERING TEMPERATURE
WM8962BECSN/R	-40°C to +85°C	49-ball CSP (3.6x3.9mm) (Pb-free, Tape and reel)	MSL1	260°C

Note:

Reel quantity = 5,000

PIN DESCRIPTION

PIN NO	NAME	TYPE	DESCRIPTION
A1	SPKOUTLP	Analogue Output	Left speaker positive output
A2	SPKVDD1	Supply	Supply for left speaker drivers
A3	MICVDD	Supply	Microphone bias amp supply
A4	MICBIAS	Reference	Microphone bias
A5	HPOUTR	Analogue Output	Right output (Line or headphone)
A6	CPVOUTP	Supply	Charge pump positive supply (powers HPOUTL, HPOUTR)
A7	CPVOUTN	Supply	Charge pump negative supply (powers HPOUTL, HPOUTR)
B1	SPKGND1	Supply	Ground for left speaker drivers
B2	SPKOUTRP	Analogue Output	Right speaker positive output
B3	SPKOUTLN	Analogue Output	Left speaker negative output
B4	HPOUTFB	Analogue Input	HPOUTL/R ground loop noise rejection feedback
B5	HPOUTL	Analogue Output	Left output (Line or headphone)
B6	CPCA	Analogue Input	Charge pump fly-back capacitor pin
B7	CPCB	Analogue Input	Charge pump fly-back capacitor pin
C1	SPKGND2	Supply	Ground for right speaker drivers
C2	SPKVDD2	Supply	Supply for right speaker drivers
C3	SPKOUTRN	Analogue Output	Right speaker negative output
C4	IN1L	Analogue Input	Left channel single-ended input 1
C5	VMIDC	Reference	Mid-rail voltage (AVDD/2) - (requires decoupling capacitor)
C6	CPVDD	Supply	Charge pump power supply
C7	CPGND	Supply	Charge pump ground (return path for CPVDD)
D1	DACDAT	Digital Input	DAC digital audio data
D2	ADCDAT	Digital Output	ADC digital audio data
D3	LRCLK	Digital Input / Output	Audio interface left / right clock
D4	IN1R	Analogue Input	Right channel single-ended input 1
D5	IN2L	Analogue Input	Left channel single-ended input 2
D6	AVDD	Supply	Analogue supply
D7	AGND	Supply	Analogue ground (return path for AVDD and MICVDD)
E1	BCLK	Digital Input / Output	Audio interface bit clock
E2	SDA	Digital Input / Output	Control interface data input / 2-wire acknowledge output
E3	CS/GPIO6	Digital Input / Output	CS input / Digital Microphone input / General purpose input / output
E4	CLKOUT2/GPIO2	Digital Output	PLL2 Clock output / General purpose input / output
E5	IN2R	Analogue Input	Right channel single-ended input 2
E6	IN4L	Analogue Input	Left channel single-ended input 4
E7	IN4R	Analogue Input	Right channel single-ended input 4
F1	SCLK	Digital Input	Control interface clock input
F2	CIFMODE	Digital Input	Selects 2-wire or 3 / 4-wire control wire interface
F3	DGND	Supply	Digital ground
F4	CLKOUT3/GPIO3	Digital Output	PLL3 / FLL Clock output / GPIO
F5	IN3L	Analogue Input	Left channel single-ended input 3
F6	IN3R	Analogue Input	Right channel single-ended input 3
F7	XTO	Analogue Output	xtal output
G1	GPIO5	Digital Input / Output	Digital Microphone Input / General purpose input / output Important: See page 179 for start-up requirements.
G2	DCVDD	Supply	Digital Core Supply
G3	DBVDD	Supply	Digital Buffer Supply
G4	PLLVD	Supply	PLL Supply
G5	PLLGND	Supply	PLL Ground
G6	CLKOUT5	Analogue Output	FLL / Oscillator Clock output
G7	MCLK / XT1	Digital Input	Master clock input / xtal input

ABSOLUTE MAXIMUM RATINGS

Absolute Maximum Ratings are stress ratings only. Permanent damage to the device may be caused by continuously operating at or beyond these limits. Device functional operating limits and guaranteed performance specifications are given under Electrical Characteristics at the test conditions specified.



ESD Sensitive Device. This device is manufactured on a CMOS process. It is therefore generically susceptible to damage from excessive static voltages. Proper ESD precautions must be taken during handling and storage of this device.

Cirrus tests its package types according to IPC/JEDEC J-STD-020 for Moisture Sensitivity to determine acceptable storage conditions prior to surface mount assembly. These levels are:

MSL1 = unlimited floor life at <30°C / 85% Relative Humidity. Not normally stored in moisture barrier bag.

MSL2 = out of bag storage for 1 year at <30°C / 60% Relative Humidity. Supplied in moisture barrier bag.

MSL3 = out of bag storage for 168 hours at <30°C / 60% Relative Humidity. Supplied in moisture barrier bag.

The Moisture Sensitivity Level for each package type is specified in Ordering Information.

CONDITION	MIN	MAX
DCVDD, AVDD, PLLVDD	-0.3V	+2.5V
MICVDD, DBVDD	-0.3V	+4.5V
SPKVDD1, SPKVDD2	-0.3V	+7.0V
CPVDD	-0.3V	+2.2V
Voltage range digital inputs	DGND -0.3V	DBVDD +0.3V
Voltage range analogue inputs	AGND -0.3V	AVDD +0.3V
Voltage range analogue outputs (HPOUTL, HPOUTR)	-CPVDD-0.3V	+CPVDD+0.3V
Temperature Range, T _A	-40°C	+85°C
Junction Temperature, T _J	-40°C	+150°C
Storage temperature after soldering	-65°C	+150°C

Notes:

1. Analogue, digital and speaker grounds must always be within 0.3V of each other.
2. All digital and analogue supplies are completely independent from each other (i.e. not internally connected).
3. AVDD must be less than or equal to MICVDD.
4. AVDD must be less than or equal to SPKVDD1 and SPKVDD2.

RECOMMENDED OPERATING CONDITIONS

PARAMETER	SYMBOL	MIN	TYP	MAX	UNIT
Digital core supply range	DCVDD	1.62	1.8	2.0	V
Digital buffer supply range	DBVDD	1.62	1.8	3.6	V
Microphone bias supply range	MICVDD	1.7	2.5	3.6	V
Analogue supplies range	AVDD	1.7	1.8	2.0	V
PLL supply range	PLLVDD	1.7	1.8	2.0	V
Charge pump supply range (1.8V supply operation)	CPVDD	1.7	1.8	2.0	V
Speaker supply range	SPKVDD1, SPKVDD2	1.7	5.0	5.5	V
Ground	DGND, AGND, CPGND, SPKGND1, SPKGND2, PLLGND		0		V
Operating temperature range	T _A	-40		85	°C
Operating junction temperature	T _J	-40		85	°C

Notes:

1. SPKVDD1 and SPKVDD2 must be high enough to support the peak output voltage when using CLASSD_VOL function, to avoid output waveform clipping. Peak output voltage is AVDD*CLASSD_VOL.
2. The AGND and PLLGND pins must be tied together as close as possible to the WM8962B.
3. The WM8962B can operate with PLLVDD tied to 0V; device power consumption may be reduced, but the crystal oscillator, PLLs and CLKOUT functions will not be supported.

ELECTRICAL CHARACTERISTICS
Test Conditions

MICVDD = DCVDD = DBVDD = CPVDD = AVDD = PLLVDD = 1.8V, SPKVDD1 = SPKVDD2 = 5V.

 T_A = +25°C, 1kHz signal, f_s = 48kHz, PGA gain = 0dB, 24-bit audio data unless otherwise stated.

PARAMETER	SYMBOL	TEST CONDITIONS	MIN	TYP	MAX	UNIT
Analogue Inputs (IN1L, IN1R, IN4L, IN4R) to Input PGA						
Full-scale Input Signal Level – note this changes in proportion to AVDD	V _{INFS}	Single-ended PGA input		500 -6.02		mVrms dBV
Input resistance		+24dB PGA gain		3.6		kΩ
		0dB PGA gain		30.0		
		-23.25dB PGA gain		56.5		
Input capacitance	C _{in}			65		pF
Analogue Inputs (IN2L, IN2R, IN3L, IN3R) to Input PGA						
Full-scale Input Signal Level – note this changes in proportion to AVDD	V _{INFS}	Single-ended PGA input		500 -6.02		mVrms dBV
Input resistance		All gain settings		60		kΩ
Input Programmable Gain Amplifier (PGA)						
Minimum programmable gain				-23.25		dB
Maximum programmable gain				24		dB
Programmable Gain Step Size		Guaranteed monotonic		0.75		dB
PGA Noise (referred to input) (A-weighted)		IN1 and IN4		-113		dBV
PGA Noise (referred to input) (A-weighted)		IN2 and IN3		-113		dBV
Mute Attenuation				100		dB
Selectable Input Gain Boost (From Input PGA)						
Gain Boost Steps		Input from PGA		0, 6, 13, 18, 20, 24, 27, 29		dB
Mute Attenuation				95		dB
Selectable Input Gain to ADC Mixer (From IN2, IN3)						
Gain Boost Steps		Input from IN2 / IN3		-12, -9, -6, -3, 0, 3, 6		dB
Mute Attenuation				95		dB

Test Conditions

MICVDD = DCVDD = DBVDD = CPVDD = AVDD = PLLVDD = 1.8V, SPKVDD1 = SPKVDD2 = 5V.

 T_A = +25°C, 1kHz signal, fs = 48kHz, PGA gain = 0dB, 24-bit audio data unless otherwise stated.

PARAMETER	SYMBOL	TEST CONDITIONS	MIN	TYP	MAX	UNIT
Analogue Inputs (IN1L, IN1R) to ADC out via Input PGA and Input Gain Boost						
Signal to Noise Ratio (A-weighted)	SNR	ADC_HP=0 MIXIN_BIAS=100 INPGA_BIAS=100		91		dB
Total Harmonic Distortion Plus Noise (-1dBFS input)	THD+N	'Option 1' (low power) bias settings - see Note 2.		-70		dB
Signal to Noise Ratio (A-weighted)	SNR	ADC_HP=0 MIXIN_BIAS=011 INPGA_BIAS=100		91		dB
Total Harmonic Distortion Plus Noise (-1dBFS input)	THD+N	'Option 2' bias settings - see Note 2.		-75		dB
Signal to Noise Ratio (A-weighted)	SNR	ADC_HP=0 MIXIN_BIAS=000 INPGA_BIAS=100	81	91		dB
Total Harmonic Distortion Plus Noise (-1dBFS input)	THD+N	'Option 3' bias settings - see Note 2.		-82	-72	dB
Signal to Noise Ratio (A-weighted)	SNR	ADC_HP=1 MIXIN_BIAS=000 INPGA_BIAS=000		93		dB
Total Harmonic Distortion Plus Noise (-1dBFS input)	THD+N	Option 4' (high performance) bias settings - see Note 2.		-82		dB
ADC Channel Separation		1kHz		95		dB
		10kHz		97		
PSRR (AVDD)		100mV(peak-peak) 1kHz		60		dB
		100mV(peak-peak) 20kHz		40		
Channel Matching		1kHz signal		+/-0.5		dB

Test Conditions

MICVDD = DCVDD = DBVDD = CPVDD = AVDD = PLLVDD = 1.8V, SPKVDD1 = SPKVDD2 = 5V.

 T_A = +25°C, 1kHz signal, f_s = 48kHz, PGA gain = 0dB, 24-bit audio data unless otherwise stated.

PARAMETER	SYMBOL	TEST CONDITIONS	MIN	TYP	MAX	UNIT
Analogue Inputs (IN2L, IN2R) to ADC out via Input Gain (Input PGA Bypassed)						
Signal to Noise Ratio (A-weighted)	SNR	ADC_HP=0 MIXIN_BIAS=100 INPGA_BIAS=100		91		dB
Total Harmonic Distortion Plus Noise (-1dBFS input)	THD+N	'Option 1' (low power) bias settings - see Note 2.		-70		dB
Signal to Noise Ratio (A-weighted)	SNR	ADC_HP=0 MIXIN_BIAS=011 INPGA_BIAS=100		91		dB
Total Harmonic Distortion Plus Noise (-1dBFS input)	THD+N	'Option 2' bias settings - see Note 2.		-75		dB
Signal to Noise Ratio (A-weighted)	SNR	ADC_HP=0 MIXIN_BIAS=000 INPGA_BIAS=100		91		dB
Total Harmonic Distortion Plus Noise (-1dBFS input)	THD+N	'Option 3' bias settings - see Note 2.		-85		dB
Signal to Noise Ratio (A-weighted)	SNR	ADC_HP=1 MIXIN_BIAS=000 INPGA_BIAS=000		94		dB
Total Harmonic Distortion Plus Noise (-1dBFS input)	THD+N	'Option 4' (high performance) bias settings - see Note 2.		-85		dB
ADC Channel Separation		1kHz		95		dB
		10kHz		87		
PSRR (AVDD)		100mV(peak-peak) 1kHz		60		dB
		100mV(peak-peak) 20kHz		40		
Analogue Inputs (IN4L, IN4R) to HPOUTL/R (used as Line output) with 10kΩ / 50pF load: Low Power headphone playback mode (Note 3)						
Input Resistance		+6dB PGA gain		10		kΩ
		0dB PGA gain		17		
		-15dB PGA gain		80		
Signal to Noise Ratio (A-weighted)	SNR			97		dB
Total Harmonic Distortion Plus Noise	THD+N	10kΩ, 50pF load		-80		dB

Test Conditions

MICVDD = DCVDD = DBVDD = CPVDD = AVDD = PLLVDD = 1.8V, SPKVDD1 = SPKVDD2 = 5V.

 T_A = +25°C, 1kHz signal, f_s = 48kHz, PGA gain = 0dB, 24-bit audio data unless otherwise stated.

PARAMETER	SYMBOL	TEST CONDITIONS	MIN	TYP	MAX	UNIT
ADC Input Path Crosstalk						
IN1 / IN4 ADC input path crosstalk		1kHz		-98		dB
		10kHz		-79		
IN2 / IN3 ADC input path crosstalk		1kHz		-85		dB
		10kHz		-65		
IN2 / IN4 ADC input path crosstalk		1kHz		-90		dB
		10kHz		-69		
IN3 / IN4 ADC input path crosstalk		1kHz		-75		dB
		10kHz		-55		
The ADC path is enabled from one input pin; -6dBV test signal applied to the other input; crosstalk measured at ADC output. The test is repeated with the two input pins swapped; the crosstalk figure is the worst case of the two measurements.						

Test Conditions

MICVDD = DCVDD = DBVDD = CPVDD = AVDD = PLLVDD = 1.8V, SPKVDD1 = SPKVDD2 = 5V.

 T_A = +25°C, 1kHz signal, fs = 48kHz, PGA gain = 0dB, 24-bit audio data unless otherwise stated.

PARAMETER	SYMBOL	TEST CONDITIONS	MIN	TYP	MAX	UNIT
HPOUTL/R_VOL						
Minimum programmable gain				-68		dB
Maximum programmable gain				6		dB
Volume Gain Step Size		Guaranteed monotonic		1		dB
Mute Attenuation				94		dB
HP1L/R_VOL						
Minimum programmable gain				-7		dB
Maximum programmable gain				0		dB
Volume Gain Step Size		Guaranteed monotonic		1		dB
DAC to HPOUTL/R (used as Line output) with 10kΩ / 50pF load: Low Power headphone playback mode (Note 3)						
Full scale output voltage		HPOUTL/R_VOL = 0dB		0.96		V _{rms}
Signal to Noise Ratio (A-weighted)	SNR		87	97		dB
Total Harmonic Distortion Plus Noise	THD+N	10kΩ load		-84	-74	dB
Channel Separation		1kHz full scale signal		93		dB
		10kHz full scale signal		86		
PSRR (AVDD)		100mV(peak-peak) 1kHz		70		dB
		100mV(peak-peak) 20kHz		65		
DC offset		DC servo is enabled	0		+/-1.2	mV
DAC to HPOUTL/R (used as Line output) with 10kΩ / 50pF load: High Performance headphone playback mode (Note 3)						
Signal to Noise Ratio (A-weighted)	SNR		87	98		dB
Total Harmonic Distortion Plus Noise	THD+N	10kΩ load		-84	-74	dB

Test Conditions

MICVDD = DCVDD = DBVDD = CPVDD = AVDD = PLLVDD = 1.8V, SPKVDD1 = SPKVDD2 = 5V.

 T_A = +25°C, 1kHz signal, f_s = 48kHz, PGA gain = 0dB, 24-bit audio data unless otherwise stated.

PARAMETER	SYMBOL	TEST CONDITIONS	MIN	TYP	MAX	UNIT
DAC to HPOUTL/R with headphone load: Low Power headphone playback mode (Note 3)						
Output Power at 1% THD+N	P _O	R _L =32Ω		26		mW
		R _L =16Ω		31		
Total Harmonic Distortion Plus Noise	THD+N	R _L =32Ω, P _O =2mW		-79 0.011		dB %
		R _L =32Ω, P _O =3.5mW		-79 0.011		
		R _L =32Ω, P _O =12mW		-78 0.013		
		R _L =16Ω, P _O =2mW		-81 0.0089		
		R _L =16Ω, P _O =22mW		-80 0.010		
Output Noise Level				-97	-87	dBV
DC offset		DC servo is enabled	0		+/-1.2	mV
Channel Separation		1kHz test signal, R _L =16Ω, P _O =22mW		95		dB
		10kHz test signal, R _L =16Ω, P _O =22mW		84		
DAC to HPOUTL/R with headphone load: High Performance playback mode (Note 3)						
Total Harmonic Distortion Plus Noise	THD+N	R _L =32Ω, P _O =12mW		-84 0.0063		dB %
		R _L =16Ω, P _O =22mW		-81 0.0089		
Output Noise Level				-98	-87	dBV

Test Conditions

MICVDD = DCVDD = DBVDD = CPVDD = AVDD = PLLVDD = 1.8V, SPKVDD1 = SPKVDD2 = 5V.

T_A = +25°C, 1kHz signal, f_s = 48kHz, PGA gain = 0dB, 24-bit audio data unless otherwise stated.

PARAMETER	SYMBOL	TEST CONDITIONS	MIN	TYP	MAX	UNIT
SPKOUTL/R_VOL						
Minimum programmable gain				-68		dB
Maximum programmable gain				6		dB
Volume Gain Step Size		Guaranteed monotonic		1		dB
Mute Attenuation				92		dB
DAC to Stereo Speaker Outputs (DAC to SPKOUTLP, SPKOUTLN, SPKOUTRP, SPKOUTRN with 8Ω + 22μH bridge tied load)						
Output Power	P _O	1% THD+N, R _L = 8Ω, SPKVDD1=SPKVDD2=5.5V		1.26		W
		1% THD+N, R _L = 8Ω, SPKVDD1=SPKVDD2=1.7V		0.08		
Total Harmonic Distortion Plus Noise	THD+N	P _O =200mW, R _L = 8Ω, SPKVDD1=SPKVDD2=3.3V		-68 0.040		dB %
		P _O =320mW, R _L = 8Ω, SPKVDD1=SPKVDD2=3.3V		-72 0.025		
		P _O =320mW, R _L = 8Ω, SPKVDD1=SPKVDD2=5V		-67 0.045	-55	
		P _O =1W, R _L = 8Ω, SPKVDD1=SPKVDD2=5V, CLASSD_VOL=110 DACL/R_VOL=C1h		-61 0.089		
Signal to Noise Ratio (A-weighted) (DAC to speaker outputs)	SNR	SPKVDD1=SPKVDD2=3.3V, R _L = 8Ω, Output signal =2.0Vrms		90		dB
		SPKVDD1=SPKVDD2=5V, R _L = 8Ω, Output signal=2.8Vrms	83	93		
PSRR (SPKVDD1/SPKVDD2)	PSRR	100mV(peak-peak) 217Hz		78		dB
		100mV(peak-peak) 1kHz		78		
DAC to Stereo Speaker Outputs (DAC to SPKOUTLP, SPKOUTLN, SPKOUTRP, SPKOUTRN with 4Ω + 22μH bridge tied load)						
Output Power	P _O	1% THD+N, R _L = 4Ω, SPKVDD1=SPKVDD2=5V		1.75		W
		10% THD+N, R _L = 4Ω, SPKVDD1=SPKVDD2=5V		2.20		
Total Harmonic Distortion Plus Noise	THD+N	P _O =1W, R _L = 4Ω, SPKVDD1=SPKVDD2=5V		-67 0.045		dB %
		P _O =2W, R _L = 4Ω, SPKVDD1=SPKVDD2=5V		-25 5.5		
Signal to Noise Ratio (A-weighted) (DAC to speaker outputs)	SNR	SPKVDD1=SPKVDD2=3.3V, R _L = 4Ω, Output signal=2.0Vrms		90		dB
		SPKVDD1=SPKVDD2=5V, R _L = 4Ω, Output signal=2.8Vrms		93		

Test Conditions

MICVDD = DCVDD = DBVDD = CPVDD = AVDD = PLLVDD = 1.8V, SPKVDD1 = SPKVDD2 = 5V.

T_A = +25°C, 1kHz signal, f_s = 48kHz, PGA gain = 0dB, 24-bit audio data unless otherwise stated.

PARAMETER	SYMBOL	TEST CONDITIONS	MIN	TYP	MAX	UNIT
DAC to Mono Speaker Output (DAC to SPKOUTLP/RP, SPKOUTLN/RN with 4Ω + 22μH bridge tied load, SPK_MONO=1)						
Output Power	P _O	1% THD+N, R _L = 4Ω, SPKVDD1=SPKVDD2=5.5V		2.45		W
		1% THD+N, R _L = 4Ω, SPKVDD1=SPKVDD2=1.7V		0.15		
Total Harmonic Distortion Plus Noise	THD+N	P _O =400mW, R _L = 4Ω, SPKVDD1=SPKVDD2=3.3V		-64 0.063		dB %
		P _O =640mW, R _L = 4Ω, SPKVDD1=SPKVDD2=3.3V		-63 0.071		
		P _O =640mW, R _L = 4Ω, SPKVDD1=SPKVDD2=5V		-67 0.044		
		P _O =2W, R _L = 4Ω, SPKVDD1=SPKVDD2=5V, CLASSD_VOL=110 DACL/R_VOL=C1h		-61 0.089		
Signal to Noise Ratio (A-weighted) (DAC to speaker outputs)	SNR	SPKVDD1=SPKVDD2=3.3V, R _L = 4Ω, Output signal=2.0Vrms		90		dB
		SPKVDD1=SPKVDD2=5V, R _L = 4Ω, Output signal=2.8Vrms		93		

Test Conditions

MICVDD = DCVDD = DBVDD = CPVDD = AVDD = PLLVDD = 1.8V, SPKVDD1 = SPKVDD2 = 5V.

T_A = +25°C, 1kHz signal, f_s = 48kHz, PGA gain = 0dB, 24-bit audio data unless otherwise stated.

PARAMETER	SYMBOL	TEST CONDITIONS	MIN	TYP	MAX	UNIT
Analogue Reference Levels						
Mid-rail Reference Voltage	VMIDC		-3%	AVDD/2	+3%	V
Microphone Bias						
Bias Voltage (Note that MICVDD must be at least 300mV higher than V _{MICBIAS})	V _{MICBIAS}	MICVDD=2.5V, 2mA load current, MICBIAS_EVR=00, MICBIAS_LVL=0	-4%	0.828 × AVDD	+4%	V
		MICVDD=2.5V, 2mA load current, MICBIAS_EVR=00, MICBIAS_LVL=1	-4%	1.156 × AVDD	+4%	
		MICVDD=3.3V, 2mA load current, MICBIAS_EVR=10		1.33 × AVDD		
		MICVDD=3.3V, 2mA load current, MICBIAS_EVR=01		1.59 × AVDD		
PSRR (MICVDD)	PSRR	100mV (peak-peak) 1kHz, MICBIAS_EVR=00, MICBIAS_LVL=1		74		dB
PSRR (AVDD)	PSRR	100mV (peak-peak) 1kHz, MICBIAS_EVR=00, MICBIAS_LVL=1		52		dB
Maximum Bias Current Source	I _{MICBIAS}			2		mA
Output Noise spectral density @ 1kHz	V _{st}	MICBIAS_EVR=00, MICBIAS_LVL=0		63		nV/√Hz
		MICBIAS_EVR=00, MICBIAS_LVL=1		85		
		MICBIAS_EVR=10		96		
		MICBIAS_EVR=01		116		
MICBIAS Current Detect Function (see Note 1)						
Current Detect Threshold		MICDET_THR = 000	38	64	90	μA
		MICDET_THR = 001	-25%	166	+25%	
		MICDET_THR = 010	-20%	375	+20%	
		MICDET_THR = 011	-20%	475	+20%	
		MICDET_THR = 100	-20%	575	+20%	
		MICDET_THR = 101	-20%	680	+20%	
		MICDET_THR = 110	-20%	885	+20%	
		MICDET_THR = 111	-20%	990	+20%	
Delay Time for Current Detect Interrupt	t _{DET}			1.6		ms
MICBIAS Short Circuit (Hook Switch) Detect Function (see Note 1)						
Short Circuit Detect Threshold		MICSHORT_THR = 00	-18%	515	+18%	μA
		MICSHORT_THR = 01	-15%	680	+15%	
		MICSHORT_THR = 10	-15%	1050	+15%	
		MICSHORT_THR = 11	-15%	1215	+15%	
Delay Time for Short Circuit Detect Interrupt	t _{SHORT}			47		ms

Test Conditions

MICVDD = DCVDD = DBVDD = CPVDD = AVDD = PLLVDD = 1.8V, SPKVDD1 = SPKVDD2 = 5V.

T_A = +25°C, 1kHz signal, fs = 48kHz, PGA gain = 0dB, 24-bit audio data unless otherwise stated.

PARAMETER	SYMBOL	TEST CONDITIONS	MIN	TYP	MAX	UNIT
Charge Pump						
Maximum Charge Pump switching frequency	CP _{FREQ}			1		MHz
Flyback capacitor (between CPCA and CPCB pins)	C _{FB}	at 2V	1			μF
VPOS capacitor		at 2V	2			μF
VNEG capacitor		at 2V	2			μF
Charge pump start-up time				190		μs
Crystal Oscillator						
External crystal frequency				24		MHz
Oscillator load capacitance		XTI and XTO Pins		10.5		pF
Start-up time		measured from time when: PLLVDD ≥ 1.7V, AVDD ≥ 1.7V and DVDD ≥ 1.62V, until crystal output is stable and in specification.		1.5		ms
Phase Locked Loops (PLLs)						
Output frequency	F _{OUT}		22.5		50	MHz
Output duty cycle			40	50	60	%
Start-up time (including Crystal Oscillator start-up time)		measured from time when: PLLVDD ≥ 1.7V, AVDD ≥ 1.7V and DVDD ≥ 1.62V, until PLL outputs are stable and in specification.		1.5		ms
Frequency synthesis error				0		ppm
Absolute clock period jitter (peak)		Input Clock = 24MHz, 5pF load		500		ps
Short term jitter (peak, cycle to cycle)		N=1, 1000 samples, Input Clock = 24MHz, 5pF load. (see Note 4)		150		ps
Long term jitter (peak)		N=1000, 1000 samples, Input Clock = 24MHz, 5pF load. (see Note 4)		500		ps
MCLK / XTI input frequency range			14		40	MHz
Frequency Locked Loop (FLL)						
Input frequency	F _{REF}	FLL_REFCLK_DIV = 00	0.032		13.5	MHz
		FLL_REFCLK_DIV = 01	0.064		27	
		FLL_REFCLK_DIV = 10	0.128		36.864	
Output frequency	F _{OUT}		1.875		50	MHz
Start-Up time		VMID enabled; measured from FLL_ENA=1 to clock signal present on CLKOUTn.		220		μs
Frequency synthesis error				0		ppm
Start-Up time (free-running mode)		VMID enabled; measured from FLL_ENA=1 to clock signal present on CLKOUTn.		0.75		μs
Frequency accuracy (free-running mode)		Reference clock supplied initially		+/-10		%
		No reference clock provided		+/-30		%

Test Conditions

MICVDD = DCVDD = DBVDD = CPVDD = AVDD = PLLVDD = 1.8V, SPKVDD1 = SPKVDD2 = 5V.

T_A = +25°C, 1kHz signal, fs = 48kHz, PGA gain = 0dB, 24-bit audio data unless otherwise stated.

PARAMETER	SYMBOL	TEST CONDITIONS	MIN	TYP	MAX	UNIT
Digital Input / Output						
Input HIGH Level	V _{IH}		0.7×DBVDD			V
Input LOW Level	V _{IL}				0.3×DBVDD	V
Output HIGH Level	V _{OH}	I _{OH} =1mA	0.9×DBVDD			V
Output LOW Level	V _{OL}	I _{OL} =-1mA			0.1×DBVDD	V
Input capacitance				15		pF
Input leakage			-0.9		0.9	μA
CLKOUTn output impedance				160		Ω
Current Consumption						
AVDD	I _{AVDD}	OFF: power applied, all clocks stopped, thermal shut-down enabled		40	75	μA
DCVDD	I _{DCVDD}			3	25	μA
DBVDD	I _{DBVDD}			0	10	μA
CPVDD	I _{CPVDD}			0.5	10	μA
SPKVDD1	I _{SPKVDD1}			1	5	μA
SPKVDD2	I _{SPKVDD2}			1	5	μA
MICVDD	I _{MICVDD}			0.2	5	μA
PLLVDD	I _{PLLVDD1}		7	30	μA	
MICVDD	I _{MICVDD}	SPKVDD1=SPKVDD2=5V, MICVDD=2.5V, All other supplies disconnected		0.2	5	μA
SPKVDD1	I _{SPKVDD1}			0.2	5	μA
SPKVDD2	I _{SPKVDD2}			0.2	5	μA
MICVDD	I _{MICVDD}	SPKVDD1=SPKVDD2=5V, MICVDD=2.5V, All other supplies 0V		0.2	5	μA
SPKVDD1	I _{SPKVDD1}			0.2	5	μA
SPKVDD2	I _{SPKVDD2}			0.2	5	μA

Note:

1. If AVDD ≠ 1.8, current threshold values should be multiplied by (AVDD/1.8)
2. Four different bias configurations are supported for ADC input paths; these are defined in the “Reference Voltages and Bias Control” section.
3. Two different bias configurations are supported for the DAC / Headphone output paths; these are defined in the “Reference Voltages and Bias Control” section.
4. N = number of clock periods in one sample.

TERMINOLOGY

1. Signal-to-Noise Ratio (dB) – SNR is a measure of the difference in level between the maximum full scale output signal and the output with no input signal applied.
2. Total Harmonic Distortion (dB) – THD is the level of the rms value of the sum of harmonic distortion products relative to the amplitude of the measured output signal.
3. Total Harmonic Distortion plus Noise (dB) – THD+N is the level of the rms value of the sum of harmonic distortion products plus noise in the specified bandwidth relative to the amplitude of the measured output signal.
4. Channel Separation (L/R) (dB) – left-to-right and right-to-left channel separation is the measured signal level in the idle channel at the test signal frequency relative to the signal level at the output of the active channel. The active channel is configured and supplied with an appropriate input signal to drive a full scale output, with signal measured at the output of the associated idle channel.
5. Mute Attenuation – This is a measure of the difference in level between the full scale output signal and the output with mute applied.
6. All performance measurements carried out with 20kHz low pass filter, and where noted an A-weighted filter. Failure to use such a filter will result in higher THD and lower SNR readings than are found in the Electrical Characteristics. The low pass filter removes out of band noise; although it is not audible it may affect dynamic specification values.

THERMAL CHARACTERISTICS

The WM8962B thermal performance is characterised by the Θ_{JA} and Θ_{JB} parameters, as noted below.

Note that the thermal characteristics are based upon simulations in accordance with the JEDEC thermal testing standards, JESD51-9. These test conditions may be very different to the application conditions, so these parameters should be used with caution.

Theta-JA (Θ_{JA}) is the junction-to-air thermal resistance. It is determined by the following equation:

$$\Theta_{JA} = \frac{T_J - T_A}{P_A}$$

where

T_J = Junction temperature (the maximum temperature on the die)

T_A = Ambient temperature (the temperature of the surrounding environment)

P_A = Power dissipated from the device to the surrounding air

Theta-JB (Θ_{JB}) is the junction-to-board thermal resistance. It is determined by the following equation:

$$\Theta_{JB} = \frac{T_J - T_B}{P_B}$$

where

T_J = Junction temperature (the maximum temperature on the die)

T_B = Board temperature (the temperature of the printed circuit board)

P_B = Power dissipated from the device to the circuit board

See "Recommended Operating Conditions" for the recommended T_J and T_A operating limits.

PARAMETER	SYMBOL	TYP	UNIT
Thermal resistance (Theta-JA)	Θ_{JA}	50	°C/W
Thermal resistance (Theta-JB)	Θ_{JB}	20	°C/W

TYPICAL POWER CONSUMPTION

Analogue Input (IN1L, IN1R) to ADC out via Input PGA and Input Gain boost								
Quiescent input, default register conditions unless otherwise stated. MCLK = 12.288MHz, fs = 48kHz, MCLK rate = 256fs, 24-bit I2S, Slave mode, INL_ENA = 1, INR_ENA = 1, INPGAL_MUTE = 0, INPGAR_MUTE = 0, ADCL_ENA = 1, ADCR_ENA = 1 VMID_SEL = 01, BIAS_ENA = 1 See "Reference Voltages and Bias Control" for details of the bias configuration registers.								
	DCVDD 1.8V	DBVDD 1.8V	MICVDD 2.5V	AVDD 1.8V	PLLVDD 1.8V	CPVDD 1.8V	SPKVDD 5.0V	TOTAL
Quiescent input, Option 1 bias settings	2.4mA	0.0mA	0.0mA	2.5mA	0.0mA	0.0mA	0.0mA	8.8mW
Quiescent input, Option 2 bias settings	2.4mA	0.0mA	0.0mA	2.7mA	0.0mA	0.0mA	0.0mA	9.2mW
Quiescent input, Option 3 bias settings (default)	2.4mA	0.0mA	0.0mA	3.3mA	0.0mA	0.0mA	0.0mA	10.3mW
Quiescent input, Option 4 bias settings	2.6mA	0.0mA	0.0mA	5.4mA	0.0mA	0.0mA	0.0mA	14.4mW
-1dBFS ADC output	2.4mA	0.0mA	0.0mA	3.3mA	0.0mA	0.0mA	0.0mA	10.4mW
MICBIAS enabled	2.4mA	0.0mA	0.4mA	3.3mA	0.0mA	0.0mA	0.0mA	11.3mW
Quiescent input, fs = 8kHz, MCLK = 2.048MHz	0.3mA	0.0mA	0.0mA	3.0mA	0.0mA	0.0mA	0.0mA	6.0mW
Quiescent input, fs = 96kHz, MCLK = 24.576MHz	4.1mA	0.0mA	0.0mA	3.3mA	0.0mA	0.0mA	0.0mA	13.3mW
Quiescent input, fs = 48kHz, MCLK = 24.576MHz, MCLK = 512fs, DSP Sound Enhancement enabled	14.5mA	0.2mA	0.0mA	3.2mA	0.0mA	0.0mA	0.0mA	32.4mW

Analogue Input (IN2L, IN2R) to ADC out via Input PGA and Input Gain boost

Quiescent input, default register conditions unless otherwise stated.
MCLK = 12.288MHz, fs = 48kHz, MCLK rate = 256fs, 24-bit I2S, Slave mode,
MIXINL_ENA = 1, MIXINR_ENA = 1, IN2L_TO_MIXINL = 1, IN2R_TO_MIXINR = 1,
ADCL_ENA = 1, ADCR_ENA = 1,
VMID_SEL = 01, BIAS_ENA = 1.
See "Reference Voltages and Bias Control" for details of the bias configuration registers.

	DCVDD 1.8V	DBVDD 1.8V	MICVDD 2.5V	AVDD 1.8V	PLLVDD 1.8V	CPVDD 1.8V	SPKVDD 5.0V	TOTAL
Quiescent input, Option 1 bias settings	2.4mA	0.0mA	0.0mA	2.2mA	0.0mA	0.0mA	0.0mA	8.3mW
Quiescent input, Option 2 bias settings	2.4mA	0.0mA	0.0mA	2.4mA	0.0mA	0.0mA	0.0mA	8.7mW
Quiescent input, Option 3 bias settings (default)	2.4mA	0.0mA	0.0mA	3.0mA	0.0mA	0.0mA	0.0mA	9.8mW
Quiescent input, Option 4 bias settings	2.6mA	0.0mA	0.0mA	4.5mA	0.0mA	0.0mA	0.0mA	12.9mW
-1dBFS ADC output	2.4mA	0.0mA	0.0mA	3.0mA	0.0mA	0.0mA	0.0mA	9.9mW
MICBIAS enabled	2.4mA	0.0mA	0.4mA	3.0mA	0.0mA	0.0mA	0.0mA	10.7mW
Quiescent input, fs = 8kHz, MCLK = 2.048MHz	0.3mA	0.0mA	0.0mA	2.7mA	0.0mA	0.0mA	0.0mA	5.4mW
Quiescent input, fs = 96kHz, MCLK = 24.576MHz	4.1mA	0.0mA	0.0mA	3.0mA	0.0mA	0.0mA	0.0mA	12.8mW
Quiescent input, fs = 48kHz, MCLK = 24.576MHz, MCLK = 512fs, DSP Sound Enhancement enabled	14.5mA	0.2mA	0.0mA	3.0mA	0.0mA	0.0mA	0.0mA	32.0mW

Stereo DAC Playback to Headphone (HPOUTL, HPOUTR) - Low Power headphone playback mode, 16Ω load.

Default register conditions unless otherwise stated.
Default DAC to Headphone Power Up sequence completed.
CP_DYN_PWR = 1
MCLK = 12.288MHz, fs = 48kHz, MCLK rate = 256fs, 24-bit I2S, Slave mode,
Input signal level = 0dBFS, HP1x_VOL = 111b (0dB),
Note that Low Power headphone playback mode is selected by default.

	DCVDD 1.8V	DBVDD 1.8V	MICVDD 2.5V	AVDD 1.8V	PLLVDD 1.8V	CPVDD 1.8V	SPKVDD 5.0V	TOTAL
Quiescent output	2.0mA	0.0mA	0.0mA	1.7mA	0.0mA	0.5mA	0.0mA	7.7mW
0.1mW/channel output HPOUTx_VOL = 5Dh (-28dB)	1.9mA	0.0mA	0.0mA	1.7mA	0.0mA	2.7mA	0.0mA	11.4mW
2mW/channel output HPOUTx_VOL = 69h (-15dB)	2.0mA	0.0mA	0.0mA	1.7mA	0.0mA	10.1mA	0.0mA	25.0mW
16mW/channel output HPOUTx_VOL = 73h (-6dB)	2.0mA	0.0mA	0.0mA	1.7mA	0.0mA	53.7mA	0.0mA	103.4mW
Quiescent output, fs = 48kHz, MCLK = 24.576MHz, MCLK = 512fs, DSP Sound Enhancement enabled CP_DYN_PWR = 0	14.3mA	0.0mA	0.0mA	1.8mA	0.0mA	1.8mA	0.0mA	32.2mW

Stereo DAC Playback to Headphone (HPOUTL, HPOUTR) - High Performance headphone playback mode, 16Ω load.

Default register conditions unless otherwise stated.

Default DAC to Headphone Power Up sequence completed.

DAC_HP = 1, HP_PGAS_BIAS = 000, HP_BIAS_BOOST = 000. (These must be set after running the DAC power-up sequence.)

CP_DYN_PWR = 1

MCLK = 12.288MHz, fs = 48kHz, MCLK rate = 256fs, 24-bit I2S, Slave mode,

Input signal level = 0dBFS, HP1x_VOL = 000b (-7dB),

See "Reference Voltages and Bias Control" for details of the High Performance headphone playback mode.

	DCVDD 1.8V	DBVDD 1.8V	MICVDD 2.5V	AVDD 1.8V	PLLVDD 1.8V	CPVDD 1.8V	SPKVDD 5.0V	TOTAL
Quiescent output	2.0mA	0.0mA	0.0mA	2.5mA	0.0mA	0.5mA	0.0mA	8.9mW
0.1mW/channel output HPOUTx_VOL = 65h (-20dB)	2.1mA	0.0mA	0.0mA	2.5mA	0.0mA	2.9mA	0.0mA	13.3mW
2mW/channel output HPOUTx_VOL = 72h (-7dB)	2.1mA	0.0mA	0.0mA	2.5mA	0.0mA	22.5mA	0.0mA	48.7mW
16mW/channel output HPOUTx_VOL = 79h (-0dB) HP1x_VOL = 2h (-5dB)	2.1mA	0.0mA	0.0mA	2.5mA	0.0mA	59.6mA	0.0mA	115.6mW
Quiescent output, fs = 48kHz, MCLK = 24.576MHz, MCLK = 512fs, DSP Sound Enhancement enabled CP_DYN_PWR = 0	14.4mA	0.0mA	0.0mA	2.5mA	0.0mA	1.8mA	0.0mA	33.8mW

Stereo DAC Playback to Speaker (SPKOUTLP, SPKOUTLN, SPKOUTRP, SPKOUTRN) - 8.2Ω, 2.2μH load.

Default register conditions unless otherwise stated.

Default DAC to Headphone Power Up sequence completed.

DAC_MUTE = 0, DACL_ENA = 1, DACR_ENA = 1,

SPKOUTL_ENA = 1, SPKOUTL_PGA_ENA = 1, SPKOUTL_PGA_MUTE = 1,

SPKOUTR_ENA = 1, SPKOUTR_PGA_ENA = 1, SPKOUTR_PGA_MUTE = 1,

CLASSD_VOL = 111 (+12dB),

VMID_SEL = 01, BIAS_ENA = 1,

MCLK = 12.288MHz, fs = 48kHz, MCLK rate = 256fs, 24-bit I2S, Slave mode,

	DCVDD 1.8V	DBVDD 1.8V	MICVDD 2.5V	AVDD 1.8V	PLLVDD 1.8V	CPVDD 1.8V	SPKVDD 5.0V	TOTAL
Quiescent output	2.4mA	0.0mA	0.0mA	2.7mA	0.0mA	0.0mA	7.3mA	45.7mW
200mW/channel output	2.4mA	0.0mA	0.0mA	2.7mA	0.0mA	0.0mA	91.8mA	468.2mW
1W/channel output	2.3mA	0.0mA	0.0mA	2.6mA	0.0mA	0.0mA	532.7mA	2672.3mW
Quiescent output, fs = 48kHz, MCLK = 24.576MHz, MCLK = 512fs, DSP Sound Enhancement enabled	14.3mA	0.0mA	0.0mA	2.9mA	0.0mA	0.0mA	7.1mA	66.6mW

Clocking Configurations								
Default register conditions unless otherwise stated.								
	DCVDD 1.8V	DBVDD 1.8V	MICVDD 2.5V	AVDD 1.8V	PLLVDD 1.8V	CPVDD 1.8V	SPKVDD 5.0V	TOTAL
PLL3 enabled, 24MHz crystal oscillator reference, PLL3 output = 24.576MHz, MCLK = 12.288MHz.	0.680mA	0.160mA	0.0mA	0.056mA	2.278mA	0.0mA	0.001mA	5.718mW
FLL enabled, 24MHz crystal oscillator reference, FLL output = 12.288MHz, MCLK = 12.288MHz.	1.756mA	0.086mA	0.0mA	0.451mA	1.691mA	0.0mA	0.001mA	7.175mW

Notes:

1. SPKVDD = SPKVDD1 = SPKVDD2.
2. $I_{SPKVDD} = I_{SPKVDD1} + I_{SPKVDD2}$.
3. Speaker load inductance will affect the power consumption; reduced inductance will increase power consumption.

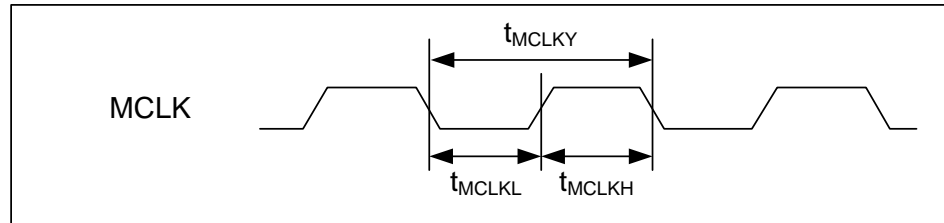
SIGNAL TIMING REQUIREMENTS
MASTER CLOCK

Figure 1 Master Clock Timing
Test Conditions

MICVDD=2.5V, DCVDD = CPVDD=AVDD =1.8V SPKVDD1 = SPKVDD2 = 5V,
 DGND=AGND=CPGND=SPKGND1=SPKGND2=0V, $T_A = +25^\circ\text{C}$

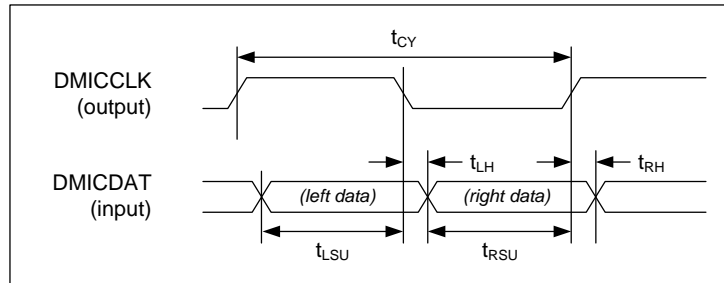
PARAMETER	SYMBOL	CONDITIONS	MIN	TYP	MAX	UNIT
Master Clock Timing						
MCLK cycle time	T_{MCLKY}		20.345			ns
MCLK duty cycle	$T_{MCLKH} : T_{MCLKL}$		60:40		40:60	

AUDIO INTERFACE TIMING
DIGITAL MICROPHONE (DMIC) INTERFACE TIMING

Figure 2 Digital Microphone Interface Timing
Test Conditions

The following timing information is valid across the full range of recommended operating conditions.

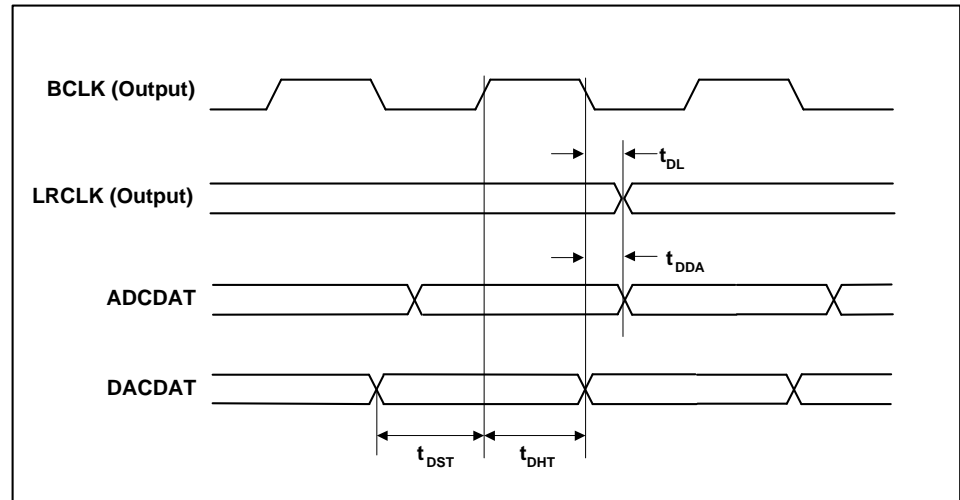
PARAMETER	SYMBOL	MIN	TYP	MAX	UNIT
Digital Microphone Interface Timing					
DMICCLK cycle time	t_{CY}	320			ns
DMICCLK duty cycle		45:55		55:45	
DMICDAT (Left) setup time to falling DMICCLK edge	t_{LSU}	15			ns
DMICDAT (Left) hold time from falling DMICCLK edge	t_{LH}	0			ns
DMICDAT (Right) setup time to rising DMICCLK edge	t_{RSU}	15			ns
DMICDAT (Right) hold time from rising DMICCLK edge	t_{RH}	0			ns

DIGITAL AUDIO INTERFACE - MASTER MODE

Figure 3 Audio Interface Timing - Master Mode
Test Conditions

The following timing information is valid across the full range of recommended operating conditions.

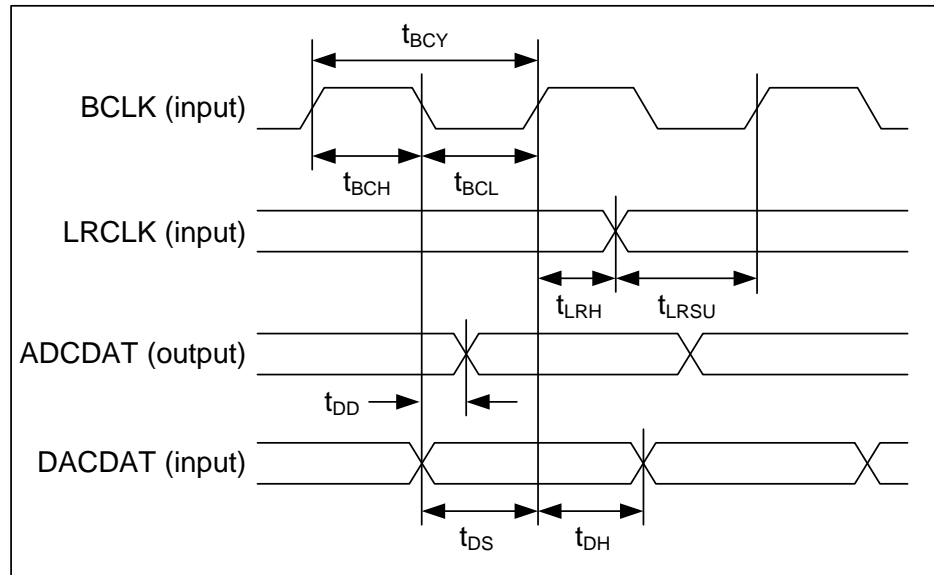
PARAMETER	SYMBOL	MIN	TYP	MAX	UNIT
Audio Interface Timing - Master Mode					
LRCLK propagation delay from BCLK falling edge	t_{DL}			10	ns
ADCDAT propagation delay from BCLK falling edge	t_{DDA}			14	ns
DACDAT setup time to BCLK rising edge	t_{DST}	10			ns
DACDAT hold time from BCLK rising edge	t_{DHT}	10			ns

DIGITAL AUDIO INTERFACE - SLAVE MODE

Figure 4 Audio Interface Timing – Slave Mode
Test Conditions

The following timing information is valid across the full range of recommended operating conditions.

PARAMETER	SYMBOL	MIN	TYP	MAX	UNIT
Audio Interface Timing - Slave Mode					
BCLK cycle time	t_{BCY}	50			ns
BCLK pulse width high	t_{BCH}	20			ns
BCLK pulse width low	t_{BCL}	20			ns
LRCLK set-up time to BCLK rising edge	t_{LRSU}	16			ns
LRCLK hold time from BCLK rising edge	t_{LRH}	10			ns
DACDAT hold time from BCLK rising edge	t_{DH}	10			ns
ADCDAT propagation delay from BCLK falling edge	t_{DD}			14	ns
DACDAT set-up time to BCLK rising edge	t_{DS}	10			ns

Note:

BCLK period should always be greater than or equal to MCLK period.

DIGITAL AUDIO INTERFACE - TDM MODE

In TDM mode, it is important that two devices do not attempt to drive the ADCDAT pin simultaneously. The timing of the WM8962B ADCDAT pin tri-stating at the start and end of the data transmission is described below.

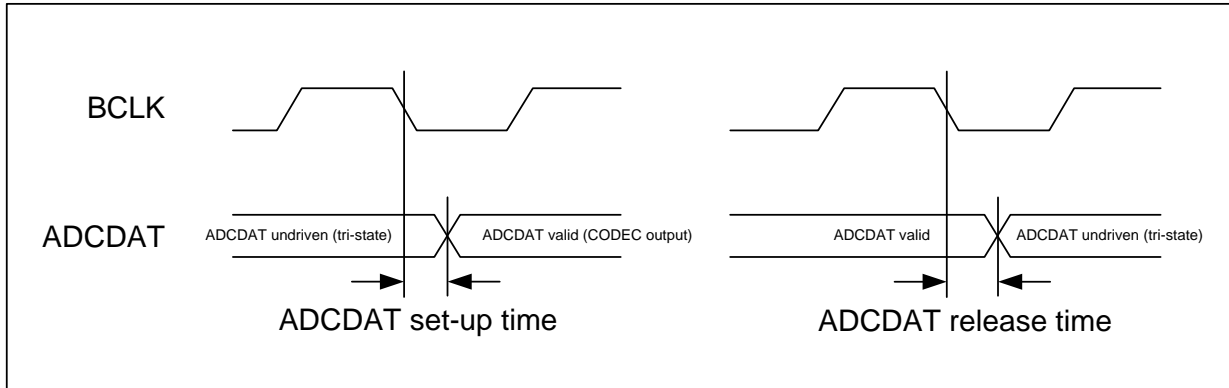
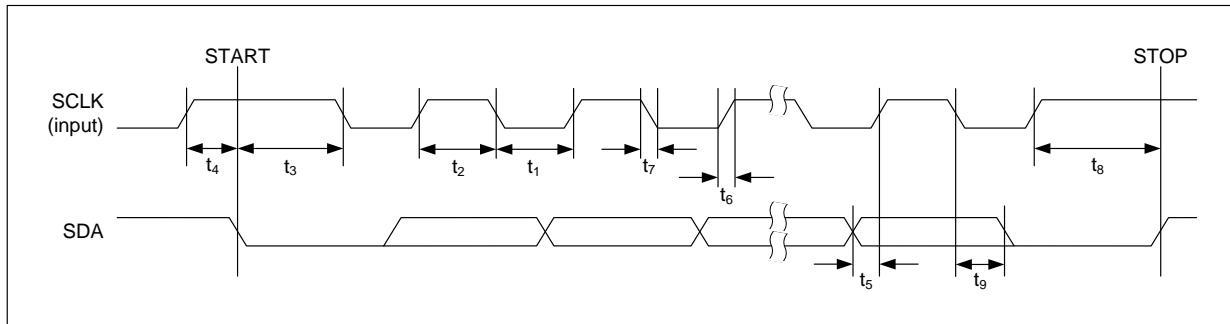

Figure 5 Audio Interface Timing – TDM Mode

Test Conditions

The following timing information is valid across the full range of recommended operating conditions.

PARAMETER	SYMBOL	MIN	TYP	MAX	UNIT
Audio Interface Timing - TDM Mode					
ADCDAT setup time from BCLK falling edge			4		ns
ADCDAT release time from BCLK falling edge			25		ns

CONTROL INTERFACE TIMING
2-WIRE (I2C) CONTROL MODE

Figure 6 Control Interface Timing
Test Conditions

The following timing information is valid across the full range of recommended operating conditions.

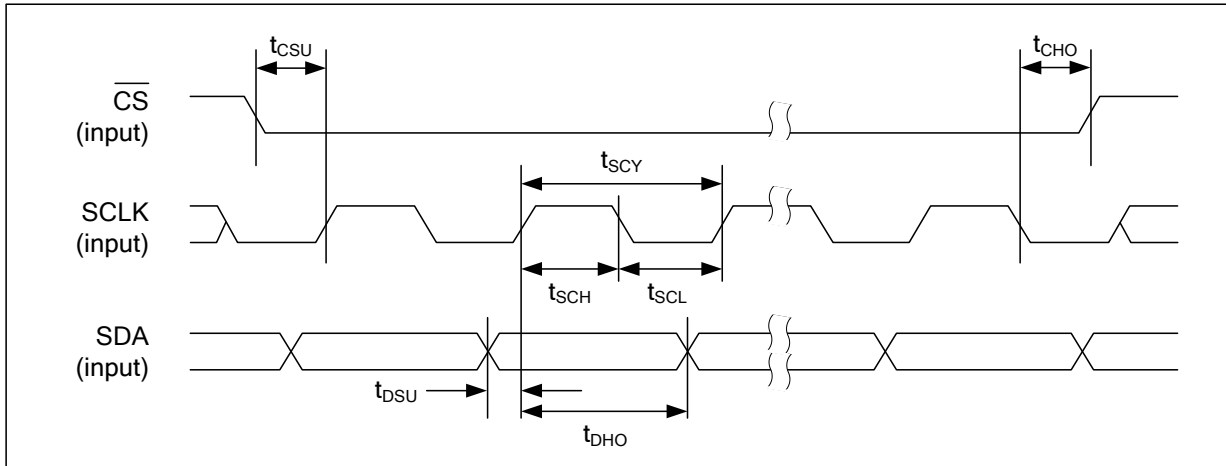
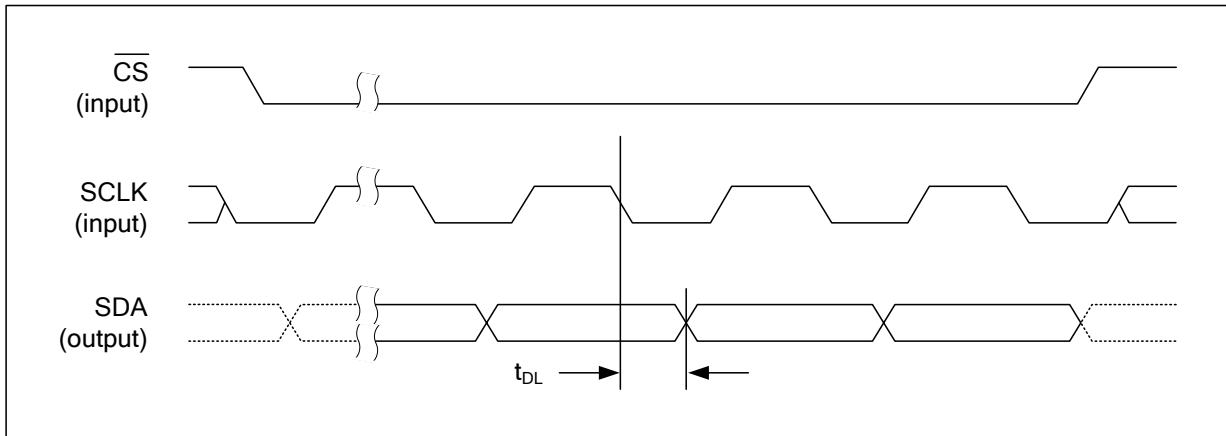
PARAMETER	SYMBOL	MIN	TYP	MAX	UNIT
Program Register Input Information					
SCLK Frequency				526	kHz
SCLK Low Pulse-Width	t_1	1.3			us
SCLK High Pulse-Width	t_2	600			ns
Hold Time (Start Condition)	t_3	600			ns
Setup Time (Start Condition)	t_4	600			ns
Data Setup Time	t_5	100			ns
SDA, SCLK Rise Time	t_6			300	ns
SDA, SCLK Fall Time	t_7			300	ns
Setup Time (Stop Condition)	t_8	600			ns
Data Hold Time	t_9			900	ns
Pulse width of spikes that will be suppressed	t_{ps}	0		5	ns

3-WIRE (SPI) CONTROL MODE

Figure 7 Control Interface Timing - 3-wire (SPI) Control Mode (Write Cycle)

Figure 8 Control Interface Timing - 3-wire (SPI) Control Mode (Read Cycle)
Test Conditions

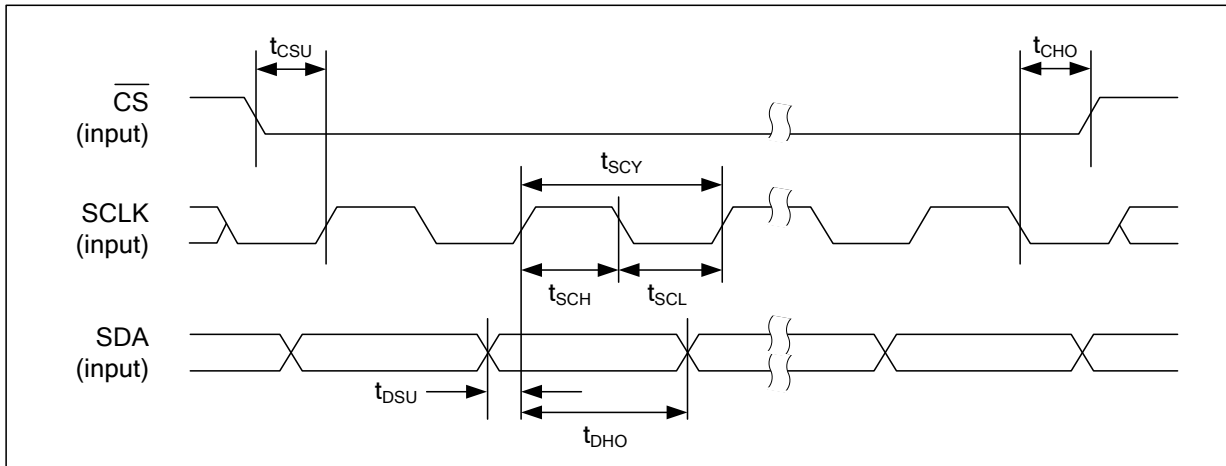
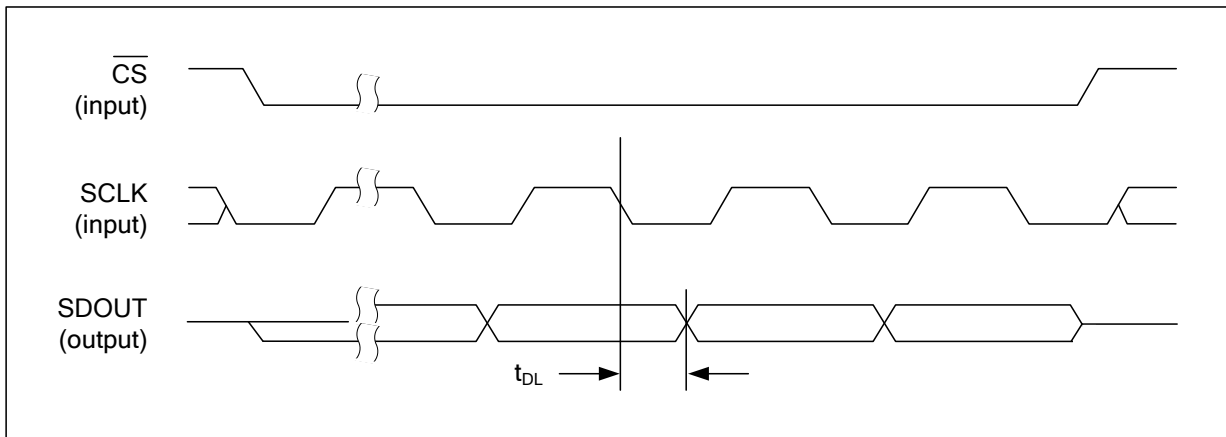
The following timing information is valid across the full range of recommended operating conditions.

PARAMETER	SYMBOL	MIN	TYP	MAX	UNIT
CS falling edge to SCLK rising edge	t_{CSU}	40			ns
SCLK falling edge to CS rising edge	t_{CHO}	10			ns
SCLK pulse cycle time	t_{SCY}	200			ns
SCLK pulse width low	t_{SCL}	80			ns
SCLK pulse width high	t_{SCH}	80			ns
SDA to SCLK set-up time	t_{DSU}	40			ns
SDA to SCLK hold time	t_{DHO}	10			ns
Pulse width of spikes that will be suppressed	t_{ps}	0		5	ns
SCLK falling edge to SDA output transition	t_{DL}			40	ns

4-WIRE (SPI) CONTROL MODE

Figure 9 Control Interface Timing - 4-wire (SPI) Control Mode (Write Cycle)

Figure 10 Control Interface Timing - 4-wire (SPI) Control Mode (Read Cycle)
Test Conditions

The following timing information is valid across the full range of recommended operating conditions.

PARAMETER	SYMBOL	MIN	TYP	MAX	UNIT
CS falling edge to SCLK rising edge	t_{CSU}	40			ns
SCLK falling edge to CS rising edge	t_{CHO}	10			ns
SCLK pulse cycle time	t_{SCY}	200			ns
SCLK pulse width low	t_{SCL}	80			ns
SCLK pulse width high	t_{SCH}	80			ns
SDA to SCLK set-up time	t_{DSU}	40			ns
SDA to SCLK hold time	t_{DHO}	10			ns
Pulse width of spikes that will be suppressed	t_{ps}	0		5	ns
SCLK falling edge to SDOUT transition	t_{DL}			40	ns

POWER ON RESET TIMING

The WM8962B includes an internal Power-On-Reset (POR) circuit, which is used to reset the digital logic into a default state after power up. The POR circuit is powered from AVDD and monitors DCVDD. The internal POR signal is asserted low when AVDD and DCVDD are below minimum thresholds.

A secondary reset circuit is associated with the PLLVDD supply. The PLLs are disabled and the associated registers are undefined when PLLVDD is below its minimum threshold. Full device functionality is not possible until AVDD, DCVDD and PLLVDD are above their respective reset thresholds. The WM8962B can operate with PLLVDD tied to 0V, but the crystal oscillator, PLLs and CLKOUT functions will not be supported.

The specific behaviour of the circuit will vary, depending on the relative timing of the supply voltages. Typical scenarios are illustrated in Figure 11 and Figure 12.

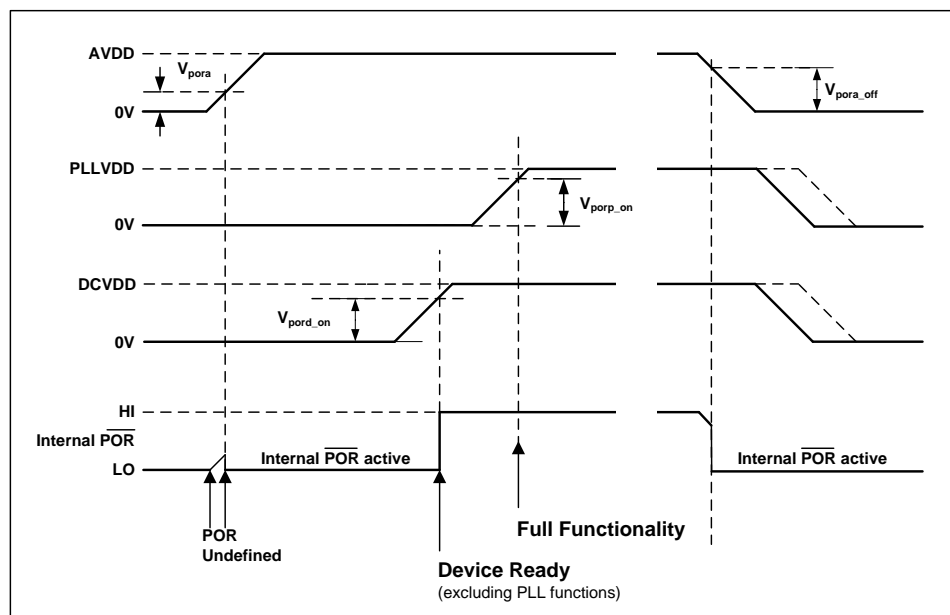
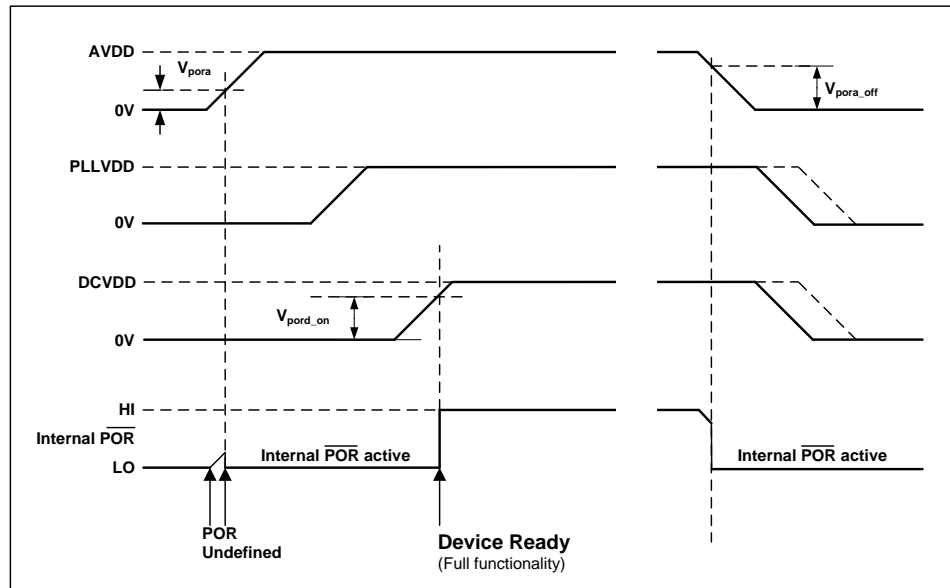

Figure 11 Power On Reset Timing - AVDD Enabled First

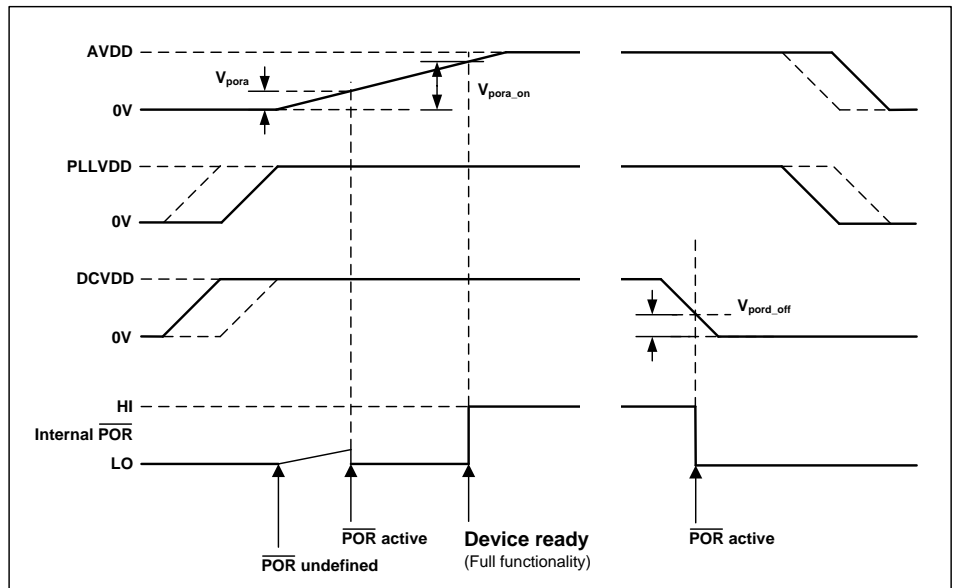
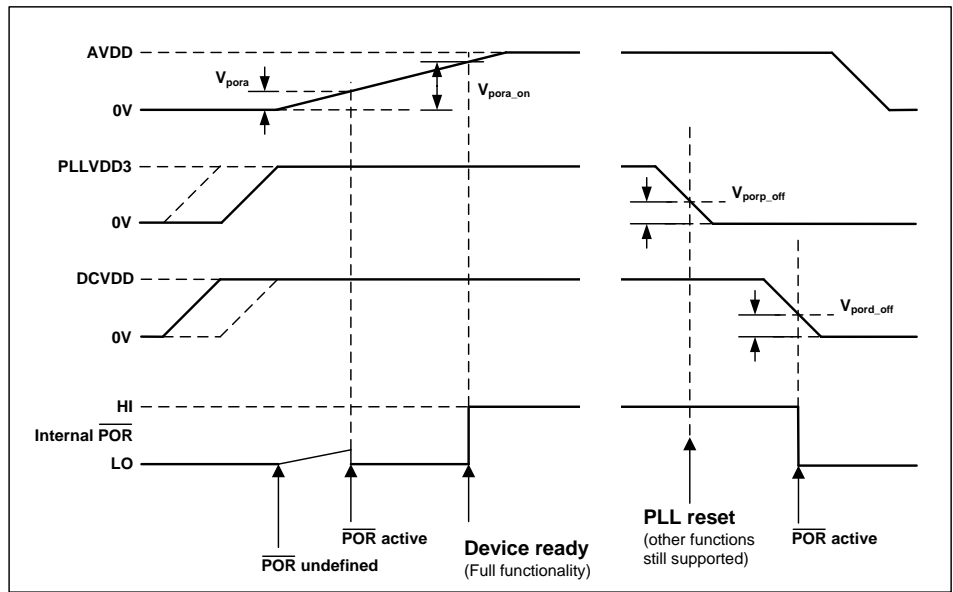

Figure 12 Power On Reset Timing - DCVDD Enabled First

The POR signal is undefined until AVDD has exceeded the minimum threshold, V_{pora} . Once this threshold has been exceeded, POR is asserted low and the chip is held in reset. In this condition, all writes to the control interface are ignored. Once AVDD and DCVDD have reached their respective power on thresholds, POR is released high, all registers are in their default state, and writes to the control interface may take place.

A secondary reset circuit is associated with the PLLVDD supply. The PLLs are disabled and the associated registers are undefined when PLLVDD is below its minimum threshold.

Note that a minimum power-on reset period, T_{POR} , applies even if AVDD and DCVDD have zero rise time. (This specification is guaranteed by design rather than test.)

On power down, POR is asserted low when any of AVDD or DCVDD falls below their respective power-down thresholds.

Typical Power-On Reset parameters for the WM8962B are defined in Table 1.

SYMBOL	DESCRIPTION	TYP	UNIT
V_{pora}	AVDD threshold below which POR is undefined	0.5	V
V_{pora_on}	Power-On threshold (AVDD)	1.1	V
V_{pora_off}	Power-Off threshold (AVDD)	1.1	V
V_{pord_on}	Power-On threshold (DCVDD)	0.9	V
V_{pord_off}	Power-Off threshold (DCVDD)	0.65	V
V_{porp_on}	PLL start-up threshold (PLLVDD)	1.1	V
V_{porp_off}	PLL reset threshold (PLLVDD)	1.1	V
T_{POR}	Minimum Power-On Reset period	9.5	μ s

Table 1 Typical Power-On Reset Parameters

Notes:

1. If AVDD and DCVDD suffer a brown-out (i.e. drop below the minimum recommended operating level but do not go below V_{pora_off} or V_{pord_off}), then the chip does not reset and resumes normal operation when the voltage is back to the recommended level again.
2. The chip enters reset at power down when AVDD or DCVDD falls below V_{pora_off} or V_{pord_off} . This may be important if the supply is turned on and off frequently by a power management system.
3. The minimum T_{POR} period is maintained even if DCVDD and AVDD have zero rise time. This specification is guaranteed by design rather than test.
4. The WM8962B can operate with PLLVDD tied to 0V, but the crystal oscillator, PLLs and CLKOUT functions will not be supported.

DEVICE DESCRIPTION

INTRODUCTION

The WM8962B is a low power audio CODEC offering a combination of high quality audio, advanced features, low power and small size. These characteristics make it ideal for portable digital audio applications with stereo speaker and headphone outputs such as games consoles, portable media players and multimedia phones.

A flexible input configuration supports a single-ended stereo microphone interface and a digital microphone interface. A boost amplifier is available for additional gain on the microphone inputs. A programmable gain amplifier (PGA) with an automatic level control (ALC) function can be used to maintain a constant microphone recording volume.

Stereo class D speaker drivers can provide up to 2W per channel into 4Ω BTL loads. It is also possible to configure the speaker drivers as a mono output, giving enhanced performance.

Highly flexible output speaker boost settings provide fully internal level-shifting of analogue output signals, allowing speaker output power to be maximised while minimising other analogue supply currents, and requiring no additional components.

A dual mode (Level Shifting or Inverting Mode) charge pump generates split supplies for the headphone output amplifiers allowing these to be ground referenced.

A DC servo to remove offsets from the headphone outputs, low leakage and a user controlled power-up/power-down Control Sequencer provides powerful pop and click suppression mechanisms which enable direct battery connection. These anti-pop/click mechanisms, and no requirement for any external DC blocking capacitors to the headphone, result in a reduced external component count and reduced power consumption in portable battery-powered applications.

The hi-fi quality stereo ADC and DAC uses a 24-bit, low-order over-sampling architecture to deliver optimum performance. ADC and DAC operate at the same sample rate.

An audio enhancement DSP provides powerful benefits in audio processing. Three algorithms are pre-programmed in the DSP. ReTune™ flattens the frequency response of the full record and/or playback path, including microphone, speaker and housing. Virtual Surround Sound widens the stereo speaker audio image. High Definition Bass enhances low frequencies, improving the performance of small speakers. Further audio enhancements are provided in a fix function DSP – 3D enhancement, a 5-band parametric equaliser, and a Dynamic Range Controller.

The WM8962B has a highly flexible digital audio interface, supporting a number of protocols, including I2S, DSP, MSB-first left/right justified, and can operate in master or slave modes. PCM operation is supported in the DSP mode. A-law and μ -law companding are also supported. Time division multiplexing (TDM) is available to allow multiple devices to stream data simultaneously on the same bus, saving space and power.

The WM8962B provides two integrated PLLs and one FLL to generate internal and external clock signals. The SYSCLK (internal system clock) provides clocking for all internal functions. SYSCLK can be derived directly from the MCLK pin, or else using one of the PLLs or the FLL. All MCLK frequencies typically used in portable systems are supported for sample rates between 8 kHz and 96 kHz. The ADC and DAC must be configured to operate at the same sample rate. A flexible switching clock for the class D speaker drivers (synchronous with the audio DSP clocks for best performance) is also derived from SYSCLK.

To allow full software control over all its features, the WM8962B supports 2-wire (I2C) and 3- or 4-wire (SPI) serial control interface modes, with full read-back capability on all registers. The WM8962B is fully compatible with, and an ideal partner to, a wide range of industry standard microprocessors, controllers and DSPs. Unused functions can be disabled via software to save power, while low leakage currents extend standby and off time in portable battery-powered applications.

INPUT SIGNAL PATH

The WM8962B has many analogue input channels, configurable in combinations of up to eight mono inputs or four stereo inputs.

Any of the analogue inputs may be connected to the input PGA on the associated left or right channel. (Note that only one analogue input can be connected to the PGA at any time; the PGA does not perform any signal mixing.)

The left and right analogue inputs IN2 and IN3 can be connected to the input boost mixer on the associated left or right channel, bypassing the input PGA.

Note that the input signal path audio performance is affected by the choice of signal path. Best performance is achieved using analogue inputs IN2 or IN3 connected directly to the input boost mixer. The performance of the input signal paths are ranked as described in the list below (best performance first).

- IN2 or IN3 connected directly to the input boost mixer
- IN1 or IN4 connected via the input PGA
- IN2 or IN3 connected via the input PGA

The left and right analogue inputs IN4 can be connected directly to the output signal mixers, which drive the headphone or speaker outputs.

The input signal paths and the control registers are shown in Figure 13.

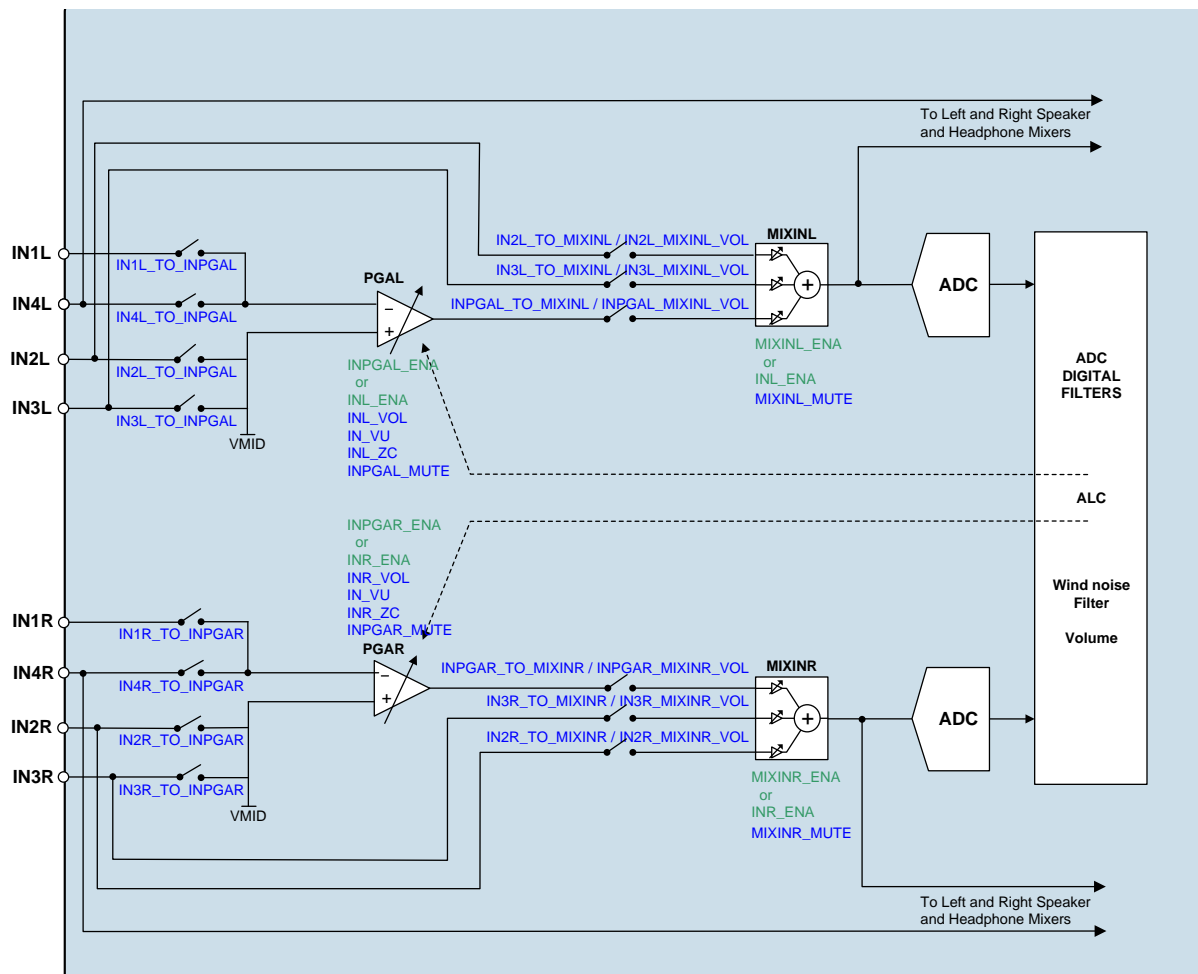

Figure 13 Analogue Input Signal Path

MICROPHONE INPUT CONNECTION

The WM8962B supports analogue and digital microphone input. Refer to the “Digital Microphone Interface” section for details of the digital microphone input.

The input PGAs can support a single-ended analogue microphone input. A microphone bias generator is also provided, suitable for powering electret condenser microphones.

Single-ended analogue microphone input using IN1L, IN1R, IN4L or IN4R is configured as shown in Figure 14.

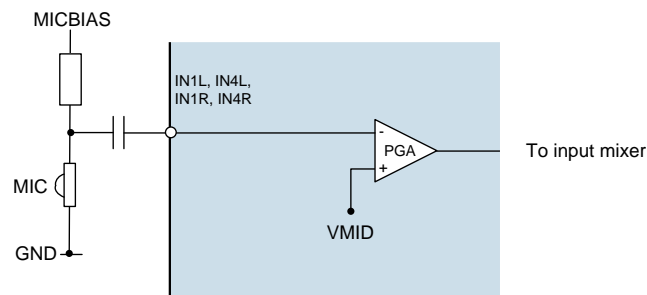

Figure 14 Microphone Input IN1 or IN4

When using IN2L, IN2R, IN3L or IN3R as an input to the PGA, the respective IN1 pin (IN1L or IN1R) must be connected to ground via an external capacitor, as shown in Figure 15.

Note that when IN2L, IN2R, IN3L or IN3R is selected as input to the PGA (using the register bits described in Table 6), the respective IN1 pin (IN1L or IN1R) is automatically connected to the PGA in order to support the capacitor requirement described above.

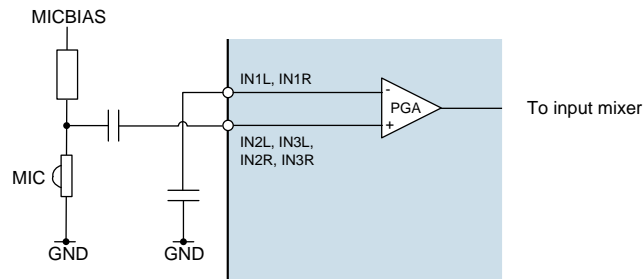

Figure 15 Microphone Input IN2 or IN3

LINE INPUT CONNECTION

Single-ended line inputs may be connected to the left or right channel analogue inputs IN1, IN2, IN3 or IN4, and routed to the input mixers or output signal paths as illustrated in Figure 14.

If IN2L, IN2R, IN3L or IN3R is used as an input to the PGA, then the respective IN1 pin (IN1L or IN1R) must be connected to ground via an external capacitor, as shown in Figure 15.

Note that when IN2L, IN2R, IN3L or IN3R is selected as input to the PGA (using the register bits described in Table 6), the respective IN1 pin (IN1L or IN1R) is automatically connected to the PGA in order to support the capacitor requirement described above.

MICROPHONE BIAS CONTROL

There is one MICBIAS generator which provides low noise reference voltages suitable for biasing electret condenser (ECM) type microphones via an external resistor.

Note that an external decoupling capacitor is required on the MICBIAS output. A suitable capacitor must be connected whenever the MICBIAS output is enabled. Additional filtering of the MICBIAS output, to reduce noise and interference, may be implemented as described in the “Applications Information” section, if required.

The MICBIAS output is enabled using the MICBIAS_ENA register bit. The MICBIAS voltage is selected using the MICBIAS_LVL and MICBIAS_EVR register fields, as detailed in Table 2.

REGISTER ADDRESS	BIT	LABEL	DEFAULT	DESCRIPTION
R25 (19h) Pwr Mgmt (1)	1	MICBIAS_ENA	0	Microphone Bias Enable 0 = OFF (high impedance output) 1 = ON
R29 (1Dh) Pwr Mgmt (3)	1:0	MICBIAS_EVR [1:0]	00	Microphone Bias Voltage Control 00 = Controlled by MICBIAS_LVL 01 = 1.63 x AVDD (approx.) 10 = 1.34 x AVDD (approx.) 11 = 1.63 x AVDD (approx.)
R48 (30h) MICBIAS	0	MICBIAS_LVL	1	Microphone Bias Voltage Control 0 = 0.828 x AVDD (approx.) 1 = 1.156 x AVDD (approx.) Only valid when MICBIAS_EVR=00. In other cases, the Microphone Bias voltage is controlled by MICBIAS_EVR alone.

Table 2 Microphone Bias Control

Note that the maximum source current capability for MICBIAS is 2.0mA. The external biasing resistance must be large enough to limit the MICBIAS current to 2.0mA across the full microphone impedance range.

Note that the MICVDD supply voltage must be at least 300mV higher than the desired MICBIAS output voltage.

MICBIAS CURRENT DETECT

A MICBIAS Current Detect function is provided for external accessory detection. This is provided in order to detect the insertion/removal of a microphone or the pressing/releasing of the microphone ‘hook’ switch; these events will cause a significant change in MICBIAS current flow, which can be detected and used to generate a signal to the host processor.

The MICBIAS current detect function is enabled by setting the MICDET_ENA register bit. When this function is enabled, two current thresholds can be defined, using the MICDET_THR and MICSHORT_THR registers. When a change in MICBIAS current which crosses either threshold is detected, then an interrupt event can be generated. In a typical application, accessory insertion would be detected when the MICBIAS current exceeds MICDET_THR, and microphone hookswitch operation would be detected when the MICBIAS current exceeds MICSHORT_THR.

The current detect threshold functions are both inputs to the Interrupt control circuit and can be used to trigger an Interrupt event when either threshold is crossed. Both events can also be indicated as an output on a GPIO pin - see “General Purpose Input/Output (GPIO)”. The status flags MICDET_STS or MICSHORT_STS are also asserted whenever the relevant current threshold is exceeded.

The current detect thresholds are enabled and controlled using the registers described in Table 3 Performance parameters for this circuit block can be found in the “Electrical Characteristics” section.

Filtering is also provided in both current detect circuits to improve reliability in conditions where AC current spikes are present due to ambient noise conditions. This feature is described in the following section. Further guidance on the usage of the MICBIAS current monitoring features is also described in the following pages.

REGISTER ADDRESS	BIT	LABEL	DEFAULT	DESCRIPTION
R48 (30h) Additional Control (4)	14:12	MICDET_THR [2:0]	000	MICBIAS Current Detect Threshold (AVDD = 1.8V) 000 = 64uA 001 = 166uA 010 = 375uA 011 = 475uA 100 = 575uA 101 = 680uA 110 = 885uA 111 = 990uA Note that the value scales with AVDD. The value quoted is correct for AVDD=1.8V.
	11:10	MICSHORT_THR [1:0]	00	MICBIAS Short Circuit Threshold (AVDD = 1.8V) 00 = 515uA 01 = 680uA 10 = 1050uA 11 = 1215uA Note that the value scales with AVDD. The value quoted is correct for AVDD=1.8V.
	9	MICDET_ENA	0	MICBIAS Current and Short Circuit Detect Enable 0 = Disabled 1 = Enabled
	7	MICDET_STS	0	MICBIAS Current Detection status 0 = Current Detect threshold not exceeded 1 = Current Detect threshold exceeded
	6	MICSHORT_STS	0	MICBIAS Short Circuit status 0 = Short Circuit threshold not exceeded 1 = Short Circuit threshold exceeded

Table 3 MICBIAS Current Detect

MICBIAS CURRENT DETECT FILTERING

The function of the filtering is to ensure that AC current spikes caused by ambient noise conditions near the microphone do not lead to incorrect signalling of the microphone insertion/removal status or the microphone hookswitch status.

Digital filtering of the hookswitch status ensures that the MICBIAS Short Circuit detection event is only signalled if the MICSHORT_THR threshold condition has been met for 10 consecutive measurements.

In a typical application, microphone insertion would be detected when the MICBIAS current exceeds the Current Detect threshold set by MICDET_THR.

When the MICD_IRQ_POL interrupt polarity bit is set to 0, then microphone insertion detection will cause the MICD_EINT interrupt status register to be set. (See "Interrupts" for details of these register bits.)

For detection of microphone removal, the MICD_IRQ_POL bit should be set to 1. When the MICD_IRQ_POL interrupt polarity bit is set to 1, then microphone removal detection will cause the MICD_EINT interrupt status register to be set.

The detection of these events is bandwidth limited for best noise rejection, and is subject to detection delay time t_{DET} , as specified in the “Electrical Characteristics” section. Provided that the MICDET_THR field has been set appropriately, each insertion or removal event will be detected within the delay time t_{DET} .

It is likely that the microphone socket contacts will have mechanical “bounce” when a microphone is inserted or removed, and hence the resultant control signal will not be a clean logic level transition. Since t_{DET} has a range of values, it is possible that the interrupt will be generated before the mechanical “bounce” has ceased. Hence after a mic insertion or removal has been detected, a time delay should be applied before re-configuring the MICD_IRQ_POL bit. The maximum possible mechanical bounce times for mic insertion and removal must be understood by the software programmer.

Utilising a GPIO pin to monitor the steady state of the microphone detection function does not change the timing of the detection mechanism, so there will also be a delay t_{DET} before the signal changes state. It may be desirable to implement de-bounce in the host processor when monitoring the state of the GPIO signal.

Microphone hook switch operation is detected when the MICBIAS current exceeds the Short Circuit Detect threshold set by MICSHORT_THR. Using the digital filtering, the hook switch detection event is only signalled if the MICSHORT_THR threshold condition has been met for 10 consecutive measurements.

When the MICSCD_IRQ_POL interrupt polarity bit is set to 0, then hook switch operation will cause the MICSCD_EINT interrupt status register to be set. (See “Interrupts” for details of these register bits.)

For detection of microphone removal, the MICSCD_IRQ_POL bit should be set to 1. When the MICSCD_IRQ_POL interrupt polarity bit is set to 1, then hook switch release will cause the MICSCD_EINT interrupt status register to be set.

The hook switch detection measurement frequency and the detection delay time t_{SHORT} are detailed in the “Electrical Characteristics” section.

The WM8962B Interrupt function is described in the “Interrupts” section. Example control sequences for configuring the Interrupts functions for MICBIAS current detection events are described in the “Applications Information” section.

A clock is required for the digital filtering function. This requires:

- MCLK is present or the FLL is selected as the SYSCLK source in free-running mode
- SYSCLK_ENA = 1

Any MICBIAS Current Detect event (accessory insertion/removal or hookswitch press/release) which happens while one or more of the clocking criteria is not satisfied (for example during a low power mode where the CPU has disabled MCLK) will still be detected, but only after the clocking conditions are met. An example is illustrated in Figure 16, where the mic is inserted while MCLK is stopped.

Note that the interrupts and digital filtering can be supported in the absence of an external clock by using the FLL in free-running mode and selecting the FLL as the clock source, as described in “Clocking and Sample Rates”.

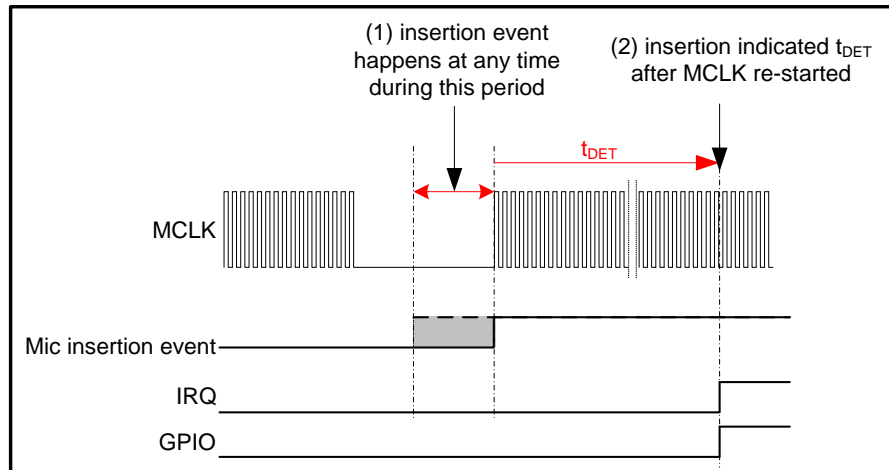

Figure 16 MICBIAS Detection Events without MCLK

MICROPHONE HOOK SWITCH DETECTION

The possibility of spurious hook switch interrupts due to ambient noise conditions can be removed by detailed understanding of microphone behaviour under extremely high sound pressure levels or during mechanical shock, and by correct selection of the MICBIAS resistor value; these factors will affect the level of the MICBIAS AC current spikes.

In applications where the Current Detect threshold is close to the level of the current spikes, the probability of false detections is reduced by the digital filtering described above.

Note that the filtering algorithm provides only limited rejection of very high current spikes at frequencies less than or equal to the hook switch detect measurement frequency, or at frequencies equal to harmonics of the hook switch detect measurement frequency.

The MICBIAS Hook Switch detection filtering is illustrated in Figure 17. Example control sequences for configuring the Interrupts functions for MICBIAS current detection events are described in the “Applications Information” section.

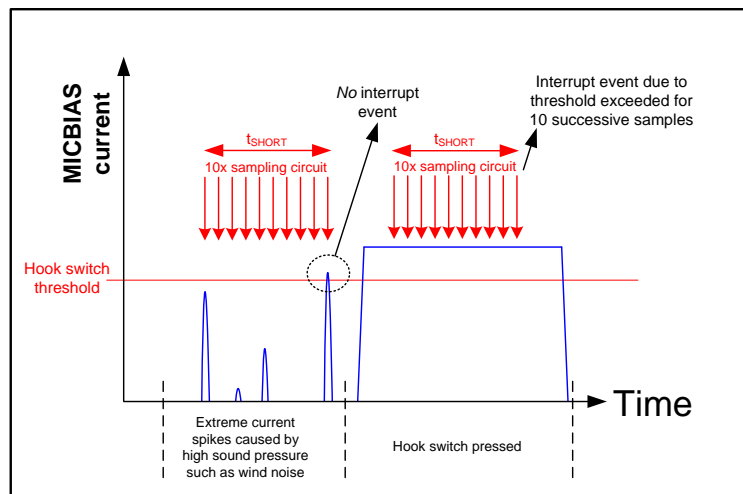

Figure 17 MICBIAS Hook Switch Detection Filtering

MULTIPLE PUSH BUTTON DETECTION

The MICDET_THR and MICSHORT_THR current detection thresholds can be used to detect accessory insertion and hook switch status as described above. The WM8962B can also be configured to support multiple button detection, as illustrated in Figure 18.

Multiple push button detection is supported using carefully chosen resistors to distinguish one push button from another, and by using the WM8962B Analogue to Digital Converter (ADC) to measure the potential divider formed between the MICBIAS resistor and the push button resistors.

The push buttons are connected in parallel, each with a uniquely-valued series resistor. Assertion of any of the push buttons will result in a different voltage measurement, depending on which button has been pressed.

The resistor values must be carefully selected to ensure that each push button can be reliably and uniquely recognised. It must also be ensured that the DC connection (to pin IN4L as illustrated in Figure 18) does not exceed the maximum input voltage for that pin. Note that the MICBIAS voltage may need to be reduced as a result.

In order to meet the maximum input voltage limit described above, it is required that MICBIAS_EVR=00 under the circuit configuration shown.

Note that the IN1L and IN4L input paths should not be enabled simultaneously as inputs to the PGA. As a result, it should be noted that the microphone/line audio input path to the PGA cannot be supported at the same time as DC measurement via the same PGA.

In a typical application, the MICBIAS short circuit detect feature should be used to detect a push button operation in the first instance. When this event has been detected, then IN1L should be disabled, and IN4L should then be enabled to allow the ADC measurement to determine which button has been pressed.

The push button detection mechanism described here can be implemented using the IN4L pin or the IN4R pin. It is not recommended to use any other input pin for push button detection.

When using the DC voltage measurement function, the IN4 pins must be configured using the register sequence described in Table 4, in order to disconnect these pins from the internal voltage reference.

REGISTER ADDRESS	VALUE
FDh	0001h
CCh	0040h
FDh	0000h

Table 4 Input Pins IN4L and IN4R Configuration for Push Button Detection

When using the ADC to perform DC voltage measurement for push button detection, the ADC High Pass Filter must be disabled. See “ADC Signal Path Enhancements” for details of the ADC_HPF_DIS register bit to control this filter. It is recommended to set the PGA gain to 0dB for DC measurement.

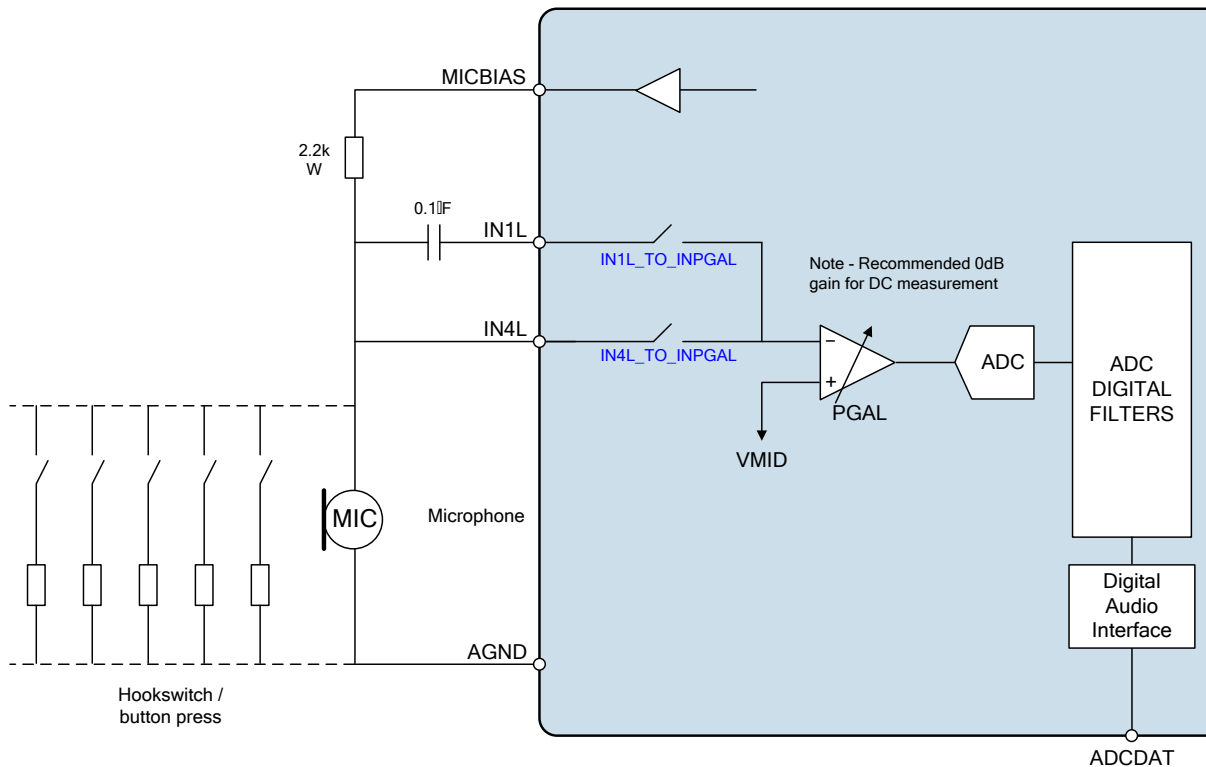

Figure 18 Multiple Hook Switch Detection

INPUT PGA ENABLE

The WM8962B has two input PGAs (Programmable Gain Amplifiers), which provide adjustable gain on the applicable input signal paths.

The input PGAs are enabled using register bits INL_ENA, INR_ENA, INPGAR_ENA and INPGAL_ENA, as described in Table 5.

REGISTER ADDRESS	BIT	LABEL	DEFAULT	DESCRIPTION
R25 (19h) Pwr Mgmt (1)	5	INL_ENA	0	Left Input PGA and Mixer Enable. 0 = Disabled 1 = Enabled
	4	INR_ENA	0	Right Input PGA and Mixer Enable. 0 = Disabled 1 = Enabled
R37 (25h) Left Input PGA Control	4	INPGAL_ENA	0	Left Input PGA Enable 0 = Disabled 1 = Enabled Note that the Left Input PGA is also enabled when INL_ENA is set
R38 (26h) Right Input PGA Control	4	INPGAR_ENA	0	Right Input PGA Enable 0 = Disabled 1 = Enabled Note that the Right Input PGA is also enabled when INR_ENA is set

Table 5 Input PGA Enable

To enable the input PGAs, the reference voltage VMID and the bias current must also be enabled. See "Reference Voltages and Bias Control" for details of the associated controls VMID_SEL and BIAS_ENA.

INPUT PGA CONFIGURATION

Each of the PGAs operates in a single-ended mode. Configuration of the PGA inputs to the WM8962B input pins is controlled using the register bits shown in Table 6.

The maximum available attenuation on any of these input paths is achieved by using register bits shown in Table 6 to disconnect the input pins from the applicable PGA.

REGISTER ADDRESS	BIT	LABEL	DEFAULT	DESCRIPTION
R37 (25h) Left input PGA control	3	IN1L_TO_INPGAL	1	Selects the IN1L pin as an input to the Left PGA 0 = Disabled 1 = Enabled
	2	IN2L_TO_INPGAL	0	Selects the IN2L pin as an input to the Left PGA 0 = Disabled 1 = Enabled
	1	IN3L_TO_INPGAL	0	Selects the IN3L pin as an input to the Left PGA 0 = Disabled 1 = Enabled
	0	IN4L_TO_INPGAL	0	Selects the IN4L pin as an input to the Left PGA 0 = Disabled 1 = Enabled
R38 (26h) Right input PGA control	3	IN1R_TO_INPGA R	1	Selects the IN1R pin as an input to the Right PGA 0 = Disabled 1 = Enabled
	2	IN2R_TO_INPGA R	0	Selects the IN2R pin as an input to the Right PGA 0 = Disabled 1 = Enabled
	1	IN3R_TO_INPGA R	0	Selects the IN3R pin as an input to the Right PGA 0 = Disabled 1 = Enabled
	0	IN4R_TO_INPGA R	0	Selects the IN4R pin as an input to the Right PGA 0 = Disabled 1 = Enabled

Table 6 Input PGA Configuration

INPUT PGA VOLUME CONTROL

Each of the two Input PGAs has an independently controlled gain range of -23.25dB to +24dB in 0.75dB steps. Each Input PGA can be independently muted using the PGA mute bits as described in Table 7, with maximum mute attenuation achieved by simultaneously disabling the corresponding inputs described in Table 6.

To prevent "zipper noise", a zero-cross function is provided on the input paths. When this feature is enabled, volume updates will not take place until a zero-crossing is detected. In the case of a long period without zero-crossings, a timeout function is provided. When the zero-cross function is enabled, the volume will update after the timeout period if no earlier zero-cross has occurred. The timeout clock is enabled using TOCLK_ENA, the timeout period is set by TOCLK_DIV. See "Clocking and Sample Rates" for more information on these fields.

The IN_VU bits control the loading of the input PGA volume data and the PGA mute functions. When IN_VU is set to 0, the PGA volume data will be loaded into the respective control register, but will not actually change the gain setting. The INL and INR volume settings are both updated when a 1 is written to either IN_VU bit. Similarly, the INPGAL_MUTE and INPGAR_MUTE settings are only effective when a 1 is written to either IN_VU bit. This makes it possible to update the gain/mute of the left and right signal paths simultaneously.

Note that the Input PGA control has a dependency on the correct sequencing of the ALC and ADC Enable control registers; if the correct sequences are not followed, then the Input PGA gain settings may become fixed. See "Automatic Level Control (ALC)" for further details.

The Input PGA Volume Control register fields are described in Table 7 and Table 8.

REGISTER ADDRESS	BIT	LABEL	DEFAULT	DESCRIPTION
R0 (0h) Left input volume	8	IN_VU	N/A	Input PGA Volume and Mute Update Writing a 1 to this bit will cause the INL and INR volume and mute settings to be updated simultaneously
	7	INPGAL_MUTE	1	Left input PGA Mute 0 = Unmuted 1 = Muted
	6	INL_ZC	0	INL PGA Zero Cross Detector 0 = Change gain immediately 1 = Change gain on zero cross only
	5:0	INL_VOL [5:0]	011111 (0dB)	Left input PGA Volume -23.25dB to +24.00dB in 0.75dB steps. See Table 8 for volume range.
R1 (1h) Right input volume	8	IN_VU	N/A	Input PGA Volume and Mute Update Writing a 1 to this bit will cause the INL and INR volume and mute settings to be updated simultaneously
	7	INPGAR_MUTE	1	Right input PGA Mute 0 = Unmuted 1 = Muted
	6	INR_ZC	0	INR PGA Zero Cross Detector 0 = Change gain immediately 1 = Change gain on zero cross only
	5:0	INR_VOL [5:0]	01_1111 (0dB)	Right input PGA Volume -23.25dB to +24.00dB in 0.75dB steps. See Table 8 for volume range.

Table 7 Input PGA Volume Control

INL_VOL[5:0], INR_VOL[5:0]	VOLUME (dB)	INL_VOL[5:0], INR_VOL[5:0]	VOLUME (dB)
00_0000	-23.25	10_0000	0.75
00_0001	-22.50	10_0001	1.50
00_0010	-21.75	10_0010	2.25
00_0011	-21.00	10_0011	3.00
00_0100	-20.25	10_0100	3.75
00_0101	-19.50	10_0101	4.50
00_0110	-18.75	10_0110	5.25
00_0111	-18.00	10_0111	6.00
00_1000	-17.25	10_1000	6.75
00_1001	-16.50	10_1001	7.50
00_1010	-15.75	10_1010	8.25
00_1011	-15.00	10_1011	9.00
00_1100	-14.25	10_1100	9.75
00_1101	-13.50	10_1101	10.50
00_1110	-12.75	10_1110	11.25
00_1111	-12.00	10_1111	12.00
01_0000	-11.25	11_0000	12.75
01_0001	-10.50	11_0001	13.50
01_0010	-9.75	11_0010	14.25
01_0011	-9.00	11_0011	15.00
01_0100	-8.25	11_0100	15.75
01_0101	-7.50	11_0101	16.50
01_0110	-6.75	11_0110	17.25
01_0111	-6.00	11_0111	18.00
01_1000	-5.25	11_1000	18.75
01_1001	-4.50	11_1001	19.50
01_1010	-3.75	11_1010	20.25
01_1011	-3.00	11_1011	21.00
01_1100	-2.25	11_1100	21.75
01_1101	-1.50	11_1101	22.50
01_1110	-0.75	11_1110	23.25
01_1111	0.00	11_1111	24.00

Table 8 Input PGA Volume Range

INPUT MIXER ENABLE

The WM8962B has two analogue input mixers, which provide mixing and signal boost functions for the analogue input paths.

The input mixers MIXINL and MIXINR are enabled by the MIXINL_ENA and MIXINR_ENA register bits, as described in Table 9. Note that the input mixers can also be controlled by INL_ENA and INR_ENA, as described in Table 5.

REGISTER ADDRESS	BIT	LABEL	DEFAULT	DESCRIPTION
R31 (1Fh) Input mixer control (1)	1	MIXINL_ENA	0	Left Input Mixer Enable 0 = Disabled 1 = Enabled Note that the Left Input Mixer is also enabled when INL_ENA is set
	0	MIXINR_ENA	0	Right Input Mixer Enable 0 = Disabled 1 = Enabled Note that the Right Input Mixer is also enabled when INR_ENA is set

Table 9 Input Mixer Enable

INPUT MIXER CONFIGURATION AND VOLUME CONTROL

The analogue input mixers MIXINL and MIXINR can be configured to take input from the input PGAs and also directly from the IN2 and IN3 inputs pins.

The Input Boost Mixer configuration and volume controls are described in Table 10 for the Left input boost-mixer (MIXINL) and Table 11 for the Right input boost-mixer (MIXINR).

Note that the available mixer gain settings for the IN2 and IN3 paths are different to the input PGA signal paths. The IN2 and IN3 signal paths can be controlled from -12dB to +6dB. The input PGA signal paths can be controlled from 0dB to +29dB.

To prevent pop noise, it is recommended that gain and mute controls for the input boost mixers are not modified while the signal paths are active. If volume control is required on these signal paths, it is recommended that this is implemented using the input PGA volume controls or the ADC volume controls. The ADC volume controls are described in the “Analogue To Digital Converter (ADC)” section.

REGISTER ADDRESS	BIT	LABEL	DEFAULT	DESCRIPTION
R31 (1Fh) Input mixer control (1)	3	MIXINL_MUTE	0	Left input boost-mixer mute 0 = Un-mute 1 = Mute
R32 (20h) Left input mixer volume	8:6	IN2L_MIXINL_VOL [2:0]	101	Left input IN2L to Left input Boost-Mixer Gain 000 = -12dB 001 = -12dB 010 = -9dB 011 = -6dB 100 = -3dB 101 = 0dB 110 = +3dB 111 = +6dB

REGISTER ADDRESS	BIT	LABEL	DEFAULT	DESCRIPTION
	5:3	INPGAL_MIXINL_VOL [2:0]	000	Left input PGA to Left input Boost-Mixer Gain 000 = 0dB 001 = +6dB 010 = +13dB 011 = +18dB 100 = +20dB 101 = +24dB 110 = +27dB 111 = +29dB
	2:0	IN3L_MIXINL_VOL [2:0]	101	Left input IN3L to Left input Boost-Mixer Gain 000 = -12dB 001 = -12dB 010 = -9dB 011 = -6dB 100 = -3dB 101 = 0dB 110 = +3dB 111 = +6dB
R34 (22h) Input mixer control (2)	5	IN2L_TO_MIXINL	0	Left Input IN2L to Left input Boost-Mixer Select 0 = Disabled 1 = Enabled
	4	IN3L_TO_MIXINL	0	Left Input IN3L to Left input Boost-Mixer Select 0 = Disabled 1 = Enabled
	3	INPGAL_TO_MIXINL	1	Left Input PGA to Left input Boost-Mixer Select 0 = Disabled 1 = Enabled

Table 10 Left Input Mixer (MIXINL) Volume Control

REGISTER ADDRESS	BIT	LABEL	DEFAULT	DESCRIPTION
R31 (1Fh) Input mixer control (1)	2	MIXINR_MUTE	0	Right input boost-mixer mute 0 = Un-mute 1 = Mute
R33 (21h) Right input mixer volume	8:6	IN2R_MIXINR_VOL [2:0]	101	Right input IN2R to Right input Boost-Mixer Gain 000 = -12dB 001 = -12dB 010 = -9dB 011 = -6dB 100 = -3dB 101 = 0dB 110 = +3dB 111 = +6dB

REGISTER ADDRESS	BIT	LABEL	DEFAULT	DESCRIPTION
	5:3	INPGAR_MIXINR_VOL [2:0]	000	Right input PGA to Right input Boost-Mixer Gain 000 = 0dB 001 = +6dB 010 = +13dB 011 = +18dB 100 = +20dB 101 = +24dB 110 = +27dB 111 = +29dB
	2:0	IN3R_MIXINR_VOL [2:0]	101	Right input IN3R to Right input Boost-Mixer Gain 000 = -12dB 001 = -12dB 010 = -9dB 011 = -6dB 100 = -3dB 101 = 0dB 110 = +3dB 111 = +6dB
R34 (22h) Input mixer control (2)	2	IN2R_TO_MIXINR	0	Right input IN2R to Right input Boost-Mixer Select 0 = Disabled 1 = Enabled
	1	IN3R_TO_MIXINR	0	Right input IN3R to Right input Boost-Mixer Select 0 = Disabled 1 = Enabled
	0	INPGAR_TO_MIXINR	1	Right input PGA to Right input Boost-Mixer Select 0 = Disabled 1 = Enabled

Table 11 Right Input Mixer (MIXINR) Volume Control

AUTOMATIC LEVEL CONTROL (ALC)

The WM8962B has an automatic PGA gain control circuit that keeps a constant recording volume irrespective of the input signal level. This is achieved by continuously adjusting the input PGA gain so that the signal level at the ADC input remains constant.

A digital peak detector monitors the ADC output and changes the PGA gain if necessary.

The ALC has two modes selected by the ALC_MODE register. See the “Limiter Mode” section for further details on the ALC Modes.

The ALC also has a Noise Gate function, which provides additional control of low level input signals. This means that the signal path is quiet when no signal is present, giving an improvement in background noise level.

The Automatic Level Control (ALC) can be enabled on either the left channel, or the right channel, or on both channels, using the ALCL_ENA and ALCR_ENA fields respectively. Note that the ALC (Left) function requires the Left and Right ADCs to be enabled; the ALC (Right) function only requires the Right ADC to be enabled.

Note that, when disabling the input signal path, the ALC must be disabled before the respective ADCs are disabled. If this sequence is not followed, then the Input PGA gain settings may become fixed.

The ALC should not be enabled when using the IN2 or IN3 inputs connected directly to the input boost mixer; this is because these paths will bypass the PGAs where the ALC gain adjustment is performed.

ALC can be set to Active Mode or to Monitor Mode. When ALC is in Active Mode (ALC_INACTIVE_ENA = 0), the gain of the analogue PGAs is controlled by the ALC bit settings, and not by the INL_VOL or the INR_VOL fields. When ALC is in Monitor Mode (ALC_INACTIVE_ENA=1), ALC monitors the signal levels without doing any of the level control that it would otherwise perform. Details on readback of the ALC status are in the “ALC Status Readback” section.

When the ALC is enabled, a target level for the analogue input signal at the ADC is determined by the ALC_LVL setting. There are two ranges (high or low) from which the ALC_LVL target value can be taken. The target values in each of these ranges are shown in Table 13. Two ranges can be selected using ALC_LVL_MODE. Set ALC_LVL_MODE to 0 to use the low range (-28.5dBFS to -6dBFS), or set ALC_LVL_MODE to 1 to use the higher range (-22.5dBFS to -1.5dBFS).

REGISTER ADDRESS	BIT	LABEL	DEFAULT	DESCRIPTION
R17 (11h) ALC1	10	ALC_INACTIVE_ENA	0	Select whether the ALC is in Active Mode (that is, ALC is controlling the PGA gain) or in Monitor Mode (the analogue controls are disabled). Note that at least one of ALCL_ENA and ALCR_ENA must also be enabled 0 = ALC is in Active Mode 1 = ALC is in Monitor Mode
	9	ALC_LVL_MODE	0	Select the range of the ALC target level. 0 = -28.5dBFS to -6dBFS in 1.5dB steps 1 = -22.5dBFS to -1.5dBFS in 1.5dB steps
	8	ALCL_ENA	0	Select ALC on the Left channel 0 = Disabled (PGA gain set by INL_VOL) 1 = Enabled Note that in stereo mode, the left and right PGA volumes, and left and right boost mixer volumes, must be the same before setting ALCL_ENA = 1 and ALCR_ENA = 1
	7	ALCR_ENA	0	Select ALC on the Right channel 0 = Disabled (PGA gain set by INR_VOL) 1 = Enabled Note that in stereo mode, the left and right PGA volumes, and left and right boost mixer volumes, must be the same before setting ALCL_ENA = 1 and ALCR_ENA = 1
	3:0	ALC_LVL [3:0]	1011	Set the Target signal level at the ADC input. Note that the target level is also determined by ALC_LVL_MODE. ALC_LVL_MODE = 0 0000 = -28.5dBFS 0001 = -27.0dBFS ...in 1.5dB steps to... 1111 = -6dBFS ALC_LVL_MODE = 1 0000 = -22.5dBFS 0001 = -21.0dBFS ...in 1.5dB steps to... 1110 = -1.5dBFS 1111 = -1.5dBFS See Table 13 for the range of possible values.

Table 12 Automatic Level Control

ALC_LVL	ALC_LVL_MODE = 0 (dBFS)	ALC_LVL_MODE = 1 (dBFS)
0000	-28.5	-22.5
0001	-27.0	-21.0
0010	-25.5	-19.5
0011	-24.0	-18.0
0100	-22.5	-16.5
0101	-21.0	-15.0
0110	-19.5	-13.5
0111	-18.0	-12.0
1000	-16.5	-10.5
1001	-15.0	-9.0
1010	-13.5	-7.5
1011	-12.0	-6.0
1100	-10.5	-4.5
1101	-9.0	-3.0
1110	-7.5	-1.5
1111	-6.0	-1.5

Table 13 ALC Target Level Values
LIMITER MODE

In Normal Mode (ALC_MODE = 0), the ALC will attempt to maintain a constant signal level by increasing or decreasing the gain of the PGA. This is illustrated in Figure 19.

In Limiter Mode (ALC_MODE = 1), the ALC will reduce peaks that go above the threshold level, but will not increase the PGA gain beyond the starting level. (The starting level is defined as the gain setting of the PGA at the time when the ALC is enabled.) This is illustrated in Figure 20.

Note that ALC_MODE should not be changed while the ALC is active. ALCL_ENA and ALCR_ENA must both be set to 0 before changing ALC_MODE.

REGISTER ADDRESS	BIT	LABEL	DEFAULT	DESCRIPTION
R19 (13h) ALC3	8	ALC_MODE	0	ALC Mode 0 = Normal ALC Mode 1 = Limiter Mode Note that ALCL_ENA and ALCR_ENA must both be set to 0 before changing ALC_MODE, otherwise unexpected behaviour may result.

Table 14 ALC Mode Switch (ALC_MODE)

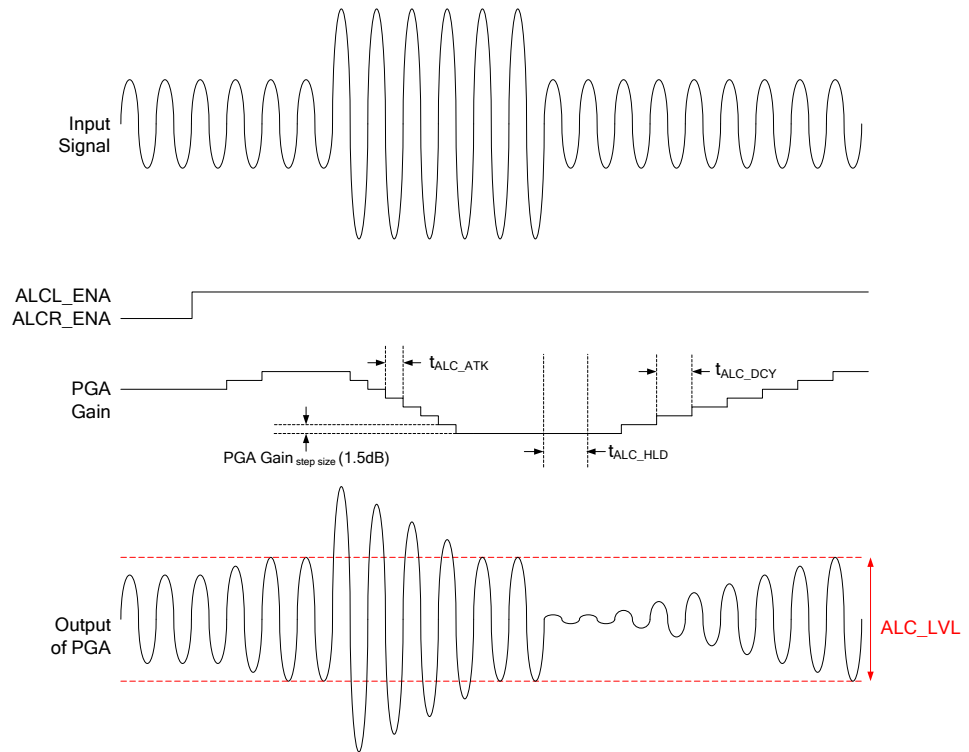
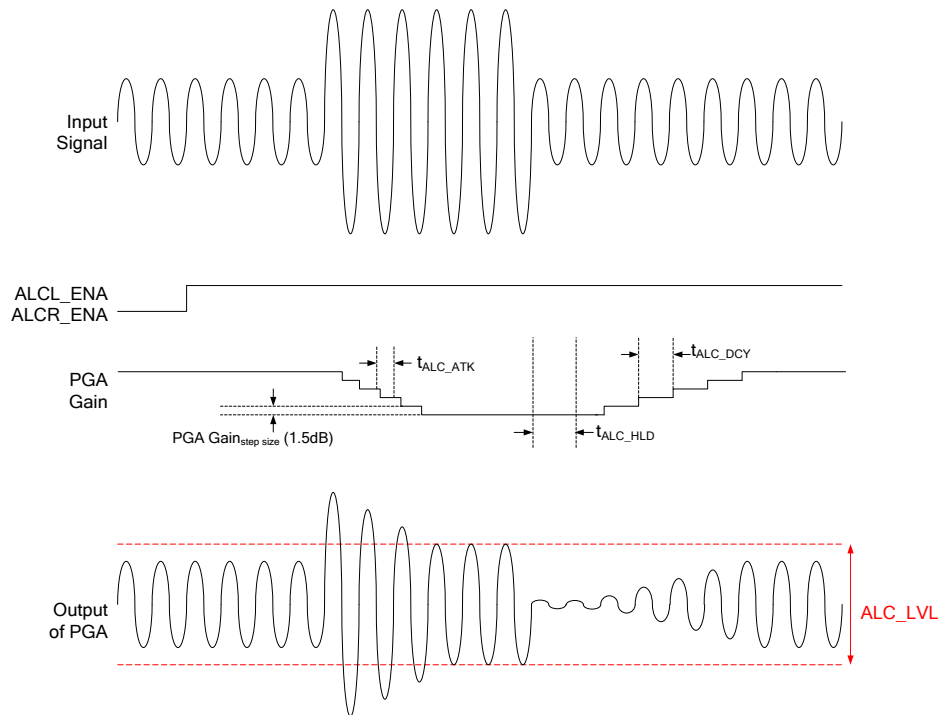
Figure 19 ALC Normal Mode Operation

Figure 20 ALC Limiter Mode Operation

ALC GAIN CONTROL

The minimum and maximum gain applied by the ALC is set by register fields ALC_MINGAIN and ALC_MAXGAIN respectively. These limits can be used to alter the ALC response from that illustrated in Figure 19 and Figure 20. If the range between maximum and minimum gain is reduced, then the extent of the automatic level control is reduced.

Note that, when the ALC is first enabled, the PGA gain (in dB) must be less than the ALC_MAXGAIN setting. The PGA gain is controlled by the INL_VOL and INR_VOL registers, as described in Table 7.

The minimum gain in the ALC response is set by ALC_MINGAIN. The minimum gain limit can be used to prevent excessive attenuation of the signal path.

The maximum gain limit set by ALC_MAXGAIN can be used to prevent quiet signals (or silence) from being excessively amplified. Note that the Noise Gate function also affects quiet signals. See the “ALC Noise Gate” section (below) for further details on the Noise Gate.

To prevent “zipper noise”, a zero-cross function is provided within the ALC. When this feature is enabled, volume updates will not take place until a zero-crossing is detected. In the case of a long period without zero-crossings, a timeout function is provided. When the zero-cross function is enabled, the volume will update after the timeout period if no earlier zero-cross has occurred. The timeout clock is enabled using TOCLK_ENA. See “Clocking and Sample Rates” for the definition of this bit. Note that the zero-cross function can be supported without TOCLK enabled, but the timeout function will not be provided in this case.

When operating in stereo, the peak detector takes the maximum of left and right channel peak values, and any new gain setting is applied equally to both left and right PGAs so that the stereo image is preserved. The input PGA and Input Mixer gain settings should be identical when entering ALC stereo mode in order for gain updates to be applied correctly.

The ALC function can also be enabled on one channel only. In this case, only one PGA is controlled by the ALC mechanism, while the other channel runs independently with its PGA gain set through the control register.

When one ALC channel is unused, the peak detector disregards that channel.

REGISTER ADDRESS	BIT	LABEL	DEFAULT	DESCRIPTION
R17 (11h) ALC1	6:4	ALC_MAXGAIN [3:0]	111	Maximum ALC gain 000 = -18dB 001 = -12dB 010 = -6dB 011 = 0dB 100 = +6dB 101 = +12dB 110 = +18dB 111 = +24dB
R18 (12h) ALC2	7	ALC_ZC	0	ALC Zero Cross Detector 0 = Change gain immediately 1 = Change gain on zero cross only
	6:4	ALC_MINGAIN [3:0]	000	Minimum ALC gain 000 = -23.25dB 001 = -17.25dB 010 = -11.25dB 011 = -5.25dB 100 = +0.75dB 101 = +6.75dB 110 = +12.75dB 111 = +18.75dB

Table 15 ALC Gain Limits

ALC DYNAMIC CHARACTERISTICS

The dynamic behaviour determines how quickly the ALC responds to changing signal levels. Note that the ALC responds to the average (RMS) signal amplitude over a period of time.

The ALC_HLD field selects a delay between the detection of a peak signal level that is below the ALC target level, and the start of the PGA gain ramping up. ALC_HLD can be set to any of the times shown in Table 16. ALC_HLD only affects the gain ramp-up on a low level signal. There is no delay in ramping the gain down when the signal level is above the target level. Note that it is only the start of the gain ramp-up that is affected by the ALC_HLD setting; once the ramp-up has started, it proceeds at the pace dictated by the ALC_DCY setting.

The ALC_DCY field determines how quickly the ALC gain increases when the signal amplitude is low. The times specified are for the time taken per step of applied gain. The actual time taken for the recording level to return to its target level therefore depends on both the decay rate and the gain adjustment required. If the required gain change is small, then the total decay time will be shorter than when a larger gain change is required.

The ALC_ATK field determines how quickly the ALC gain decreases when the signal amplitude is high. The times specified are for the time taken per step of applied attenuation. The actual time taken for the recording level to return to its target level therefore depends on both the attack rate and the gain adjustment required. If the required gain change is small, then the total decay time will be shorter than when a larger gain change is required.

These register fields are described in Table 16.

The SAMPLE_RATE register field must be set correctly to ensure that the ALC attack, decay and hold times are correct for the chosen sample rate. See the "Clocking and Sample Rates" section for further details of this register.

REGISTER ADDRESS	BIT	LABEL	DEFAULT	DESCRIPTION
R18 (12h) ALC2	3:0	ALC_HLD [3:0]	0000	ALC Hold time before the gain ramp-up starts 0000 = 0.00ms 0001 = 2.67ms 0010 = 5.33ms 0011 = 10.7ms 0100 = 21.3ms 0101 = 42.7ms 0110 = 85.3ms 0111 = 171ms 1000 = 341ms 1001 = 683ms 1010 = 1.37s 1011 = 2.73s 1100 = 5.46s 1101 = 10.9s 1110 = 21.8s 1111 = 43.7s

REGISTER ADDRESS	BIT	LABEL	DEFAULT	DESCRIPTION
R19 (13h) ALC3	7:4	ALC_DCY [3:0]	0011	<p>Sets the Gain Decay Rate (measured in time per 1.5dB step). If ALC_MODE = 0 0000 = 0.41ms / step 0001 = 0.82ms / step ...doubling with each step to... 1010 = 420ms / step 1011 = 840ms / step 1100 to 1111 = Reserved</p> <p>If ALC_MODE = 1 0000 = 0.082ms / step 0001 = 0.164ms / step ...doubling with each step to... 1010 = 83.9ms / step 1011 = 168ms / step 1100 to 1111 = Reserved</p> <p>Note that when 88.2kHz or 96kHz sample rate is selected, the Gain Decay time is defined as for the ALC_MODE=0 case above. See Table 17 for further details.</p>
	3:0	ALC_ATK [3:0]	0010	<p>Sets the Gain Attack Rate (measured in time per 1.5dB step). If ALC_MODE = 0 0000 = 0.104ms / step 0001 = 0.208ms / step ...doubling with each step to... 1010 = 106ms / step 1011 to 1111 = Reserved</p> <p>If ALC_MODE = 1 0000 = 0.020ms / step 0001 = 0.041ms / step ...doubling with each step to... 1010 = 21.0ms / step 1011 to 1111 = Reserved</p> <p>Note that when 88.2kHz or 96kHz sample rate is selected, the Gain Attack time is defined as for the ALC_MODE=0 case above. See Table 18 for further details.</p>

Table 16 ALC Time Constants

ALC_DCY, ALC_NGATE_DCY	ALC_MODE = 0	ALC_MODE = 1, SAMPLE_RATE ≤ 48kHz	ALC_MODE = 1, SAMPLE_RATE > 48kHz
0000	0.41ms	0.082ms	0.41ms
0001	0.82ms	0.164ms	0.82ms
0010	1.64ms	0.328ms	1.64ms
0011	3.28ms	0.655ms	3.28ms
0100	6.56ms	1.31ms	6.56ms
0101	13.1ms	2.62ms	13.1ms
0110	26.2ms	5.24ms	26.2ms
0111	52.5ms	10.5ms	52.5ms
1000	105ms	21.0ms	105ms
1001	210ms	41.9ms	210ms
1010	420ms	83.9ms	420ms
1011	840ms	168ms	840ms

Table 17 ALC Decay Rate (Time per 1.5dB Gain Step)

ALC_ATK, ALC_NGATE_ATK	ALC_MODE = 0	ALC_MODE = 1, SAMPLE_RATE ≤ 48kHz	ALC_MODE = 1, SAMPLE_RATE > 48kHz
0000	0.104ms	0.020ms	0.104ms
0001	0.208ms	0.041ms	0.208ms
0010	0.416ms	0.082ms	0.416ms
0011	0.832ms	0.164ms	0.832ms
0100	1.66ms	0.328ms	1.66ms
0101	3.33ms	0.655ms	3.33ms
0110	6.66ms	1.31ms	6.66ms
0111	13.3ms	2.62ms	13.3ms
1000	26.6ms	5.24ms	26.6ms
1001	53.2ms	10.5ms	53.2ms
1010	106ms	21.0ms	106ms

Table 18 ALC Attack Rate (Time per 1.5dB Gain Step)

PEAK LIMITER

To prevent clipping when a large signal occurs just after a period of quiet, the ALC circuit includes a limiter function. If the ADC input signal exceeds 87.5% of full scale (−1.16dBFS), the PGA gain is ramped down at the maximum attack rate (as when ALC_ATK = 0000), until the signal level falls below 87.5% of full scale. This function is automatically enabled whenever the ALC is in Active Mode, but has no effect when ALC is in Monitor Mode.

Note that if ALC_ATK = 0000, then the peak limiter makes no difference to the operation of the ALC; ALC_ATK is already at 0000 and the ALC is therefore already ramping down at its maximum rate. The Peak Limiter is designed to prevent clipping when long attack times are used.

ALC NOISE GATE

To avoid 'noise pumping' when the signal is very quiet and consists mainly of noise, the ALC function has a noise gate function. This prevents noise pumping by comparing the signal level at the input pins against a noise gate threshold, ALC_NGATE_THR. The noise gate cuts in when:

$$\text{Signal level at ADC [dB]} < \text{ALC_NGATE_THR [dB]} + \text{PGA gain [dB]} + \text{Input Mixer gain [dB]}$$

This is equivalent to:

$$\text{Signal level at input pin [dB]} < \text{ALC_NGATE_THR [dB]}$$

Whenever the signal level at the input pins drops below the Noise Gate Threshold (ALC_NGATE_THR), the ALC Noise Gate is activated in one of three modes. The Noise Gate Mode is selected by ALC_NGATE_MODE. As soon as the peak input signal level drops below the Noise Gate Threshold, control of the PGA gain is passed from the ALC to the Noise Gate system.

The Noise Gate modes are:

- Mode 00: The PGA Gain remains static while the input signal is below the ALC Noise Gate Threshold (ALC_NGATE_THR) level.

As soon as the input signal rises back above the ALC Noise Gate Threshold, PGA gain is once again controlled by the ALC.

- Mode 01: The PGA Gain is muted while the input signal is below the ALC Noise Gate Threshold (ALC_NGATE_THR) level. The muting of the PGA Gain is immediate (a hard mute), and is performed by setting ADCL_VOL or ADCR_VOL or both to zero. Note that with Mode 01, it is the ADCL_VOL and ADCR_VOL registers that are muted, and not the INL_VOL and INR_VOL registers that are changed in the other modes.

As soon as the input signal rises back above the ALC Noise Gate Threshold, ADCL_VOL and ADCR_VOL are restored to their previous values. Again this is immediate (a hard unmute).

- Mode 10: The PGA Gain is either ramped down to the ALC_NGATE_GAIN at a rate determined by ALC_NGATE_ATK, or ramped up to the ALC_NGATE_GAIN level at a rate determined by ALC_NGATE_DCY.

As soon as the input signal rises back above the ALC Noise Gate Threshold, PGA gain is once again controlled by the ALC. The PGA gain is ramped up (or down) at a rate determined by ALC_DCY (or ALC_ATK).

The noise gate control register is described in Table 19. The ALC_NGATE_THR variable sets the Noise Gate threshold with respect to the ADC full-scale range. The threshold is adjusted in 1.5dB steps. Levels at the extremes of the range may cause inappropriate operation, so care should be taken with set-up of the function. Note that the Noise Gate only works in conjunction with the ALC function, and always operates on the same channel(s) as the ALC (left, right, both, or none).

REGISTER ADDRESS	BIT	LABEL	DEFAULT	DESCRIPTION
R19 (13h) ALC3	12:10	ALC_NGATE_GAIN [2:0]	111	Noise Gate Gain level. This is the PGA gain level used within the ALC Noise Gate function. 000 = -23.25dB 001 = -18dB 010 = -12dB 011 = -6dB 100 = 0dB 101 = +6dB 110 = +12dB 111 = +18dB
R20 (14h) Noise Gate	15:12	ALC_NGATE_DCY [3:0]	0011	Sets the Noise Gate Gain Decay Rate (time taken to ramp up to the ALC_NGATE_GAIN level), measured in time per 1.5dB step. If ALC_MODE = 0 0000 = 0.41ms / step 0001 = 0.82ms / step ...doubling with each step to... 1010 = 420ms / step 1011 = 840ms / step 1100 to 1111 = Reserved If ALC_MODE = 1 0000 = 0.082ms / step 0001 = 0.164ms / step ...doubling with each step to... 1010 = 83.9ms / step 1011 = 168ms / step 1100 to 1111 = Reserved Note that when 88.2kHz or 96kHz sample rate is selected, the Noise Gate Gain Decay time is defined as for the ALC_MODE=0 case above. See Table 17 for further details.

REGISTER ADDRESS	BIT	LABEL	DEFAULT	DESCRIPTION
	11:8	ALC_NGATE_ATK [3:0]	0010	<p>Sets the Gain Attack Rate (time taken to ramp down to the ALC_NGATE_GAIN level), measured in time per 1.5dB step.</p> <p>If ALC_MODE = 0 0000 = 0.10ms / step 0001 = 0.21ms / step ...doubling with each step to... 1010 = 106ms / step 1011 to 1111 = Reserved</p> <p>If ALC_MODE = 1 0000 = 0.020ms / step 0001 = 0.041ms / step ...doubling with each step to... 1010 = 21.0ms / step 1011 to 1111 = Reserved</p> <p>Note that when 88.2kHz or 96kHz sample rate is selected, the Noise Gain Attack time is defined as for the ALC_MODE=0 case above. See Table 18 for further details.</p>
	7:3	ALC_NGATE_THR [4:0]	0_0000 (-76.5dBFS)	Noise Gate Threshold. If the input signal falls below this level, the Noise Gate function is triggered. -76.5dB to -30dB in 1.5dB steps. See Table 20 for further details.
	2:1	ALC_NGATE_MODE [1:0]	00	<p>Noise gate mode 00 = Hold PGA gain static when noise gate triggers 01 = Mute ADC output immediately when noise gate triggers. 10 = Ramp PGA Gain to ADC_NGATE_GAIN level when Noise Gate triggers. 11 = Reserved</p>
	0	ALC_NGATE_ENA	0	Noise Gate function enable 0 = Disable 1 = Enable

Table 19 ALC Noise Gate Control

ALC_NGATE_THR [4:0]	THRESHOLD (dBFS)
0_0000	-76.5
0_0001	-75.0
0_0010	-73.5
0_0011	-72.0
0_0100	-70.5
0_0101	-69.0
0_0110	-67.5
0_0111	-66.0
0_1000	-64.5
0_1001	-63.0
0_1010	-61.5
0_1011	-60.0
0_1100	-58.5
0_1101	-57.0
0_1110	-55.5
0_1111	-54.0
1_0000	-52.5
1_0001	-51.0
1_0010	-49.5
1_0011	-48.0
1_0100	-46.5
1_0101	-45.0
1_0110	-43.5
1_0111	-42.0
1_1000	-40.5
1_1001	-39.0
1_1010	-37.5
1_1011	-36.0
1_1100	-34.5
1_1101	-33.0
1_1110	-31.5
1_1111	-30.0

Table 20 ALC Noise Gate Threshold (ALC_NGATE_THR) Settings

ALC STATUS READBACK

There are five ALC status registers that provide monitoring of the Automatic Level Control (ALC). These are particularly useful when ALC is in Monitor Mode (ALC_INACTIVE_ENA = 1), and the PGA Gains are not being changed by the ALC.

These five Register bits and their settings are summarised in Table 21.

REGISTER ADDRESS	BIT	LABEL	DEFAULT	DESCRIPTION
R18 (12h) ALC2	15	ALC_LOCK_STS	0	Readback of the ALC Lock Status. Set when ADC signal = ALC_LVL
	14	ALC_THRESH_STS	0	Readback of the ALC Threshold Level status (when ALC_LOCK_STS = 0) 0 = ADC signal < ALC_LVL 1 = ADC signal > ALC_LVL
	13	ALC_SAT_STS	0	Readback of the ALC saturation status. 0 = ADC signal = ALC_LVL 1 = ADC signal < ALC_LVL but maximum ALC Gain has been reached
	12	ALC_PKOVR_STS	0	Readback of the ALC Peak Limiter Overload status. Set when ADC input signal exceeds -1.16dBFS
	11	ALC_NGATE_STS	0	Readback of the ALC Noise Gate status. 0 = ADC input signal level > ALC_NGATE_THR 1 = ADC input signal level < ALC_NGATE_THR

Table 21 ALC Status Readback

DIGITAL MICROPHONE INTERFACE

The WM8962B supports a stereo digital microphone interface. Two channels of audio data are multiplexed on a GPIO pin configured for digital microphone input.

The digital microphone data input (DMICDAT) is provided on GPIO5 or GPIO6 by setting the respective GPN_FN register to 1_0100. The associated clock (DMICCLK) is provided on a separate GPIO pin by setting the respective GPN_FN register to 1_0011. See “General Purpose Input/Output (GPIO)” section for details on these registers.

Note that care must be taken to ensure that the respective digital logic levels of the microphone are compatible with the digital input thresholds of the WM8962B. The digital input thresholds are referenced to DBVDD, as defined in “Electrical Characteristics”. It is recommended to power the digital microphones from DBVDD.

When digital microphone input is enabled, the WM8962B outputs a clock signal (DMICCLK) on the Digital Microphone Clock Output pin (this must be configured on one of the GPIO pins). The clock frequency for all supported digital microphone clocking modes is described later in this section.

A pair of digital microphones is connected as illustrated in Figure 21. The microphones must be configured to ensure that the Left mic transmits a data bit when DMICCLK is high, and the Right mic transmits a data bit when DMICCLK is low. The WM8962B samples the digital microphone data at the end of each DMICCLK phase. Each microphone must tri-state its data output when the other microphone is transmitting.

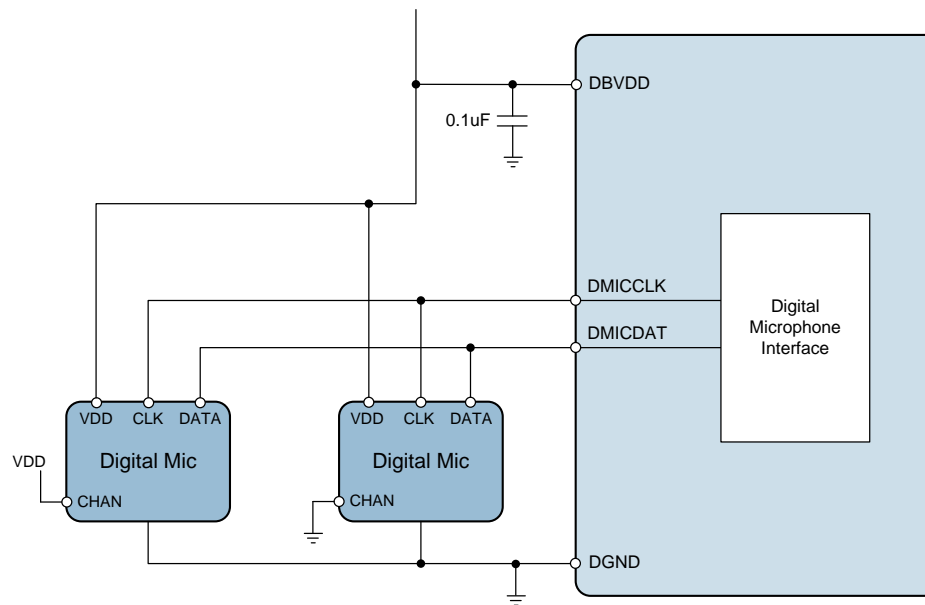

DMICCLK is available on GPIO2, GPIO3, GPIO5 and GPIO6
DMICDAT is supported on GPIO5 and GPIO6

Figure 21 Digital Microphone Input

The digital microphone signal paths are enabled using the DMIC_ENA register. When DMIC_ENA is set, the ADC path is disconnected and the digital microphone data is routed to the digital core, as illustrated in “Digital Mixing”.

Two microphone channels are interleaved on DMICDAT; the timing is illustrated in Figure 22. Each microphone must tri-state its data output when the other microphone is transmitting.

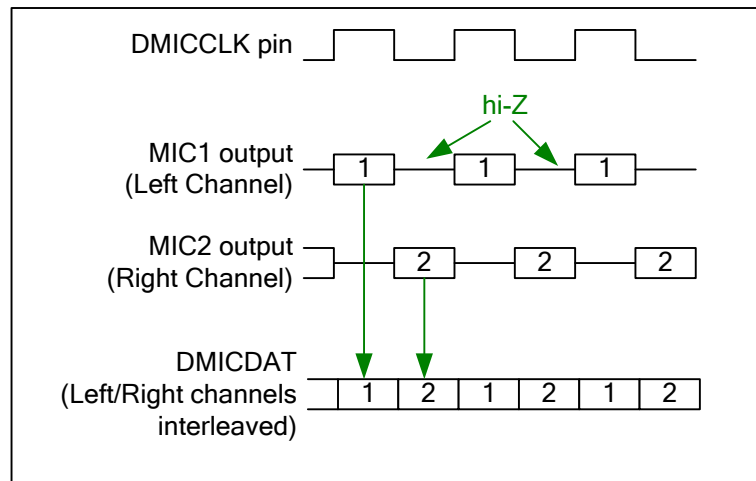

Figure 22 Digital Microphone Interface Timing

The digital microphone interface control fields are described in Table 22. Note that the ADC and Record Path filters must be enabled and the sample rate must be set in order to ensure correct operation of all DSP functions associated with the digital microphone. Volume control for the Digital Microphone Interface signals is provided using the ADC Volume Control.

See “Analogue To Digital Converter (ADC)” for details of the ADC Enable and ADC digital volume control functions. See “General Purpose Input/Output (GPIO)” for details of configuring the DMICCLK and DMICDAT functions. See “Clocking and Sample Rates” for details of the sample rate control.

REGISTER ADDRESS	BIT	LABEL	DEFAULT	DESCRIPTION
R25 (19h) Pwr Mgmt (1)	10	DMIC_ENA	0	Enables Digital Microphone mode. 0 = Audio DSP input is from ADC 1 = Audio DSP input is from digital microphone interface Note that, when the digital microphone interface is selected, the ADCL_ENA and ADCR_ENA registers must also be set to enable the left and right digital microphone channels respectively.
	3	ADCL_ENA	0	Left ADC Enable 0 = Disabled 1 = Enabled
	2	ADCR_ENA	0	Right ADC Enable 0 = Disabled 1 = Enabled

Table 22 Digital Microphone Interface Control

Note that, in addition to setting the DMIC_ENA bit as described in Table 22, the pins GPIO2, GPIO3, GPIO5 or GPIO6 must also be configured to provide the digital microphone interface function. See “General Purpose Input/Output (GPIO)” for details.

Clocking for the digital microphone interface is derived from SYSCLK. The DMICCLK frequency is configured automatically, according to the SAMPLE_RATE, MCLK_RATE, and ADC_HP registers. (See “Clocking and Sample Rates” for further details of the system clocks and control registers.)

The DMICCLK is enabled whenever a digital microphone input path is enabled on the GPIO2 or GPIO3 pins. Note that the SYSCLK_ENA register must also be set.

The DMICCLK frequency is as described in Table 23 (for ADC_HP=0) and Table 24 (for ADC_HP=1). The ADC_HP bit is set to 0 by default, giving reduced power consumption. Note that the only valid DMICCLK configurations are the ones listed in Table 23 and Table 24.

Note that the system clock, SYSCLK, must be present and enabled when using the digital microphone interface.

SAMPLE RATE (kHz)	MCLK RATE (MCLK / fs ratio)							
	256	384	512	768	1024	1536	3072	6144
8	1.024		1.024	1.024	1.024	1.024	1.024	1.024
11.025	1.4112		1.4112	1.4112	1.4112	1.4112	1.4112	
12	1.536		1.536	1.536	1.536	1.536	1.536	
16	1.024	1.024	1.024	1.024	1.024	1.024	1.024	
22.05	1.4112	1.4112	1.4112	1.4112	1.4112	1.4112		
24	1.536	1.536	1.536	1.536	1.536	1.536		
32	2.048	2.048	2.048	2.048	2.048	2.048		
44.1	2.8224	1.4112	2.8224	1.4112	2.8224			
48	3.072	1.536	3.072	1.536	3.072			
88.2	2.8224		2.8224					
96	3.072		3.072					

When ADC_HP=0, digital microphone operation is only supported for the above configurations. Digital microphone operation is not supported for 64fs, 128fs or 192fs MCLK ratios.

Table 23 DMICCLK Frequency (MHz) - ADC_HP = 0 (Default)

SAMPLE RATE (kHz)	MCLK RATE (MCLK / fs ratio)							
	256	384	512	768	1024	1536	3072	6144
8	1.024		2.048		2.048	2.048	2.048	2.048
11.025	1.4112		2.8224		2.8224			
12	1.536		3.072		3.072			
16	2.048			2.048	2.048	2.048	2.048	
22.05	2.8224		2.8224		2.8224			
24	3.072		3.072		3.072			
32	2.048		2.048		2.048			
44.1	2.8224		2.8224		2.8224			
48	3.072		3.072		3.072			
88.2	2.8224		2.8224					
96	3.072		3.072					

When ADC_HP=1, digital microphone operation is only supported for the above configurations. Digital microphone operation is not supported for 64fs, 128fs or 192fs MCLK ratios.

Table 24 DMICCLK Frequency (MHz) - ADC_HP = 1

ANALOGUE TO DIGITAL CONVERTER (ADC)

The WM8962B uses stereo 24-bit, 128x oversampled sigma-delta ADCs. The use of multi-bit feedback and high oversampling rates reduces the effects of jitter and high frequency noise. The ADC full scale input level is proportional to AVDD - see "Electrical Characteristics". Any input signal greater than full scale may overload the ADC and cause distortion.

The ADCs are enabled by the ADCL_ENA and ADCR_ENA register bits. Note that when disabling the ADC, the digital volume controls ADCL_VOL and ADCR_VOL should be muted before clearing ADCL_ENA or ADCR_ENA to 0. This ensures that the last ADC code does not appear at the Audio Interface (ADCDAT) pin when ADCL_ENA or ADCR_ENA are cleared.

REGISTER ADDRESS	BIT	LABEL	DEFAULT	DESCRIPTION
R25 (19h) Pwr Mgmt (1)	3	ADCL_ENA	0	Left ADC Enable 0 = Disabled 1 = Enabled
	2	ADCR_ENA	0	Right ADC Enable 0 = Disabled 1 = Enabled

Table 25 ADC Enable Control

ADC CLOCKING CONTROL

Clocking for the ADCs is derived from SYSCLK. The required clock is enabled when the SYSCLK_ENA register is set.

The ADC clock rate is configured automatically, according to the SAMPLE_RATE and MCLK_RATE registers. See "Clocking and Sample Rates" for further details of the system clocks and associated control registers.

Note that the ADC and the ADC signal path enhancements functions are only supported under specific clocking configurations. The valid clocking ratios for ADC operation are identified in Table 96. See also Table 97 for details of the supported functions for different MCLK / fs ratios.

ADC DIGITAL VOLUME CONTROL

The output of the ADCs can be digitally amplified or attenuated over a range from -71.625dB to +23.625dB in 0.375dB steps. The volume of each channel can be controlled separately. The gain for a given eight-bit code X is given by:

$$0.375 \times (X-192) \text{ dB for } 1 \leq X \leq 255; \quad \text{MUTE for } X = 0$$

The ADC_VU bit controls the loading of digital volume control data. When ADC_VU is set to 0, the ADCL_VOL or ADCR_VOL control data will be loaded into the respective control register, but will not actually change the digital gain setting. Both left and right gain settings are updated when a 1 is written to ADC_VU. This makes it possible to update the gain of both channels simultaneously.

REGISTER ADDRESS	BIT	LABEL	DEFAULT	DESCRIPTION
R21 (15h) Left ADC Volume	8	ADC_VU	N/A	ADC Volume Update Writing a 1 to this bit will cause left and right ADC volume to be updated simultaneously
	7:0	ADCL_VOL [7:0]	C0h (0dB)	Left ADC Digital Volume 00h = mute 01h = -71.625dB 02h = -71.250dB ...0.375dB steps C0h = 0dB (default) ... FFh = 23.625dB (See Table 27 for volume range)
R22 (16h) Right ADC Volume	8	ADC_VU	N/A	ADC Volume Update Writing a 1 to this bit will cause left and right ADC volume to be updated simultaneously
	7:0	ADCR_VOL [7:0]	C0h (0dB)	Right ADC Digital Volume 00h = mute 01h = -71.625dB 02h = -71.250dB ...0.375dB steps C0h = 0dB (default) ... FFh = 23.625dB (See Table 27 for volume range)

Table 26 ADC Digital Volume Control

ADCL_VOL or ADCR_VOL	Volume (dB)	ADCL_VOL or ADCR_VOL	Volume (dB)	ADCL_VOL or ADCR_VOL	Volume (dB)	ADCL_VOL or ADCR_VOL	Volume (dB)
00	MUTE	40	-48.000	80	-24.000	C0	0.000
01	-71.625	41	-47.625	81	-23.625	C1	0.375
02	-71.250	42	-47.250	82	-23.250	C2	0.750
03	-70.875	43	-46.875	83	-22.875	C3	1.125
04	-70.500	44	-46.500	84	-22.500	C4	1.500
05	-70.125	45	-46.125	85	-22.125	C5	1.875
06	-69.750	46	-45.750	86	-21.750	C6	2.250
07	-69.375	47	-45.375	87	-21.375	C7	2.625
08	-69.000	48	-45.000	88	-21.000	C8	3.000
09	-68.625	49	-44.625	89	-20.625	C9	3.375
0A	-68.250	4A	-44.250	8A	-20.250	CA	3.750
0B	-67.875	4B	-43.875	8B	-19.875	CB	4.125
0C	-67.500	4C	-43.500	8C	-19.500	CC	4.500
0D	-67.125	4D	-43.125	8D	-19.125	CD	4.875
0E	-66.750	4E	-42.750	8E	-18.750	CE	5.250
0F	-66.375	4F	-42.375	8F	-18.375	CF	5.625
10	-66.000	50	-42.000	90	-18.000	D0	6.000
11	-65.625	51	-41.625	91	-17.625	D1	6.375
12	-65.250	52	-41.250	92	-17.250	D2	6.750
13	-64.875	53	-40.875	93	-16.875	D3	7.125
14	-64.500	54	-40.500	94	-16.500	D4	7.500
15	-64.125	55	-40.125	95	-16.125	D5	7.875
16	-63.750	56	-39.750	96	-15.750	D6	8.250
17	-63.375	57	-39.375	97	-15.375	D7	8.625
18	-63.000	58	-39.000	98	-15.000	D8	9.000
19	-62.625	59	-38.625	99	-14.625	D9	9.375
1A	-62.250	5A	-38.250	9A	-14.250	DA	9.750
1B	-61.875	5B	-37.875	9B	-13.875	DB	10.125
1C	-61.500	5C	-37.500	9C	-13.500	DC	10.500
1D	-61.125	5D	-37.125	9D	-13.125	DD	10.875
1E	-60.750	5E	-36.750	9E	-12.750	DE	11.250
1F	-60.375	5F	-36.375	9F	-12.375	DF	11.625
20	-60.000	60	-36.000	A0	-12.000	E0	12.000
21	-59.625	61	-35.625	A1	-11.625	E1	12.375
22	-59.250	62	-35.250	A2	-11.250	E2	12.750
23	-58.875	63	-34.875	A3	-10.875	E3	13.125
24	-58.500	64	-34.500	A4	-10.500	E4	13.500
25	-58.125	65	-34.125	A5	-10.125	E5	13.875
26	-57.750	66	-33.750	A6	-9.750	E6	14.250
27	-57.375	67	-33.375	A7	-9.375	E7	14.625
28	-57.000	68	-33.000	A8	-9.000	E8	15.000
29	-56.625	69	-32.625	A9	-8.625	E9	15.375
2A	-56.250	6A	-32.250	AA	-8.250	EA	15.750
2B	-55.875	6B	-31.875	AB	-7.875	EB	16.125
2C	-55.500	6C	-31.500	AC	-7.500	EC	16.500
2D	-55.125	6D	-31.125	AD	-7.125	ED	16.875
2E	-54.750	6E	-30.750	AE	-6.750	EE	17.250
2F	-54.375	6F	-30.375	AF	-6.375	EF	17.625
30	-54.000	70	-30.000	B0	-6.000	F0	18.000
31	-53.625	71	-29.625	B1	-5.625	F1	18.375
32	-53.250	72	-29.250	B2	-5.250	F2	18.750
33	-52.875	73	-28.875	B3	-4.875	F3	19.125
34	-52.500	74	-28.500	B4	-4.500	F4	19.500
35	-52.125	75	-28.125	B5	-4.125	F5	19.875
36	-51.750	76	-27.750	B6	-3.750	F6	20.250
37	-51.375	77	-27.375	B7	-3.375	F7	20.625
38	-51.000	78	-27.000	B8	-3.000	F8	21.000
39	-50.625	79	-26.625	B9	-2.625	F9	21.375
3A	-50.250	7A	-26.250	BA	-2.250	FA	21.750
3B	-49.875	7B	-25.875	BB	-1.875	FB	22.125
3C	-49.500	7C	-25.500	BC	-1.500	FC	22.500
3D	-49.125	7D	-25.125	BD	-1.125	FD	22.875
3E	-48.750	7E	-24.750	BE	-0.750	FE	23.250
3F	-48.375	7F	-24.375	BF	-0.375	FF	23.625

Table 27 ADC Digital Volume Range

ADC OVERSAMPLING RATIO (OSR)

The ADC oversampling rate is programmable to allow power consumption versus audio performance trade-offs. The default oversampling rate is low for reduced power consumption; using the higher OSR setting improves the DAC signal-to-noise performance.

See the “Reference Voltages and Bias Control” section for details of the supported bias control settings for the input signal paths.

REGISTER ADDRESS	BIT	LABEL	DEFAULT	DESCRIPTION
R23 (17h) Additional control (1)	5	ADC_HP	0	ADC Oversampling Ratio 0 = Low Power (typically 64 x fs) 1 = High Performance (typically 128 x fs)

Table 28 ADC Oversampling Ratio
ADC MONOMIX

A mono mix of the Left and Right channels can be created by setting the ADC_MONOMIX register bit, as described in Table 29. When ADC_MONOMIX is set, 3D Surround must be disabled (THREED_ENA = 0, as described Table 34) for the ADC_MONOMIX setting to be effective. An attenuation of -6dB is applied to the sum of the Left and Right channels in order to avoid clipping.

REGISTER ADDRESS	BIT	LABEL	DEFAULT	DESCRIPTION
R268 (010Ch) THREED1	6	ADC_MONOMIX	0	ADC Monomix enable 0 = Disabled 1 = Enabled Note that THREED_ENA (see Table 34) must be disabled for ADC_MONOMIX to be effective.

Table 29 ADC Monomix

DSP SIGNAL ENHANCEMENTS

The WM8962B incorporates several advanced signal enhancement features within the digital audio signal paths, as illustrated in Figure 23.

The ADC signal path incorporates a 2nd order High-Pass Filter (HPF), 1st order Low/High-Pass Filter (LPF/HPF), 3D surround, DF1 Filter, ReTune™ and Dynamic Range Control (DRC).

The DAC signal path incorporates a 5-Band EQ, Dynamic Range Control (DRC), 2nd order High-Pass Filter (HPF), Virtual Surround Sound (VSS), HD Bass and ReTune™.

Note that ReTune™ can be enabled on the ADC or DAC signal paths; it can also be enabled on both paths at the same time, with unique coefficient sets on each path.

Dynamic Range Control (DRC) can be enabled on either the ADC path or on the DAC path, but not on both at the same time.

Note that specific sequences must be followed when enabling or configuring ADC ReTune, DAC ReTune, DAC 2nd order HPF, VSS, and HD Bass sound enhancement functions. Different control sequences are applicable, depending on whether any of the advanced signal enhancements is initially enabled or not.

The configuration parameters in registers R16896 (4200h) to R21139 (5293h) are 24-bit words, arranged within the 16-bit register address space. Each 24-bit word must be written to the register map in full, MSBs first, before attempting to read back the value. Failure to do this may give incorrect read/write behaviour.

When updating the configuration parameters for any DSP feature(s), it is recommended to write all of the associated registers, in incremental address order, before reading back any values.

ENABLE SEQUENCE - ENHANCEMENTS INITIALLY DISABLED

When enabling any of ADC ReTune, DAC ReTune, DAC 2nd order HPF, VSS, or HD Bass, the following sequence is required.

Note that this sequence assumes that, under initial conditions, all of these enhancement functions are disabled. A separate sequence is described for use when sound enhancement is initially enabled.

1. MCLK must be present and configured at ≥ 512 fs (see Table 99)
2. Set ADCL_VOL = 00h in Register R21 (15h), and ADCR_VOL = 00h in Register R22 (16h) (see Table 26)
3. Set ADCL_ENA = 0 and ADCR_ENA = 0 in Register R25 (19h) (see Table 25)
4. Set DAC_MUTE = 1 in Register R5 (5h) (see Table 63)
5. Set DACL_ENA = 0 and DACR_ENA = 0 in Register R26 (1Ah) (see Table 60)
6. Set DSP2_ENA = 1 in Register R768 (300h) (see Table 30)
7. Set the configuration parameters in registers R16896 (4200h) to R21139 (5293h)
8. Readback the configuration parameters in registers R16896 (4200h) to R21139 (5293h)
9. Set DSP2_RUNR = 1 in Register R1037 (40Dh) (see Table 30)
10. Set the enable bits in Register R16389 (4005h) for any required sound enhancement

RTN_ADC_ENA

RTN_DAC_ENA

HDBASS_ENA

HPF1_ENA (see note below)

HPF2_ENA (see note below)

VSS_ENA

11. Set ADCL_ENA = 1 and ADCR_ENA = 1 in Register R25 (19h), if required (see Table 25)
12. Set ADCL_VOL in Register R21 (15h), and ADCR_VOL in Register R22 (16h), to their previous values
13. Set DACL_ENA = 1 and DACR_ENA = 1 in Register R26 (1Ah), if required (see Table 60)

14. Set DAC_MUTE = 0 in Register R5 (5h) (see Table 63)

Note that the DAC high pass filters cannot be enabled unless one or more other sound enhancement functions is enabled. If HPF1_ENA = 1 or HPF2_ENA = 1, then at least one other of the enable bits in Register R16389 must also be set (ie. RTN_ADC_ENA, RTN_DAC_ENA, HDBASS_ENA or VSS_ENA).

Note that DSP2_ENA in Register R768 (300h) must remain asserted whenever any of the sound enhancement functions listed above is being used.

ENABLE / DISABLE SEQUENCE - ENHANCEMENTS INITIALLY ENABLED

When enabling or disabling any of ADC ReTune, DAC ReTune, DAC 2nd order HPF, VSS, or HD Bass, the following sequence is required.

Note that this sequence assumes that, under initial conditions, one or more of these enhancement functions is enabled. A separate sequence is described for use when the sound enhancements are initially disabled.

Note that this sequence assumes that the applicable enhancement functions have already been configured (using default settings or otherwise). This sequence is only for enabling/disabling the selected functions. Separate sequences are described for configuring any of the sound enhancement functions.

1. Set ADCL_VOL = 00h in Register R21 (15h), and ADCR_VOL = 00h in Register R22 (16h) (see Table 26)
2. Set DAC_MUTE = 1 in Register R5 (5h) (see Table 63)
3. Set the enable bits in Register R16389 (4005h) for any required sound enhancement
 - RTN_ADC_ENA
 - RTN_DAC_ENA
 - HDBASS_ENA
 - HPF1_ENA (see note below)
 - HPF2_ENA (see note below)
 - VSS_ENA
4. Set ADCL_VOL in Register R21 (15h), and ADCR_VOL in Register R22 (16h), to their previous values
5. Set DAC_MUTE = 0 in Register R5 (5h) (see Table 63)

Note that the DAC high pass filters cannot be enabled unless one or more other sound enhancement functions is enabled. If HPF1_ENA = 1 or HPF2_ENA = 1, then at least one other of the enable bits in Register R16389 must also be set (ie. RTN_ADC_ENA, RTN_DAC_ENA, HDBASS_ENA or VSS_ENA).

Note that DSP2_ENA in Register R768 (300h) must remain asserted whenever any of the sound enhancement functions listed above is being used.

To disable all sound enhancement functions, refer to the control sequence described in the next section ("Disable All Sound Enhancements").

DISABLE ALL SOUND ENHANCEMENTS SEQUENCE

When disabling all of the sound enhancement functions (ADC ReTune, DAC ReTune, DAC 2nd order HPF, VSS, and HD Bass), the following sequence is required:

1. Set ADCL_VOL = 00h in Register R21 (15h), and ADCR_VOL = 00h in Register R22 (16h) (see Table 26)
2. Set DAC_MUTE = 1 in Register R5 (5h) (see Table 63)
3. Set the enable bits in Register R16389 (4005h) to 0 for all sound enhancements
 - RTN_ADC_ENA = 0
 - RTN_DAC_ENA = 0
 - HDBASS_ENA = 0
 - HPF1_ENA = 0
 - HPF2_ENA = 0
 - VSS_ENA = 0
4. Set ADCL_VOL in Register R21 (15h), and ADCR_VOL in Register R22 (16h), to their previous values
5. Set DAC_MUTE = 0 in Register R5 (5h) (see Table 63)
6. Set DSP2_STOP = 1 in Register R1037 (40Dh) (see Table 30)
7. Set DSP2_ENA = 0 in Register R768 (300h) (see Table 30).

UPDATE / READBACK SEQUENCE - ENHANCEMENTS INITIALLY ENABLED

The required control sequence to update or read back the configuration parameters differs according to whether one or more of the sound enhancements is enabled under the initial conditions.

If ADC ReTune, DAC ReTune, DAC 2nd order HPF, VSS, or HD Bass is already enabled, then the following sequence is required when updating or reading back the configuration parameters:

1. Set ADCL_VOL = 00h in Register R21 (15h), and ADCR_VOL = 00h in Register R22 (16h) (see Table 26)
2. Set ADCL_ENA = 0 and ADCR_ENA = 0 in Register R25 (19h) (see Table 25)
3. Set DAC_MUTE = 1 in Register R5 (5h) (see Table 63)
4. Set DACL_ENA = 0 and DACR_ENA = 0 in Register R26 (1Ah) (see Table 60)
5. Disable all sound enhancement registers in Register R16389 (4005h)
 - RTN_ADC_ENA = 0
 - RTN_DAC_ENA = 0
 - HDBASS_ENA = 0
 - HPF2_ENA = 0
 - HPF1_ENA = 0
 - VSS_ENA = 0
6. Set DSP2_STOP = 1 in Register R1037 (40Dh) (see Table 30)
7. Set the configuration parameters in registers R16896 (4200h) to R21139 (5293h)
8. Readback the configuration parameters in registers R16896 (4200h) to R21139 (5293h)
9. Set DSP2_RUNR = 1 in Register R1037 (40Dh) (see Table 30)
10. Set the enable bits in Register R16389 (4005h) for any required sound enhancement
 - RTN_ADC_ENA
 - RTN_DAC_ENA
 - HDBASS_ENA
 - HPF1_ENA
 - HPF2_ENA
 - VSS_ENA
11. Set ADCL_ENA = 1 and ADCR_ENA = 1 in Register R25 (19h), if required (see Table 25)
12. Set ADCL_VOL in Register R21 (15h), and ADCR_VOL in Register R22 (16h), to their previous values
13. Set DACL_ENA = 1 and DACR_ENA = 1 in Register R26 (1Ah), if required (see Table 60)
14. Set DAC_MUTE = 0 in Register R5 (5h) (see Table 63)

UPDATE / READBACK SEQUENCE - ENHANCEMENTS INITIALLY DISABLED

The required control sequence to update or read back the configuration parameters differs according to whether one or more of the sound enhancements is enabled under the initial conditions.

If ADC ReTune, DAC ReTune, DAC 2nd order HPF, VSS, or HD Bass are all disabled, then the following sequence is required when updating or reading back the configuration parameters:

1. MCLK must be present and configured at ≥ 512 fs (see Table 99)
2. Set ADCL_VOL = 00h in Register R21 (15h), and ADCR_VOL = 00h in Register R22 (16h) (see Table 26)
3. Set ADCL_ENA = 0 and ADCR_ENA = 0 in Register R25 (19h) (see Table 25)
4. Set DAC_MUTE = 1 in Register R5 (5h) (see Table 63)
5. Set DACL_ENA = 0 and DACR_ENA = 0 in Register R26 (1Ah) (see Table 60)
6. Set DSP2_ENA = 1 in Register R768 (300h) (see Table 30)
7. Set the configuration parameters in registers R16896 (4200h) to R21139 (5293h)
8. Readback the configuration parameters in registers R16896 (4200h) to R21139 (5293h)
9. Set DSP2_ENA = 0 in Register R768 (300h) (see Table 30)
10. Set ADCL_ENA = 1 and ADCR_ENA = 1 in Register R25 (19h), if required (see Table 25)
11. Set ADCL_VOL in Register R21 (15h), and ADCR_VOL in Register R22 (16h), to their previous values
12. Set DACL_ENA = 1 and DACR_ENA = 1 in Register R26 (1Ah), if required (see Table 60)
13. Set DAC_MUTE = 0 in Register R5 (5h) (see Table 63)

The DSP2 audio processor control registers are described in Table 30. Other registers associated with ADC ReTune, DAC ReTune, DAC 2nd order HPF, VSS, or HD Bass are described in the respective sections in the following pages.

REGISTER ADDRESS	BIT	LABEL	DEFAULT	DESCRIPTION
R768 (R300h) DSP2 Power Management	0	DSP2_ENA	0	DSP2 Audio Processor Enable. 0 = Disabled 1 = Enabled This bit must be set before any of ADC ReTune, DAC ReTune, DAC HPF, VSS or HD Bass is enabled. It must remain set whenever any of these functions is enabled.
R1037 (40Dh) DSP2_ExecC onrol	2	DSP2_STOP	N/A	Stop the DSP2 audio processor Writing a 1 to this bit will cause the DSP2 processor to stop processing audio data
	1	DSP2_RUNR	N/A	Start the DSP2 audio processor Writing a 1 to this bit will cause the DSP2 processor to start processing audio data

Table 30 DSP Signal Enhancement Control

ADC SIGNAL PATH ENHANCEMENTS

The ADC signal path incorporates a number of sound enhancement features, as illustrated in Figure 23. These features are described more fully in the following sections.

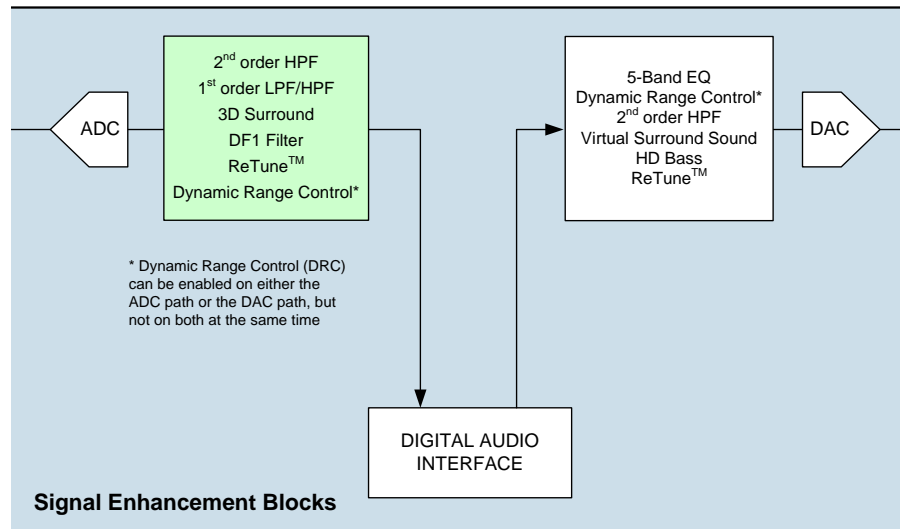
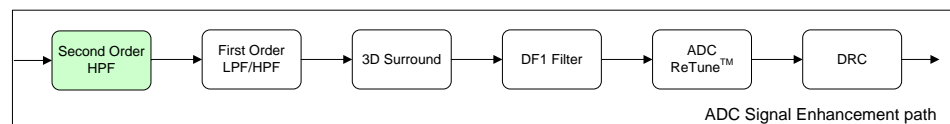

Figure 23 ADC Signal Path Enhancements

ADC SECOND ORDER HIGH-PASS FILTER



A digital high-pass filter is enabled by default in the ADC path to remove DC offsets. This filter can also be used to remove low frequency noise in voice applications (e.g. wind noise or mechanical vibration). The filter can be disabled by setting the ADC_HPF_DIS register bit.

The filter operates in one of two modes, selected by ADC_HPF_MODE.

The ADC_HPF_SR register should be set according to the selected ADC sample rate. See “Clocking and Sample Rates” for details of the ADC sample rate.

In Hi-Fi mode, the high-pass filter is optimised for removing DC offsets without degrading the bass response and has a cut-off frequency of 3.5Hz when the sample rate (f_s) = 44.1kHz.

In Application mode, the HPF cut-off frequency is set using ADC_HPF_CUT. This mode is intended for voice communication; it is recommended to set the cut-off frequency below 300Hz (e.g. ADC_HPF_CUT = 101 when f_s = 8kHz or ADC_HPF_CUT = 101 when f_s = 16kHz).

REGISTER ADDRESS	BIT	LABEL	DEFAULT	DESCRIPTION
R5 (05h) ADC & DAC Control 1	0	ADC_HPF_DIS	0	ADC High-Pass Filter Disable 0 = Enable 1 = Disable
R6 (06h) ADC & DAC Control 2	13:12	ADC_HPF_SR [1:0]	10	ADC High-Pass Filter Sample rate 00 = 8k, 11.025k, 12k 01 = 16k, 22.025k, 24k 10 = 32k, 44.1, 48k 11 = 88.2k, 96k This field is for read-back only; it is set automatically and cannot be adjusted
	10	ADC_HPF_MODE	0	ADC High-Pass Filter Mode select 0 = Hi-Fi mode (1 st order) 1 = Application mode (2 nd order)
	9:7	ADC_HPF_CUT[2:0]	000	ADC High-Pass Filter Cutoff Note that the cut-off frequency scales with sample rate. See Table 32 for cut-off frequencies at all supported sample rates

Table 31 ADC High-Pass Filter

SAMPLE FREQUENCY (kHz)	CUT-OFF FREQUENCY (Hz)								
	HI-FI MODE	APPLICATION MODE / ADC_HPF_CUT[2:0]							
		000	001	010	011	100	101	110	111
8.000	3.0	80.5	100.5	129.0	160.5	200.5	256.5	320.5	400.5
11.025	4.5	111.0	138.5	177.5	221.0	276.5	353.0	442.0	551.5
12.000	4.5	120.5	151.0	193.0	240.5	300.5	384.5	481.0	600.5
16.000	3.0	80.0	101.0	129.0	161.0	200.5	256.5	321.0	401.0
22.050	4.5	110.5	139.0	177.5	221.5	276.0	353.5	442.0	552.5
24.000	4.5	120.5	151.5	193.5	241.5	300.5	385.0	481.5	601.0
32.000	2.5	80.0	101.5	129.0	160.5	200.0	257.5	320.0	401.0
44.100	3.5	110.0	139.5	177.5	221.0	275.5	355.0	441.0	552.5
48.000	4.0	119.5	152.0	193.0	240.5	300.0	386.5	480.0	601.0
88.200	3.5	112.5	139.0	177.0	220.0	274.0	355.0	442.0	551.0
96.000	4.0	122.5	151.5	192.5	239.5	298.0	386.5	481.0	600.0

Note: 'Hi-Fi Mode' refers to the mode when ADC_HPF_MODE = 0 (first order filtering and a cut-off frequency of 3.5Hz at a sample rate of 44.1kHz); 'Application Mode' refers to the mode when ADC_HPF_MODE = 1 (second order filtering and the cut-off frequency set by ADC_HPF_CUT)

Table 32 ADC High-Pass Filter Cut-Off Frequencies

The high-pass filter characteristics are shown in the "Digital Filter Characteristics" section.

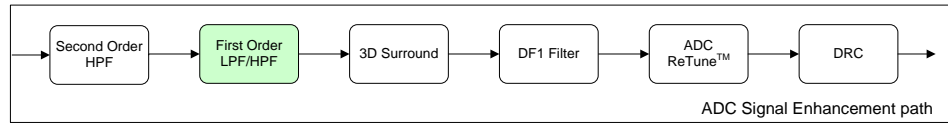
LOW-PASS / HIGH-PASS FILTER (LPF/HPF)

The Low-Pass / High-Pass filter is part of the ADC Signal Enhancement path.

This first-order filter can be configured to be high-pass or low-pass. It can be used to removed unwanted 'out of band' noise from the ADC signal path. The filter is enabled using the LHPF_ENA register bit defined in Table 33. The default setting is bypass (OFF). The High-Pass or Low-Pass configuration is selected using the LHPF_MODE register bit.

The filter can be programmed using the LHPF_COEFF register field (R265). For the derivation of this parameter, refer to the WISCE™ configuration tool supplied with the WM8962B Evaluation Kit.

REGISTER ADDRESS	BIT	LABEL	DEFAULT	DESCRIPTION
R264 (0108h) LHPF1	1	LHPF_MODE	0	Low/High-Pass Filter mode select 0 = Low-Pass 1 = High-Pass
	0	LHPF_ENA	0	Low/High-Pass Filter 0 = Disable 1 = Enable

Table 33 Low-Pass / High-Pass Filter Control

Example plots of the Low-pass / High-pass filter response are shown in Figure 24.

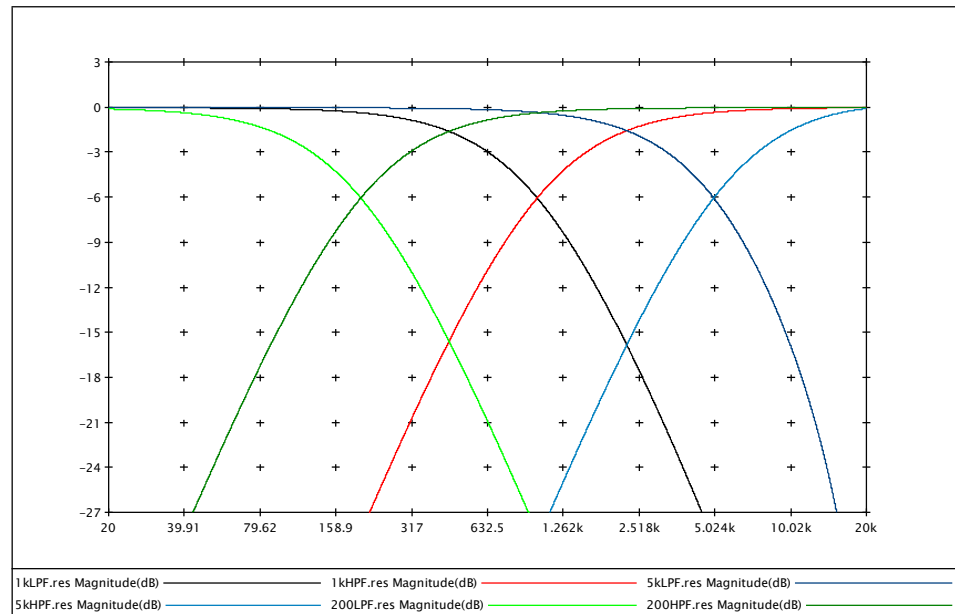
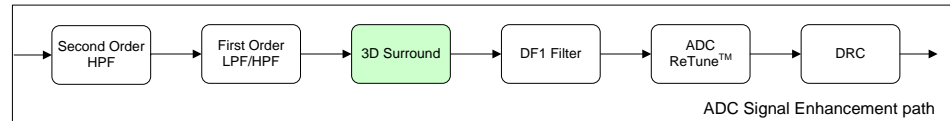

Figure 24 Low-pass / High-pass Filter Responses

3D SURROUND

The 3D Surround function is part of the ADC Signal Enhancement path.

The 3D Surround processing can be used in ADC record applications to select between a directional or wide-angle microphone response. Depending on the target application, the stereo widening capability could be selected manually, or else could be configured automatically for different operational modes, for example.

Note that the stereo widening is most effective at frequencies above 2kHz; lower frequencies may be attenuated by the phase cancellation process employed by the 3D Surround function. The DF1 filter (also part of the the ADC Signal Enhancement path) can be used to compensate for the attenuation of low frequencies; a low-shelf filter can be implemented in the DF1, as described later.

The 3D Surround effect is programmable; it uses time delays and controlled cross-talk mechanisms to adjust the depth or width of the stereo audio. The 3D Surround effect includes programmable high-pass or low-pass filtering to limit the effect to specific frequency bands if required. The structure of the 3D Surround processing is illustrated in Figure 25.

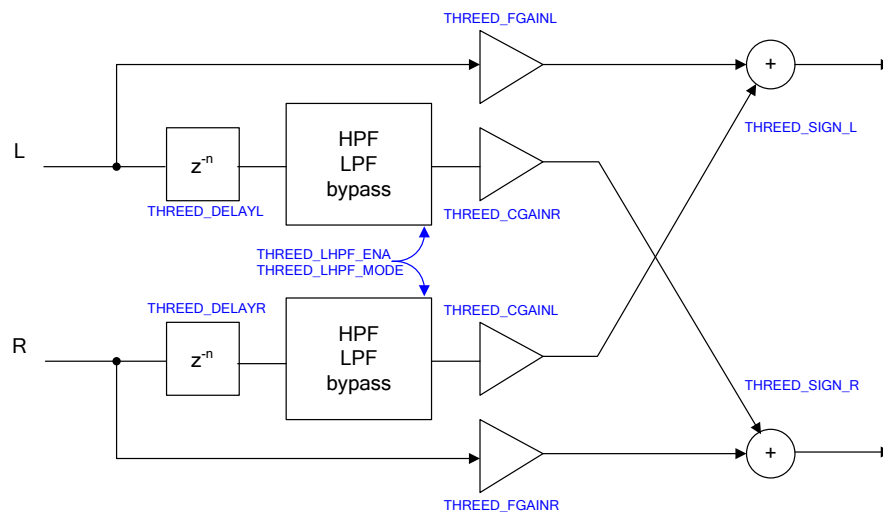

Figure 25 3D Surround Processing

The 3D Surround effect is enabled using the THREED_ENA register. Note that enabling 3D Surround will cause any ADC_MONOMIX settings to be ignored.

When 3D Surround is enabled, the left and right audio channels connect to the outputs using forward (same channel) paths and cross-feed (opposite channel) paths. The forward gain levels are determined by the THREED_FGAINL and THREED_FGAINR registers; the cross-feed gain levels are set by THREED_CGAINL (for right-to-left cross-feed) and THREED_CGAINR (for left-to-right cross-feed).

The polarity of the cross-feed mixing is controlled by the THREED_SIGN_L and THREED_SIGN_R register bits. If THREED_SIGN_L = 1 or THREED_SIGN_R = 1, then the respective cross-feed signal is subtracted from the main signal. If THREED_SIGN_L = 0 or THREED_SIGN_R = 0, then the respective cross-feed signal is added to the forward path signal.

A time delay can be applied to the cross-feed signals; this is selected using the THREED_DELAYL and THREED_DELAYR registers for the left and right channels respectively. The signals can be delayed up to a maximum of 8 samples.

High-Pass or Low-Pass filtering can be applied to the cross-feed signals. This is enabled by the THREED_LHPF_ENA register. The High-Pass or Low-Pass configuration is selected using the

THREED_LHPF_MODE register bit. This is typically used to filter out fixed-frequency noise or resonances.

The 3D Surround High-Pass / Low-Pass filter can be programmed using the THREED_LHPF_COEFF register field (R270). For the derivation of this parameter, refer to the WISCE™ configuration tool supplied with the WM8962B Evaluation Kit.

REGISTER ADDRESS	BIT	LABEL	DEFAULT	DESCRIPTION
R268 (010Ch) THREED1	5	THREED_SIGNL	0	3D Left Cross mixing polarity (from the right channel to the left) 0 = Positive 1 = Negative
	4	THREED_SIGNR	0	3D Right Cross mixing polarity (from the left channel to the right) 0 = Positive 1 = Negative
	2	THREED_LHPF_MODE	0	3D Low/High-Pass filter mode 0 = Low-Pass 1 = High-Pass
	1	THREED_LHPF_ENA	0	3D Low/High-Pass filter enable 0 = Disabled 1 = Enabled
	0	THREED_ENA	0	3D Surround Sound enable 0 = Disabled 1 = Enabled Note that setting THREED_ENA will cause any ADC_MONOMIX setting to be ignored
R269 (010Dh) THREED2	15:11	THREED_FGAIN L [4:0]	00000	3D Left Forward Gain 00000 = Mute 00001 = -11.25dB 00010 = -10.875dB (...in steps of -0.375dB) 11110 = -0.375dB 11111 = 0.0dB See Table 35 for a full list of gain settings
	10:6	THREED_CGAIN L [4:0]	00000	3D Left Cross Gain (from the right channel to the left) 00000 = Mute 00001 = -11.25dB 00010 = -10.875dB (...in steps of -0.375dB) 11110 = -0.375dB 11111 = 0.0dB See Table 35 for a full list of gain settings
	5:2	THREED_DELAY L [3:0]	0000	3D Left Filter Delay (measured from the sample rate) 0000 = 0 samples 0001 = 1 samples 0010 = 2 samples 0011 = 3 samples 0100 = 4 samples 0101 = 5 samples 0110 = 6 samples 0111 = 7 samples 1000 = 8 samples 1001 to 1111 = Reserved

REGISTER ADDRESS	BIT	LABEL	DEFAULT	DESCRIPTION
R271 (010Fh) THREED4	15:11	THREED_FGAIN R [4:0]	00000	3D Right Forward Gain 00000 = Mute 00001 = -11.25dB 00010 = -10.875dB (...in steps of -0.375dB) 11110 = -0.375dB 11111 = 0.0dB See Table 35 for a full list of gain settings
	10:6	THREED_CGAIN R [4:0]	00000	3D Right Cross Gain (from the left channel to the right) 00000 = Mute 00001 = -11.25dB 00010 = -10.875dB (...in steps of -0.375dB) 11110 = -0.375dB 11111 = 0.0dB See Table 35 for a full list of gain settings
	5:2	THREED_DELAY R [3:0]	0000	3D Filter Delay (measured from the sample rate) 0000 = 0 samples 0001 = 1 samples 0010 = 2 samples 0011 = 3 samples 0100 = 4 samples 0101 = 5 samples 0110 = 6 samples 0111 = 7 samples 1000 = 8 samples 1001 to 1111 = Reserved

Table 34 3D Surround Processing

THREED_FGAINL [4:0], THREED_CGAINL [4:0], THREED_FGAINR [4:0] OR THREED_CGAINR [4:0]	GAIN (dB)	THREED_FGAINL [4:0], THREED_CGAINL [4:0], THREED_FGAINR [4:0] OR THREED_CGAINR [4:0]	GAIN (dB)
0_0000	Mute	1_0000	-5.625
0_0001	-11.250	1_0001	-5.250
0_0010	-10.875	1_0010	-4.875
0_0011	-10.500	1_0011	-4.500
0_0100	-10.125	1_0100	-4.125
0_0101	-9.750	1_0101	-3.750
0_0110	-9.375	1_0110	-3.375
0_0111	-9.000	1_0111	-3.000
0_1000	-8.625	1_1000	-2.625
0_1001	-8.250	1_1001	-2.250
0_1010	-7.875	1_1010	-1.875
0_1011	-7.500	1_1011	-1.500
0_1100	-7.125	1_1100	-1.125
0_1101	-6.750	1_1101	-0.750
0_1110	-6.375	1_1110	-0.375
0_1111	-6.000	1_1111	0.000

Table 35 3D Surround Forward Gain and Cross Gain Range

DF1 FILTER

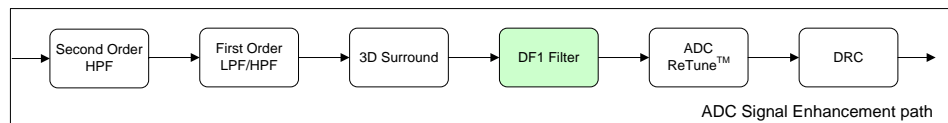

The DF1 Filter function is implemented in the ADC Signal Enhancement path.

The Direct-Form 1 (DF1) filter can be used to implement a wide variety of user-defined algorithms. Typical applications of this function include low-shelf, high-shelf or all-pass filters. (A low-shelf filter boosts or attenuates low frequencies; a high-shelf filter boosts or attenuates high frequencies. All-pass filters can be defined which pass all frequencies, but adjust the phase response of the signal.)

One of the recommended uses for the DF1 filter is as a low-shelf filter compensating for low frequency effects in the 3D Surround function. In this case, the DF1 filter should provide gain at low frequencies (eg. below 2kHz). An example low-shelf filter response is illustrated in Figure 26.

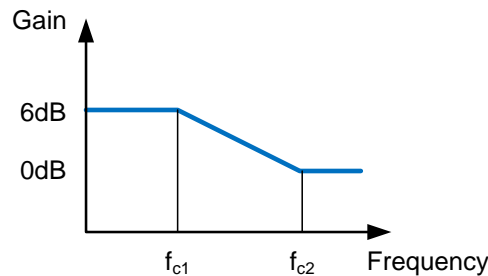

Figure 26 DF1 Low Shelf Filter Response

The Direct-Form 1 (DF1) standard filter is illustrated in Figure 27. All of the filter coefficients are programmable for the left and right channels independently, but DF1 can also be configured for both channels to share the filter coefficients from one or other of the channels. The default coefficients give a transparent filter response.

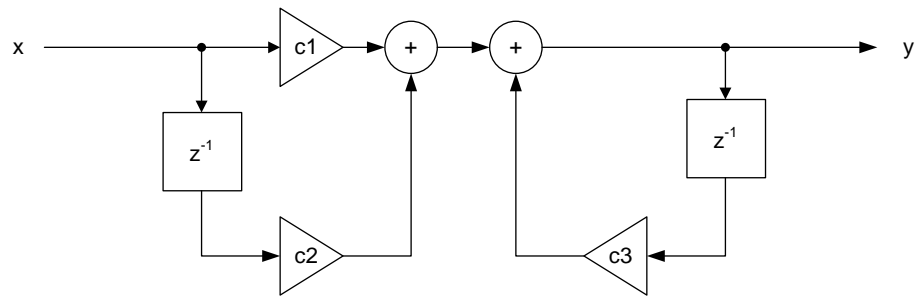

Figure 27 Direct-Form 1 Standard Filter Structure

The DF1 response is defined by the following equations:

$$y[n] = c_1x[n] + c_2x[n-1] + c_3y[n-1]$$

$$H = \frac{y}{x} = \frac{c_1 + c_2z^{-1}}{1 - c_3z^{-1}}$$

The DF1 filter is enabled on the ADC signal path using the DF1_ENA register bit defined in Table 36.

The DF1 filter can be configured for both channels to use the same filter coefficients; this is selected by setting the DF1_SHARED_COEFF register bit. When this bit is set, then the applicable coefficients are selected using DF1_SHARED_COEFF_SEL; it is possible to select either the left or right channel coefficients.

The DF1 filter can be used to implement very complex response patterns, with specific phase and gain responses at different frequencies. Typical applications of this type of filter include refinements or compensations to the 3D Surround, or other user-selected filters.

For the derivation of the DF1 Filter coefficients (registers R257 to R259 and for the left channel, R260 to R262 for the right channel), refer to the WISCE™ configuration tool supplied with the WM8962B Evaluation Kit.

REGISTER ADDRESS	BIT	LABEL	DEFAULT	DESCRIPTION
R256 (0100h) DF1	2	DF1_SHARED_COEFF	0	DF1 Shared Coefficients Enable 0 = Disabled 1 = Enabled
	1	DF1_SHARED_COEFF_SEL	0	DF1 Shared Coefficients Select 0 = Both channels use left coefficients 1 = Both channels use right coefficients
	0	DF1_ENA	0	DF1 Enable in ADC path 0 = Disabled 1 = Enabled

Table 36 Direct Form 1 (DF1) Filtering

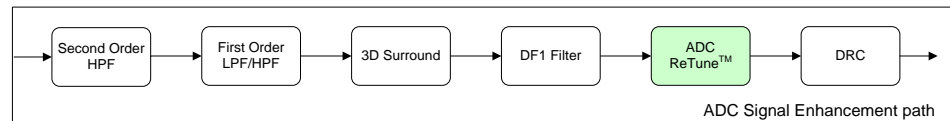
ADC RETUNE

The ReTune function is part of both the ADC and the DAC Signal Enhancement paths. It can be enabled on either path independently. Unique coefficient sets are supported for each path.

ReTune™ is an advanced feature that is intended to perform frequency linearisation according to the particular needs of the application microphone, loudspeaker or housing. The ReTune algorithms can provide acoustic equalisation and selective phase (delay) control of specific frequency bands. In a typical application, ReTune™ is used to flatten the response across the audio frequency band. ReTune™ can also be configured to achieve other response patterns if required.

Note that, when using ReTune™ to boost any frequency band, it is recommended to take care not to introduce distortion, taking into account the gain that may be applied by other audio enhancement functions.

Before ReTune™ is enabled, it must be initialised and configured using the DSP2_ENA bit described in Table 37. Note that this bit only needs to be enabled once before using any or all of ADC ReTune, DAC ReTune, DAC HPF, VSS or HD Bass.

Note that specific sequences must be followed when enabling or configuring ADC ReTune, DAC ReTune, DAC HPF, VSS, and HD Bass sound enhancement functions (see “Enable Sequence - Enhancements Initially Disabled”).

The ReTune function is enabled on the ADC path using the RTN_ADC_ENA register bit as described in Table 37. Under default conditions, the Left and Right channels each use unique tuning coefficients. When the ADC_RETUNE_SCV register is set, then both channels are controlled by the Right channel coefficients.

For the derivation of ADC ReTune configuration parameters in registers R17920 to R19007, the Cirrus WISCE™ software must be used to analyse the requirements of the application (refer to WISCE™ for further information.) If desired, one or more sets of register coefficients might be derived for different operating scenarios, and these may be recalled and written to the CODEC registers as required in the target application. The ADC ReTune configuration procedure involves the generation and analysis of test signals as outlined below. Note that DSP2_ENA must be enabled before there is any type of access of any of the parameters associated with ADC ReTune.

To determine the characteristics of the microphone in an application, a test signal is applied to a loudspeaker that is in the acoustic path to the microphone. The received signal through the application microphone is analysed and compared with the received signal from a reference microphone in order to determine the characteristics of the application microphone.

Note that the ReTune configuration coefficients are specific to a particular speaker or microphone; it is therefore required that the part-to-part variation in these components is small.

ADC ReTune is controlled using the register bits as described in Table 37.

REGISTER ADDRESS	BIT	LABEL	DEFAULT	DESCRIPTION
R768 (R300h) DSP2 Power Management	0	DSP2_ENA	0	DSP2 Audio Processor Enable. 0 = Disabled 1 = Enabled This bit must be set before any of ADC ReTune, DAC ReTune, DAC HPF, VSS or HD Bass is enabled. It must remain set whenever any of these functions is enabled.
R16384 (4000h) RETUNEADC_SHARED_COEFF_1	7	ADC_RETUNE_SCV	0	ADC ReTune Coefficient sharing 0 = Left and Right channels each use unique coefficients 1 = Both channels use the Right Channel coefficients
R16389 (4005h) SOUNDSTAGE_ENABLES_0	5	RTN_ADC_ENA	0	ADC ReTune enable 0 = disabled 1 = enabled

Table 37 ADC ReTune Enable

DYNAMIC RANGE CONTROL (DRC)

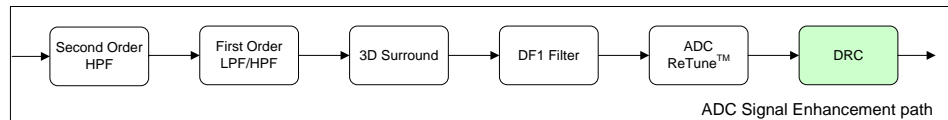

The dynamic range controller (DRC) is a circuit that can be enabled in either the digital record (ADC) or the digital playback (DAC) path of the WM8962B. Note that the DRC cannot be enabled in both signal paths at the same time.

The function of the DRC is to adjust the signal gain in conditions where the input amplitude is unknown or varies over a wide range, e.g. when recording from microphones built into a handheld system.

The DRC can apply Compression and Automatic Level Control to the signal path. It incorporates 'anti-clip' and 'quick release' features for handling transients in order to improve intelligibility in the presence of loud impulsive noises.

The DRC also incorporates a Noise Gate function, which provides additional attenuation of very low-level input signals. This means that the signal path is quiet when no signal is present, giving an improvement in background noise level under these conditions.

The DRC is enabled using DRC_ENA, as described in Table 38. The DRC is selected in the ADC signal path by setting DRC_MODE = 0.

REGISTER ADDRESS	BIT	LABEL	DEFAULT	DESCRIPTION
R276 (0114h) DRC 1	1	DRC_MODE	0	DRC path select 0 = ADC path 1 = DAC path
	0	DRC_ENA	0	DRC Enable 0 = Disabled 1 = Enabled

Table 38 DRC Mode and Enable

DRC COMPRESSION / EXPANSION / LIMITING

The DRC supports two different compression regions, separated by a “Knee” at a specific input amplitude. In the region above the knee, the compression slope DRC_HI_COMP applies; in the region below the knee, the compression slope DRC_LO_COMP applies.

The DRC also supports a noise gate region, where low-level input signals are heavily attenuated. This function can be enabled or disabled according to the application requirements. The DRC response in this region is defined by the expansion slope DRC_NG_EXP.

For additional attenuation of signals in the noise gate region, an additional “knee” can be defined (shown as “Knee2” in Figure 28). When this knee is enabled, this introduces an infinitely steep drop-off in the DRC response pattern between the DRC_LO_COMP and DRC_NG_EXP regions.

The overall DRC compression characteristic in “steady state” (i.e. where the input amplitude is near-constant) is illustrated in Figure 28.

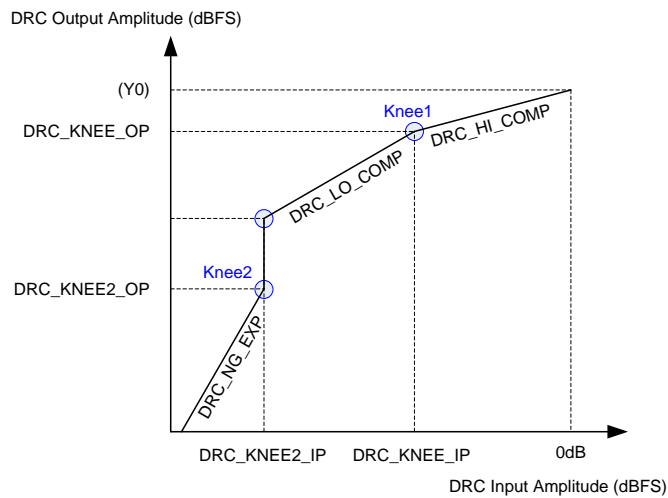

Figure 28 DRC Response Characteristic

The slope of the DRC response is determined by register fields DRC_HI_COMP and DRC_LO_COMP. A slope of 1 indicates constant gain in this region. A slope less than 1 represents compression (i.e. a change in input amplitude produces only a smaller change in output amplitude). A slope of 0 indicates that the target output amplitude is the same across a range of input amplitudes; this is infinite compression.

When the noise gate is enabled, the DRC response in this region is determined by the DRC_NG_EXP register. A slope of 1 indicates constant gain in this region. A slope greater than 1 represents expansion (i.e. a change in input amplitude produces a larger change in output amplitude).

When the DRC_KNEE2_OP knee is enabled (“Knee2” in Figure 28), this introduces the vertical line in the response pattern illustrated, resulting in infinitely steep attenuation at this point in the response.

The DRC parameters are listed in Table 39.

REF	PARAMETER	DESCRIPTION
1	DRC_KNEE_IP	Input level at Knee1 (dB)
2	DRC_KNEE_OP	Output level at Knee2 (dB)
3	DRC_HI_COMP	Compression ratio above Knee1
4	DRC_LO_COMP	Compression ratio below Knee1
5	DRC_KNEE2_IP	Input level at Knee2 (dB)
6	DRC_NG_EXP	Expansion ratio below Knee2
7	DRC_KNEE2_OP	Output level at Knee2 (dB)

Table 39 DRC Response Parameters

The noise gate is enabled when the DRC_NG_ENA register is set. When the noise gate is disabled, parameters 5, 6, and 7 above are ignored, and the DRC_LO_COMP slope applies to all input signal levels below Knee1.

The DRC_KNEE2_OP knee is enabled when the DRC_KNEE2_OP_ENA register is set. When this bit is not set, then parameter 7 above is ignored, and the Knee2 position always coincides with the low end of the DRC_LO_COMP region.

The “Knee1” point in Figure 28 is determined by register fields DRC_KNEE_IP and DRC_KNEE_OP.

Parameter Y0, the output level for a 0dB input, is not specified directly, but can be calculated from the other parameters, using the equation:

$$Y0 = DRC_KNEE_OP - (DRC_KNEE_IP \times DRC_HI_COMP)$$

The DRC Compression / Expansion / Limiting parameters are defined in Table 40.

REGISTER ADDRESS	BIT	LABEL	DEFAULT	DESCRIPTION
R276 (0114h) DRC1	7	DRC_NG_ENA	0	DRC Noise Gate Enable 0 = Disabled 1 = Enabled
	4	DRC_KNEE2_OP_ENA	0	DRC_KNEE2_OP Enable 0 = Disabled 1 = Enabled
R278 (0116h) DRC 3	7:6	DRC_NG_EXP [1:0]	00	Noise Gate slope 00 = 1 (no expansion) 01 = 2 10 = 4 11 = 8
	5:3	DRC_HI_COMP [2:0]	011	Compressor slope (upper region) 000 = 1 (no compression) 001 = 1/2 010 = 1/4 011 = 1/8 (default) 100 = 1/16 101 = 0 (ALC Mode) 110 = Reserved 111 = Reserved
	2:0	DRC_LO_COMP [2:0]	000	Compressor slope (lower region) 000 = 1 (no compression) 001 = 1/2 010 = 1/4 011 = 1/8 100 = 0 101 to 111 = Reserved

REGISTER ADDRESS	BIT	LABEL	DEFAULT	DESCRIPTION
R279 (0117h) DRC 4	10:5	DRC_KNEE_IP [5:0]	000000	Input signal level at the Compressor 'Knee'. 000000 = 0dB 000001 = -0.75dB 000010 = -1.5dB ... (-0.75dB steps) 111100 = -45dB 111101 to 111111 = Reserved
	4:0	DRC_KNEE_OP [4:0]	00000	Output signal at the Compressor 'Knee'. 00000 = 0dB 00001 = -0.75dB 00010 = -1.5dB ... (-0.75dB steps) 11110 = -22.5dB 11111 = Reserved
R280 (0117h) DRC 4	9:5	DRC_KNEE2_IP [4:0]	00000	Input signal level at the Noise Gate threshold 'Knee2'. 00000 = -36dB 00001 = -37.5dB 00010 = -39dB ... (-1.5dB steps) 11110 = -81dB 11111 = -82.5dB Only applicable when DRC_NG_ENA = 1.
	4:0	DRC_KNEE2_OP [4:0]	00000	Output signal at the Noise Gate threshold 'Knee2'. 00000 = -30dB 00001 = -31.5dB 00010 = -33dB ... (-1.5dB steps) 11110 = -75dB 11111 = -76.5dB Only applicable when DRC_KNEE2_OP_ENA = 1.

Table 40 DRC Control Registers

DRC GAIN LIMITS

The minimum and maximum gain applied by the DRC is set by register fields DRC_MINGAIN, DRC_MAXGAIN and DRC_NG_MINGAIN. These limits can be used to alter the DRC response from that illustrated in Figure 28. If the range between maximum and minimum gain is reduced, then the extent of the dynamic range control is reduced.

The minimum gain in the Compression regions of the DRC response is set by DRC_MINGAIN. The minimum gain in the Noise Gate region is set by DRC_NG_MINGAIN. The minimum gain limit prevents excessive attenuation of the signal path.

The maximum gain limit set by DRC_MAXGAIN prevents quiet signals (or silence) from being excessively amplified.

REGISTER ADDRESS	BIT	LABEL	DEFAULT	DESCRIPTION
R277 (0115h) DRC 2	4:2	DRC_MINGAIN [2:0]	001	Minimum gain the DRC can use to attenuate audio signals 000 = 0dB 001 = -12dB (default) 010 = -18dB 011 = -24dB 100 = -36dB 101to 111 = Reserved
	1:0	DRC_MAXGAIN [1:0]	01	Maximum gain the DRC can use to boost audio signals (dB) 00 = 12dB 01 = 18dB (default) 10 = 24dB 11 = 36dB
R278 (0116h) DRC 3	15:12	DRC_NG_MINGAIN [3:0]	0000	Minimum gain the DRC can use to attenuate audio signals when the noise gate is active. 0000 = -36dB 0001 = -30dB 0010 = -24dB 0011 = -18dB 0100 = -12dB 0101 = -6dB 0110 = 0dB 0111 = 6dB 1000 = 12dB 1001 = 18dB 1010 = 24dB 1011 = 30dB 1100 to 1111 = Reserved

Table 41 DRC Gain Limits

DRC DYNAMIC CHARACTERISTICS

The dynamic behaviour determines how quickly the DRC responds to changing signal levels. Note that the DRC responds to the average (RMS) signal amplitude over a period of time.

The DRC_ATK determines how quickly the DRC gain decreases when the signal amplitude is high. The DRC_DCY determines how quickly the DRC gain increases when the signal amplitude is low.

These register fields are described in Table 16. Note that the register defaults are suitable for general purpose microphone use.

REGISTER ADDRESS	BIT	LABEL	DEFAULT	DESCRIPTION
R277 (0115h) DRC Control 2	12:9	DRC_ATK [3:0]	0100	Gain attack rate (seconds/6dB) 0000 = Reserved 0001 = 181us 0010 = 363us 0011 = 726us 0100 = 1.45ms 0101 = 2.9ms 0110 = 5.8ms 0111 = 11.6ms 1000 = 23.2ms 1001 = 46.4ms 1010 = 92.8ms 1011 = 185.6ms 1100-1111 = Reserved
	8:5	DRC_DCY [3:0]	1001	Gain decay rate (seconds/6dB) 0000 = 1.45ms 0001 = 2.9ms 0010 = 5.8ms 0011 = 11.6ms 0100 = 23.25ms 0101 = 46.5ms 0110 = 93ms 0111 = 186ms 1000 = 372ms 1001 = 743ms (default) 1010 = 1.49s 1011 = 2.97s 1100 = 5.94s 1101 = 11.89s 1110 = 23.78s 1111 = 47.56s

Table 42 DRC Time Constants

DRC ANTI-CLIP CONTROL

The DRC includes an Anti-Clip feature to avoid signal clipping when the input amplitude rises very quickly. This feature uses a feed-forward technique for early detection of a rising signal level. Signal clipping is avoided by dynamically increasing the gain attack rate when required. The Anti-Clip feature is enabled using the DRC_ANTICLIP bit.

Note that the feed-forward processing increases the latency in the input signal path. The DRC Anti-Clip control is described in Table 43.

REGISTER ADDRESS	BIT	LABEL	DEFAULT	DESCRIPTION
R276 (0114h) DRC Control 1	2	DRC_ANTICLIP	1	DRC Anti-clip Enable 0 = Disabled 1 = Enabled

Table 43 DRC Anti-Clip Control

Note that the Anti-Clip feature operates entirely in the digital domain. It cannot be used to prevent signal clipping in the analogue domain nor in the source signal. Analogue clipping can only be prevented by reducing the analogue signal gain or by adjusting the source signal.

DRC QUICK-RELEASE CONTROL

The DRC includes a Quick-Release feature to handle short transient peaks that are not related to the intended source signal. For example, in handheld microphone recording, transient signal peaks sometimes occur due to user handling, key presses or accidental tapping against the microphone. The Quick Release feature ensures that these transients do not cause the intended signal to be masked by the longer time constants of DRC_DCY.

The Quick-Release feature is enabled by setting the DRC_QR bit. When this bit is enabled, the DRC measures the crest factor (peak to RMS ratio) of the input signal. A high crest factor is indicative of a transient peak that may not be related to the intended source signal. If the crest factor exceeds the level set by DRC_QR_THR, then the normal decay rate (DRC_DCY) is ignored and a faster decay rate (DRC_QR_DCY) is used instead.

The DRC Quick-Release control bits are described in Table 44.

REGISTER ADDRESS	BIT	LABEL	DEFAULT	DESCRIPTION
R276 (0114h) DRC 1	3	DRC_QR	1	DRC Quick-release Enable 0 = Disabled 1 = Enabled
R278 (0116h) DRC 3	11:10	DRC_QR_THR [1:0]	00	DRC Quick-release threshold (crest factor in dB) 00 = 12dB 01 = 18dB 10 = 24dB 11 = 30dB
	9:8	DRC_QR_DCY [1:0]	00	DRC Quick-release decay rate (seconds/6dB) 00 = 0.725ms 01 = 1.45ms 10 = 5.8ms 11 = reserved

Table 44 DRC Quick-Release Control

DRC SIGNAL ACTIVITY DETECT

The DRC incorporates a configurable signal detect function, allowing the signal level at the DRC input to be monitored and to be used to trigger other events. This can be used to detect the presence of a microphone signal on an ADC channel, or can be used to detect an audio signal received over the digital audio interface.

The Peak signal level or the RMS signal level of the DRC input can be selected as the detection threshold. When the threshold condition is exceeded, an interrupt or GPIO output can be generated. See “General Purpose Input/Output (GPIO)” and “Interrupts” for further details.

When the DRC is enabled, then signal activity detection can be enabled by setting the DRC_SIG_DET register bit. The applicable threshold can be defined either as a Peak level (Crest Factor) or an RMS level, depending on the DRC_SIG_DET_MODE register bit. When Peak level is selected, the threshold is determined by DRC_SIG_DET_PK, which defines the applicable Crest Factor (Peak to RMS ratio) threshold. If RMS level is selected, then the threshold is set using DRC_SIG_DET_RMS. These register fields are described in Table 45.

REGISTER ADDRESS	BIT	LABEL	DEFAULT	DESCRIPTION
R276 (0114h) DRC1	14:10	DRC_SIG_DET_RMS [4:0]	00000	DRC Signal Detect RMS Threshold. This is the RMS signal level for signal detect to be indicated when DRC_SIG_DET_MODE=1. 00000 = -27dB 00001 = -28.5dB (1.5dB steps) 11110 = -72dB 11111 = -73.5dB
	9:8	DRC_SIG_DET_PK [1:0]	00	DRC Signal Detect Peak Threshold. This is the Peak/RMS ratio, or Crest Factor, level for signal detect to be indicated when DRC_SIG_DET_MODE=0. 00 = 14dB 01 = 20dB 10 = 26dB 11 = 32dB
	6	DRC_SIG_DET_MODE	0	DRC Signal Detect Mode 0 = Peak threshold mode 1 = RMS threshold mode
	5	DRC_SIG_DET	0	DRC Signal Detect Enable 0 = Disabled 1 = Enabled

Table 45 DRC Signal Activity Detect GPIO/Interrupt Control

DIGITAL MIXING

The ADC and DAC data can be combined in various ways to support a range of different usage modes.

Under default conditions, data from the Left and Right ADCs is routed to the Left and Right channels respectively of the digital audio interface. The channels can be swapped if required and digital inversion of either signal is also possible. See “Digital Audio Interface” for more information on the audio interface.

By default, the Left and Right input channels of the digital audio interface are routed to the Left and Right DACs respectively on the WM8962B. The channels can be swapped if required and digital inversion of either signal is also possible.

A mono mix of the two audio channels into a single DAC can be selected, as described in the “Digital-to-Analogue Converter (DAC)” section.

Digital sidetone from the ADCs can also be selectively mixed into the DAC output path, as described later in this section.

DIGITAL MIXING PATHS

Figure 29 shows the digital mixing paths available in the WM8962B digital core.

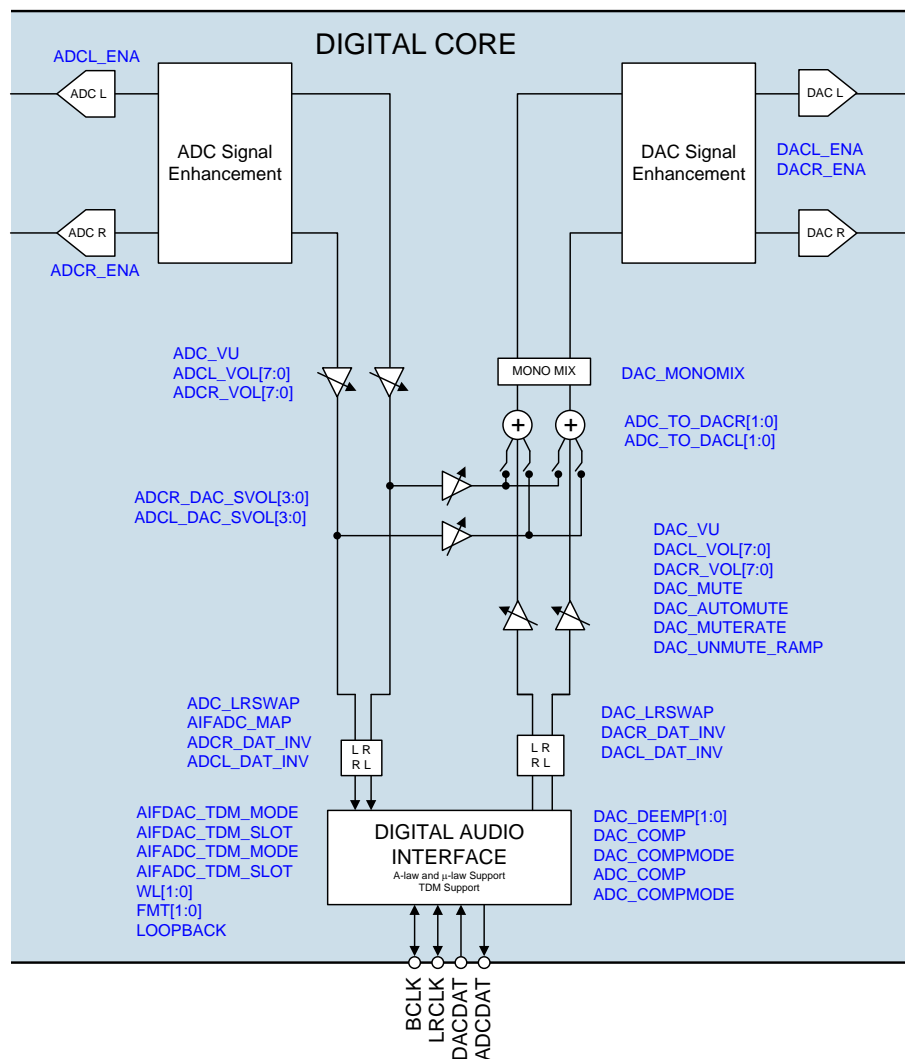

Figure 29 Digital Mixing Paths

The polarity of each ADC output signal can be changed under software control using the ADCR_DAT_INV and ADCL_DAT_INV register bits. The ADC_LRSWAP register bit may be used to swap the left and right digital audio interface data. These register bits are described in Table 46.

REGISTER ADDRESS	BIT	LABEL	DEFAULT	DESCRIPTION
R5 (05h) ADC & DAC Control 1	6	ADCR_DAT_INV	0	Right ADC Invert 0 = Right ADC output not inverted 1 = Right ADC output inverted
	5	ADCL_DAT_INV	0	Left ADC Invert 0 = Left ADC output not inverted 1 = Left ADC output inverted
R7 (07h) Audio Interface 0	8	ADC_LRSWAP	0	Swap left/right ADC data on the interface 0 = Normal 1 = ADCDAT channels swapped

Table 46 ADC Routing and Control

The input data source for each DAC can be controlled using the DAC_LRSWAP register bit; this swaps the left and right channel input data within the digital audio interface. The polarity of each DAC input may also be modified using register bits DACR_DAT_INV and DACL_DAT_INV. These register bits are described in Table 47.

REGISTER ADDRESS	BIT	LABEL	DEFAULT	DESCRIPTION
R6 (06h) ADC & DAC Control 2	6	DACR_DAT_INV	0	Right DAC Invert 0 = Right DAC input not inverted 1 = Right DAC input inverted
	5	DACL_DAT_INV	0	Left DAC Invert 0 = Left DAC input not inverted 1 = Left DAC input inverted
R7 (07h) Audio Interface 0	5	DAC_LRSWAP	0	Swap left/right DAC data on the interface 0 = Normal 1 = DACDAT channels swapped

Table 47 DAC Routing and Control

DIGITAL SIDETONE

Digital sidetone mixing (from ADC output into DAC input) is available. Digital data from either left or right ADC can be mixed with the audio interface data on the left and right DAC channels. Sidetone data is taken from the ADC high-pass filter output, to reduce low frequency noise in the sidetone (e.g. wind noise or mechanical vibration).

When using the digital sidetone, it is recommended that the ADCs are enabled before un-muting the DACs to prevent pop noise. The DAC volumes and sidetone volumes should be set to an appropriate level to avoid clipping at the DAC input.

When digital sidetone is used, it is recommended that the Charge Pump operates in Register Control mode only (CP_DYN_PWR = 0). If Dynamic Control mode (CP_DYN_PWR = 1) is used, the headphone output may be clipped. See "Charge Pump" for details.

The digital sidetone is controlled as shown in Table 48.

REGISTER ADDRESS	BIT	LABEL	DEFAULT	DESCRIPTION
R57 (39h) DAC DSP Mixing (1)	7:4	ADCR_DAC_SV OL [3:0]	0000	Right ADC Digital Sidetone Volume 0000 = -36dB 0001 = -33dB (... 3dB steps) 1011 = -3dB 11XX = 0dB (See Table 49 for volume range)
	3:2	ADC_TO_DACR [1:0]	00	Right DAC Digital Sidetone Source 00 = No sidetone 01 = Left ADC 10 = Right ADC 11 = No sidetone
R58 (3Ah) DAC DSP Mixing (2)	7:4	ADCL_DAC_SV OL [3:0]	0000	Left ADC Digital Sidetone Volume 0000 = -36dB 0001 = -33dB (... 3dB steps) 1011 = -3dB 11XX = 0dB (See Table 49 for volume range)
	3:2	ADC_TO_DACL [1:0]	00	Left DAC Digital Sidetone Source 00 = No sidetone 01 = Left ADC 10 = Right ADC 11 = No sidetone

Table 48 Digital Sidetone Control

The digital sidetone volume settings are shown in Table 49.

ADCR_DAC_SVOL OR ADCL_DAC_SVOL	SIDETONE VOLUME
0000	-36
0001	-33
0010	-30
0011	-27
0100	-24
0101	-21
0110	-18
0111	-15
1000	-12
1001	-9
1010	-6
1011	-3
1100	0
1101	0
1110	0
1111	0

Table 49 Digital Sidetone Volume

T-LOOPBACK

The T-Loopback function provides a specialised mode for use in communications applications such as VOIP handset configurations. The T-Loopback configuration provides a mono ADC and mono DAC signal to be output via the Digital Audio Interface transmit path. This allows Acoustic Echo Cancellation to be performed using difference algorithms implemented on an external processor.

T-Loopback is enabled by setting the TLB_ENA register bit, as described in Table 51.

When T-Loopback is enabled, the Digital Audio Interface outputs are configured according to the TLB_MODE bit, as described below.

DESCRIPTION	LEFT AIF OUTPUT	RIGHT AIF OUTPUT
TLB_MODE = 0	Left ADC	(Left DAC + Right DAC)/2
TLB_MODE = 1	(Left DAC + Right DAC)/2	Right ADC

Table 50 T-Loopback Mode Select

Note that the Left ADC and Right ADC signals can be digitally mixed, if required. This enables the sum of the Left and Right ADC channels to be output in T-Loopback. The ADC Monomix feature is described in the “ADC Monomix” section.

Note that the Left DAC and Right DAC signals used in the T-Loopback are also controlled by the DAC Digital Volume controls (see “Digital-to-Analogue Converter (DAC)”). It is possible to output just a single DAC channel in T-Loopback mode by setting the Digital Volume to zero in the unwanted channel.

The register bits associated with T-Loopback are described in Table 51.

REGISTER ADDRESS	BIT	LABEL	DEFAULT	DESCRIPTION
R285 (011Dh) Tloopback	1	TLB_ENA	0	T-Loopback Enable 0 = Disabled 1 = Enabled
	0	TLB_MODE	0	T-Loopback Mode Select 0: Left AIF Output = Left ADC; Right AIF Output = (Left DAC + Right DAC) / 2 1: Left AIF Output = (Left DAC + Right DAC) / 2; Right AIF Output = Right ADC

Table 51 T-Loopback Control

The signal paths when T-Loopback is enabled (TLB_ENA = 1) are illustrated in Figure 30.

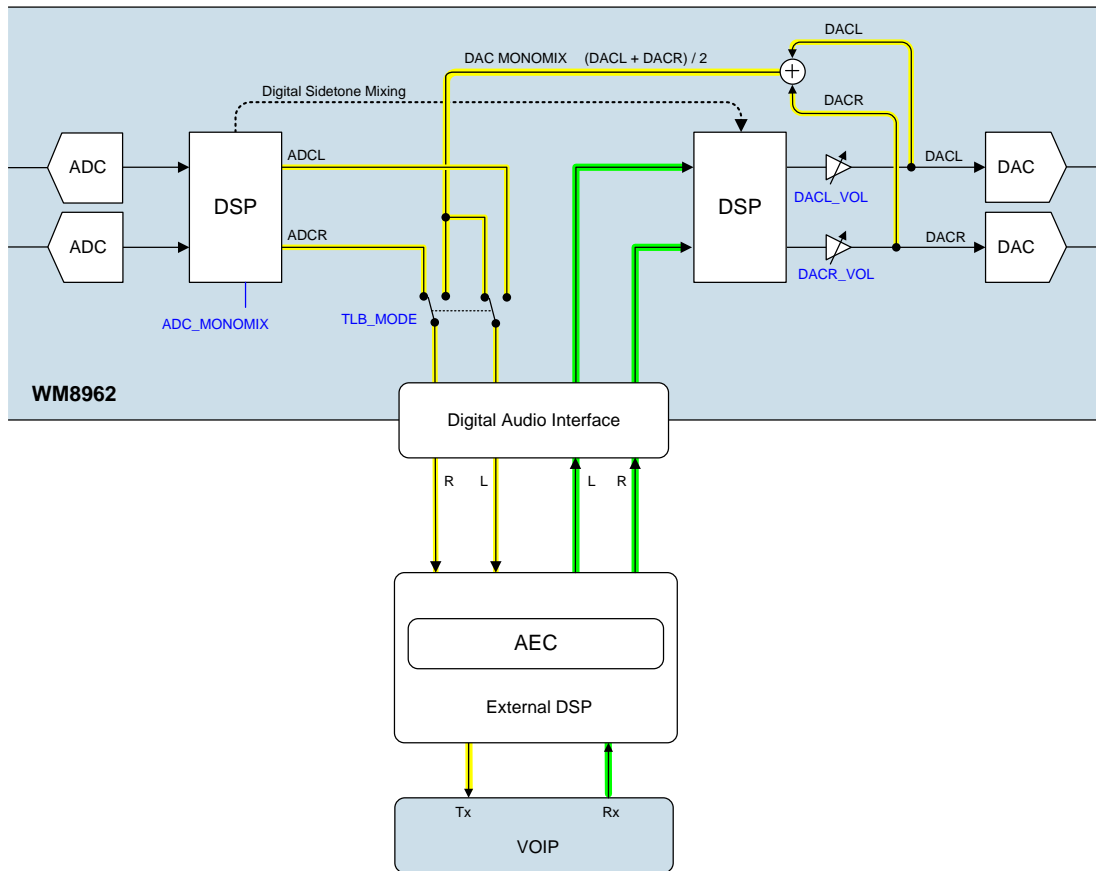

Figure 30 T-Loopback Signal Paths

DAC SIGNAL PATH ENHANCEMENTS

The DAC signal path incorporates a number of sound enhancement features, as illustrated in Figure 31. These features are described more fully in the following sections.

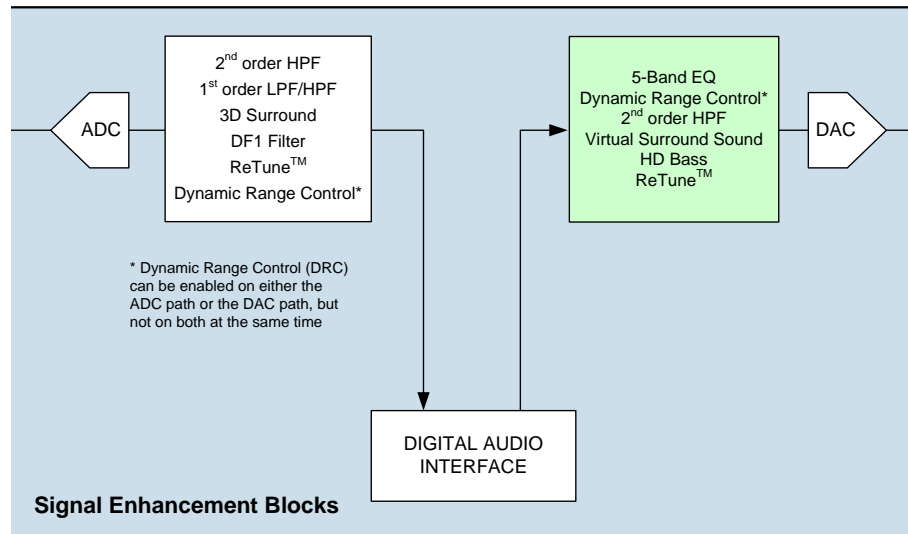
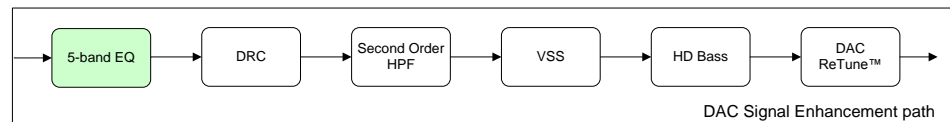

Figure 31 DAC Signal Enhancements

5-BAND EQ



The 5-band EQ function is implemented in the DAC Signal Enhancement path.

The 5-band EQ can be used to support user preferences for different music types, such as allowing selection of 'rock', 'dance', 'classical' or other user-defined EQ profiles. The 5-band EQ can also be used to provide compensation for imperfect characteristics of other components in the audio chain, such as the loudspeaker in portable applications in particular.

Note that the functionality of the 5-band EQ has similarities to some of the other DAC signal enhancements; it is important to select the most appropriate processing block for each requirement. The 5-band EQ provides a basic level of signal control, whilst the other enhancements can provide superior performance in many cases.

Frequency compensation of loudspeakers and other components can be implemented using the DAC ReTune function, which provides a more powerful capability to normalise the frequency response; this is achieved through the use of calibrated measurement procedures. The 5-band EQ provides a simpler and coarser type of signal control.

Reduction of bass frequencies (removing signal content that the speaker is unable to reproduce) can be implemented using the 2nd order High Pass Filter (DAC HPF); this provides greater attenuation of the bass frequencies, without affecting the desired pass-band.

Enhancement of bass frequencies (compensation for poor sensitivity in headphones or loudspeakers at low frequencies) can be implemented using the HD Bass function; this is a more intelligent and adaptive audio enhancement than the 5-band EQ.

Note that, when using the 5-band EQ to boost any frequency band, it is recommended to take care not to introduce distortion, taking into account the gain that may be applied by other audio enhancement functions.

The 5-band EQ allows the gain within five frequency bands to be controlled. The upper and lower frequency bands are controlled by low-pass and high-pass filters respectively. The middle three frequency bands are notch filters.

The 5-band EQ is enabled by setting the EQ_ENA register as described in Table 53.

In default mode, the cut-off / centre frequencies are fixed as described in Table 52. The filter bandwidths are also fixed in this mode. The gain of the individual bands (-12dB to +12dB) can be controlled as described in Table 54.

The cut-off / centre frequencies noted in Table 52 are applicable to a sample rate of 48kHz. Note that, when using other sample rates, these frequencies will be scaled in proportion to the selected sample rate (see “Clocking and Sample Rates”).

EQ BAND	CUT-OFF/CENTRE FREQUENCY
1	100 Hz
2	300 Hz
3	875 Hz
4	2400 Hz
5	6900 Hz

Table 52 EQ Band Cut-off / Centre Frequencies

The gain for each of the five EQ bands on each of the channels is individually programmable using the register bits described in Table 53. The gain in each band on each channel is controllable in 1dB steps from -12dB to +12dB.

The 5-band EQ can be configured for both channels to use the same configuration settings; this is selected by setting the EQ_SHARED_COEFF register bit. When this bit is set, then the applicable coefficients are selected using EQ_SHARED_COEFF_SEL; it is possible to select either the left or right channel coefficients.

It is also possible for the user to define the cut-off/centre frequencies and the filter bandwidth for each EQ band, in addition to the gain controls already defined. This enables the EQ to be accurately customised for a specific transducer characteristic or desired sound profile.

For the derivation of the 5-Band EQ configuration parameters in registers R338 to R355 (Left channel) and R358 to R375 (Right channel), refer to the WISCE™ configuration tool supplied with the WM8962B Evaluation Kit.

REGISTER ADDRESS	BIT	LABEL	DEFAULT	DESCRIPTION
R335 (014Fh) EQ1	2	EQ_SHARED_COEFF	1	5-Band EQ Shared Coefficient enable 0 = Right and Left channels use unique coefficients 1 = Left and right channels share filter coefficients
	1	EQ_SHARED_COEFF_SEL	0	5-Band EQ Shared Coefficient select 0 = Both channels use the left channel filter coefficients 1 = Both channels use the right channel filter coefficients
	0	EQ_ENA	0	5-Band EQ Enable 0 = Disabled 1 = Enabled
R336 (0150h) EQ2	15:11	EQL_B1_GAIN[4:0]	01100	Left Channel Band 1 EQ Gain 0_0000 = -12dB 0_0001 = -11dB ...1dB steps to 1_1000 = +12dB 1_1001 to 1_1111 reserved See Table 54 for the full range
	10:6	EQL_B2_GAIN[4:0]	01100	Left Channel Band 2 EQ Gain 0_0000 = -12dB 0_0001 = -11dB ...1dB steps to 1_1000 = +12dB 1_1001 to 1_1111 reserved See Table 54 for the full range

REGISTER ADDRESS	BIT	LABEL	DEFAULT	DESCRIPTION
	5:1	EQL_B3_GAIN[4:0]	01100	Left Channel Band 3 EQ Gain 0_0000 = -12dB 0_0001 = -11dB ...1dB steps to 1_1000 = +12dB 1_1001 to 1_1111 reserved See Table 54 for the full range
R337 (0151h) EQ2	15:11	EQL_B4_GAIN[4:0]	01100	Left Channel Band 4 EQ Gain 0_0000 = -12dB 0_0001 = -11dB ...1dB steps to 1_1000 = +12dB 1_1001 to 1_1111 reserved See Table 54 for the full range
	10:6	EQL_B5_GAIN[4:0]	01100	Left Channel Band 5 EQ Gain 0_0000 = -12dB 0_0001 = -11dB ...1dB steps to 1_1000 = +12dB 1_1001 to 1_1111 reserved See Table 54 for the full range
R356 (0164h) EQ2	15:11	EQR_B1_GAIN[4:0]	01100	Right Channel Band 1 EQ Gain 0_0000 = -12dB 0_0001 = -11dB ...1dB steps to 1_1000 = +12dB 1_1001 to 1_1111 reserved See Table 54 for the full range
	10:6	EQR_B2_GAIN[4:0]	01100	Right Channel Band 2 EQ Gain 0_0000 = -12dB 0_0001 = -11dB ...1dB steps to 1_1000 = +12dB 1_1001 to 1_1111 reserved See Table 54 for the full range
	5:1	EQR_B3_GAIN[4:0]	01100	Right Channel Band 3 EQ Gain 0_0000 = -12dB 0_0001 = -11dB ...1dB steps to 1_1000 = +12dB 1_1001 to 1_1111 reserved See Table 54 for the full range
R357 (0165h) EQ2	15:11	EQR_B4_GAIN[4:0]	01100	Right Channel Band 4 EQ Gain 0_0000 = -12dB 0_0001 = -11dB ...1dB steps to 1_1000 = +12dB 1_1001 to 1_1111 reserved See Table 54 for the full range
	10:6	EQR_B5_GAIN[4:0]	01100	Right Channel Band 5 EQ Gain 0_0000 = -12dB 0_0001 = -11dB ...1dB steps to 1_1000 = +12dB 1_1001 to 1_1111 reserved See Table 54 for the full range

Table 53 5-Band EQ Control

5-BAND EQ GAIN	GAIN (dB)	5-BAND EQ GAIN	GAIN (dB)
0_0000	-12	0_1101	+1
0_0001	-11	0_1110	+2
0_0010	-10	0_1111	+3
0_0011	-9	1_0000	+4
0_0100	-8	1_0001	+5
0_0101	-7	1_0010	+6
0_0110	-6	1_0011	+7
0_0111	-5	1_0100	+8
0_1000	-4	1_0101	+9
0_1001	-3	1_0110	+10
0_1010	-2	1_0111	+11
0_1011	-1	1_1000	+12
0_1100	0	1_1001 to 1_1111	Reserved

Table 54 5-Band EQ Gain Range

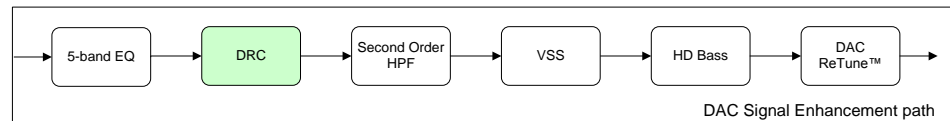
DYNAMIC RANGE CONTROL (DRC)

The dynamic range controller (DRC) is a circuit that can be enabled in either the digital record (ADC) or the digital playback (DAC) path of the WM8962B. Note that the DRC cannot be enabled in both signal paths at the same time.

The function of the DRC is to adjust the signal gain in conditions where the input amplitude is unknown or varies over a wide range, e.g. when recording from microphones built into a handheld system.

The DRC can apply Compression and Automatic Level Control to the signal path. It incorporates 'anti-clip' and 'quick release' features for handling transients in order to improve intelligibility in the presence of loud impulsive noises.

The DRC also incorporates a Noise Gate function, which provides additional attenuation of very low-level input signals. This means that the signal path is quiet when no signal is present, giving an improvement in background noise level under these conditions.

The DRC is enabled using DRC_ENA, as described in Table 55. The DRC is selected in the DAC signal path by setting DRC_MODE = 1.

Additional registers for configuring the DRC are described in the "ADC Signal Path Enhancements" section.

REGISTER ADDRESS	BIT	LABEL	DEFAULT	DESCRIPTION
R276 (0114h) DRC 1	1	DRC_MODE	0	DRC path select 0 = ADC path 1 = DAC path
	0	DRC_ENA	0	DRC Enable 0 = Disabled 1 = Enabled

Table 55 DRC Mode and Enable

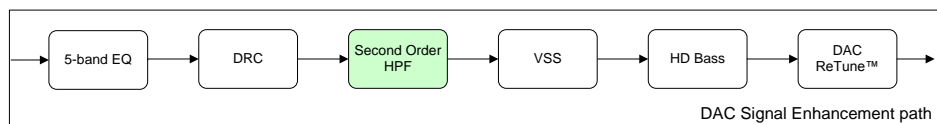
DAC SECOND ORDER HIGH-PASS FILTER

The 2nd order High-Pass Filter (HPF) is part of the DAC Signal Enhancement path.

The DAC High-Pass filter is provided to remove DC offsets and low frequencies from the DAC signal path. This is an important function as DC offsets in the audio signal will reduce the signal headroom and increase power consumption. DC offsets and low frequency signals that are outside the capabilities of the loudspeaker will result in audible distortion and can cause damage to speakers or headphones.

The cut-off frequency of the DAC High-Pass filter should be set to attenuate the frequencies that the speaker cannot reproduce, but without unnecessarily removing higher frequencies that can be supported. The 2nd order cut-off slope of 12dB per octave provides good selectivity between the frequencies to be cut and the frequencies to be retained.

The DAC High-Pass filter is particularly recommended for use with the VSS, HD Bass and DAC ReTune functions in order to prevent distortion and speaker damage.

Before the DAC High-Pass filter is enabled, it must be initialised and configured using the DSP2_ENA bit described in Table 56. Note that this bit only needs to be enabled once before using any or all of ADC ReTune, DAC ReTune, DAC HPF, VSS or HD Bass.

Note that specific sequences must be followed when enabling or configuring ADC ReTune, DAC ReTune, DAC HPF, VSS, and HD Bass sound enhancement functions (see “Enable Sequence - Enhancements Initially Disabled”).

The 2nd order High Pass Filter comprises two 1st order filters, which are enabled using the HPF1_ENA and HPF2_ENA register bits as described in Table 56. Either one of the filters, or both filters, may be enabled. Each filter provides a cut-off slope of 6dB per octave; when both filters are enabled together, the combined effect is a second-order filter, with a cut-off slope of 12dB per octave.

Note that the DAC high pass filters cannot be enabled unless one or more other sound enhancement functions is enabled. If HPF1_ENA = 1 or HPF2_ENA = 1, then at least one other of the enable bits in Register R16389 must also be set (ie. RTN_ADC_ENA, RTN_DAC_ENA, HDBASS_ENA or VSS_ENA).

For the derivation of the High-Pass Filter configuration parameters in registers R17408 and R17409, refer to the WISCE™ configuration tool supplied with the WM8962B Evaluation Kit. Note that both filters (HPF1 and HPF2) use the same configuration parameters.

REGISTER ADDRESS	BIT	LABEL	DEFAULT	DESCRIPTION
R768 (R300h) DSP2 Power Management	0	DSP2_ENA	0	DSP2 Audio Processor Enable. 0 = Disabled 1 = Enabled This bit must be set before any of ADC ReTune, DAC ReTune, DAC HPF, VSS or HD Bass is enabled. It must remain set whenever any of these functions is enabled.
R16389 (4005h) SOUNDSTAGE _ENABLES_0	2	HPF2_ENA	0	High-Pass Filter (HPF2) enable 0 = Disabled 1 = Enabled
	1	HPF1_ENA	0	High Pass Filter (HPF1) enable 0 = Disabled 1 = Enabled

Table 56 DAC High Pass Filter Enable

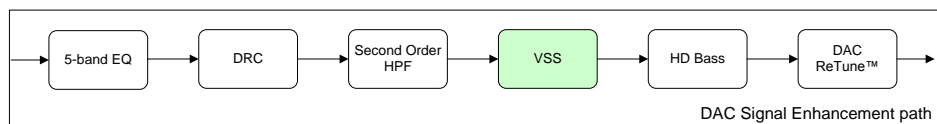
VIRTUAL SURROUND SOUND (VSS)

The Virtual Surround Sound (VSS) function is part of the DAC Signal Enhancement path.

Virtual Sound Sound (VSS) is a digital processing function that creates a perception of wider speaker separation, generating a rich and immersive listening experience. It is aimed at portable applications, but is effective on larger systems also. Note that VSS is not suited to single-speaker systems, nor to headphone outputs.

Portable applications, where the speaker separation is small, suffer from significant acoustic crosstalk, where the Right speaker output is heard strongly in the Left ear, and vice versa. The VSS algorithms are designed to minimise these crosstalk effects, thus increasing the stereo experience. The VSS process is finely tuned to produce a compelling three-dimensional experience, but without the listening fatigue associated with some other stereo enhancement systems.

The VSS algorithms (and the user perception) are most effective at high frequencies; low frequency content is therefore configured to bypass the VSS crosstalk processing. The crossover frequency (for the low-frequency bypass) is adjustable, enabling the user to trade-off the stereo widening effect against the required degree of integrity in the original audio.

The VSS algorithms are programmable and can be optimised for specific application or user geometries. It is recommended to use the DAC HPF in conjunction with VSS in order to prevent distortion and speaker damage.

Before VSS is enabled, it must be initialised and configured using the DSP2_ENA bit described in Table 57. Note that this bit only needs to be enabled once before using any or all of ADC ReTune, DAC ReTune, DAC HPF, VSS or HD Bass.

Note that specific sequences must be followed when enabling or configuring ADC ReTune, DAC ReTune, DAC HPF, VSS, and HD Bass sound enhancement functions (see “Enable Sequence - Enhancements Initially Disabled”).

VSS is enabled using the VSS_ENA register bit as described in Table 57.

It is possible to configure the VSS function to create a stereo effect that is optimised and tailored specifically for a particular application. For the derivation of the VSS configuration parameters in registers R20992 to R21139, refer to the WISCE configuration tool supplied with the WM8962B Evaluation Kit. Note that DSP2_ENA must be enabled before there is any type of access of any of the parameters associated with VSS.

REGISTER ADDRESS	BIT	LABEL	DEFAULT	DESCRIPTION
R768 (R300h) DSP2 Power Management	0	DSP2_ENA	0	DSP2 Audio Processor Enable. 0 = Disabled 1 = Enabled This bit must be set before any of ADC ReTune, DAC ReTune, DAC HPF, VSS or HD Bass is enabled. It must remain set whenever any of these functions is enabled.
R16389 (4005h) SOUNDSTAGE_ENABLES_0	0	VSS_ENA	0	Virtual Surround Sound (VSS) enable 0 = Disabled 1 = Enabled

Table 57 Virtual Surround Sound (VSS) Enable

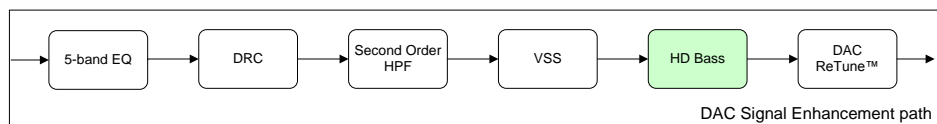
HD BASS

The HD Bass function is part of the DAC Signal Enhancement path.

HD Bass is a dynamic bass boost enhancement which is designed to improve the bass response of small speakers for portable applications in particular. It is also effective on larger speaker systems and on headphones if desired.

HD Bass provides an adaptive gain control of a narrow frequency band towards the low end of the audio spectrum. At low frequencies, where the loudspeaker response is poor, the HD Bass function applies gain in order to increase the bass content of the loudspeaker output. The amount of gain is controlled adaptively, to ensure that distortion is not introduced.

Note that fixed gain can be applied to bass frequencies using the 5-band EQ. The DRC can also apply gain to the DAC signal path. If these enhancements are used in conjunction with HD Bass, then it is important to limit the maximum gain of the 5-band EQ or DRC, to ensure that sufficient headroom is allowed for the HD Bass dynamic boost function.

It is recommended to use the DAC HPF in conjunction with HD Bass in order to prevent distortion and speaker damage.

Before HD Bass is enabled, it must be initialised and configured using the DSP2_ENA bit described in Table 58. Note that this bit only needs to be enabled once before using any or all of ADC ReTune, DAC ReTune, DAC HPF, VSS or HD Bass.

Note that specific sequences must be followed when enabling or configuring ADC ReTune, DAC ReTune, DAC HPF, VSS, and HD Bass sound enhancement functions (see “Enable Sequence - Enhancements Initially Disabled”).

HD Bass is enabled using the HDBASS_ENA register bit as described in Table 58. HD Bass is pre-configured with a default set of parameters, but it is possible to select alternative settings.

For the derivation of the HD Bass configuration parameters in registers R16896 to R16925, refer to the WISCE configuration tool supplied with the WM8962B Evaluation Kit. Note that DSP2_ENA must be enabled before there is any type of access of any of the parameters associated with HD Bass.

REGISTER ADDRESS	BIT	LABEL	DEFAULT	DESCRIPTION
R768 (R300h) DSP2 Power Management	0	DSP2_ENA	0	DSP2 Audio Processor Enable. 0 = Disabled 1 = Enabled This bit must be set before any of ADC ReTune, DAC ReTune, DAC HPF, VSS or HD Bass is enabled. It must remain set whenever any of these functions is enabled.
R16389 (4005h) SOUNDSTAGE_ENABLES_0	3	HDBASS_ENA	0	HD Bass enable 0 = HD Bass disabled 1 = HD Bass enabled

Table 58 HD Bass Control

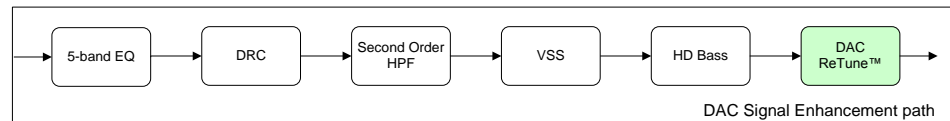
DAC RETUNE

The ReTune function is part of both the ADC and the DAC Signal Enhancement paths. It can be enabled on either path independently. Unique coefficient sets are supported for each path.

ReTune™ is an advanced feature that is intended to perform frequency linearisation according to the particular needs of the application microphone, loudspeaker or housing. The ReTune algorithms can provide acoustic equalisation and selective phase (delay) control of specific frequency bands. In a typical application, ReTune™ is used to flatten the response across the audio frequency band. ReTune™ can also be configured to achieve other response patterns if required.

It is particularly recommended to use ReTune™ to flatten the DAC signal path response when using the VSS or HD Bass functions. The signal processing algorithms of the VSS and HD Bass functions assume a flat system response, and the performance of these enhancements will be compromised if the speaker response is poor or uncalibrated.

Note that, when using ReTune™ to boost any frequency band, it is recommended to take care not to introduce distortion, taking into account the gain that may be applied by other audio enhancement functions.

It is recommended to use the DAC HPF in conjunction with DAC ReTune in order to prevent distortion and speaker damage.

Before ReTune™ is enabled, it must be initialised and configured using the DSP2_ENA bit described in Table 59. Note that this bit only needs to be enabled once before using any or all of ADC ReTune, DAC ReTune, DAC HPF, VSS or HD Bass.

Note that specific sequences must be followed when enabling or configuring ADC ReTune, DAC ReTune, DAC HPF, VSS, and HD Bass sound enhancement functions (see “Enable Sequence - Enhancements Initially Disabled”).

The ReTune function is enabled on the DAC path using the RTN_DAC_ENA register bit as described in Table 59. Under default conditions, the Left and Right channels each use unique tuning coefficients. When the DAC_RETUNE_SCV register is set, then both channels are controlled by the Right channel coefficients.

For the derivation of DAC ReTune configuration parameters in registers R19456 to R20543, the Cirrus WISCE™ software must be used to analyse the requirements of the application (refer to WISCE for further information.) If desired, one or more sets of register coefficients might be derived for different operating scenarios, and these may be recalled and written to the CODEC registers as required in the target application. The DAC ReTune configuration procedure involves the generation and analysis of test signals as outlined below. Note that DSP2_ENA must be enabled before there is any type of access of any of the parameters associated with DAC ReTune.

To determine the characteristics of the loudspeaker in an application, a test signal is applied to the target application. A reference microphone is positioned in the normal acoustic path of the loudspeaker, and the received signal is analysed to determine how accurately the loudspeaker has reproduced the test signal.

Note that the ReTune configuration coefficients are specific to a particular speaker or microphone; it is therefore required that the part-to-part variation in these components is small.

DAC ReTune is controlled using the register bits as described in Table 59.

REGISTER ADDRESS	BIT	LABEL	DEFAULT	DESCRIPTION
R768 (R300h) DSP2 Power Management	0	DSP2_ENA	0	DSP2 Audio Processor Enable. 0 = Disabled 1 = Enabled This bit must be set before any of ADC ReTune, DAC ReTune, DAC HPF, VSS or HD Bass is enabled. It must remain set whenever any of these functions is enabled.
R16386 (4002h) RETUNEDAC_SHARED_COEFF_1	7	DAC_RETUNE_SCV	0	DAC ReTune Coefficient sharing 0 = Left and Right channels each use unique coefficients 1 = Both channels use the Right Channel coefficients
R16389 (4005h) SOUNDSTAGE_ENABLES_0	4	RTN_DAC_ENA	0	DAC ReTune enable 0 = disabled 1 = enabled

Table 59 DAC ReTune Enable

DIGITAL-TO-ANALOGUE CONVERTER (DAC)

The WM8962B DACs receive digital input data from the digital audio interface. The digital audio data is converted to oversampled bit-streams in the on-chip, true 24-bit digital interpolation filters. The bit-stream data enters two multi-bit, sigma-delta DACs, which convert them to high quality analogue audio signals.

The DACs provide digital volume control with soft mute / un-mute. Digital mono mix and de-emphasis filtering is also supported.

The DACs are enabled by the DACL_ENA and DACR_ENA register bits.

REGISTER ADDRESS	BIT	LABEL	DEFAULT	DESCRIPTION
R26 (1Ah) Pwr Mgmt (2)	8	DACL_ENA	0	Left DAC Enable 0 = Disabled 1 = Enabled Note that DACL_ENA must be set to 1 when processing left channel data from the DAC or Digital Beep Generator.
	7	DACR_ENA	0	Right DAC Enable 0 = Disabled 1 = Enabled Note that DACR_ENA must be set to 1 when processing right channel data from the DAC or Digital Beep Generator.

Table 60 DAC Enable Control

DAC CLOCKING CONTROL

Clocking for the DACs is derived from SYSCLK. The required clock is enabled when the SYSCLK_ENA register is set.

The DAC clock rate is configured automatically, according to the SAMPLE_RATE and MCLK_RATE registers. See "Clocking and Sample Rates" for further details of the system clocks and associated control registers.

Note that the DAC and the DAC signal path enhancements functions are only supported under specific clocking configurations. The valid clocking ratios for DAC operation are identified in Table 96. See also Table 97 for details of the supported functions for different MCLK / fs ratios.

DAC DIGITAL VOLUME CONTROL

The output level (digital volume) of each DAC can be controlled digitally over a range from -71.625dB to +23.625dB in 0.375dB steps. The level of attenuation for an eight-bit code X is given by:

$$0.375 \times (X-192) \text{ dB for } 1 \leq X \leq 255; \quad \text{MUTE for } X = 0$$

The DAC_VU bit controls the loading of digital volume control data. When DAC_VU is set to 0, the DACL_VOL or DACR_VOL control data will be loaded into the respective control register, but will not actually change the digital gain setting. Both left and right gain settings are updated when a 1 is written to DAC_VU. This makes it possible to update the gain of both channels simultaneously.

See "DAC Digital Volume Control" section for a description of the volume update function, the zero cross function and the timeout operation.

REGISTER ADDRESS	BIT	LABEL	DEFAULT	DESCRIPTION
R10 (0Ah) Left DAC volume	8	DAC_VU	N/A	DAC Volume Update Writing a 1 to this bit will cause left and right DAC volume to be updated simultaneously
	7:0	DACL_VOL [7:0]	C0h (0dB)	Left DAC Digital Volume Control 00h = Digital Mute 01h = -71.625dB 02h = -71.250dB ... 0.375dB steps up to C0h = 0dB (default) FFh = 23.625dB (See Table 62 for volume range)
R11 (0Bh) Right DAC volume	8	DAC_VU	N/A	DAC Volume Update Writing a 1 to this bit will cause left and right DAC volume to be updated simultaneously
	7:0	DACR_VOL [7:0]	C0h (0dB)	Right DAC Digital Volume Control 00h = Digital Mute 01h = -71.625dB 02h = -71.250dB ... 0.375dB steps up to C0h = 0dB (default) FFh = 23.625dB (See Table 62 for volume range)

Table 61 Digital Volume Control

DACL_VOL or DACR_VOL Volume (dB)		DACL_VOL or DACR_VOL Volume (dB)		DACL_VOL or DACR_VOL Volume (dB)		DACL_VOL or DACR_VOL Volume (dB)	
00	MUTE	40	-48.000	80	-24.000	C0	0.000
01	-71.625	41	-47.625	81	-23.625	C1	0.375
02	-71.250	42	-47.250	82	-23.250	C2	0.750
03	-70.875	43	-46.875	83	-22.875	C3	1.125
04	-70.500	44	-46.500	84	-22.500	C4	1.500
05	-70.125	45	-46.125	85	-22.125	C5	1.875
06	-69.750	46	-45.750	86	-21.750	C6	2.250
07	-69.375	47	-45.375	87	-21.375	C7	2.625
08	-69.000	48	-45.000	88	-21.000	C8	3.000
09	-68.625	49	-44.625	89	-20.625	C9	3.375
0A	-68.250	4A	-44.250	8A	-20.250	CA	3.750
0B	-67.875	4B	-43.875	8B	-19.875	CB	4.125
0C	-67.500	4C	-43.500	8C	-19.500	CC	4.500
0D	-67.125	4D	-43.125	8D	-19.125	CD	4.875
0E	-66.750	4E	-42.750	8E	-18.750	CE	5.250
0F	-66.375	4F	-42.375	8F	-18.375	CF	5.625
10	-66.000	50	-42.000	90	-18.000	D0	6.000
11	-65.625	51	-41.625	91	-17.625	D1	6.375
12	-65.250	52	-41.250	92	-17.250	D2	6.750
13	-64.875	53	-40.875	93	-16.875	D3	7.125
14	-64.500	54	-40.500	94	-16.500	D4	7.500
15	-64.125	55	-40.125	95	-16.125	D5	7.875
16	-63.750	56	-39.750	96	-15.750	D6	8.250
17	-63.375	57	-39.375	97	-15.375	D7	8.625
18	-63.000	58	-39.000	98	-15.000	D8	9.000
19	-62.625	59	-38.625	99	-14.625	D9	9.375
1A	-62.250	5A	-38.250	9A	-14.250	DA	9.750
1B	-61.875	5B	-37.875	9B	-13.875	DB	10.125
1C	-61.500	5C	-37.500	9C	-13.500	DC	10.500
1D	-61.125	5D	-37.125	9D	-13.125	DD	10.875
1E	-60.750	5E	-36.750	9E	-12.750	DE	11.250
1F	-60.375	5F	-36.375	9F	-12.375	DF	11.625
20	-60.000	60	-36.000	A0	-12.000	E0	12.000
21	-59.625	61	-35.625	A1	-11.625	E1	12.375
22	-59.250	62	-35.250	A2	-11.250	E2	12.750
23	-58.875	63	-34.875	A3	-10.875	E3	13.125
24	-58.500	64	-34.500	A4	-10.500	E4	13.500
25	-58.125	65	-34.125	A5	-10.125	E5	13.875
26	-57.750	66	-33.750	A6	-9.750	E6	14.250
27	-57.375	67	-33.375	A7	-9.375	E7	14.625
28	-57.000	68	-33.000	A8	-9.000	E8	15.000
29	-56.625	69	-32.625	A9	-8.625	E9	15.375
2A	-56.250	6A	-32.250	AA	-8.250	EA	15.750
2B	-55.875	6B	-31.875	AB	-7.875	EB	16.125
2C	-55.500	6C	-31.500	AC	-7.500	EC	16.500
2D	-55.125	6D	-31.125	AD	-7.125	ED	16.875
2E	-54.750	6E	-30.750	AE	-6.750	EE	17.250
2F	-54.375	6F	-30.375	AF	-6.375	EF	17.625
30	-54.000	70	-30.000	B0	-6.000	F0	18.000
31	-53.625	71	-29.625	B1	-5.625	F1	18.375
32	-53.250	72	-29.250	B2	-5.250	F2	18.750
33	-52.875	73	-28.875	B3	-4.875	F3	19.125
34	-52.500	74	-28.500	B4	-4.500	F4	19.500
35	-52.125	75	-28.125	B5	-4.125	F5	19.875
36	-51.750	76	-27.750	B6	-3.750	F6	20.250
37	-51.375	77	-27.375	B7	-3.375	F7	20.625
38	-51.000	78	-27.000	B8	-3.000	F8	21.000
39	-50.625	79	-26.625	B9	-2.625	F9	21.375
3A	-50.250	7A	-26.250	BA	-2.250	FA	21.750
3B	-49.875	7B	-25.875	BB	-1.875	FB	22.125
3C	-49.500	7C	-25.500	BC	-1.500	FC	22.500
3D	-49.125	7D	-25.125	BD	-1.125	FD	22.875
3E	-48.750	7E	-24.750	BE	-0.750	FE	23.250
3F	-48.375	7F	-24.375	BF	-0.375	FF	23.625

Table 62 DAC Digital Volume Range

DAC SOFT MUTE AND UN-MUTE

A signal can be muted and unmuted using the DAC_MUTE register. The type of muting or unmuting performed (hard or soft) is controlled by the DAC_MUTE_RAMP and DAC_UNMUTE_RAMP registers.

Note that the DAC is muted by default. To play back an audio signal, this function must first be disabled by setting the DAC_MUTE bit to zero.

If DAC_MUTE_RAMP = 0 when a signal is muted, any muting of the output volume is instantaneous (a 'hard' mute). If DAC_MUTE_RAMP = 1 ('soft' mute), the signal is gradually attenuated until the volume of the digital signal reaches zero, as illustrated in Figure 32.

Similarly, the hard and soft unmute functions are controlled by the DAC_UNMUTE_RAMP register. If DAC_UNMUTE_RAMP = 0, the signal gain returns instantaneously to the current PGA gain setting. If DAC_UNMUTE_RAMP = 1, the signal is gradually boosted until the volume of the digital signal reaches the current PGA gain setting. This is illustrated in Figure 32.

DAC_UNMUTE_RAMP would typically be enabled when using soft mute during playback of audio data so that when mute is then disabled, the sudden volume increase will not create pop noise by jumping immediately to the previous volume level (e.g. resuming playback after pausing during a track).

DAC_UNMUTE_RAMP would typically be disabled when un-muting at the start of a digital music file, so that the first part of the track is not attenuated (e.g. when starting playback of a new track, or resuming playback after pausing between tracks).

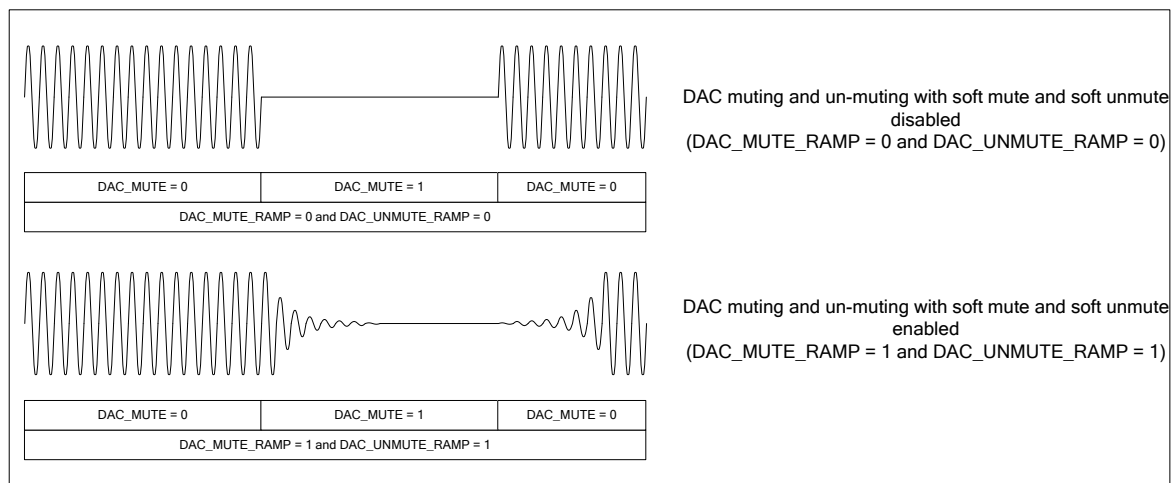

Figure 32 DAC Mute Control

The volume ramp rate during soft mute and un-mute is controlled by the DAC_MUTERATE bit as shown in Table 63.

REGISTER ADDRESS	BIT	LABEL	DEFAULT	DESCRIPTION
R5 (05h) ADC & DAC Control 1	4	DAC_MUTE_RAMP	1	DAC Soft Mute Control 0 = Muting the DAC (DAC_MUTE = 1) will cause the volume to change immediately to mute. 1 = Muting the DAC (DAC_MUTE = 1) will cause the volume to ramp down gradually to mute.
	3	DAC_MUTE	1	Digital DAC Mute 0 = Un-mute 1 = Mute Note that this bit also exists in R49. Reading or writing to either location has the same effect.
R49 (31h)	4	DAC_MUTE	1	Digital DAC Mute 0 = Un-mute 1 = Mute Note that this bit also exists in R5. Reading or writing to either location has the same effect.
R6 (06h) ADC & DAC Control 2	3	DAC_UNMUTE_RAMP	1	DAC Soft Unmute Control 0 = Unmuting the DAC (DAC_MUTE = 0) will cause the volume to change immediately to the DACL_VOL/DACR_VOL settings. 1 = Unmuting the DAC (DAC_MUTE = 0) will cause the volume to ramp up gradually to the DACL_VOL/DACR_VOL settings.
	2	DAC_MUTERATE	0	DAC Soft Mute Ramp Rate 0 = Fast ramp (maximum ramp time 10.7ms) 1 = Slow ramp (maximum ramp time 171ms). Note that the ramp rate scales with sample rate (fs). Quoted values are correct for fs = 48kHz.

Table 63 DAC Soft-Mute Control

DAC AUTO-MUTE

The DAC digital mute and volume controls are described earlier in Table 61 and Table 63.

The DAC also incorporates a digital auto-mute monitor, which is enabled by setting DAC_AUTOMUTE. When the auto-mute is enabled, and a number (DAC_AUTOMUTE_SAMPLES) of consecutive zero-samples is detected, the AUTOMUTE_STS flag is asserted.

The WM8962B supports the option to automatically power-down the speaker path when the DAC Auto-Mute is triggered, and to re-enable the speaker path when audio data is detected. This feature has been designed to work around the Write Sequencer, which mutes and unmutes the speakers in a controlled manner using the Speaker Sleep (see Table 129) and Speaker Wake (see Table 130) write sequences. Auto-mute is enabled by setting the WSEQ_AUTOSEQ_ENA bit in Register R87. See Table 64 for details of this and other Auto-mute register bits.

The status of DAC Auto-Mute can be read back from the AUTOMUTE_STS bit.

REGISTER ADDRESS	BIT	LABEL	DEFAULT	DESCRIPTION
R9 (09h) Audio Interface 0	11	AUTOMUTE_STS	0	Readback of the DAC Automute status 0 = Automute not detected 1 = Automute detected
	9:8	DAC_AUTOMUTE_SAMPLES [1:0]	11	Selects the number of consecutive zero DAC samples that will be interpreted as an Automute. 00 = 128 samples 01 = 256 samples 10 = 512 samples 11 = 1024 samples
	7	DAC_AUTOMUTE	0	DAC Auto-Mute Control 0 = Disabled 1 = Enabled
R87 (57h) Write Sequencer Control 1	7	WSEQ_AUTOSEQ_ENA	0	Write Sequencer Auto-Sequence Enable (controls the Class D driver via DAC Auto-Mute function) 0 = Disabled 1 = Enabled

Table 64 DAC Auto Mute

DAC MONO MIX

A DAC digital mono-mix mode can be enabled using the DAC_MONOMIX register bit. This mono mix will be output on whichever DAC is enabled. To prevent clipping, a -6dB attenuation is automatically applied to the mono mix.

The mono mix is only supported when one or other DAC is disabled. When the mono mix is selected, then the mono mix is output on the enabled DAC only; there is no output from the disabled DAC. If DACL_ENA and DACR_ENA are both set, then stereo operation applies.

REGISTER ADDRESS	BIT	LABEL	DEFAULT	DESCRIPTION
R57(39h) DAC DSP Mixing (1)	9	DAC_MONOMIX	0	DAC Mono Mix 0 = Stereo 1 = Mono (Mono mix output on enabled DAC) Mono Mix is only supported when one or other DAC is disabled. When Mono mix is enabled, 6dB attenuation is applied.

Table 65 DAC Mono Mix

DAC DE-EMPHASIS

Digital de-emphasis can be applied to the DAC playback data (e.g. when the data comes from a CD with pre-emphasis used in the recording). De-emphasis filtering is available for sample rates of 48kHz, 44.1kHz and 32kHz.

REGISTER ADDRESS	BIT	LABEL	DEFAULT	DESCRIPTION
R5 (05h) ADC & DAC Control 1	2:1	DAC_DEEMP [1:0]	00	De-Emphasis Control 00 = No de-emphasis 01 = De-emphasis for 32kHz sample rate 10 = De-emphasis for 44.1kHz sample rate 11 = De-emphasis for 48kHz sample rate

Table 66 DAC De-Emphasis Control
DAC OVERSAMPLING RATIO (OSR)

The DAC oversampling rate is programmable to allow power consumption versus audio performance trade-offs. The default oversampling rate is low for reduced power consumption; using the higher OSR setting improves the DAC signal-to-noise performance.

See the “Reference Voltages and Bias Control” section for details of the supported bias control settings for the output signal paths.

REGISTER ADDRESS	BIT	LABEL	DEFAULT	DESCRIPTION
R6 (06h) ADC & DAC Control 2	0	DAC_HP	0	DAC Oversampling Ratio 0 = Low Power (typically 64 x fs) 1 = High Performance (typically 128 x fs)

Table 67 DAC Oversampling Control

DIGITAL BEEP GENERATOR

The WM8962B provides a digital signal generator which can be used to inject an audio tone (beep) into the DAC signal path. The output of the beep generator is digitally mixed with the DAC outputs, after the DAC digital volume.

The beep is enabled using BEEP_ENA. The beep function creates an approximation of a Sine wave. The audio frequency is set using BEEP_RATE, and is dependent on the SAMPLE_RATE_INT_MODE and the SAMPLE_RATE settings (see “Clocking and Sample Rates” section). The beep volume is set using BEEP_GAIN. Note that the volume of the digital beep generator is not affected by the DAC volume or DAC mute controls.

The digital beep generator control fields are described in Table 68.

REGISTER ADDRESS	BIT	LABEL	DEFAULT	DESCRIPTION
R110 (6Eh) Beep Generator (1)	7:4	BEEP_GAIN [3:0]	0000	Digital Beep Volume Control 0000 = mute 0001 = -90dB 0010 = -84dB ... (6dB steps) 1111 = -6dB
	2:1	BEEP_RATE [1:0]	01	Digital Beep Waveform Control If SAMPLE_RATE_INT_MODE = 1 00 = 500Hz 01 = 1000Hz 10 = 2000Hz 11 = 4000Hz If SAMPLE_RATE_INT_MODE = 0 00 = 499Hz – 502Hz 01 = 999Hz – 1003Hz 10 = 1998Hz – 2005Hz 11 = 3997Hz – 4009Hz
	0	BEEP_ENA	0	Digital Beep Enable 0 = Disabled 1 = Enabled Note that the DAC and associated signal path needs to be enabled when using the digital beep.

Table 68 Digital Beep Generator

OUTPUT SIGNAL PATH

The WM8962B input routing and mixers provide a high degree of flexibility, allowing operation of many simultaneous signal paths through the device to the output devices. The analogue output devices are a pair of stereo Headphone Output drivers and a pair of Speaker Output drivers. Support for mono signal output is also provided.

The output signal paths and associated control registers are illustrated in Figure 33.

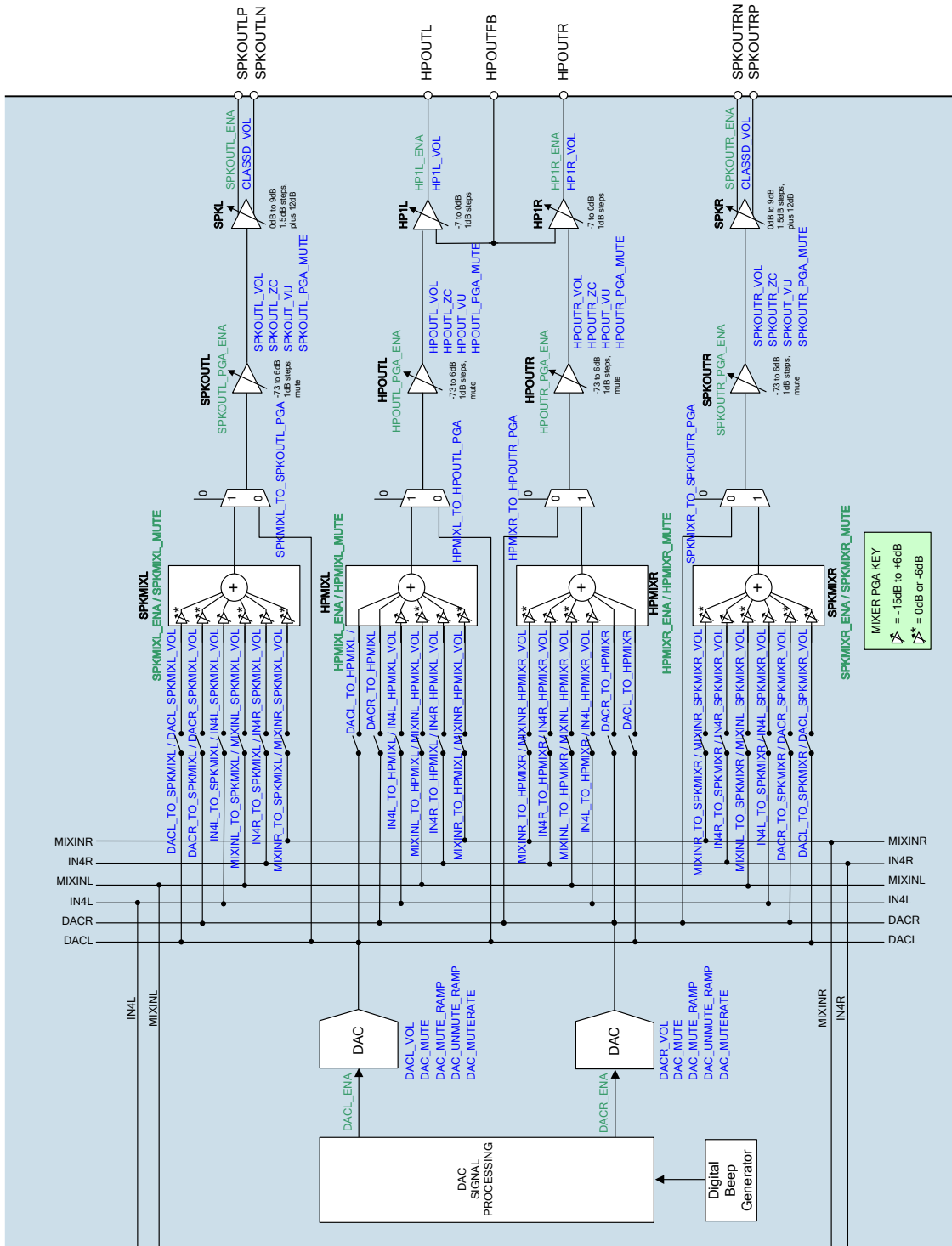

Figure 33 Output Signal Paths

OUTPUT SIGNAL PATHS ENABLE

The four output mixers, and each analogue output pin and associated PGA, can be independently enabled or disabled using the register bits described in Table 69.

The Class D speaker drivers are controlled using SPKOUTL_ENA and SPKOUTR_ENA. The headphone drivers are controlled by HP1L_ENA and HP1R_ENA.

To enable the output PGAs, the reference voltage VMID and the bias current must also be enabled. See "Reference Voltages and Bias Control" for details of the associated controls VMID_SEL and BIAS_ENA.

Note that the Speaker and Headphone outputs, the Speaker and Headphone PGAs, and the Speaker and headphone mixers are all disabled by default. The required signal paths must be enabled and unmuted using the control bits described in the respective tables below.

REGISTER ADDRESS	BIT	LABEL	DEFAULT	DESCRIPTION
R26 (1Ah) Pwr Mgmt (2)	6	HPOUTL_PGA_ENA	0	Headphone Left PGA enable 0 = Disabled 1 = Enabled
	5	HPOUTR_PGA_ENA	0	Headphone Right PGA enable 0 = Disabled 1 = Enabled
	4	SPKOUTL_PGA_ENA	0	Speaker Left PGA enable 0 = Disabled 1 = Enabled
	3	SPKOUTR_PGA_ENA	0	Speaker Right PGA enable 0 = Disabled 1 = Enabled
R49 (31h) Class D Control (1)	7	SPKOUTR_ENA	0	Right channel class D Speaker Enable 0 = Disabled 1 = Enabled
	6	SPKOUTL_ENA	0	Left channel class D Speaker Enable 0 = Disabled 1 = Enabled
R69 (45h) Analogue HP 0	4	HP1L_ENA	0	Enables HP1L input stage 0 = Disabled 1 = Enabled For normal operation, this bit should be set as the final stage of the HP1L Enable sequence.
	0	HP1R_ENA	0	Enables HP1R input stage 0 = Disabled 1 = Enabled For normal operation, this bit should be set as the final stage of the HP1R Enable sequence.
R99 (63h) Mixer Enables	3	HPMIXL_ENA	0	Left Headphone Mixer Enable 0 = Disabled 1 = Enabled
	2	HPMIXR_ENA	0	Right Headphone Mixer Enable 0 = Disabled 1 = Enabled
	1	SPKMIXL_ENA	0	Left Speaker Mixer Enable 0 = Disabled 1 = Enabled
	0	SPKMIXR_ENA	0	Right Speaker Mixer Enable 0 = Disabled 1 = Enabled

Table 69 Output Signal Paths Enable

SPEAKER OUTPUT PATHS

The following sections describe all the speaker output paths and controls. For information on the headphone output paths and controls, refer to the “Headphone Output Paths” section.

SPEAKER MIXER CONTROL

The two speaker mixers - SPKMIXL and SPKMIXR – can each have any combination of the six available input paths enabled as described in Table 70 (left speaker mixer) and Table 71 (right speaker mixer). The six input signal paths are two from the DACs (DACL and DACR), two from the input mixers (MIXINL and MIXINR) and two bypass paths direct from the IN4 input pins (IN4L and IN4R). The speaker mixers are muted by default.

The two signal paths from the left and right DACs to each of the two speaker mixers SPKMIXL and SPKMIXR are enabled using the register bits DACL_TO_SPKMIXL, DACL_TO_SPKMIXR, DACR_TO_SPKMIXL and DACR_TO_SPKMIXR. A selectable -6dB control is available on each of these paths to help avoid signal clipping.

The two DAC output signals can also be configured to bypass the speaker mixers using the SPKMIXL_TO_SPKOUTL_PGA and SPKMIXR_TO_SPKOUTR_PGA register bits. Note that the DAC output signals bypass the mixers by default.

The direct signal paths from each of the input mixers MIXINL and MIXINR to each of the speaker mixers SPKMIXL and SPKMIXR are enabled using the MIXINL_TO_SPKMIXL, MIXINL_TO_SPKMIXR, MIXINR_TO_SPKMIXL and MIXINR_TO_SPKMIXR register bits. A selectable -6dB control is available on each of these paths to help avoid signal clipping.

The direct signal paths from the IN4L and IN4R input pins to the speaker mixers SPKMIXL and SPKMIXR are enabled using the IN4L_TO_SPKMIXL, IN4L_TO_SPKMIXR, IN4R_TO_SPKMIXL, and IN4R_TO_SPKMIXR register bits. Each input signal path from IN4 also has an associated PGA with a gain range from -15dB to +6dB.

REGISTER ADDRESS	BIT	LABEL	DEFAULT	DESCRIPTION
R105 (69h) Speaker Mixer (1)	7	SPKMIXL_TO_SPKOUTL_PGA	0	Left Speaker PGA Path Select 0 = DACL Output 1 = SPKMIXL Output
	5	DACL_TO_SPKMIXL	0	Left DAC to Left Speaker Mixer select 0 = Disabled 1 = Enabled
	4	DACR_TO_SPKMIXL	0	Right DAC to Left Speaker Mixer select 0 = Disabled 1 = Enabled
	3	MIXINL_TO_SPKMIXL	0	Left Input Mixer to Left Speaker Mixer select 0 = Disabled 1 = Enabled
	2	MIXINR_TO_SPKMIXL	0	Right Input Mixer to Left Speaker Mixer select 0 = Disabled 1 = Enabled
	1	IN4L_TO_SPKMIXL	0	Input IN4L to Left Speaker Mixer select 0 = Disabled 1 = Enabled
	0	IN4R_TO_SPKMIXL	0	Input IN4R to Left Speaker Mixer select 0 = Disabled 1 = Enabled

REGISTER ADDRESS	BIT	LABEL	DEFAULT	DESCRIPTION
R107 (6Bh) Speaker Mixer (3)	8	SPKMIXL_MUTE	1	Left Speaker Mixer Mute 0 = Unmuted 1 = Muted
	7	MIXINL_SPKMIXL_VOL	0	Left Input Mixer to Left Speaker Mixer volume 0 = 0dB 1 = -6dB
	6	MIXINR_SPKMIXL_VOL	0	Right Input Mixer to Left Speaker Mixer volume 0 = 0dB 1 = -6dB
	5:3	IN4L_SPKMIXL_VOL	111	Input IN4L to Left Speaker Mixer Volume control 000 = -15dB 001 = -12dB 010 = -9dB 011 = -6dB 100 = -3dB 101 = 0dB 110 = +3dB 111 = +6dB
	2:0	IN4R_SPKMIXL_VOL	111	Input IN4R to Left Speaker Mixer Volume control 000 = -15dB 001 = -12dB 010 = -9dB 011 = -6dB 100 = -3dB 101 = 0dB 110 = +3dB 111 = +6dB
R109 (6Dh) Speaker Mixer (5)	7	DACL_SPKMIXL_VOL	0	Left DAC to Left Speaker Mixer volume 0 = 0dB 1 = -6dB
	6	DACR_SPKMIXL_VOL	0	Right DAC to Left Speaker Mixer volume 0 = 0dB 1 = -6dB

Table 70 Left Speaker Mixer Control

REGISTER ADDRESS	BIT	LABEL	DEFAULT	DESCRIPTION
R106 (6Ah) Speaker Mixer (2)	7	SPKMIXR_TO_SPKOUTR_PGA	0	Right Speaker PGA Path Select 0 = DACR Output 1 = SPKMIXR Output
	5	DACL_TO_SPKMIXR	0	Left DAC to Right Speaker Mixer select 0 = Disabled 1 = Enabled
	4	DACR_TO_SPKMIXR	0	Right DAC to Right Speaker Mixer select 0 = Disabled 1 = Enabled

REGISTER ADDRESS	BIT	LABEL	DEFAULT	DESCRIPTION
	3	MIXINL_TO_SPK MIXR	0	Left Input Mixer to Right Speaker Mixer select 0 = Disabled 1 = Enabled
	2	MIXINR_TO_SPK MIXR	0	Right Input Mixer to Right Speaker Mixer select 0 = Disabled 1 = Enabled
	1	IN4L_TO_SPKMI XR	0	Input IN4L to Right Speaker Mixer select 0 = Disabled 1 = Enabled
	0	IN4R_TO_SPKMI XR	0	Input IN4R to Right Speaker Mixer select 0 = Disabled 1 = Enabled
R108 (6Ch) Speaker Mixer (4)	8	SPKMIXR_MUTE	1	Right Speaker Mixer Mute 0 = Unmuted 1 = Muted
	7	MIXINL_SPKMIX R_VOL	0	Left Input Mixer to Right Speaker Mixer volume 0 = 0dB 1 = -6dB
	6	MIXINR_SPKMIX R_VOL	0	Right Input Mixer to Right Speaker Mixer volume 0 = 0dB 1 = -6dB
	5:3	IN4L_SPKMIXR_VOL	111	Input IN4L to Right Speaker Mixer Volume control 000 = -15dB 001 = -12dB 010 = -9dB 011 = -6dB 100 = -3dB 101 = 0dB 110 = +3dB 111 = +6dB
	2:0	IN4R_SPKMIXR_VOL	111	Input IN4R to Right Speaker Mixer Volume control 000 = -15dB 001 = -12dB 010 = -9dB 011 = -6dB 100 = -3dB 101 = 0dB 110 = +3dB 111 = +6dB
R109 (6Dh) Speaker Mixer (5)	5	DACL_SPKMIXR_VOL	0	Left DAC to Right Speaker Mixer volume 0 = 0dB 1 = -6dB
	4	DACR_SPKMIXR_VOL	0	Right DAC to Right Speaker Mixer volume 0 = 0dB 1 = -6dB

Table 71 Right Speaker Mixer Control

SPEAKER OUTPUT PGA CONTROL

There are four speaker output PGAs – two primary (SPKOUTL and SPKOUTR), and two secondary (SPKL, SPKR). The speaker outputs are each controlled by a primary PGA and a secondary PGA in series.

The SPKOUTL and SPKOUTR PGAs give a high degree of control from -68dB to +6dB in 1dB steps. A detailed table of all SPKOUTL and SPKOUTR gain settings is shown in Table 73. Dedicated secondary PGAs are provided for each of the SPKOUT output pins. The secondary PGAs provide control from 0dB to +9dB in 1.5dB steps, and +12dB, on each channel. See Figure 33 for a representation of this layout.

The direct signal paths from the IN4L and IN4R input pins to the speaker mixers SPKMIXL and SPKMIXR are enabled using the IN4L_TO_SPKMIXL, IN4L_TO_SPKMIXR, IN4R_TO_SPKMIXL, and IN4R_TO_SPKMIXR register bits. Each input signal path from IN4 also has an associated PGA with a gain range from -15dB to +6dB.

To minimise pop and zipper noise, it is recommended that only SPKOUTL PGA and SPKOUTR PGA are modified while the output signal path is active as these are the only Speaker PGAs with Zero Cross. In the case of a long period without zero-crossings, a timeout function is provided. When the zero-cross function is enabled, the volume will update after the timeout period if no earlier zero-cross has occurred. The timeout clock is enabled using TOCLK_ENA; the timeout period is set by TOCLK_DIV. See "Clocking and Sample Rates" for more information on these fields. It is recommended that the other gain controls on the signal paths should not be modified while the signal path is active.

The left and right channels on the SPKOUT pins can be boosted using the CLASSD_VOL register. Note that both left and right channels are updated simultaneously with the CLASSD_VOL register.

The speaker output signal can be muted using the SPKOUTL_PGA_MUTE and SPKOUTR_PGA_MUTE registers. The speaker outputs are un-muted by default.

The SPKOUT_VU bits control the loading of the speaker PGA volume data. When SPKOUT_VU is set to 0, the volume control data will be loaded into the respective control register, but will not actually change the gain setting. The left and right Speaker PGA volume settings are both updated when a 1 is written to any of the SPKOUT_VU bits. This makes it possible to update the gain of the left and right output paths simultaneously.

The Speaker PGA volume control register fields are described in Table 72.

REGISTER ADDRESS	BIT	LABEL	DEFAULT	DESCRIPTION
R40 (28h) SPKOUTL volume	8	SPKOUT_VU	N/A	Speaker Output PGA Volume Update Writing a 1 to this bit will update SPKOUTL_VOL and SPKOUTR_VOL volumes simultaneously.
	7	SPKOUTL_ZC	0	SPKOUTL_VOL (Left Speaker Output PGA) Zero Cross Enable 0 = Zero cross disabled 1 = Zero cross enabled
	6:0	SPKOUTL_VOL [6:0]	00h (Mute)	Left Speaker Output PGA Volume 000_0000 to 010_1111 = Mute 011_0000 to 011_0101 = -68dB 011_0110 = -67dB ...in 1dB steps 111_1001 = 0dB ... 111_1111 = +6dB (See Table 73 for output PGA volume control range)

REGISTER ADDRESS	BIT	LABEL	DEFAULT	DESCRIPTION
R41 (29h) SPKOUTR volume	8	SPKOUT_VU	N/A	Speaker Output PGA Volume Update Writing a 1 to this bit will update SPKOUTL_VOL and SPKOUTR_VOL volumes simultaneously.
	7	SPKOUTR_ZC	0	SPKOUTR_VOL (Right Speaker Output PGA) Zero Cross Enable 0 = Zero cross disabled 1 = Zero cross enabled
	6:0	SPKOUTR_VOL [6:0]	00h (Mute)	Right Speaker Output PGA Volume 000_0000 to 010_1111 = Mute 011_0000 to 011_0101 = -68dB 011_0110 = -67dB ...in 1dB steps 111_1001 = 0dB ... 111_1111 = +6dB (See Table 73 for output PGA volume control range)
R49 (31h) Class D Control 1	2	SPKOUT_VU	N/A	Speaker Output PGA Volume Update Writing a 1 to this bit will update SPKOUTL_VOL and SPKOUTR_VOL volumes simultaneously.
	1	SPKOUTL_PGA_MUTE	0	SPKOUTL_VOL (Left Speaker Output PGA) Mute 0 = Un-mute 1 = Mute
	0	SPKOUTR_PGA_MUTE	0	SPKOUTR_VOL (Right Speaker Output PGA) Mute 0 = Un-mute 1 = Mute

Table 72 Speaker Output PGA (SPKOUTL_VOL, SPKOUTR_VOL) Control

HPOUTL_VOL [6:0], HPOUTR_VOL [6:0], SPKOUTL_VOL [6:0] or SPKOUTR_VOL [6:0]	VOLUME (dB)	HPOUTL_VOL [6:0], HPOUTR_VOL [6:0], SPKOUTL_VOL [6:0] or SPKOUTR_VOL [6:0]	VOLUME (dB)
000_0000 to 010_1111	Mute	101_1010	-31
011_0000 to 011_0101	-68	101_1011	-30
011_0110	-67	101_1100	-29
011_0111	-66	101_1101	-28
011_1000	-65	101_1110	-27
011_1001	-64	101_1111	-26
011_1010	-63	110_0000	-25
011_1011	-62	110_0001	-24
011_1100	-61	110_0010	-23
011_1101	-60	110_0011	-22
011_1110	-59	110_0100	-21
011_1111	-58	110_0101	-20
100_0000	-57	110_0110	-19
100_0001	-56	110_0111	-18
100_0010	-55	110_1000	-17
100_0011	-54	110_1001	-16
100_0100	-53	110_1010	-15
100_0101	-52	110_1011	-14
100_0110	-51	110_1100	-13
100_0111	-50	110_1101	-12
100_1000	-49	110_1110	-11
100_1001	-48	110_1111	-10
100_1010	-47	111_0000	-9
100_1011	-46	111_0001	-8
100_1100	-45	111_0010	-7
100_1101	-44	111_0011	-6
100_1110	-43	111_0100	-5
100_1111	-42	111_0101	-4
101_0000	-41	111_0110	-3
101_0001	-40	111_0111	-2
101_0010	-39	111_1000	-1
101_0011	-38	111_1001	0
101_0100	-37	111_1010	+1
101_0101	-36	111_1011	+2
101_0110	-35	111_1100	+3
101_0111	-34	111_1101	+4
101_1000	-33	111_1110	+5
101_1001	-32	111_1111	+6

Table 73 Headphone PGA and Speaker PGA Volume Range

SPEAKER OUTPUT CONFIGURATIONS

The speaker outputs SPKOUT are driven by the two speaker PGAs SPKOUTL and SPKOUTR. Fine volume control is available on the speaker paths using the SPKOUTL_VOL and SPKOUTR_VOL PGAs. A volume boost function (CLASSD_VOL) is available on both the speaker paths.

The speaker outputs SPKOUTL and SPKOUTR operate in a BTL configuration in Class D amplifier mode.

The speaker outputs can be configured as a pair of stereo outputs, or as a single mono output. Note that, for applications requiring only a single speaker output, it is possible to improve the THD performance by configuring the speaker outputs in mono mode. See “Electrical Characteristics” for further details.

The mono configuration is selected using the SPK_MONO register bit, as described in Table 74. In mono mode, the P channels, SPKOUTLP and SPKOUTRP should be connected together on the PCB, and similarly with the N channels, SPKOUTLN and SPKOUTRN, as illustrated in Figure 34. In this configuration both left and right speaker drivers should be enabled (SPKOUTL_ENA=1 and SPKOUTR_ENA=1), but both drivers will output the left speaker path signal only.

The connections for stereo and mono speaker configurations are shown in Figure 34.

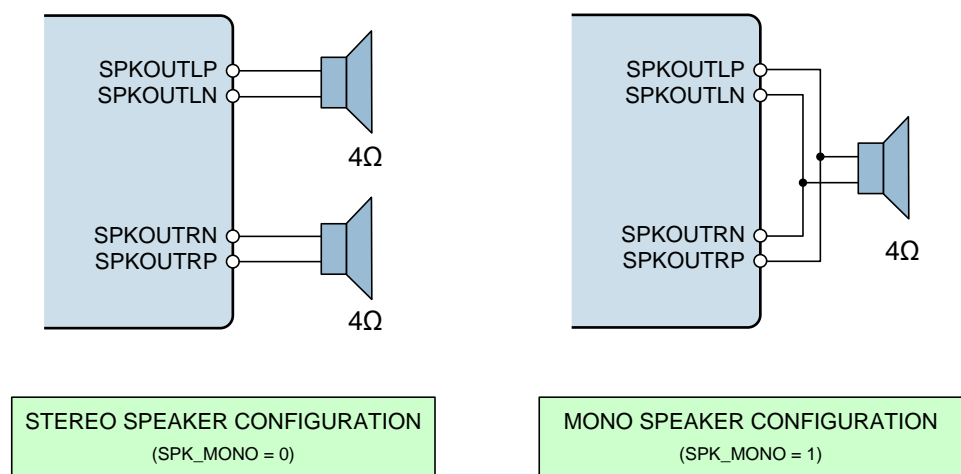
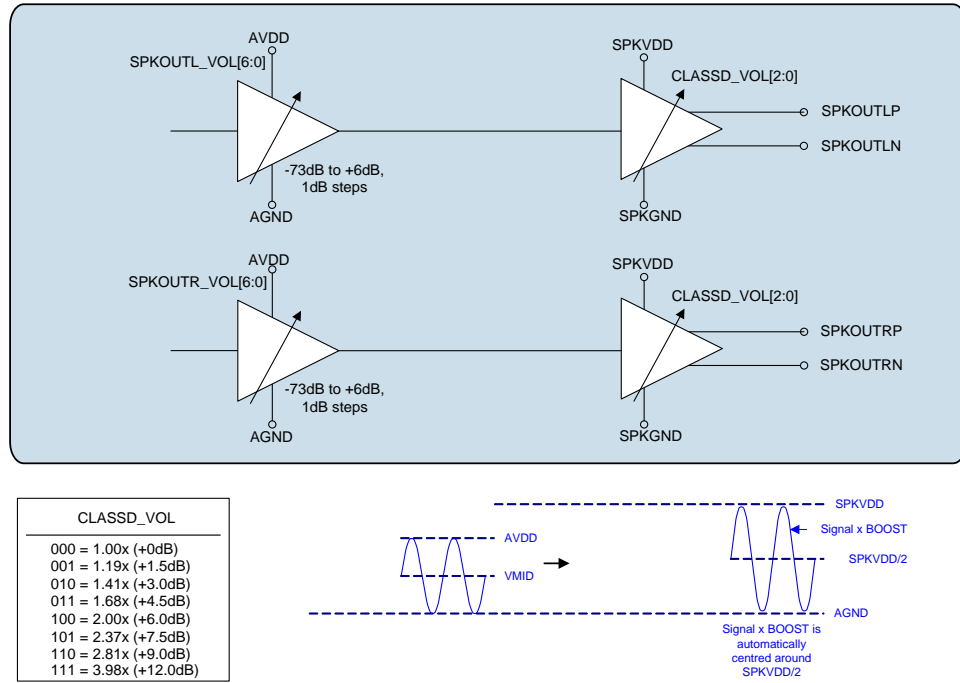

Figure 34 Mono and Stereo Speaker Output Configuration

Eight levels of AC signal boost are provided in order to deliver maximum output power for many commonly-used SPKVDD/AVDD combinations. The AC boost levels from 0dB to +12dB are selected using register bit CLASSD_VOL, which boosts left and right channels equally. To prevent pop noise, CLASSD_VOL should not be modified while the speaker outputs are enabled. Figure 35 illustrates the speaker outputs and gain/boost options available.

Ultra-low leakage and high PSRR allow the speaker supply SPKVDD to be directly connected to a lithium battery. Note that an appropriate SPKVDD supply voltage must be provided to prevent waveform clipping when speaker boost is used.

DC gain is applied automatically with a shift from VMID to SPKVDD/2. This provides optimum signal swing for maximum output power.

Figure 35 Speaker Output Configuration and AC Boost Operation

REGISTER ADDRESS	BIT	LABEL	DEFAULT	DESCRIPTION
R51 (33h) Class D Control 2	6	SPK_MONO	0	Mono Speaker Configuration enable 0 = Default (stereo) 1 = Mono mode When SPK_MONO is set to '1', both speakers output the signal from the left channel. Note that the user must tie the outputs together for mono use
	2:0	CLASSD_VOL	011	AC Speaker Gain Boost. Note that both left and right channels are boosted equally 000 = 1.00x boost (+0dB) 001 = 1.19x boost (+1.5dB) 010 = 1.41x boost (+3.0dB) 011 = 1.68x boost (+4.5dB) 100 = 2.00x boost (+6.0dB) 101 = 2.37x boost (+7.5dB) 110 = 2.81x boost (+9.0dB) 111 = 3.98x boost (+12.0dB)

Table 74 Class D Speaker Driver Control

HEADPHONE OUTPUT PATHS

The following sections describe all the headphone output paths and controls. For information on the speaker output paths and controls, refer to the earlier “Speaker Output Paths” section.

HEADPHONE SIGNAL PATHS ENABLE

The WM8962B headphone drivers incorporate Wolfson’s SilentSwitch technology which enables pops normally associated with Start-Up, Shut-Down or signal path control to be suppressed. To achieve maximum benefit from these features, careful attention is required to the sequence and timing of these controls. Note that, under the recommended usage conditions of the WM8962B, these features will be configured by running the default Start-Up and Shut-Down sequences as described in the “Control Write Sequencer” section. In these cases, the user does not need to set these register fields directly.

The Headphone output drivers can be actively switched to AGND through internal resistors if desired. This is desirable at start-up in order to achieve a known condition prior to enabling the output. This is also desirable in shutdown to prevent the external connections from being affected by the internal circuits. The HPOUTL and HPOUTR outputs are shorted to AGND by default; the short circuit is removed on each of these paths by setting the applicable fields HP1L_RMV_SHORT and HP1R_RMV_SHORT.

The ground-referenced Headphone output drivers are designed to suppress pops and clicks when enabled or disabled. However, it is necessary to control the drivers in accordance with a defined sequence in start-up and shut-down to achieve the pop suppression. It is also necessary to schedule the DC Servo offset correction at the appropriate point in the sequence (see “DC Servo”). Table 75 and Table 76 describe the recommended sequences for enabling and disabling these output drivers.

SEQUENCE	HPOUT ENABLE
Step 1	HP1L_ENA = 1 HP1R_ENA = 1
Step 2	20 μ s delay
Step 3	HP1L_ENA_DLY = 1 HP1R_ENA_DLY = 1
Step 4	DC offset correction
Step 5	HP1L_ENA_OUTP = 1 HP1R_ENA_OUTP = 1
Step 6	20 μ s delay
Step 7	HP1L_RMV_SHORT = 1 HP1R_RMV_SHORT = 1

Table 75 Headphone Output Enable Sequence

SEQUENCE	HPOUT DISABLE
Step 1	HP1L_RMV_SHORT = 0 HP1R_RMV_SHORT = 0
Step 2	20 μ s delay
Step 3	HP1L_ENA = 0 HP1L_ENA_DLY = 0 HP1L_ENA_OUTP = 0 HP1R_ENA = 0 HP1R_ENA_DLY = 0 HP1R_ENA_OUTP = 0

Table 76 Headphone Output Disable Sequence

The register bits relating to pop suppression control are defined in Table 77.

REGISTER ADDRESS	BIT	LABEL	DEFAULT	DESCRIPTION
R69 (45h) Analogue HP 0	7	HP1L_RMV_SHORT	0	Removes HP1L short 0 = HP1L short enabled 1 = HP1L short removed For pop-free operation, this bit should be set to 1 as the final step in the HP1L Enable sequence.
	6	HP1L_ENA_OUTP	0	Enables HP1L output stage 0 = Disabled 1 = Enabled For pop-free operation, this bit should be set to 1 after the DC offset cancellation has been performed.
	5	HP1L_ENA_DLY	0	Enables HP1L intermediate stage 0 = Disabled 1 = Enabled For pop-free operation, this bit should be set to 1 after the output signal path has been configured, and before the DC Offset cancellation is scheduled This bit should be set with at least 20us delay after HP1L_ENA.
	4	HP1L_ENA	0	Enables HP1L input stage 0 = Disabled 1 = Enabled For pop-free operation, this bit should be set as the first stage of the HP1L Enable sequence.
	3	HP1R_RMV_SHORT	0	Removes HP1R short 0 = HP1R short enabled 1 = HP1R short removed For pop-free operation, this bit should be set to 1 as the final step in the HP1R Enable sequence.
	2	HP1R_ENA_OUTP	0	Enables HP1R output stage 0 = Disabled 1 = Enabled For pop-free operation, this bit should be set to 1 after the DC offset cancellation has been performed.
	1	HP1R_ENA_DLY	0	Enables HP1R intermediate stage 0 = Disabled 1 = Enabled For pop-free operation, this bit should be set to 1 after the output signal path has been configured, and before the DC Offset cancellation is scheduled This bit should be set with at least 20us delay after HP1R_ENA.
	0	HP1R_ENA	0	Enables HP1R input stage 0 = Disabled 1 = Enabled For pop-free operation, this bit should be set as the first stage of the HP1R Enable sequence.

Table 77 Headphone Output Signal Paths Control

HEADPHONE MIXER CONTROL

The two headphone mixers - HPMIXL and HPMIXR – can each have any combination of the six available input paths enabled as described in Table 78 (left headphone mixers) and Table 79 (right headphone mixers). The six input signal paths are two from the DACs (DACL and DACR), two from the input mixers (MIXINL and MIXINR) and two bypass paths direct from the IN4 input pins (IN4L and IN4R). The headphone mixers are muted by default.

The two signal paths from the left and right DACs to each of the two headphone mixers HPMIXL and HPMIXR are enabled using the register bits DACL_TO_HPMIXL, DACL_TO_HPMIXR, DACR_TO_HPMIXL and DACR_TO_HPMIXR. There is no selectable gain associated with these mixer paths.

The two DAC output signals can also be configured to bypass the headphone mixers using the HPMIXL_TO_HPOUTL_PGA and HPMIXR_TO_HPOUTR_PGA register bits. Note that the DAC output signals bypass the mixers by default.

The direct signal paths from each of the input mixers MIXINL and MIXINR to each of the headphone mixers HPMIXL and HPMIXR are enabled using the MIXINL_TO_HPMIXL, MIXINL_TO_HPMIXR, MIXINR_TO_HPMIXL and MIXINR_TO_HPMIXR register bits. A selectable -6dB control is available on each of these paths to help avoid signal clipping.

The direct signal paths from the IN4L and IN4R input pins to the headphone mixers HPMIXL and HPMIXR are enabled using the IN4L_TO_HPMIXL, IN4L_TO_HPMIXR, IN4R_TO_HPMIXL, and IN4R_TO_HPMIXR register bits. Each input signal path from IN4 also has an associated PGA with a gain range from -15dB to +6dB.

REGISTER ADDRESS	BIT	LABEL	DEFAULT	DESCRIPTION
R100 (64h) Headphone Mixer (1)	7	HPMIXL_TO_HP OUTL_PGA	0	Left Headphone PGA Path Select 0 = DACL Output 1 = HPMIXL Output
	5	DACL_TO_HPMI XL	0	Left DAC to Left Headphone Mixer select 0 = Disabled 1 = Enabled
	4	DACR_TO_HPMI XL	0	Right DAC to Left Headphone Mixer select 0 = Disabled 1 = Enabled
	3	MIXINL_TO_HPM IXL	0	Left Input Mixer to Left Headphone Mixer select 0 = Disabled 1 = Enabled
	2	MIXINR_TO_HP MIXL	0	Right Input Mixer to Left Headphone Mixer select 0 = Disabled 1 = Enabled
	1	IN4L_TO_HPMIX L	0	Input IN4L to Left Headphone Mixer select 0 = Disabled 1 = Enabled
	0	IN4R_TO_HPMIX L	0	Input IN4R to Left Headphone Mixer select 0 = Disabled 1 = Enabled
R102 (66h) Headphone Mixer (3)	8	HPMIXL_MUTE	1	Left Headphone Mixer Mute 0 = Unmuted 1 = Muted
	7	MIXINL_HPMIXL_ VOL	0	Left Input Mixer to Left Headphone Mixer volume 0 = 0dB 1 = -6dB

REGISTER ADDRESS	BIT	LABEL	DEFAULT	DESCRIPTION
	6	MIXINR_HPMIXL_VOL	0	Right Input Mixer to Left Headphone Mixer volume 0 = 0dB 1 = -6dB
	5:3	IN4L_HPMIXL_VOL	111	Input IN4L to Left Headphone Mixer Volume control 000 = -15dB 001 = -12dB 010 = -9dB 011 = -6dB 100 = -3dB 101 = 0dB 110 = +3dB 111 = +6dB
	2:0	IN4R_HPMIXL_VOL	111	Input IN4R to Left Headphone Mixer Volume control 000 = -15dB 001 = -12dB 010 = -9dB 011 = -6dB 100 = -3dB 101 = 0dB 110 = +3dB 111 = +6dB

Table 78 Left Headphone Mixer Control

REGISTER ADDRESS	BIT	LABEL	DEFAULT	DESCRIPTION
R101 (65h) Headphone Mixer (2)	7	HPMIXR_TO_HP_OUTR_PGA	0	Right Headphone PGA Path Select 0 = DACR Output 1 = HPMIXR Output
	5	DACL_TO_HP MIXR	0	Left DAC to Right Headphone Mixer select 0 = Disabled 1 = Enabled
	4	DACR_TO_HP MIXR	0	Right DAC to Right Headphone Mixer select 0 = Disabled 1 = Enabled
	3	MIXINL_TO_HP MIXR	0	Left Input Mixer to Right Headphone Mixer select 0 = Disabled 1 = Enabled
	2	MIXINR_TO_HP MIXR	0	Right Input Mixer to Right Headphone Mixer select 0 = Disabled 1 = Enabled
	1	IN4L_TO_HP MIXR	0	Input IN4L to Right Headphone Mixer select 0 = Disabled 1 = Enabled
	0	IN4R_TO_HP MIXR	0	Input IN4R to Right Headphone Mixer select 0 = Disabled 1 = Enabled

REGISTER ADDRESS	BIT	LABEL	DEFAULT	DESCRIPTION
R103 (67h) Headphone Mixer (4)	8	HPMIXR_MUTE	1	Right Headphone Mixer Mute 0 = Unmuted 1 = Muted
	7	MIXINL_HPMIXR_VOL	0	Left Input Mixer to Right Headphone Mixer volume 0 = 0dB 1 = -6dB
	6	MIXINR_HPMIXR_VOL	0	Right Input Mixer to Right Headphone Mixer volume 0 = 0dB 1 = -6dB
	5:3	IN4L_HPMIXR_VOL	111	Input IN4L to Right Headphone Mixer Volume control 000 = -15dB 001 = -12dB 010 = -9dB 011 = -6dB 100 = -3dB 101 = 0dB 110 = +3dB 111 = +6dB
	2:0	IN4R_HPMIXR_VOL	111	Input IN4R to Right Headphone Mixer Volume control 000 = -15dB 001 = -12dB 010 = -9dB 011 = -6dB 100 = -3dB 101 = 0dB 110 = +3dB 111 = +6dB

Table 79 Right Headphone Mixer Control

HEADPHONE OUTPUT PGA CONTROL

There are four headphone output PGAs – two primary (HPOUTL and HPOUTR), and two secondary (HP1L, HP1R). The headphone outputs are each controlled by a primary PGA and a secondary PGA in series.

The HPOUTL and HPOUTR PGAs give a high degree of control from -68dB to +6dB in 1dB steps. A detailed table of all HPOUTL and HPOUTR gain settings is shown in Table 73. Secondary PGAs for HPOUTL and HPOUTR provide control from -7dB to 0dB in 1dB steps on each channel. See Figure 33 for a representation of this layout.

The HPOUT PGAs are controlled using the HPOUTL_VOL and HPOUTR_VOL registers, providing fine volume control to HPOUTL and HPOUTR.

To prevent "zipper noise", a zero-cross function is provided on the HPOUTL and HPOUTR output PGAs. When this feature is enabled, volume updates will not take place until a zero-crossing is detected. In the case of a long period without zero-crossings, a timeout function is provided. When the zero-cross function is enabled, the volume will update after the timeout period if no earlier zero-cross has occurred. The timeout clock is enabled using TOCLK_ENA; the timeout period is set by TOCLK_DIV. See "Clocking and Sample Rates" for more information on these fields.

It is recommended that only HPOUTL PGA and HPOUTR PGA are modified while the output signal path is active as these are the only Headphone PGAs with the zero-cross function. It is recommended that the other gain controls on the signal paths should not be modified while the signal path is active.

The left and right channels can also be attenuated independently using the HP1L_VOL and HP1R_VOL registers. Note that there is no zero-cross function associated with these registers.

The headphone output signal can be muted using the HPOUTL_PGA_MUTE and HPOUTR_PGA_MUTE registers. The headphone outputs are un-muted by default.

The HPOUT_VU bits control the loading of the Headphone Output PGA volume data and the PGA mute functions. When HPOUT_VU is set to 0, the volume control data will be loaded into the respective control register, but will not actually change the gain setting. The left and right Headphone Output PGA volume settings are both updated when a 1 is written to any of the HPOUT_VU bits. Similarly, the HPOUTL_PGA_MUTE and HPOUTR_PGA_MUTE settings are only effective when a 1 is written to either HPOUT_VU bit. This makes it possible to update the gain of the left and right output paths simultaneously.

Note that the HP1L_VOL and HP1R_VOL registers are effective immediately when updated; the HPOUT_VU bits have no control over the Secondary PGA volume registers. For best performance, the Secondary PGA volume registers should be set to 000b (-7dB). See "Reference Voltages and Bias Control" for further details of the High Performance headphone playback configuration.

REGISTER ADDRESS	BIT	LABEL	DEFAULT	DESCRIPTION
R2 (2h) HPOUTL volume	8	HPOUT_VU	N/A	Headphone Output PGA Volume and Mute Update. Writing 1 to this bit will cause the HPOUTL and HPOUTR volume and mute settings to be updated simultaneously.
	7	HPOUTL_ZC	0	Left Headphone Output PGA Zero Cross Enable 0 = Zero cross disabled 1 = Zero cross enabled
	6:0	HPOUTL_VOL [6:0]	0 (Mute)	Left Headphone Output PGA Volume 000_0000 to 010_1111 = Mute 011_0000 to 011_0101 = -68dB 011_0110 = -67dB ...in 1dB steps 111_1001 = 0dB ... 111_1111 = +6dB (See Table 73 for full volume control range)

REGISTER ADDRESS	BIT	LABEL	DEFAULT	DESCRIPTION
R3 (2h) HPOUTR volume	8	HPOUT_VU	N/A	Headphone Output PGA Volume and Mute Update Writing 1 to this bit will cause the HPOUTL and HPOUTR volume and mute settings to be updated simultaneously.
	7	HPOUTR_ZC	0	Right Headphone Output PGA Zero Cross Enable 0 = Zero cross disabled 1 = Zero cross enabled
	6:0	HPOUTR_VOL [6:0]	0 (Mute)	Right Headphone Output PGA Volume 000_0000 to 010_1111 = Mute 011_0000 to 011_0101 = -68dB 011_0110 = -67dB ...in 1dB steps 111_1001 = 0dB ... 111_1111 = +6dB (See Table 73 for full volume control range)
R26 (1A) Pwr Mgmt (2)	1	HPOUTL_PGA_MUTE	0	HPOUTL_VOL (Left Headphone Output PGA) Mute 0 = Un-mute 1 = Mute
	0	HPOUTR_PGA_MUTE	0	HPOUTR_VOL (Right Headphone Output PGA) Mute 0 = Un-mute 1 = Mute
R71 (47h) Analogue HP 2	8:6	HP1L_VOL [2:0]	111	Headphone 1 Left Secondary PGA volume. 000 = -7dB 001 = -6dB 010 = -5dB 011 = -4dB 100 = -3dB 101 = -2dB 110 = -1dB 111 = 0dB (default)
	5:3	HP1R_VOL [2:0]	111	Headphone 1 Right Secondary PGA volume. 000 = -7dB 001 = -6dB 010 = -5dB 011 = -4dB 100 = -3dB 101 = -2dB 110 = -1dB 111 = 0dB (default)

Table 80 Headphone Output PGA (HPOUTL_VOL, HPOUTR_VOL, HP1L_VOL, HP1R_VOL) Control

HEADPHONE OUTPUT CONFIGURATIONS

The headphone output driver is capable of driving up to 25mW into a 16Ω or 32Ω load such as a stereo headset or headphones. The outputs are ground-referenced, eliminating any requirement for AC coupling capacitors. This is achieved by having separate positive and negative supply rails powered by an on-chip charge pump. A DC Servo circuit removes any DC offset from the headphone outputs, suppressing 'pop' noise and minimising power consumption. The Charge Pump and DC Servo are described separately (see "Charge Pump" and "DC Servo" respectively).

It is recommended to connect a zobel network to the headphone output pins HPOUTL and HPOUTR for best audio performance in all applications. The components of the zobel network have the effect of dampening high frequency oscillations or instabilities that can arise outside the audio band under certain conditions. Possible sources of these instabilities include the inductive load of a headphone coil or an active load in the form of an external line amplifier. The capacitance of lengthy cables or PCB tracks can also lead to amplifier instability. The zobel network should comprise of a 20Ω resistor and 100nF capacitor in series with each other, as illustrated in Figure 36.

Note that the zobel network may be unnecessary in some applications; it depends upon the characteristics of the connected load. It is recommended to include these components for best audio quality and amplifier stability in all cases.

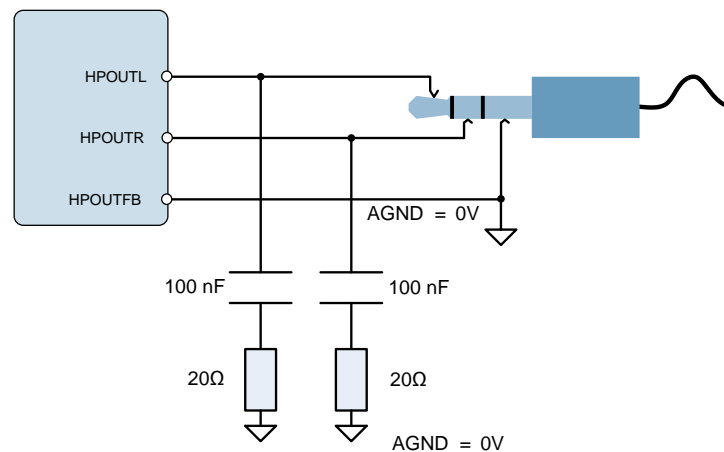

Figure 36 Zobel Network Components for HPOUTL and HPOUTR

The headphone output incorporates a common mode, or ground loop, feedback path which provides rejection of system-related ground noise. The return path is via HPOUTFB. This pin must be connected to ground for normal operation of the headphone output. No register configuration is required.

CHARGE PUMP

The WM8962B incorporates a dual-mode Charge Pump which generates the supply rails for the headphone output drivers, HPOUTL and HPOUTR. The Charge Pump has a single supply input, CPVDD, and generates split rails CPVOUTP and CPVOUTN according to the selected mode of operation. The Charge Pump connections are illustrated in Figure 37 (see “Electrical Characteristics” for external component values). An input decoupling capacitor may also be required at CPVDD, depending upon the system configuration.

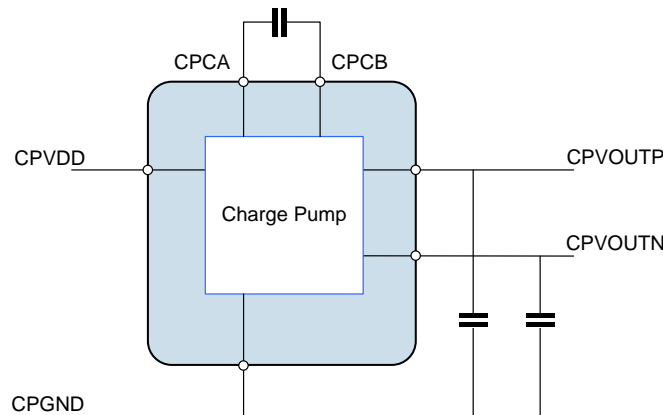

Figure 37 Charge Pump External Connections

The Charge Pump is enabled by setting the CP_ENA bit. When enabled, the charge pump adjusts the output voltages (CPVOUTP and CPVOUTN) as well as the switching frequency in order to optimise the power consumption according to the operating conditions. This can take two forms, which are selected using the CP_DYN_PWR register bit.

- Register control (CP_DYN_PWR = 0)
- Dynamic control (CP_DYN_PWR = 1)

Under Register control, the HPOUTL_VOL and HPOUTR_VOL register settings are used to control the charge pump mode of operation.

Under Dynamic control, the audio signal level in the DAC is also used to control the charge pump mode of operation. This is the Wolfson ‘Class W’ mode, which allows the power consumption to be optimised in real time.

When selecting Register control (CP_DYN_PWR = 0), a ‘1’ must be written to the HPOUT_VU bit to complete the mode change. HPOUT_VU is defined in the “Headphone Output Paths” section (Table 80).

Note that, when selecting Dynamic control (CP_DYN_PWR = 1), the Charge Pump mode change is implemented immediately when CP_DYN_PWR is updated.

When digital sidetone is used (see “Digital Mixing”), it is recommended that the Charge Pump operates in Register Control mode only (CP_DYN_PWR = 0). This is because the Dynamic Control mode (Class W) does not measure the sidetone signal level and hence the Charge Pump configuration cannot be optimised for all signal conditions when digital sidetone is enabled; this could lead to signal clipping.

When Virtual Surround Sound (VSS), HD Bass or DAC ReTune is used (see “DAC Signal Path Enhancements”), it is recommended that the Charge Pump operates in Register Control mode only (CP_DYN_PWR = 0). This is because the Dynamic Control mode (Class W) does not measure the DSP Signal Enhancements level and hence the Charge Pump cannot be optimised for all signal conditions when VSS, HD Bass or DAC ReTune is enabled; this could lead to signal clipping.

Under the recommended usage conditions of the WM8962B, the Charge Pump will be enabled by running the default headphone Start-Up sequence as described in the “Control Write Sequencer” section. (Similarly, it will be disabled by running the Shut-Down sequence.) In these cases, the user does not need to write to the CP_ENA bit. The Charge Pump operating mode defaults to Register control; Dynamic control may be selected by setting the CP_DYN_PWR register bit, if appropriate.

The SYSCLK signal must be present for the charge pump to function. The clock division from MCLK (or the internal oscillator) is handled transparently by the WM8962B without user intervention, as long as SYSCLK and sample rates are set correctly (see “Clocking and Sample Rates” section). The clock divider ratio depends on the SAMPLE_RATE[2:0] and MCLK_RATE[3:0] register settings.

The Charge Pump control fields are described in Table 81.

REGISTER ADDRESS	BIT	LABEL	DEFAULT	DESCRIPTION
R72 (48h) Charge Pump 1	0	CP_ENA	0	Enable charge-pump digits 0 = disable 1 = enable
R82 (52h) Charge Pump B	0	CP_DYN_PWR	0	Enable dynamic charge pump power control 0 = Charge pump controlled by volume register settings (Class G) 1 = Charge pump controlled by real-time audio level (Class W) Class W is recommended for lowest power consumption When selecting CP_DYN_PWR=0, a '1' must be written to the HPOUT_VU bit (Register R2 or R3) to complete the mode change.

Table 81 Charge Pump Control

DC SERVO

The WM8962B provides four DC servo circuits - two on the headphone outputs HPOUTL and HPOUTR, and two on the analogue input paths INL and INR. The DC servo circuits remove offset from these signal paths.

Removal of DC offset on the headphone outputs is important because any deviation from GND at the output pin will cause current to flow through the load under quiescent conditions, resulting in increased power consumption. Additionally, the presence of DC offsets can result in audible pops and clicks at power up and power down. The DC servo ensures that the DC level on the headphone outputs is within 1.2mV of GND.

Removal of DC offset on the input paths is important because any deviation from VMID at the ADC input will prevent correct operation of the zero-cross detection and may also restrict the maximum analogue input signal level. (Zero-cross detection is available for PGA volume updates, including when the PGA is controlled by the ALC control.)

The recommended usage of the DC Servo is initialised by running the default Start-Up sequence as described in the “Control Write Sequencer” section. The default Start-Up sequence executes a series of DC offset corrections, after which the measured offset correction is maintained on the headphone output channels.

Updates to the DC Servo correction can also be scheduled using register writes, including during audio playback. The relevant control fields are described in the following paragraphs and are defined in Table 82.

DC SERVO ENABLE AND START-UP

The DC Servo circuits are enabled on HPOUTL and HPOUTR by setting HP1L_DCS_ENA and HP1R_DCS_ENA respectively. Equivalent registers are provided for the analogue input paths INL and INR. When the DC Servo is enabled, the DC offset correction can be commanded in different ways, as described below.

Writing a logic 1 to HP1L_DCS_STARTUP initiates a series of DC offset measurements and applies the necessary correction to the HPOUTL output. On completion, the output will be within 1.2mV of AGND. This is the DC Servo mode selected by the default Start-Up sequence. Completion of this DC offset correction is indicated by the DCS_STARTUP_DONE_HP1L, as described in Table 82.

The DC Servo Start-Up function is supported on all four DC Servo channels; individual register control is provided for each channel. The DC Servo Start-Up can be commanded on multiple channels simultaneously if required. Typically, this operation takes 24ms per channel.

The DC Servo control fields associated with start-up operation are described in Table 82. For Headphone output DC offset correction, it is important to note that the DC Servo Start-Up mode should be commanded as part of a control sequence which includes muting and shorting of the headphone outputs; a suitable sequence is defined in the default Start-Up sequence (see “Control Write Sequencer”). See also the “Headphone Output Paths” section for the details of the recommended Headphone Enable/Disable sequence.

Note that, once the DC offset correction has been performed, the measured offset will be maintained in memory, even when the associated signal path is disabled. This means that, if required, the DC offset correction can be performed on all channels during start-up, and each channel may then be disabled or enabled when required, without having to re-schedule the DC offset correction.

The DC Servo circuit uses the Charge Pump power supply. The Charge Pump must be enabled by setting the CP_ENA register bit and ensuring that a suitable clock (eg. MCLK) is present. If these conditions are not met, then DC offset correction cannot be performed. See “Charge Pump” and “Clocking and Sample Rates” for details of the associated controls.

REGISTER ADDRESS	BIT	LABEL	DEFAULT	DESCRIPTION
R60 (3Ch) DC Servo 0	7	INL_DCS_ENA	0	DC Servo enable for Left input signal path 0 = Disabled 1 = Enabled
	6	INL_DCS_STARTUP	0	Writing 1 to this bit selects Start-Up DC Servo mode for Left input signal path
	3	INR_DCS_ENA	0	DC Servo enable for Right input signal path 0 = Disabled 1 = Enabled
	2	INR_DCS_STARTUP	0	Writing 1 to this bit selects Start-Up DC Servo mode for Right input signal path
R61 (3Dh) DC Servo 1	7	HP1L_DCS_ENA	0	DC Servo enable for HPOUTL 0 = Disabled 1 = Enabled
	6	HP1L_DCS_STARTUP	0	Writing 1 to this bit selects Start-Up DC Servo mode for HPOUTL
	3	HP1R_DCS_ENA	0	DC Servo enable for HPOUTR 0 = Disabled 1 = Enabled
	2	HP1R_DCS_STARTUP	0	Writing 1 to this bit selects Start-Up DC Servo mode for HPOUTR
R66 (42h) DC Servo 6	10	DCS_STARTUP_DONE_IN1L	0	DC Servo Start-Up Status (Left Input) 0 = Not complete 1 = Complete
	9	DCS_STARTUP_DONE_IN1R	0	DC Servo Start-Up Status (Right Input) 0 = Not complete 1 = Complete
	8	DCS_STARTUP_DONE_HP1L	0	DC Servo Start-Up Status (HPOUTL) 0 = Not complete 1 = Complete
	7	DCS_STARTUP_DONE_HP1R	0	DC Servo Start-Up Status (HPOUTR) 0 = Not complete 1 = Complete

Table 82 DC Servo Enable and Start-Up Modes

DC SERVO ACTIVE MODES

The DC Servo Start-Up mode described above is suitable for initialising the DC offset correction circuit on the input or output signal paths as part of a controlled start-up sequence which is executed before the signal path is fully enabled. The WM8962B also supports DC offset measurement and correction on the HP output paths whilst the signal path is active; this may be of benefit following a large change in signal gain, which can lead to a change in DC offset level.

Writing a logic 1 to HP1L_DCS_SYNC initiates a series of DC offset measurements and applies the necessary correction to the HPOUTL output. Writing a logic 1 to HP1R_DCS_SYNC initiates a series of DC offset measurements and applies the necessary correction to the HPOUTR output.

The number of DC Servo operations performed is determined by HP1_DCS_SYNC_STEP. A maximum of 127 operations may be selected, though a much lower value will be sufficient in most applications. The DC Servo uses filtering to measure the DC offset in the presence of any audio that may be present; this requires a longer time to perform the correction process than in the Start-Up mode, and means that the DC Servo may be operating for several seconds after the process was initiated.

The DC Servo Sync mode described above is supported on the HPOUT DC Servo channels; individual register control is provided for each channel. It is recommended that the DC Servo Sync mode is scheduled whenever a large change in signal gain (eg. >6dB) is applied in the output signal path. Note that the DC Servo Sync mode is not required on the input signal paths as the DC offset in these paths does not change with gain, and only the Start-Up correction is necessary.

The DC Servo control fields associated with Sync mode (suitable for use on a signal path that is in active use) are described in Table 83.

REGISTER ADDRESS	BIT	LABEL	DEFAULT	DESCRIPTION
R61 (3Dh) DC Servo 1	4	HP1L_DCS_SYNC	0	Writing 1 to this bit selects a series of DC offset corrections for HPOUTL
	0	HP1R_DCS_SYNC	0	Writing 1 to this bit selects a series of DC offset corrections for HPOUTR
R64 (40h) DC Servo 4	13:7	HP1_DCS_SYNC_STEP [6:0]	10h	Number of DC Servo updates to perform in a series event (HPOUTL and HPOUTR) 00h to 0Fh = Reserved 10h = 16 (default) 11h = 17 ... 7Fh = 127

Table 83 DC Servo Active Modes

REFERENCE VOLTAGES AND BIAS CONTROL

This section describes the analogue reference voltage and bias current controls. It also describes the VMID soft-start circuit for pop suppressed start-up and shut-down. Note that, under the recommended usage conditions of the WM8962B, these features will be configured by running the default Start-Up and Shut-Down sequences as described in the “Control Write Sequencer” section. In these cases, the user does not need to set these register fields directly.

ANALOGUE REFERENCE AND MASTER BIAS

The analogue circuits in the WM8962B require a mid-rail analogue reference voltage, VMID. This reference is generated from AVDD via a programmable resistor chain. The VMID reference generator requires a bias current, which is enabled by STARTUP_BIAS_ENA. Together with the external VMID decoupling capacitor, the programmable VMID resistor chain results in a slow, normal or fast charging characteristic on VMID. This is controlled by the VMID_SEL register, and can be used to optimise the reference for normal operation, low power standby or for fast start-up as described in Table 84. For normal operation, the VMID_SEL field should be set to 01.

A soft-start circuit is provided in order to control the switch-on of the VMID reference; this is enabled by setting VMID_RAMP. When the soft-start circuit is enabled prior to enabling VMID_SEL, the VMID reference rises smoothly, without any step change that could otherwise occur.

The analogue circuits in the WM8962B require a bias current. The normal bias current is enabled by setting BIAS_ENA. Note that the normal bias current source requires VMID to be enabled also.

The analogue inputs to the WM8962B are biased to VMID in normal operation. In order to avoid audible pops caused by a disabled signal path dropping to AGND, the WM8962B can maintain these connections at VMID when the relevant input stage is disabled. This is achieved by connecting a buffered VMID reference to the input or output. The buffered VMID reference is enabled by setting VMID_BUF_ENA.

REGISTER ADDRESS	BIT	LABEL	DEFAULT	DESCRIPTION
R25 (19h) Pwr Mgmt (1)	8:7	VMID_SEL [1:0]	00	VMID Divider Enable and Select 00 = VMID disabled (for OFF mode) 01 = 2 x 50k divider (for normal operation) 10 = 2 x 250k divider (for low power standby) 11 = 2 x 5k divider (for fast start-up)
	6	BIAS_ENA	0	Enables the Normal bias current generator (for all analogue functions) 0 = Disabled 1 = Enabled
R28 (1Ch) Anti-pop	4	STARTUP_BIAS_ENA	0	Enables the Start-Up bias current generator 0 = Disabled 1 = Enabled
	3	VMID_BUF_ENA	0	VMID Buffer Enable 0 = Disabled 1 = Enabled
	2	VMID_RAMP	0	Enables VMID soft ramp-up 0 = Disabled 1 = Enabled

Table 84 Reference Voltages and Master Bias Enable

INPUT SIGNAL PATH BIAS CONTROL SETTINGS

All the analogue circuits of the WM8962B require a bias current. The bias current in the input signal path circuits can be controlled using the register bits described in Table 85.

When adjusting the bias settings, there is always a trade-off between performance and power. Selecting a lower bias can be used to reduce power consumption, but may have a marginal impact on audio performance in some usage modes. Selecting a higher bias offers a performance improvement, but also an increase in power consumption.

REGISTER ADDRESS	BIT	LABEL	DEFAULT	DESCRIPTION
R23 (17h) Additional Control (1)	5	ADC_HP	0	ADC Oversampling Ratio 0 = Low Power (typically 64 x fs) 1 = High Performance (typically 128 x fs)
R35 (23h) Input bias control	5:3	MIXIN_BIAS	000	Input Boost-Mixer Bias Control 000 = x 2.0 (default) 001 = Reserved 010 = Reserved 011 = x 1.0 100 = x 0.67 101 to 111 = Reserved
	2:0	INPGA_BIAS	100	Input PGA Bias Control 000 = x 2.0 001 = Reserved 010 = Reserved 011 = Reserved 100 = x 0.67 (default) 101 to 111 = Reserved

Table 85 Input Signal Path Bias Control Settings

It is recommended that the input signal path bias control settings are selected only from the supported combinations listed in Table 86.

DESCRIPTION	ADC_HP	MIXIN_BIAS	INPGA_BIAS	NOTES
Option 1	0	100	100	Lowest power consumption
Option 2	0	011	100	
Option 3 (default)	0	000	100	
Option 4	1	000	000	Highest performance

Table 86 Recommended Bias Control Settings (Input Signal Path)

OUTPUT SIGNAL PATH BIAS CONTROL SETTINGS

All the analogue circuits of the WM8962B require a bias current. The bias current in the output signal path circuits can be controlled using the register bits described in Table 87.

When adjusting the bias settings, there is always a trade-off between performance and power. Selecting a lower bias can be used to reduce power consumption, but may have a marginal impact on audio performance in some usage modes. Selecting a higher bias offers a performance improvement, but also an increase in power consumption.

REGISTER ADDRESS	BIT	LABEL	DEFAULT	DESCRIPTION
R6 (06h) ADC & DAC Control 2	0	DAC_HP	0	DAC Oversampling Ratio 0 = Low Power (typically 64 x fs) 1 = High Performance (typically 128 x fs)
R68 (44h) Analogue PGA Bias	2:0	HP_PGAS_BIAS [2:0]	011	Headphone PGA Boost Bias 000 = x 2.0 001 = Reserved 010 = Reserved 011 = x 1.0 (default) 100 to 111 = Reserved
R71 (47h) Analogue HP 2	2:0	HP_BIAS_BOOST [2:0]	011	Headphone Driver Boost Bias 000 = x 2.0 001 = Reserved 010 = Reserved 011 = x 1.0 (default) 100 to 111 = Reserved

Table 87 Output Signal Path Bias Control Settings

It is recommended that the output signal path bias control settings are selected only from the supported combinations listed in Table 88.

Note that, for the specified performance in 'High Performance' mode, the headphone output secondary PGAs must be set to -7dB attenuation. See "Headphone Output Paths" for details of the associated registers.

DESCRIPTION	DAC_HP	HP_PGAS_BIAS	HP_BIAS_BOOST	HP1L_VOL, HP1R_VOL
Low Power headphone playback mode	0	011	011	XXX
High Performance headphone playback mode	1	000	000	000

Table 88 Recommended Bias Control Settings (Output Signal Path)

Note that power consumption in the WM8962B can be optimised in real time using the adaptive Charge Pump that provides the supply rails to the headphone driver. The Dynamic control mode of the Charge Pump provides lowest power consumption, and may be selected in Low Power or High Performance headphone playback modes.

Note that there are some operating conditions in which the Dynamic control mode should not be selected; these are described in the "Charge Pump" section.

DIGITAL AUDIO INTERFACE

The digital audio interface is used for inputting DAC data to the WM8962B and outputting ADC data from it. The digital audio interface uses four pins:

- ADCDAT: ADC data output
- DACDAT: DAC data input
- LRCLK: Left/Right data alignment clock
- BCLK: Bit clock, for synchronisation

The clock signals BCLK and LRCLK can be outputs when the WM8962B operates as a master, or inputs when it is a slave (see “Master and Slave Mode Operation”, below).

Four different audio data formats are supported:

- Left justified
- Right justified
- I²S
- DSP mode

All four of these modes are MSB first. They are described in “Audio Data Formats (Normal Mode)” below. Refer to the “Signal Timing Requirements” section for timing information.

Time Division Multiplexing (TDM) is available in all four data format modes. The WM8962B can be programmed to send and receive data in one of two time slots.

PCM operation is supported using the DSP mode.

MASTER AND SLAVE MODE OPERATION

The WM8962B digital audio interface can operate as a master or slave as shown in Figure 38 and Figure 39.

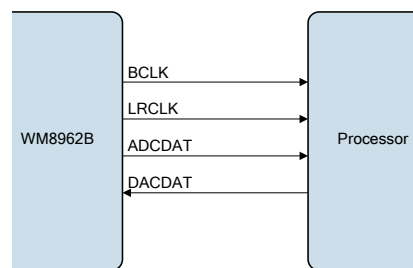

Figure 38 Master Mode

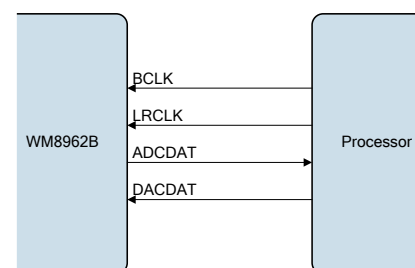

Figure 39 Slave Mode

The Audio Interface output control is illustrated above. The MSTR control register determines whether the WM8962B generates the clock signals. The MSTR register field is defined in Table 89.

REGISTER ADDRESS	BIT	LABEL	DEFAULT	DESCRIPTION
R7 (07h) Audio Interface 0	6	MSTR	0	Audio Interface Mode Select 0 = Slave mode 1 = Master mode

Table 89 Audio Interface Master/Slave Control

OPERATION WITH TDM

Time division multiplexing (TDM) allows multiple devices to transfer data simultaneously on the same bus. The WM8962B ADCs and DACs support TDM in master and slave modes for all data formats and word lengths. TDM is enabled and configured using register bits defined in the "Digital Audio Interface Control" section.

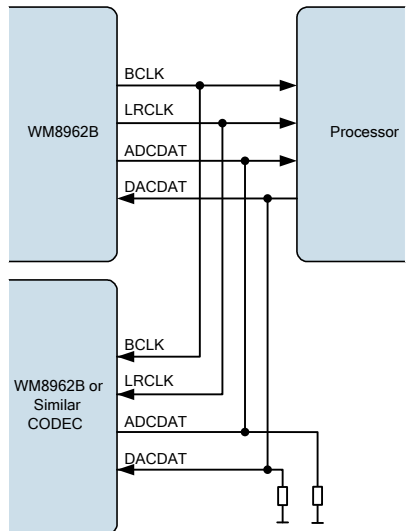

Figure 40 TDM with WM8962B as Master

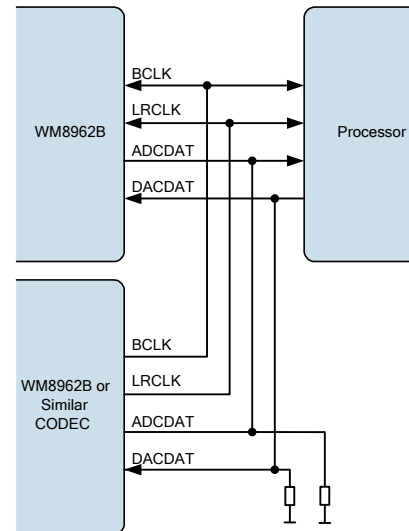

Figure 41 TDM with Other CODEC as Master

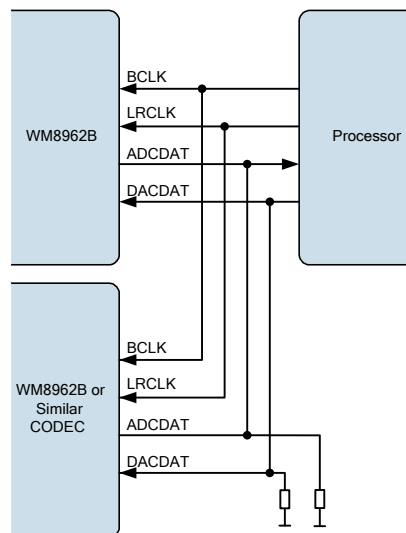

Figure 42 TDM with Processor as Master

Note: The WM8962B is a 24-bit device. If the user operates the WM8962B in 32-bit mode then the 8 LSBs will be ignored on the receiving side and not driven on the transmitting side. It is therefore recommended to add a pull-down resistor, if necessary, to the DACDAT line and the ADCDAT line in TDM mode.

BCLK FREQUENCY

The BCLK frequency is controlled relative to SYSCLK by the BCLK_DIV divider. Internal clock divide and phase control mechanisms ensure that the BCLK and LRCLK edges will occur in a predictable and repeatable position relative to each other and relative to the data for a given combination of DAC/ADC sample rate and BCLK_DIV settings.

BCLK_DIV is defined in the “Digital Audio Interface Control” section. See also “Clocking and Sample Rates” section for more information.

AUDIO DATA FORMATS (NORMAL MODE)

In Right Justified mode, the LSB is available on the last rising edge of BCLK before a LRCLK transition. All other bits are transmitted before (MSB first). Depending on word length, BCLK frequency and sample rate, there may be unused BCLK cycles after each LRCLK transition.

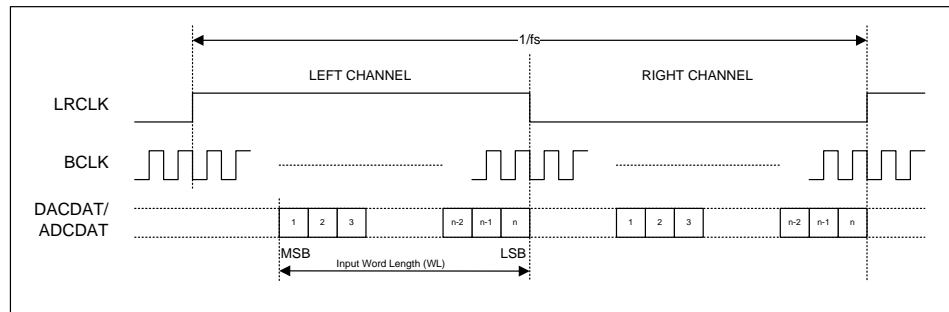

Figure 43 Right Justified Audio Interface (assuming n-bit word length)

In Left Justified mode, the MSB is available on the first rising edge of BCLK following a LRCLK transition. The other bits up to the LSB are then transmitted in order. Depending on word length, BCLK frequency and sample rate, there may be unused BCLK cycles before each LRCLK transition.

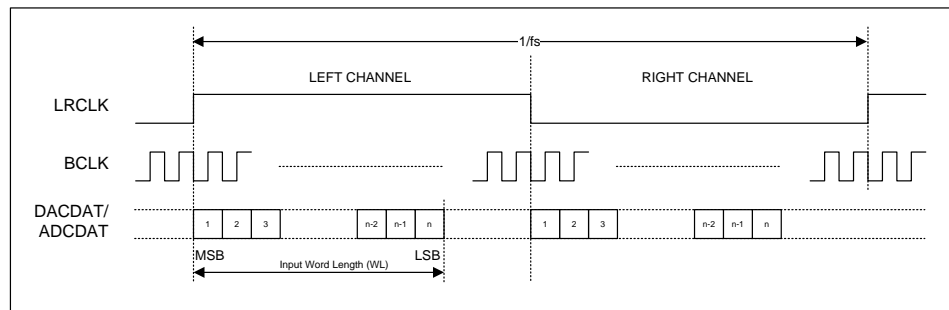

Figure 44 Left Justified Audio Interface (assuming n-bit word length)

In I²S mode, the MSB is available on the second rising edge of BCLK following a LRCLK transition. The other bits up to the LSB are then transmitted in order. Depending on word length, BCLK frequency and sample rate, there may be unused BCLK cycles between the LSB of one sample and the MSB of the next.

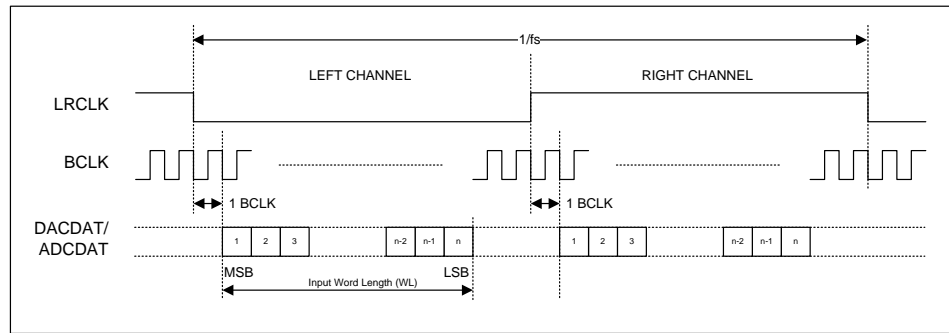

Figure 45 I2S Justified Audio Interface (assuming n-bit word length)

In DSP mode, the left channel MSB is available on either the 1st (mode B) or 2nd (mode A) rising edge of BCLK (selectable by LRCLK_INV) following a rising edge of LRCLK. Right channel data immediately follows left channel data. Depending on word length, BCLK frequency and sample rate, there may be unused BCLK cycles between the LSB of the right channel data and the next sample.

In device master mode, the LRCLK output will resemble the frame pulse shown in Figure 46 and Figure 47. In device slave mode, Figure 48 and Figure 49, it is possible to use any length of frame pulse less than $1/f_s$, providing the falling edge of the frame pulse occurs greater than one BCLK period before the rising edge of the next frame pulse.

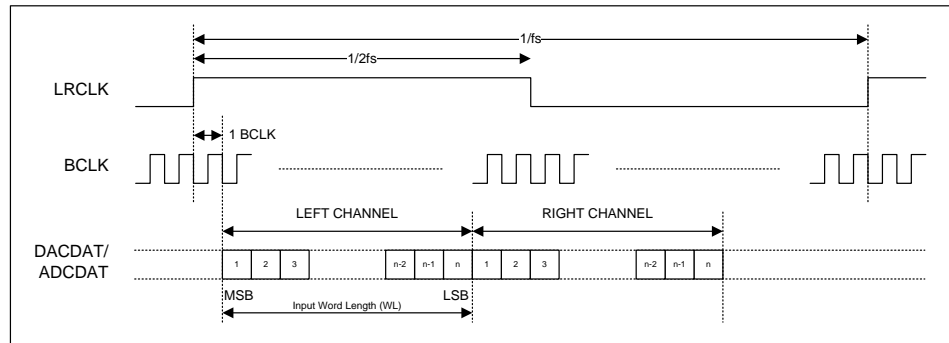

Figure 46 DSP Mode Audio Interface (mode A, LRCLK_INV=0, Master)

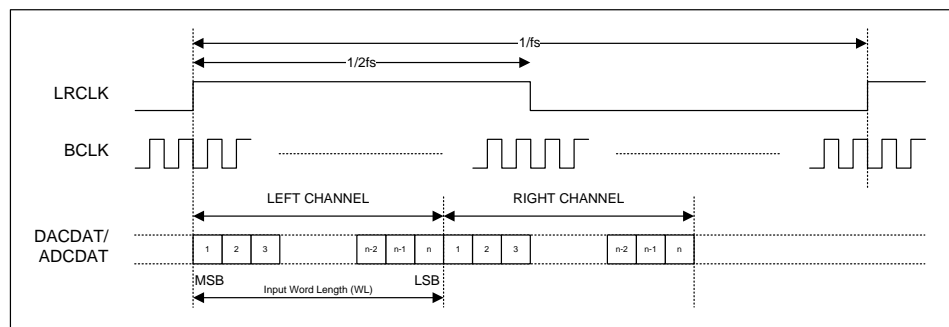

Figure 47 DSP Mode Audio Interface (mode B, LRCLK_INV=1, Master)

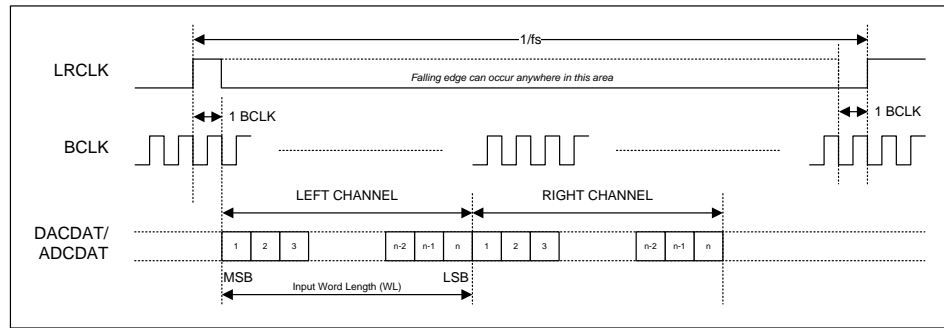

Figure 48 DSP Mode Audio Interface (mode A, LRCLK_INV=0, Slave)

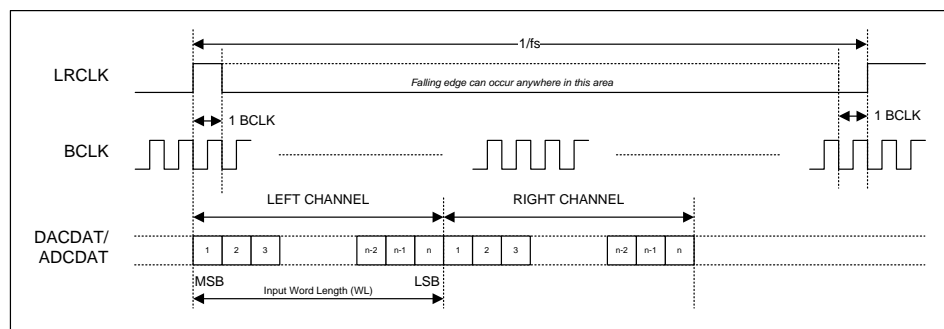

Figure 49 DSP Mode Audio Interface (mode B, LRCLK_INV=1, Slave)

PCM operation is supported in DSP interface mode. WM8962B ADC data that is output on the Left Channel will be read as mono PCM data by the receiving equipment. Mono PCM data received by the WM8962B will be treated as Left Channel data. This data may be routed to the Left/Right DACs as described in the “Digital Mixing” section.

AUDIO DATA FORMATS (TDM MODE)

TDM is supported in master and slave mode and is enabled by register bits AIFADC_TDM_MODE and AIFDAC_TDM_MODE. All audio interface data formats support time division multiplexing (TDM) for ADC and DAC data.

Two time slots are available (Slot 0 and Slot 1), selected by register bits AIFADC_TDM_SLOT and AIFDAC_TDM_SLOT which control time slots for the ADC data and the DAC data.

When TDM is enabled, the ADCDAT pin will be tri-stated immediately before and immediately after data transmission, to allow another ADC device to drive this signal line for the remainder of the sample period. Note that it is important that two ADC devices do not attempt to drive the data pin simultaneously. A short circuit may occur if the transmission time of the two ADC devices overlap with each other. See “Audio Interface Timing” for details of the ADCDAT output relative to BCLK signal. Note that it is possible to ensure a gap exists between transmissions by setting the transmitted word length to a value higher than the actual length of the data. For example, if 32-bit word length is selected where only 24-bit data is available, then the WM8962B interface will tri-state after transmission of the 24-bit data, ensuring a gap after the WM8962B’s TDM slot.

When TDM is enabled, BCLK frequency must be high enough to allow data from both time slots to be transferred. The relative timing of Slot 0 and Slot 1 depends upon the selected data format as shown in Figure 50 to Figure 54.

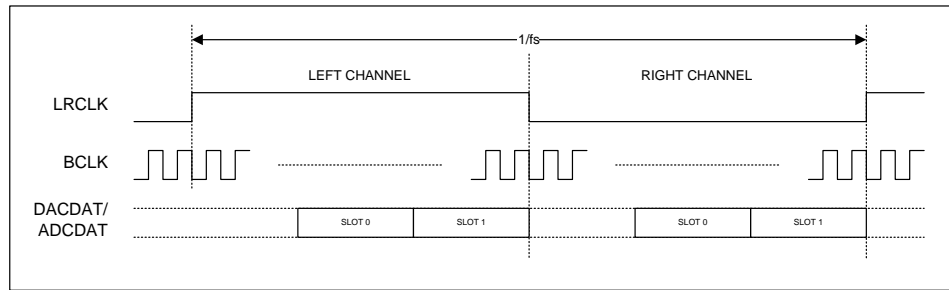
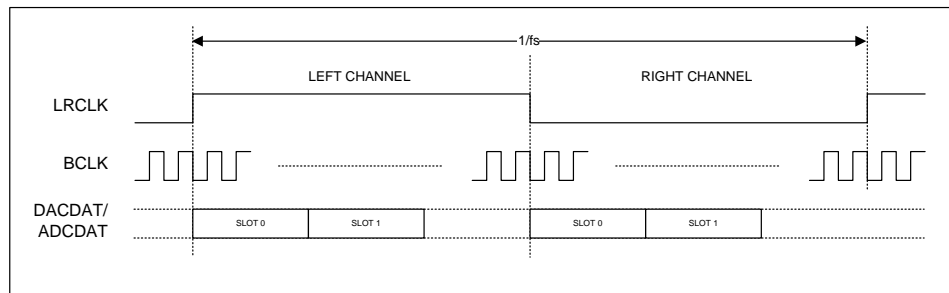
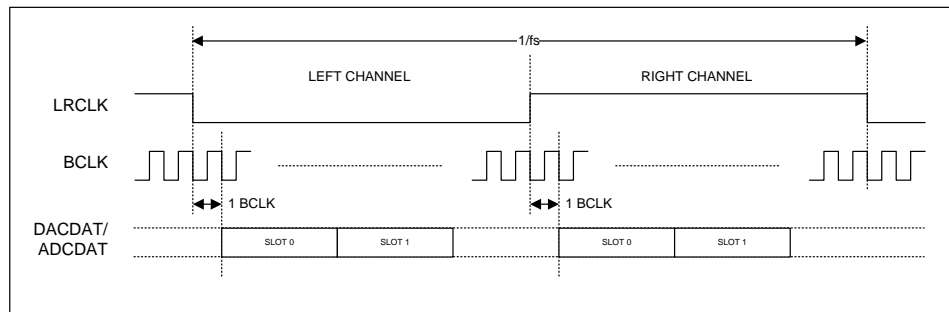
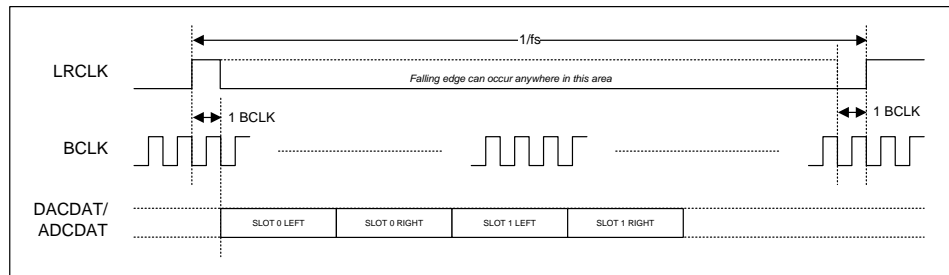
Figure 50 TDM in Right-Justified Mode

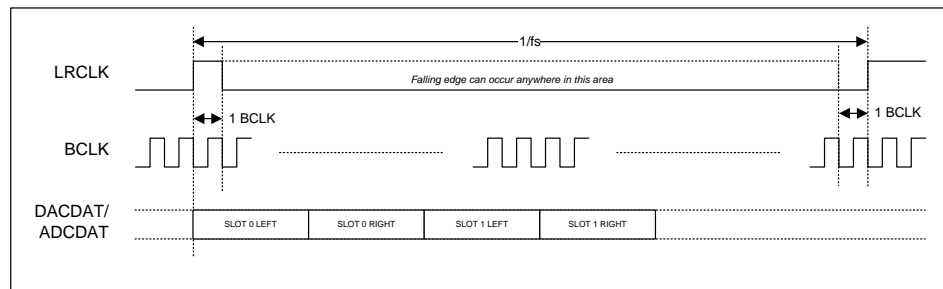
Figure 51 TDM in Left-Justified Mode

Figure 52 TDM in I²S Mode

Figure 53 TDM in DSP Mode A

Figure 54 TDM in DSP Mode B

DIGITAL AUDIO INTERFACE CONTROL

The register bits controlling audio data format, word length, left/right channel data configuration and TDM are summarised in Table 90.

REGISTER ADDRESS	BIT	LABEL	DEFAULT	DESCRIPTION
R5 (05h) ADC & DAC Control 1	6	ADCR_DAT_INV	0	Right ADC Invert 0 = Right ADC output not inverted 1 = Right ADC output inverted
	5	ADCL_DAT_INV	0	Left ADC Invert 0 = Left ADC output not inverted 1 = Left ADC output inverted
R6 (06h) ADC & DAC Control 2	6	DACR_DAT_INV	0	Right DAC Invert 0 = Right DAC input not inverted 1 = Right DAC input inverted
	5	DACL_DAT_INV	0	Left DAC Invert 0 = Left DAC input not inverted 1 = Left DAC input inverted
R7 (07h) Audio Interface 0	12	AIFDAC_TDM_MODE	0	DAC TDM Mode Select 0 = Normal DACDAT operation (1 stereo slot) 1 = TDM enabled on DACDAT (2 stereo slots)
	11	AIFDAC_TDM_SLOT	0	DACDAT TDM Slot Select 0 = DACDAT data input on slot 0 1 = DACDAT data input on slot 1
	10	AIFADC_TDM_MODE	0	ADC TDM Mode Select 0 = Normal ADCDAT operation (1 stereo slot) 1 = TDM enabled on ADCDAT (2 stereo slots)
	9	AIFADC_TDM_SLOT	0	ADCDAT TDM Slot Select 0 = ADCDAT data input on slot 0 1 = ADCDAT data input on slot 1
	8	ADC_LRSWAP	0	Swap left/right ADC data on the interface 0 = Normal 1 = ADCDAT channels swapped
	7	BCLK_INV	0	BCLK Invert 0 = BCLK not inverted 1 = BCLK inverted
	5	DAC_LRSWAP	0	Swap left/right DAC data on the interface 0 = Normal 1 = DACDAT channels swapped

REGISTER ADDRESS	BIT	LABEL	DEFAULT	DESCRIPTION
	4	LRCLK_INV	0	Right, left and I ² S modes – LRCLK polarity 0 = normal LRCLK polarity 1 = invert LRCLK polarity
				DSP Mode – mode A/B select 0 = MSB is available on 2nd BCLK rising edge after LRCLK rising edge (mode A) 1 = MSB is available on 1st BCLK rising edge after LRCLK rising edge (mode B)
	3:2	WL [1:0]	10	Digital Audio Interface Word Length 00 = 16 bits 01 = 20 bits 10 = 24 bits 11 = 32 bits Note - see “Companding” for the selection of 8-bit mode.
	1:0	FMT [1:0]	10	Digital Audio Interface Format 00 = Right justified 01 = Left justified 10 = I ² S Format 11 = DSP Mode

Table 90 Digital Audio Interface Data Control

AUDIO INTERFACE TRI-STATE

Register bit AIF_TRI can be used to tri-state the audio interface pins as described in Table 91. All digital audio interface pins will be tri-stated by this function, regardless of the state of other registers which control these pin configurations.

REGISTER ADDRESS	BIT	LABEL	DEFAULT	DESCRIPTION
R24 (18h) Additional Control (2)	3	AIF_TRI	0	Audio Interface Tristate 0 = Audio interface pins operate normally 1 = ADCDAT is tri-stated; BCLK & LRCLK are set as inputs

Table 91 Digital Audio Interface Tri-State Control

BCLK AND LRCLK CONTROL

The audio interface can be programmed to operate in master mode or slave mode using the MSTR register bit.

In master mode, the BCLK and LRCLK signals are generated by the WM8962B when any of the ADCs or DACs is enabled. In slave mode, the BCLK and LRCLK clock outputs are disabled by default to allow another digital audio interface to drive these pins. Refer to “Clocking and Sample Rates” for specific operating constraints in this configuration.

REGISTER ADDRESS	BIT	LABEL	DEFAULT	DESCRIPTION
R7 (07h) Audio Interface 0	6	MSTR	0	Audio Interface Mode Select 0 = Slave mode 1 = Master mode
R8 (08h) Clocking2	3:0	BCLK_DIV	0100	BCLK Rate 0000 = DSPCLK 0001 = Reserved 0010 = DSPCLK / 2 0011 = DSPCLK / 3 0100 = DSPCLK / 4 (default) 0101 = Reserved 0110 = DSPCLK / 6 0111 = DSPCLK / 8 1000 = Reserved 1001 = DSPCLK / 12 1010 = DSPCLK / 16 1011 = DSPCLK / 24 1100 = Reserved 1101 = DSPCLK / 32 1110 = DSPCLK / 32 1111 = DSPCLK / 32
R14 (0Eh) Audio Interface 2	10:0	AIF_RATE [10:0]	040h	LRCLK Rate LRCLK clock output = BCLK / AIF_RATE Integer (LSB = 1) Valid from 4..2047 Default (040h) = 64 BCLKs per LRCLK

Table 92 Digital Audio Interface Clock Control
COMPANDING

The WM8962B supports A-law and μ -law companding on both transmit (ADC) and receive (DAC) sides as shown in Table 93.

REGISTER ADDRESS	BIT	LABEL	DEFAULT	DESCRIPTION
R9 (09h) Audio Interface 1	4	DAC_COMP	0	DAC Companding Enable 0 = disabled 1 = enabled
	3	DAC_COMPMODE	0	DAC Companding Type 0 = μ -law 1 = A-law
	2	ADC_COMP	0	ADC Companding Enable 0 = disabled 1 = enabled
	1	ADC_COMPMODE	0	ADC Companding Type 0 = μ -law 1 = A-law

Table 93 Companding Control

Companding involves using a piecewise linear approximation of the following equations (as set out by ITU-T G.711 standard) for data compression:

μ -law (where $\mu=255$ for the U.S. and Japan):

$$F(x) = \ln(1 + \mu|x|) / \ln(1 + \mu) \quad -1 \leq x \leq 1$$

A-law (where $A=87.6$ for Europe):

$$F(x) = A|x| / (1 + \ln A) \quad x \leq 1/A$$

$$F(x) = (1 + \ln A|x|) / (1 + \ln A) \quad 1/A \leq x \leq 1$$

The companded data is also inverted as recommended by the G.711 standard (all 8 bits are inverted for μ -law, all even data bits are inverted for A-law). The data will be transmitted as the first 8 MSBs of data.

Companding converts 13 bits (μ -law) or 12 bits (A-law) to 8 bits using non-linear quantization. This provides greater precision for low amplitude signals than for high amplitude signals, resulting in a greater usable dynamic range than 8 bit linear quantization. The companded signal is an 8-bit word comprising sign (1 bit), exponent (3 bits) and mantissa (4 bits).

8-bit mode is selected whenever $DAC_COMP=1$ or $ADC_COMP=1$. The use of 8-bit data allows samples to be passed using as few as 8 BCLK cycles per LRCLK frame. When using DSP mode B, 8-bit data words may be transferred consecutively every 8 BCLK cycles.

8-bit mode (without Companding) may be enabled by setting $DAC_COMPMODE=1$ or $ADC_COMPMODE=1$, when $DAC_COMP=0$ and $ADC_COMP=0$.

BIT7	BIT[6:4]	BIT[3:0]
SIGN	EXPONENT	MANTISSA

Table 94 8-bit Companded Word Composition

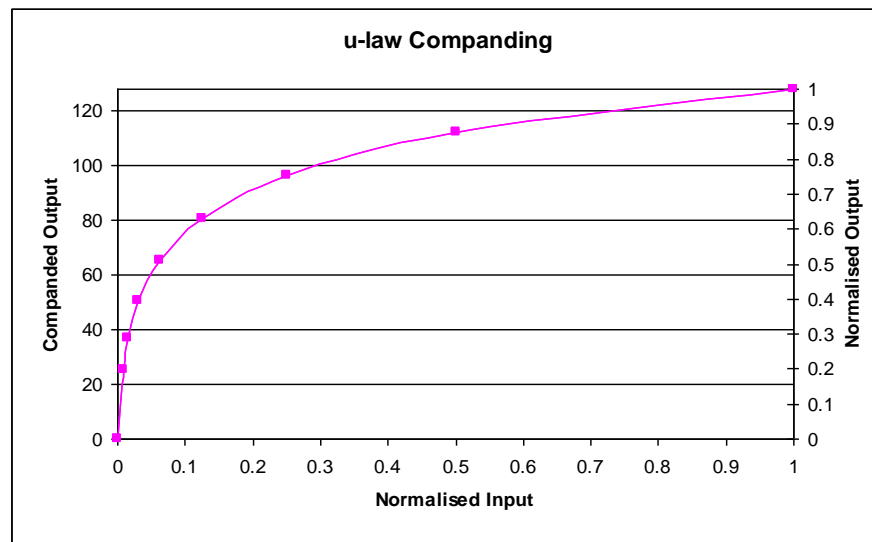

Figure 55 μ -Law Companding

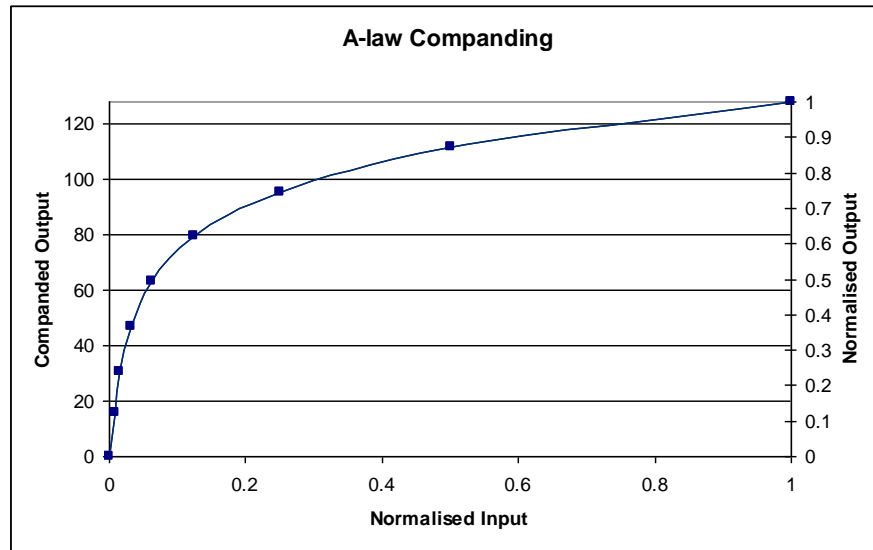

Figure 56 A-Law Companding

LOOPBACK

Setting the LOOPBACK register bit enables digital loopback. When this bit is set, the ADC digital data output is routed to the DAC digital data input path. The digital audio interface input (DACDAT) is not used when LOOPBACK is enabled.

REGISTER ADDRESS	BIT	LABEL	DEFAULT	DESCRIPTION
R9 (09h) Audio Interface (2)	0	LOOPBACK	0	Digital Loopback Function 0 = No loopback 1 = Loopback enabled (ADC data output is directly input to DAC data input).

Table 95 Loopback Control

Note: When the digital sidetone is enabled, ADC data will also be added to DAC digital data input path within the Digital Mixing circuit. This applies regardless of whether LOOPBACK is enabled.

CLOCKING AND SAMPLE RATES

The internal clocks for the WM8962B are all derived from a common internal clock source, SYSCLK. This clock is the reference for the ADCs, DACs, DSP core functions, digital audio interface, Class D switching amplifier, DC servo control and other internal functions.

SYSCLK can either be derived directly from MCLK, or may be generated from the Frequency Locked Loop (FLL) or Phase Locked Loop (PLL). Many commonly-used audio sample rates can be derived directly from typical MCLK frequencies; the FLL and PLL provide additional flexibility for a wide range of reference frequencies. To avoid audible glitches, all clock configurations must be set up before enabling playback. The FLL can be used to generate a free-running clock in the absence of an external reference source; see “Free-Running FLL Clock” for further details. See “Internal / External Clock Generation” for further details of the PLL and FLL circuits.

The WM8962B supports automatic clocking configuration. The programmable dividers associated with the ADCs, DACs, DSP core functions, Class D switching and DC servo are configured automatically, with values determined from the MCLK_RATE and SAMPLE_RATE fields. The user must also configure the OPCLK (if required), the TOCLK (if required) and the digital audio interface.

ADC/DAC oversample rates of 64fs or 128fs are supported (based on a 48kHz sample rate).

A 256kHz clock, supporting a number of internal functions, is derived from SYSCLK.

The Class D switching amplifier and DC servo control circuits are clocked from SYSCLK.

A GPIO Clock, OPCLK, can be derived from SYSCLK and output on a GPIO pin to provide clocking to other devices. This clock is enabled by OPCLK_ENA and controlled by OPCLK_DIV.

A slow clock, TOCLK, is used to set the timeout period for volume updates when zero-cross detect is used. This clock is enabled by TOCLK_ENA and controlled by TOCLK_DIV. A de-bounce clock, DBCLK, is used to control the de-bouncing of button/accessory detect GPIO inputs and selected interrupt inputs. This clock is enabled automatically whenever GPIO or interrupt de-bouncing is selected. The de-bounce clock frequency is controlled by DBCLK_DIV.

In master mode, BCLK is derived from DSPCLK via a programmable divider set by BCLK_DIV. In master mode, the LRCLK is derived from BCLK via a programmable divider AIF_RATE.

In Slave mode, BCLK and LRCLK are inputs to the WM8962B, allowing another digital audio interface to drive these pins. See the “BCLK and LRCLK Control” sub-section for specific operating constraints in this configuration.

The control registers associated with Clocking and Sample Rates are shown in Table 98 to Table 103.

The overall clocking scheme for the WM8962B is illustrated in Figure 57.

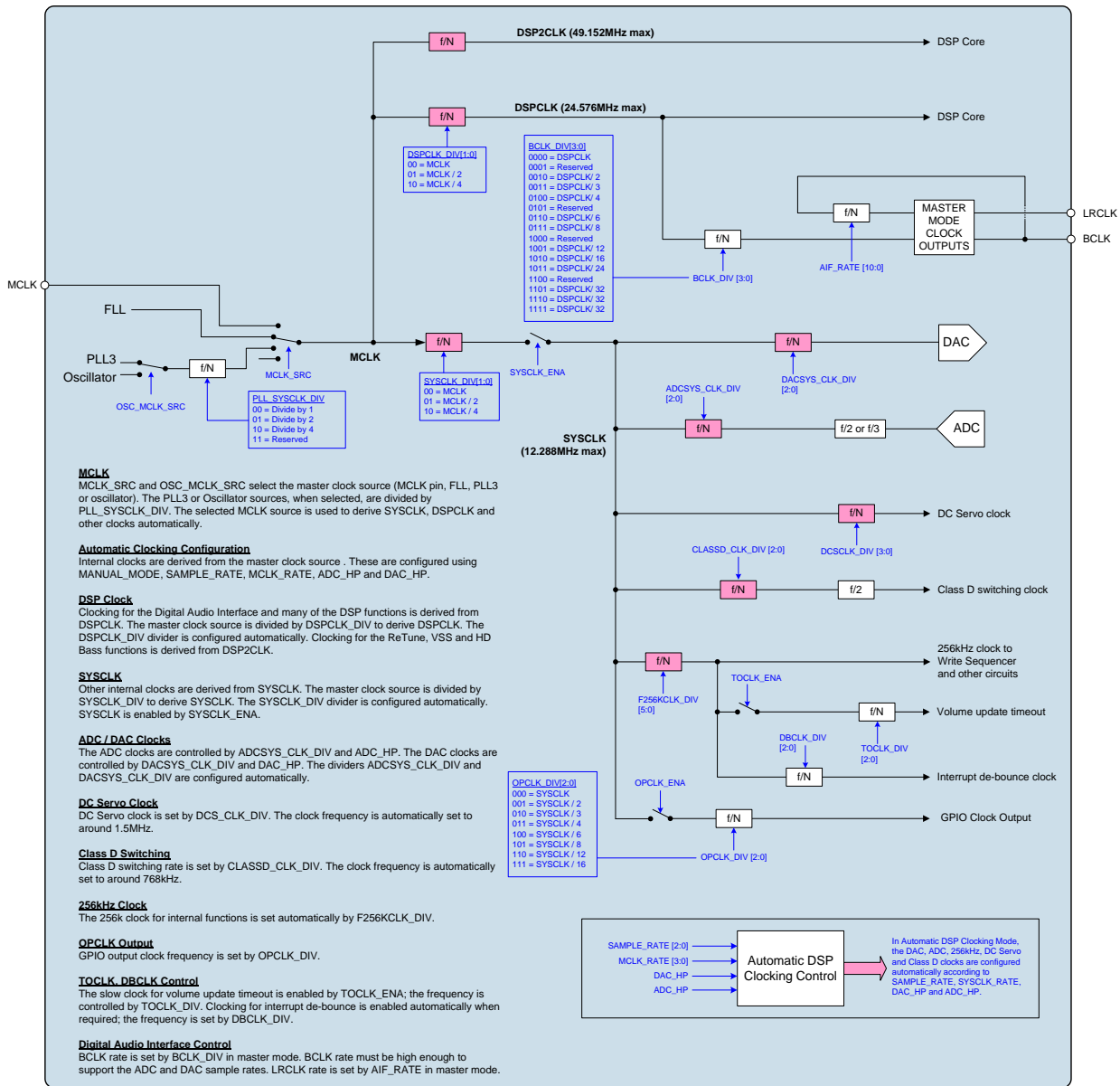

Figure 57 SYSCLK and Internal Clocking Scheme

SYSCLK CONTROL

The MCLK_SRC and OSC_MCLK_SRC registers are used to select the source for MCLK. The source may be either the MCLK pin, FLL, PLL3 or Oscillator. The PLL3 or Oscillator sources, when selected, are controlled by the PLL_SYSCLK_DIV divider.

The selected source may be adjusted by the programmable divider SYSCLK_DIV; this is configured automatically by the WM8962B to ensure that SYSCLK <= 12.288MHz. (Note that the SYSCLK_DIV divider is a read-only register; it cannot be written to.)

The MCLK_SRC register is controlled automatically under certain circumstances, as described below. The associated control register, CLKREG_OVD, is defined in the following section (“Automatic Clocking Configuration”).

When a logic 1 is applied on the GPIO5 pin, the MCLK_SRC register is set to 01b, selecting FLL as the source. In this case, the MCLK_SRC register is locked to prevent accidental writes to this register. The MCLK_SRC register can be unlocked by setting the CLKREG_OVD bit.

When a logic 0 is applied on the GPIO5 pin, the MCLK_SRC register defaults to 00b, selecting MCLK as the source. In this case, the default (00b) is selected on the falling edge of GPIO5; other settings can then be selected by writing to the MCLK_SRC register as normal.

Note that it is important that the GPIO5 input is held in a defined logic state (logic '0' or logic '1') during start-up; it must not be left floating. If normal GPIO functionality is required on the GPIO5 pin, then the CLKREG_OVD bit must be set to '1' in order to select normal read/write control of all the clocking registers, and to permit GPIO functions. The GPIO5 pin must be held in a defined logic state (logic '0' or logic '1') whenever the pin is configured as an input, including whenever CLKREG_OVD = 0 (default).

See “Internal / External Clock Generation” for more details of the FLL and PLL clock generators.

The SYSCLK signal is enabled by register bit SYSCLK_ENA. This bit should be set to 0 when reconfiguring clock sources.

The following operating frequency limits are recommended when configuring SYSCLK. Failure to observe these limits may result in degraded noise performance.

- MCLK ≥ 3MHz
- If DAC_HP = 1 or ADC_HP = 1, then MCLK ≥ 6MHz

The valid clocking ratios for DAC and/or ADC operation are identified in Table 96. See also Table 97 for details of the supported functions for each combination of Sample Rate and MCLK / fs ratio.

SAMPLE RATE (kHz)	MCLK RATE (MCLK / fs ratio)										
	64	128	192	256	384	512	768	1024	1536	3072	6144
8	1	2	3	4	5	6	6	6	6	6	6
11.025	1	2	3	4	5	6	6	6	6	6	
12	1	2	3	4	5	6	6	6	6	6	
16	1	2	3	4	5	6	6	6	6	6	
22.05	1	2	3	4	5	6	6	6	6		
24	1	2	3	4	5	6	6	6	6		
32	1	2	3	4	5	6	6	6	6		
44.1	1	2	3	4	5	6	5	6			
48	1	2	3	4	5	6	5	6			
88.2	1	2	3	4	3	4					
96	1	2	3	4	3	4					

Table 96 MCLK / Sample Rate Availability

CODE	DAC/ADC Configuration	ADC Signal Path Enhancements		DAC Signal Path Enhancements		
		HPF, LPF/HPF, DF1 Filter, 3D Surround, Dynamic Range Control (DRC)	ReTune™	Dynamic Range Control (DRC)	5-band EQ	Virtual Surround Sound (VSS), ReTune HD Bass, DAC HPF
1	Mono DAC					
2	Stereo DAC					
3	Stereo DAC			✓	✓	
4	Stereo CODEC	✓		✓		
	or Stereo DAC			✓	✓	
5	Stereo CODEC	✓		✓	✓	
6	Stereo CODEC	✓	✓	✓	✓	✓

Table 97 DAC/ADC and Audio Enhancements Availability

The supported MCLK frequency range is defined in the “Signal Timing Requirements”.

The MCLK / fs ratio is set using the MCLK_RATE register. See “Automatic Clocking Configuration” for details of this register.

The MCLK and SYSCLK control register fields are defined in Table 98.

REGISTER ADDRESS	BIT	LABEL	DEFAULT	DESCRIPTION
R4 (04h) Clocking1	2:1	SYSClk_DIV	00	SYSClk Divider 00 = MCLK 01 = MCLK / 2 10 = MCLK / 4 11 = Reserved This field is for read-back only; it is set automatically and cannot be adjusted. Note that the division is applied to the selected MCLK source, including FLL / PLL when applicable.
R8 (08h) Clocking2	10:9	MCLK_SRC	00	MCLK source select 00 = MCLK pin 01 = FLL output 10 = PLL3 or Oscillator (selected by OSC_MCLK_SRC) 11 = Reserved If CLKREG_OVD = 0, then MCLK_SRC is controlled by the GPIO5 pin. If CLKREG_OVD = 0 and GPIO5 = 1, then MCLK_SRC = 01 (FLL) and MCLK_SRC cannot be changed by the Control Interface. If CLKREG_OVD = 0 and GPIO5 = 0, then MCLK_SRC = 00 (MCLK) by default, but the value can be changed via the Control Interface. If CLKREG_OVD = 1 then MCLK_SRC = 00 (MCLK) by default, but the value can be changed via the Control Interface.
	5	SYSClk_ENA	1	SYSClk enable 0 = Disabled 1 = Enabled
R125 (7Dh) Analogue Clocking2	4:3	PLL_SYSClk_DIV	01	PLL3 / Oscillator to MCLK divider 00 = Divide by 1 01 = Divide by 2 10 = Divide by 4 11 = Reserved
R152 (98h) Analogue Clocking 4	4	OSC_MCLK_SRC	0	PLL3 / Oscillator to MCLK source 0 = PLL3 1 = Oscillator This field selects the MCLK source, when MCLK_SRC = 10.

Table 98 MCLK and SYSClk Control

AUTOMATIC CLOCKING CONFIGURATION

The WM8962B supports a wide range of standard audio sample rates from 8kHz to 96kHz. The Automatic Clocking Configuration mode simplifies the configuration of the clock dividers in the WM8962B by deriving most of the necessary parameters from a minimum number of user registers.

In Automatic mode, the SAMPLE_RATE field selects the sample rate, fs, of the ADC and DAC. The SAMPLE_RATE_INT_MODE bit should be set according to the selected SAMPLE_RATE, as described in Table 99. Note that, in Automatic mode, the same sample rate always applies to the ADC and DAC.

In Automatic mode, the MCLK_RATE field must be set according to the ratio of MCLK to fs. (Note that the MCLK source is selected by MCLK_SRC - see Table 98.)

Selectable modes of ADC / DAC operation are available using the ADC_HP and DAC_HP register bits. The automatic clocking configuration uses these bits to determine the applicable clock divider settings.

The WM8962B is designed to support specific internal and external clocking configurations. Under default conditions, the GPIO5 pin has control over selected clocking registers, and normal read/write access to some registers is not supported. When the CLKREG_OVD register is set to 1, the affected clocking registers are controlled as normal via the Control Interface. The registers that are affected by CLKREG_OVD are noted in Table 99.

REGISTER ADDRESS	BIT	LABEL	DEFAULT	DESCRIPTION
R6 (06h) ADC & DAC Control 2	0	DAC_HP	0	DAC Oversampling Ratio 0 = Low Power (typically 64 x fs) 1 = High Performance (typically 128 x fs)
R8 (08h) Clocking2	11	CLKREG_OVD	0	Clock Configuration Override 0 = MCLK_SRC, OSC_ENA and CLKOUT5_SEL registers are controlled by the GPIO5 pin; PLL2_ENA, PLL3_ENA, CLKOUT2_DIV, CLKOUT5_DIV and CLKOUT3_SEL registers are locked to fixed values. 1 = Clocking registers are controlled as normal via Control Interface. This bit must be set to 1 to support GPIO functionality on GPIO5.
R23 (17h) Additional Control (1)	5	ADC_HP	0	ADC Oversampling Ratio 0 = Low Power (typically 64 x fs) 1 = High Performance (typically 128 x fs)
R27 (1Bh) Additional Control (3)	4	SAMPLE_RATE_INT_MODE	1	Selects the Integer or Fractional value of the SAMPLE_RATE register. 0 = 11.025k, 22.05k, 44.1k or 88.2kHz 1 = 8k, 12k, 16k, 24k, 32k, 48k or 96kHz
	2:0	SAMPLE_RATE [2:0]	000	Selects the Sample Rate (fs) 000 = 44.1kHz, 48kHz 001 = 32kHz 010 = 22.05kHz, 24kHz 011 = 16kHz 100 = 11.025kHz, 12kHz 101 = 8kHz 110 = 88.2kHz, 96kHz 111 = Reserved

REGISTER ADDRESS	BIT	LABEL	DEFAULT	DESCRIPTION
R56 (38h) Clocking 4	4:1	MCLK_RATE [3:0]	0011	<p>Selects the MCLK / fs ratio. (Note that the MCLK source is selected by MCLK_SRC.)</p> <p>0000 = 64 0001 = 128 0010 = 192 0011 = 256 (default) 0100 = 384 0101 = 512 0110 = 768 0111 = 1024 1000 = Reserved 1001 = 1536 1010 = 3072 1011 = 6144</p> <p>If ADC ReTune, DAC ReTune, DAC HPF, VSS or HD Bass is enabled, then MCLK_RATE must be 512 or higher.</p>

Table 99 Automatic Clocking Configuration Control

DSP, ADC, DAC CLOCK CONTROL

The clocking of the DSP is derived from MCLK. The clocking of the ADC and DAC circuits is derived from SYSCLK. The associated dividers are configured automatically by the WM8962B.

The DSP clocking rate is controlled by DSPCLK_DIV. In automatic clocking mode, this is configured automatically by the WM8962B to ensure $DSPCLK \leq 24.576\text{MHz}$. (Note that the DSPCLK_DIV divider is a read-only register; it cannot be written to.)

The ADC clocking rate is controlled by ADCSYS_CLK_DIV. In automatic clocking mode, the WM8962B uses this divider to derive the most suitable $SYSCLK / fs$ ratio, where fs is the ADC sampling rate.

The DAC clocking rate is controlled by DACSYS_CLK_DIV. In automatic clocking mode, the WM8962B uses this divider to derive the most suitable $SYSCLK / fs$ ratio, where fs is the DAC sampling rate.

REGISTER ADDRESS	BIT	LABEL	DEFAULT	DESCRIPTION
R4 (04h) Clocking 1	10:9	DSPCLK_DIV [1:0]	00	DSP Clock Divider 00 = MCLK 01 = MCLK / 2 10 = MCLK / 4 11 = Reserved This field is for read-back only; it is set automatically and cannot be adjusted.
	8:6	ADCSYS_CLK_DIV [2:0]	000	ADC Sample Rate Divider 000 = SYSCLK 001 = Reserved 010 = SYSCLK / 2 011 = SYSCLK / 3 100 = SYSCLK / 4 101 = Reserved 110 = SYSCLK / 6 111 = Reserved This field is for read-back only; it is set automatically and cannot be adjusted.
	5:3	DACSYS_CLK_DIV [2:0]	100	DAC Sample Rate Divider 000 = SYSCLK 001 = Reserved 010 = SYSCLK / 2 011 = SYSCLK / 3 100 = SYSCLK / 4 101 = Reserved 110 = SYSCLK / 6 111 = Reserved This field is for read-back only; it is set automatically and cannot be adjusted.

Table 100 DSP, ADC, DAC Clock Control

CLASS D, 256K, DC SERVO CLOCK CONTROL

The clocking of the Class D amplifier, DC Servo and other functions is derived from SYSCLK. The associated dividers are configured automatically by the WM8962B.

The Class D amplifier switching frequency is controlled by CLASSD_CLK_DIV. In automatic clocking mode, the WM8962B uses this divider to generate a Class D clock that is approximately 768kHz. (Note that there is an additional divide by two in the output stage producing a 384kHz switching frequency.)

A 256kHz clock is required for other circuits, including the Control Write Sequencer. In automatic clocking mode, the WM8962B uses F256KCLK_DIV to generate a clock that is approximately 256kHz.

The DC Servo clock frequency is controlled by DCSCCLK_DIV. In automatic clocking mode, the WM8962B uses this divider to generate a clock that is approximately 1.5MHz.

REGISTER ADDRESS	BIT	LABEL	DEFAULT	DESCRIPTION
R8 (08h) Clocking2	8:6	CLASSD_CLK_DIV [2:0]	111	Class D Clock Divider 000 = SYSCLK 001 = SYSCLK / 2 010 = SYSCLK / 3 011 = SYSCLK / 4 100 = SYSCLK / 6 101 = SYSCLK / 8 110 = SYSCLK / 12 111 = SYSCLK / 16 This field is for read-back only; it is set automatically and cannot be adjusted.
R30 (1Eh) Clocking 3	6:1	F256KCLK_DIV [5:0]	2Fh	256kHz Clock Divider 0d = SYSCLK 1d = SYSCLK / 2 2d = SYSCLK / 3 63d = SYSCLK / 64 This field is for read-back only; it is set automatically and cannot be adjusted.
R56 (38h) Clocking 4	8:5	DCSCCLK_DIV [3:0]	1000	DC Servo Clock Divider 0000 = SYSCLK 0001 = SYSCLK / 1.5 0010 = SYSCLK / 2 0011 = Reserved 0100 = SYSCLK / 3 0101 = SYSCLK / 4 0110 = Reserved 0111 = SYSCLK / 6 1000 = SYSCLK / 8 1001 to 1111 = Reserved This field is for read-back only; it is set automatically by the WM8962B.

Table 101 Class D, 256k, DC Servo Clock Control

OPCLK CONTROL

A clock output (OPCLK) derived from SYSCLK may be output on a GPIO pin. This clock is enabled by register bit OPCLK_ENA, and its frequency is controlled by OPCLK_DIV.

This output of this clock is also dependent upon the GPIO register settings described in the General Purpose Input/Output (GPIO)" section.

REGISTER ADDRESS	BIT	LABEL	DEFAULT	DESCRIPTION
R25 (19h) Pwr Mgmt (1)	9	OPCLK_ENA	0	GPIO Clock Output Enable 0 = Disabled 1 = Enabled
R30 (1Eh) Clocking 3	12:10	OPCLK_DIV [2:0]	000	GPIO Output Clock Divider 000 = SYSCLK 001 = SYSCLK / 2 010 = SYSCLK / 3 011 = SYSCLK / 4 100 = SYSCLK / 6 101 = SYSCLK / 8 110 = SYSCLK / 12 111 = SYSCLK / 16 000 = SYSCLK / 16

Table 102 OPCLK Control
TOCLK, DBCLK CONTROL

A slow clock (TOCLK) is derived from the internally generated 256kHz clock to enable input de-bouncing and volume update timeout functions. This clock is enabled by register bit TOCLK_ENA, and its frequency is controlled by TOCLK_DIV.

A de-bounce clock, DBCLK, is used to control the de-bouncing of GPIO inputs and selected interrupt inputs. This clock is enabled automatically whenever GPIO or interrupt de-bouncing is selected. The de-bounce clock frequency is controlled by DBCLK_DIV.

REGISTER ADDRESS	BIT	LABEL	DEFAULT	DESCRIPTION
R23 (17h) Additional Control(1)	0	TOCLK_ENA	0	TOCLK Enable 0 = Disabled 1 = Enabled
R30 (1Eh) Clocking 3	15:13	DBCLK_DIV [2:0]	000	DBCLK Rate Divider (divides the 256kHz clock; nominal frequency is quoted in brackets) 000 = f / 256 (1kHz) 001 = f / 2048 (125Hz) 010 = f / 4096 (62.5Hz) 011 = f / 8192 (31.2Hz) 100 = f / 16384 (15.6Hz) 101 = f / 32768 (7.8Hz) 110 = f / 64536 (3.9Hz) 111 = f / 131072 (1.95Hz)
	9:7	TOCLK_DIV [2:0]	000	TOCLK Rate Divider (divides the 256kHz clock; nominal frequency is quoted in brackets) 000 = f / 256 (1kHz) 001 = f / 512 (500Hz) 010 = f / 1024 (250Hz) 011 = f / 2048 (125Hz) 100 = f / 4096 (62.5Hz) 101 = f / 8192 (31.2Hz) 110 = f / 16384 (15.6Hz) 111 = f / 32768 (7.8Hz)

Table 103 TOCLK, DBCLK Control

BCLK AND LRCLK CONTROL

In master mode, BCLK is derived from DSPCLK via a programmable division set by BCLK_DIV.

In master mode, LRCLK is derived from BCLK via a programmable division set by AIF_RATE.

See “Digital Audio Interface Control” for details of these fields.

In Slave mode, BCLK/LRCLK should not be stopped whilst a DAC to Speaker playback path is active unless SYSCLK is also stopped. Failure to meet this requirement may result in a DC output at the speaker outputs, and possible speaker damage.

In Slave mode, if BCLK/LRCLK may stop during DAC to Speaker playback then it is recommended to use a SYSCLK source that will also stop at the same time as BCLK/LRCLK. It is important to note that the FLL will continue to run even when its input reference is removed; if the FLL is selected as the SYSCLK source, then SYSCLK will not stop if BCLK/LRCLK is stopped.

If SYSCLK is stopped whenever BCLK/LRCLK is stopped, or if the audio interface is operating in Master mode, then no specific action is required in relation to BCLK/LRCLK stopping.

If BCLK/LRCLK may stop during DAC to Speaker playback, with SYSCLK still running, then it is recommended to disable the Speaker output (see “Output Signal Path”) or to disable the DAC to Speaker Mixer paths (see “Speaker Output Paths”) before stopping BCLK/LRCLK.

If it is not possible to change the WM8962B settings before BCLK/LRCLK are stopped (ie. the BCLK/LRCLK inputs may stop unpredictably), then the DAC 2nd order HPF should be enabled in order to remove DC offsets in the output signal. See “DAC Signal Path Enhancements” for details of this feature.

CONTROL INTERFACE CLOCKING

Register map access is possible with or without a system clock (SYSCLK). The source for SYSCLK may be either the MCLK pin, FLL or PLL3, as described above in the “SYSCLK Control” section.

When SYSCLK_ENA = 1, then an active clock source for SYSCLK must be present for control interface clocking. If the SYSCLK source is stopped, then SYSCLK_ENA must be set to 0 for control register access.

INTERNAL / EXTERNAL CLOCK GENERATION

The WM8962B provides many features to generate clocks for internal and external use. The internal SYSCLK is either generated from MCLK directly, or can be generated using the FLL or using PLL3.

The WM8962B Clock Generation options are illustrated in Figure 58.

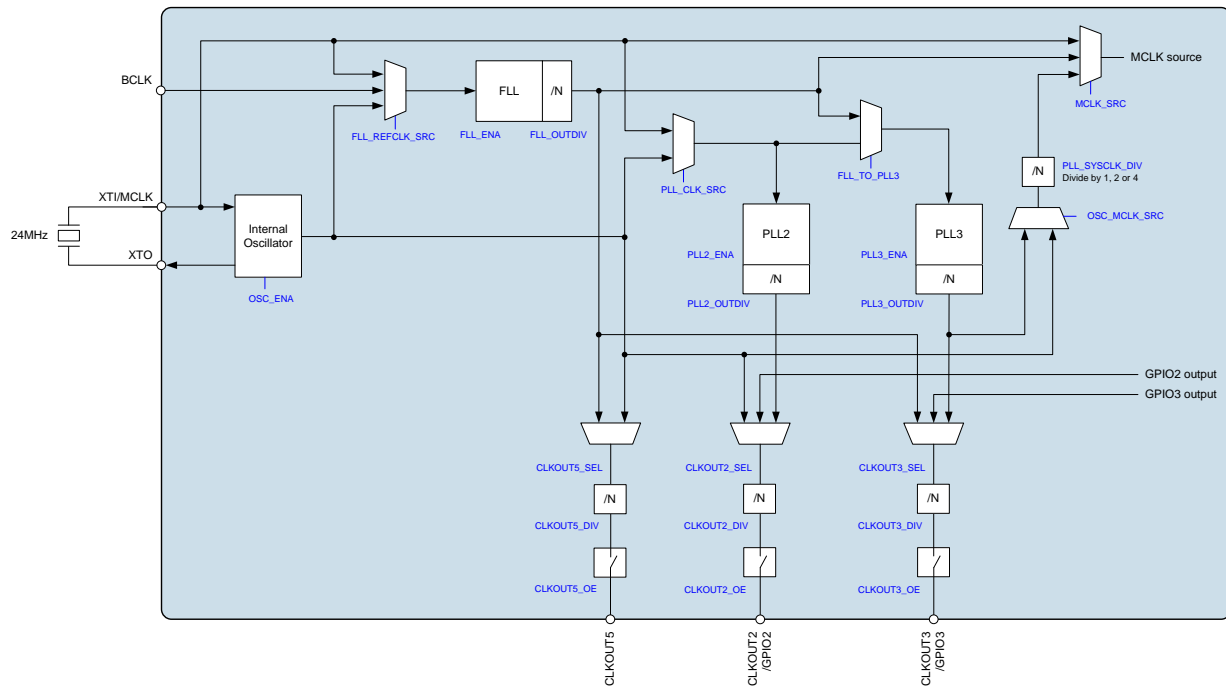

Figure 58 Clock Generation Block Diagram

The MCLK pin supports clock input from external source; this provides a reference for clocking the WM8962B internal circuits via SYSCLK. The WM8962B also provides an internal oscillator circuit, using an external crystal connected to the MCLK pin.

The output of the oscillator can be output directly on the CLKOUT2 or CLKOUT5 pins.

The WM8962B incorporates a Frequency Locked Loop (FLL). The input reference to the FLL is selectable; it can be either the MCLK or BCLK pin directly, or else the internal oscillator. The FLL can be used to generate SYSCLK; it can also be configured to provide an input reference to PLL3.

The WM8962B incorporates two Phase Locked Loop (PLL) circuits. The input reference to these PLLs is selectable; it can either be the MCLK pin directly, or else the internal oscillator. The FLL output can be selected as the input reference for PLL3 if required.

The PLLs can be used to generate a variety of clock signals from the available reference inputs. These are configurable circuits which perform frequency multiplication and frequency division to suit the application requirements. The PLLs are tolerant of jitter on the input reference and can therefore be used to generate a stable output from a less stable input.

The signals generated by PLL2 and PLL3 can be output on the CLKOUT2 and CLKOUT3 pins respectively. If any PLL output is not required, then the respective CLKOUT pin(s) can alternatively be used for GPIO functions.

START-UP OPTIONS FOR INTERNAL / EXTERNAL CLOCK GENERATION

The default (start-up) conditions of the WM8962B can be selected using the GPIO5 pin as a hardware control input. The logic state of the GPIO5 pin during start-up determines the initial value of the clocking control registers, causing different functionality to be selected for each logic state.

Under specific conditions, some of the registers that are controlled by the GPIO5 pin are locked to prevent accidental writes to the affected bit(s). In some cases, the GPIO5 pin determines the initial condition, but the register can still be updated via the Control Interface.

It is possible to unlock all of the clocking control registers, giving full flexibility of the clocking configuration and to enable GPIO functionality on the GPIO5 pin.

The start-up options for the WM8962B are summarised below. The behaviour of the associated clocking control registers is summarised in Table 104.

The WM8962B can be configured to generate a CLKOUT5 output as a default start-up condition. Under default register conditions, with a logic '1' applied to the GPIO5 pin, the CLKOUT5 pin will default to a Clock output that is derived from the Crystal Oscillator. In this configuration, the Oscillator is enabled by default, and the CLKOUT5 frequency is the oscillator frequency divided by 2.

Under default register conditions, with a logic '0' applied to the GPIO5 pin, the crystal oscillator is disabled by default, and no clocks will be present on any of the CLKOUT n pins on start-up.

For full configuration flexibility of the WM8962B Clocking functions, the CLKREG_OVD bit must be set to '1' in order to select normal read/write access to all clocking control registers.

Note that the GPIO5 pin must be held in a defined logic state (logic '0' or logic '1') during start-up; it must not be left floating. Normal GPIO5 functionality can be enabled after start-up, after setting the CLKREG_OVD bit to '1'. The GPIO5 pin must be held in a defined logic state (logic '0' or logic '1') whenever the pin is configured as an input, including whenever CLKREG_OVD = 0.

REGISTER	CLKREG_OVD=0		CLKREG_OVD=1
	GPIO5=0	GPIO5=1	
MCLK_SRC	00 (MCLK)	01 (FLL) *	00 (MCLK)
OSC_ENA	0 (Disabled) *	1 (Enabled)	1 (Enabled)
CLKOUT3_SEL	10 (FLL) *		00 (PLL3)
CLKOUT5_SEL	1 (FLL) *	0 (Oscillator)	0 (Oscillator)
CLKOUT2_DIV	1 (Divide by 2) *		0 (Divide by 1)
CLKOUT5_DIV	1 (Divide by 2) *		0 (Divide by 1)
PLL2_ENA	0 (Disabled) *		1 (Enabled)
PLL3_ENA	0 (Disabled) *		1 (Enabled)
Note - The register settings marked (*) are locked to prevent accidental writes to these registers.			

Table 104 Start-Up Options for Internal / External Clock Generation

The register settings described in Table 104 are the initial/default values corresponding to each GPIO5 condition and each CLKREG_OVD condition. (Note that other clocking configuration registers, which have no dependency on GPIO5 or CLKREG_OVD, are not listed in Table 104.)

When CLKREG_OVD=0, then the register settings marked (*) are locked to prevent accidental writes to the associated registers.

When CLKREG_OVD=1, then all of the clocking control fields can be written via the Control Interface.

The MCLK_SRC register is described in the "Clocking and Sample Rates" section. The other registers referenced above are described later in this section.

INTERNAL OSCILLATOR CONTROL

The internal oscillator is enabled by OSC_ENA. The oscillator is suitable for operation at 24MHz, using a suitable external crystal. The oscillator should be enabled when an external crystal is connected to MCLK to provide clocking; it should be disabled when an external clock is connected to MCLK.

The OSC_ENA register is controlled automatically under certain circumstances, as described below. The associated control register, CLKREG_OVD, is defined in the “Automatic Clocking Configuration” section, (see “Clocking and Sample Rates”).

When a logic 0 is applied on the GPIO5 pin, the OSC_ENA register is set 0. In this case, the OSC_ENA register is locked to prevent accidental writes to this register. The OSC_ENA register can be unlocked by setting the CLKREG_OVD bit.

When a logic 1 is applied on the GPIO5 pin, the OSC_ENA register defaults to 1. In this case, the default (1) is selected on the rising edge of GPIO5; other settings can then be selected by writing to the OSC_ENA register as normal.

Note that, if GPIO functionality is required on the GPIO5 pin, then the CLKREG_OVD bit must be set to ‘1’ in order to select normal read/write control of the OSC_ENA register.

REGISTER ADDRESS	BIT	LABEL	DEFAULT	DESCRIPTION
R129 (81h) PLL 2	7	OSC_ENA	0	Internal Oscillator Enable 0 = Disabled 1 = Enabled If CLKREG_OVD = 0, then OSC_ENA is controlled by the GPIO5 pin. If CLKREG_OVD = 0 and GPIO5 = 0, then OSC_ENA = 0 and cannot be changed by the Control Interface. If CLKREG_OVD = 0 and GPIO5 = 1, then OSC_ENA = 1 by default, but the value can be changed via the Control Interface. If CLKREG_OVD = 1, then OSC_ENA = 1 by default, but the value can be changed via the Control Interface.

Table 105 Internal Oscillator Enable

The crystal oscillator requires an external crystal on the XTI and XTO pins. The WM8962B provides internal loading capacitors for the crystal, removing the need for any external capacitors, as shown in Figure 59.

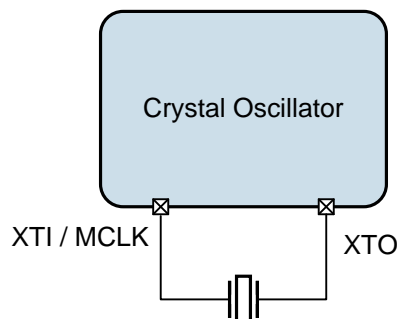

Figure 59 Crystal Oscillator

The internal loading capacitance is detailed in the “Electrical Characteristics”. Selection of the correct crystal component is important to ensure best accuracy and stability of the oscillator.

In cases where the internal loading capacitance differs from the required value (eg. due to characteristics of the chosen crystal, or due to additional capacitive effects of PCB tracks), it is possible to compensate for this within the WM8962B, using the control registers described below.

The compensation in internal loading capacitance (with respect to the default value) must be configured on the XTI and XTO pins individually. The combined effect of the compensation is as per series-connected capacitors; therefore, if the overall difference required is -1pF, then an adjustment of -2pF must be made on each of the XTI and XTO pins. Note that this sum assumes that the difference is the same for both pins.

To apply the capacitive correction, the combined difference (-2pF in the above example) should be applied to XTI_CAP_SEL and XTO_CAP_SEL registers.

It is necessary to ensure that the values written to the XTI_CAP_SEL and XTO_CAP_SEL registers do not cause internal limits to be exceeded; this requires the oscillator trim registers to be read, in order to confirm the amount of calibration already configured to match the specified Electrical Characteristics.

The value written to XTI_CAP_SEL, when summed with the trim value OSC_TRIM_XTI, must not result in a value outside the limits of OSC_TRIM_XTI. The sum of the XTI_CAP_SEL and OSC_TRIM_XTI settings must be between 8pF and 23.5pF.

The value written to XTO_CAP_SEL, when summed with the trim value OSC_TRIM_XTO, must not result in a value outside the limits of OSC_TRIM_XTO. The sum of the XTO_CAP_SEL and OSC_TRIM_XTO settings must be between 8pF and 23.5pF.

As an example, if the read value of OSC_TRIM_XTI is 21.5pF, then it is not possible to increase the XTI capacitance by more than 2pF - a larger value would exceed the 23.5pF limit.

Note that the description provided here assumes that the difference in capacitance (with respect to the recommended value) is the same for both pins (XTI and XTO).

The relevant registers are described in Table 106.

REGISTER ADDRESS	BIT	LABEL	DEFAULT	DESCRIPTION
R115 (73h) Oscillator Trim (3)	4:0	OSC_TRIM_XTI [4:0]		Trimmed Oscillator XTI capacitance 00h = 8pF 01h = 8.5pF ... 0.5pF steps 1Eh = 23pF 1Fh = 23.5pF This field is for read-back only; it is set automatically and cannot be adjusted. see Table 107 for details.
R116 (74h) Oscillator Trim (4)	4:0	OSC_TRIM_XTO [4:0]		Trimmed Oscillator XTO capacitance 00h = 8pF 01h = 8.5pF ... 0.5pF steps 1Eh = 23pF 1Fh = 23.5pF This field is for read-back only; it is set automatically and cannot be adjusted. see Table 107 for details.
R119 (77h) Oscillator Trim (7)	7:4	XTO_CAP_SEL [3:0]	0000	XTO load capacitance adjustment Two's complement format, LSB = 0.5pF Range is -4.0pF to +3.5pF see Table 108 for details
	3:0	XTI_CAP_SEL [3:0]	0000	XTI load capacitance adjustment Two's complement format, LSB = 0.5pF Range is -4.0pF to +3.5pF see Table 108 for details

Table 106 Oscillator Trim Control

OSC_TRIM_XTI, OSC_TRIM_XTO	DESCRIPTION	OSC_TRIM_XTI, OSC_TRIM_XTO	DESCRIPTION
00000	14.0pF	10000	22.0pF
00001	14.5pF	10001	22.5pF
00010	15.0pF	10010	23.0pF
00011	15.5pF	10011	23.5pF
00100	16.0pF	10100	24.0pF
00101	16.5pF	10101	24.5pF
00110	17.0pF	10110	25.0pF
00111	17.5pF	10111	25.5pF
01000	18.0pF	11000	25.5pF
01001	18.5pF	11001	25.5pF
01010	19.0pF	11010	25.5pF
01011	19.5pF	11011	25.5pF
01100	20.0pF	11100	25.5pF
01101	20.5pF	11101	25.5pF
01110	21.0pF	11110	25.5pF
01111	21.5pF	11111	25.5pF

Table 107 Oscillator Trim Register Readback

XTI_CAP_SEL, XTO_CAP_SEL	DESCRIPTION	XTI_CAP_SEL, XTO_CAP_SEL	DESCRIPTION
0000	0.0pF	1000	-4.0pF
0001	+0.5pF	1001	-3.5pF
0010	+1.0pF	1010	-3.0pF
0011	+1.5pF	1011	-2.5pF
0100	+2.0pF	1100	-2.0pF
0101	+2.5pF	1101	-1.5pF
0110	+3.0pF	1110	-1.0pF
0111	+3.5pF	1111	-0.5pF

Table 108 Oscillator Trim Adjustment Settings

CLKOUT CONTROL

The WM8962B provides three CLKOUT pins for FLL / PLL output.

The selected function of each is determined by the CLKOUT n _SEL registers, where n represents the applicable pin. The available options are indicated in the register descriptions shown in Table 109.

The CLKOUT3_SEL register is controlled automatically under certain circumstances, as noted in Table 109. The associated control register, CLKREG_OVD, is defined in the “Automatic Clocking Configuration” section, (see “Clocking and Sample Rates”).

The CLKOUT5_SEL register is controlled automatically under certain circumstances, as described below. The associated control register, CLKREG_OVD, is defined in the “Automatic Clocking Configuration” section, (see “Clocking and Sample Rates”).

When a logic 0 is applied on the GPIO5 pin, the CLKOUT5_SEL register is set 1, selecting the FLL as the source. In this case, the CLKOUT5_SEL register is locked to prevent accidental writes to this register. The CLKOUT5_SEL register can be unlocked by setting the CLKREG_OVD bit.

When a logic 1 is applied on the GPIO5 pin, the CLKOUT5_SEL register defaults to 0, selecting the Oscillator as the source. In this case, the default (0) is selected on the rising edge of GPIO5; other settings can then be selected by writing to the CLKOUT5_SEL register as normal.

Note that, if GPIO functionality is required on the GPIO5 pin, then the CLKREG_OVD bit must be set to ‘1’ in order to select normal read/write control of the CLKOUT5_SEL register.

Each of the CLKOUT pins can be enabled or tri-stated using the CLKOUT_n_OE registers. When a pin is tri-stated, it does not support either the PLL/FLL output or the GPIO function. See “General Purpose Input/Output (GPIO)” for more details of the GPIO functions.

A selectable divider is available on each of the CLKOUT pins. When the CLKOUT_n_DIV bit is set, then the respective Clock output is divided by two. Note that, when the selected function is GPIO, then the CLKOUT_n_DIV bit should be set to 0.

The CLKOUT2_DIV and CLKOUT5_DIV registers are controlled automatically under certain circumstances, as noted in Table 109. The associated control register, CLKREG_OVD, is defined in the “Automatic Clocking Configuration” section, (see “Clocking and Sample Rates”).

REGISTER ADDRESS	BIT	LABEL	DEFAULT	DESCRIPTION
R124 (7Ch) Analogue Clocking1	6:5	CLKOUT2_SEL [1:0]	00	CLKOUT2 Output Select 00 = PLL2 01 = GPIO2 10 = Internal oscillator 11 = Reserved
	4:3	CLKOUT3_SEL [1:0]	10	CLKOUT3 Output Select 00 = PLL3 01 = GPIO3 10 = FLL 11 = Reserved If CLKREG_OVD = 0, then CLKOUT3_SEL = 10 (FLL) and cannot be changed by the Control Interface. If CLKREG_OVD = 1, then CLKOUT3_SEL = 00 (PLL3) by default, but the value can be changed via the Control Interface.
	0	CLKOUT5_SEL	1	CLKOUT5 Output Select 0 = Internal oscillator 1 = FLL If CLKREG_OVD = 0, then CLKOUT5_SEL is controlled by the GPIO5 pin. If CLKREG_OVD = 0 and GPIO5 = 0, then CLKOUT5_SEL = 1 (FLL) and cannot be changed by the Control Interface. If CLKREG_OVD = 0 and GPIO5 = 1, then CLKOUT5_SEL = 0 (Oscillator) by default, but the value can be changed via the Control Interface. If CLKREG_OVD = 1 then CLKOUT5_SEL = 0 (Oscillator) by default, but the value can be changed via the Control Interface.
R125 (7Dh) Analogue Clocking2	2	CLKOUT3_DIV	0	CLKOUT3 Output Divide 0 = Divide by 1 1 = Divide by 2
	1	CLKOUT2_DIV	1	CLKOUT2 Output Divide 0 = Divide by 1 1 = Divide by 2 If CLKREG_OVD = 0, then CLKOUT2_DIV = 1 (Divide by 2) and cannot be changed by the Control Interface. If CLKREG_OVD = 1, then CLKOUT2_DIV = 0 by default, but the value can be changed via the Control Interface.

REGISTER ADDRESS	BIT	LABEL	DEFAULT	DESCRIPTION
	0	CLKOUT5_DIV	1	CLKOUT5 Output Divide 0 = Divide by 1 1 = Divide by 2 If CLKREG_OVD = 0, then CLKOUT5_DIV = 1 (Divide by 2) and cannot be changed by the Control Interface. If CLKREG_OVD = 1, then CLKOUT5_DIV = 0 by default, but the value can be changed via the Control Interface.
R126 (7Eh) Analogue Clocking3	3	CLKOUT2_OE	1	CLKOUT2 Output Enable 0 = Disabled (tri-state) 1 = Enabled
	2	CLKOUT3_OE	1	CLKOUT3 Output Enable 0 = Disabled (tri-state) 1 = Enabled
	0	CLKOUT5_OE	1	CLKOUT5 Output Enable 0 = Disabled (tri-state) 1 = Enabled

Table 109 CLKOUT Control

FREQUENCY LOCKED LOOP (FLL)

The WM8962B incorporates a Frequency Locked Loop (FLL) circuit. The FLL uses a highly accurate and configurable circuit to generate SYSCLK from a wide variety of different reference sources and frequencies.

The FLL input reference may be a high frequency (eg. 36.864MHz) or low frequency (eg. 32,768kHz). The FLL is tolerant of jitter and may be used to generate a stable SYSCLK from a less stable input signal. The FLL characteristics are summarised in “Electrical Characteristics”.

Note that the FLL can be used to generate a free-running clock in the absence of an external reference source. This is described in the “Free-Running FLL Clock” section below. This feature enables clocked functions (such as microphone/accessory detection interrupts) to be supported when the external reference clock or crystal oscillator is not enabled.

The input reference to the FLL is selected by FLL_REFCLK_SRC. The available options are MCLK, BCLK or the internal oscillator.

The FLL control registers are illustrated in Figure 60.

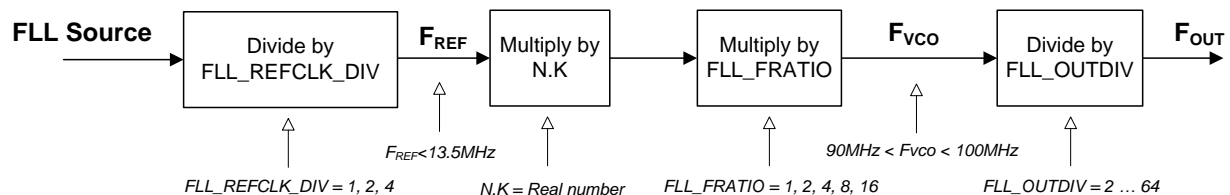
Figure 60 FLL Configuration

The FLL is enabled using the FLL_ENA register bit. Note that, when changing FLL settings, it is recommended that the digital circuit be disabled via FLL_ENA and then re-enabled after the other register settings have been updated. When changing the input reference frequency F_{REF}, it is recommended the FLL be reset by setting FLL_ENA to 0.

The field FLL_REFCLK_DIV provides the option to divide the input reference (MCLK, BCLK or Internal Oscillator) by 1, 2 or 4. This field should be set to bring the reference down to 13.5MHz or below. For best performance, it is recommended that the highest possible frequency - within the 13.5MHz limit - should be selected.

The FLL output frequency is directly determined from FLL_FRATIO, FLL_OUTDIV and the real number represented by N.K.

The integer value, N, is held in the FLL_N register field, and is used in both Integer and Fractional Modes. The fractional portion, K, is only valid in Fractional Mode when enabled by the field FLL_FRAC. The value of K is determined by the ratio FLL_THETA / FLL_LAMBDA.

It is recommended that FLL Fractional mode is enabled at all times (FLL_FRAC = 1). Power consumption in the FLL is reduced in integer mode (FLL_FRAC = 0). However, the performance may also be reduced, with increased noise or jitter on the output.

The FLL output frequency is generated according to the following equation:

$$F_{OUT} = (F_{VCO} / FLL_OUTDIV)$$

The FLL operating frequency, F_{VCO} is set according to the following equation:

$$F_{VCO} = (F_{REF} \times N.K \times FLL_FRATIO)$$

F_{REF} is the input frequency, as determined by FLL_REFCLK_DIV.

F_{VCO} must be in the range 90-100 MHz. Frequencies outside this range cannot be supported.

Note that the output frequencies that do not lie within the ranges quoted above cannot be guaranteed across the full range of device operating temperatures.

In order to follow the above requirements for F_{VCO} , the value of FLL_OUTDIV should be selected according to the desired output F_{OUT} . The FLL_OUTDIV register must be set so that F_{VCO} is in the range 90-100MHz. The available ratios are integers from 2 to 64. Some typical settings of FLL_OUTDIV are noted in Table 110.

OUTPUT FREQUENCY F_{OUT}	FLL_OUTDIV
1.875 MHz - 2.0833 MHz	101111 (F_{OUT} clock ratio = 48)
2.8125 MHz - 3.125 MHz	011111 (F_{OUT} clock ratio = 32)
3.75 MHz - 4.1667 MHz	010111 (F_{OUT} clock ratio = 24)
5.625 MHz - 6.25 MHz	001111 (F_{OUT} clock ratio = 16)
11.25 MHz - 12.5 MHz	000111 (F_{OUT} clock ratio = 8)
18 MHz - 20 MHz	000100 (F_{OUT} clock ratio = 5)
22.5 MHz - 25 MHz	000011 (F_{OUT} clock ratio = 4)
40 MHz - 50 MHz	000001 (F_{OUT} clock ratio = 2)

Table 110 Selection of FLL_OUTDIV

The value of FLL_FRATIO should be selected as described in Table 111.

REFERENCE FREQUENCY F_{REF}	FLL_FRATIO
1MHz - 13.5MHz	0h (F_{VCO} clock ratio = 1)
256kHz - 1MHz	1h (F_{VCO} clock ratio = 2)
128kHz - 256kHz	2h (F_{VCO} clock ratio = 4)
64kHz - 128kHz	3h (F_{VCO} clock ratio = 8)
Less than 64kHz	4h (F_{VCO} clock ratio = 16)

Table 111 Selection of FLL_FRATIO

In order to determine the remaining FLL parameters, the FLL operating frequency, F_{VCO} , must be calculated, as given by the following equation:

$$F_{VCO} = (F_{OUT} \times FLL_OUTDIV)$$

The value of N.K can then be determined as follows:

$$N.K = F_{VCO} / (FLL_FRATIO \times F_{REF})$$

Note that, in the above equations:

FLL_OUTDIV is the F_{OUT} clock ratio (2...64).

F_{REF} is the input frequency, after division by FLL_REFCLK_DIV, where applicable.

FLL_FRATIO is the F_{VCO} clock ratio (1, 2, 4, 8 or 16).

The value of N is held in the FLL_N register field.

The value of K is determined by the ratio FLL_THETA / FLL_LAMBDA.

The FLL_N, FLL_THETA and FLL_LAMBDA fields are all coded as integers (LSB = 1).

Note that FLL_LAMBDA must be set to a non-zero value in Integer and Fractional modes.

In Fractional Mode (FLL_FRAC = 1), the register fields FLL_THETA and FLL_LAMBDA can be calculated as follows:

Calculate GCD(FLL) using the greatest common denominator function:

$$GCD(FLL) = GCD(FLL_FRATIO \times F_{REF}, F_{VCO})$$

where GCD(x, y) is the greatest common denominator of x and y

Next, calculate FLL_THETA and FLL_LAMBDA using the following equations:

$$FLL_THETA = (F_{VCO} - (FLL_N \times FLL_FRATIO \times F_{REF})) / GCD(FLL)$$

$$FLL_LAMBDA = (FLL_FRATIO \times F_{REF}) / GCD(FLL)$$

Note that, in Fractional Mode, the values of FLL_THETA and FLL_LAMBDA must be co-prime (ie. not divisible by any common integer). The calculation above ensures that the values will be co-prime.

The value of K must be a fraction less than 1 (ie. FLL_THETA must be less than FLL_LAMBDA).

For best performance, a non-integer value of N.K must be used. If necessary, it is recommended to adjust FLL_n_OUTDIV in order to obtain a non-integer value of N.K. Care must always be taken to ensure that the FLL operating frequency, F_{VCO}, is within its recommended limits of 90-100 MHz.

The FLL control registers are described in Table 112. An example FLL calculation is shown on the following page.

REGISTER ADDRESS	BIT	LABEL	DEFAULT	DESCRIPTION
R155 (9Bh) FLL Control (1)	3		1	Reserved - Do not change
	2	FLL_FRAC	1	FLL Fractional Mode enable 0 = Integer Mode 1 = Fractional Mode Fractional Mode (FLL_FRAC=1) is recommended in all cases
	0	FLL_ENA	0	FLL Enable 0 = Disabled 1 = Enabled

REGISTER ADDRESS	BIT	LABEL	DEFAULT	DESCRIPTION
R156 (9Ch) FLL Control (2)	8:3	FLL_OUTDIV [5:0]	000111	FLL F _{OUT} clock ratio 000000 = Reserved 000001 = 2 000010 = 3 000011 = 4 000100 = 5 000101 = 6 ... 111110 = 63 111111 = 64 (F _{OUT} = F _{VCO} / FLL_OUTDIV)
	1:0	FLL_REFCLK_D IV [1:0]	01	FLL Clock Reference Divider 00 = MCLK / 1 01 = MCLK / 2 10 = MCLK / 4 11 = Reserved MCLK (or other input reference) must be divided down to ≤13.5MHz. For lower power operation, the reference clock can be divided down further if desired.
R157 (9Dh) FLL Control (3)	8:4		11000	Reserved - Do not change
	2:0	FLL_FRATIO [2:0]	000	FLL F _{VCO} clock ratio 000 = 1 001 = 2 010 = 4 011 = 8 1XX = 16 000 recommended for F _{REF} > 1MHz 011 recommended for F _{REF} < 64kHz
R158 (9Eh) FLL Control (4)	3:0		0000	Reserved - Do not change
R160 (A0h) FLL Control (6)	15:0	FLL_THETA [15:0]	0018h	FLL Fractional multiply for F _{REF} . Only valid when FLL_FRAC = 1. This field sets the numerator (multiply) part of the FLL_THETA / FLL_LAMBDA ratio. It is coded as LSB = 1.
R161 (A1h) FLL Control (7)	15:0	FLL_LAMBDA [15:0]	007Dh	FLL Fractional multiply for F _{REF} . Only valid when FLL_FRAC = 1. This field sets the denominator (dividing) part of the FLL_THETA / FLL_LAMBDA ratio. It is coded as LSB = 1. Note that it is required that FLL_LAMBDA > 0 in all cases (Integer and Fractional modes).
R162 (A2h) FLL Control (8)	9:0	FLL_N [9:0]	008h	FLL Integer multiply for F _{REF} (LSB = 1)

Table 112 FLL Register Controls

FREE-RUNNING FLL CLOCK

The Frequency Locked Loop (FLL) can generate a clock signal even when no external reference is available. However, it should be noted that the accuracy of this clock is reduced, and an external reference source should always be used where possible. Note that, in free-running modes, the FLL is not sufficiently accurate for hi-fi ADC or DAC applications. However, the free-running modes are suitable for clocking most other functions, including the Write Sequencer, Charge Pump, DC Servo and Class D loudspeaker driver. Note that the free-running FLL mode enables microphone/accessory detection interrupts to be supported without external clocking.

If an accurate reference clock is initially available, then the FLL should be configured as described above. The FLL will continue to generate a stable output clock after the reference input is stopped or disconnected.

If no reference clock is available at the time of starting up the FLL, then an internal clock frequency of approximately 12MHz can be generated by implementing the following sequence:

- Enable the FLL Analogue Oscillator (FLL_OSC_ENA = 1)
- Set the F_{OUT} clock divider to divide by 8 (FLL_OUTDIV = 000111)
- Configure the oscillator frequency by setting FLL_FRC_NCO = 1 and FLL_FRC_NCO_VAL = 19h

Note that the free-running FLL mode is not suitable for hi-fi CODEC applications. In the absence of any reference clock, the FLL output is subject to a very wide tolerance; see “Electrical Characteristics” for details of the FLL accuracy.

Note that the free-running FLL clock is selected as SYSCLK using the registers noted in Figure 58.

The free-running FLL clock may be used to support analogue functions, for which the digital audio interface is not used, and there is no applicable Sample Rate (fs). When SYSCLK is required for circuits such as the Class D, DC Servo, Control Write Sequencer or Charge Pump, then valid Sample Rate register settings (SAMPLE_RATE and MCLK_RATE) are still required, even though the digital audio interface is not active.

REGISTER ADDRESS	BIT	LABEL	DEFAULT	DESCRIPTION
R155 (009Bh) FLL Control (1)	1	FLL_OSC_ENA	0	FLL Oscillator enable 0 = Disabled 1 = Enabled (Note that this field is required for free-running FLL modes only)
R159 (009Fh) FLL Control (5)	6:1	FLL_FRC_NCO_VAL	19h	FLL Forced oscillator value Valid range is 000000 to 111111 0x19h (011001) = 12MHz approx (Note that this field is required for free-running FLL modes only)
	0	FLL_FRC_NCO	0	FLL Forced control select 0 = Normal 1 = FLL oscillator controlled by FLL_FRC_NCO_VAL (Note that this field is required for free-running FLL modes only)

Table 113 FLL Free-Running Mode

EXAMPLE FLL CALCULATION

The following example illustrates how to derive the FLL registers to generate 12.288 MHz output (F_{OUT}) from a 13.000 MHz reference clock (F_{REF}):

- Set FLL_REFCLK_DIV in order to generate $F_{REF} \leq 13.5\text{MHz}$:
FLL_REFCLK_DIV = 00 (divide by 1)
- Set FLL_OUTDIV for the required output frequency as shown in Table 110:-
 $F_{OUT} = 12.288\text{ MHz}$, therefore FLL_OUTDIV = 07h (F_{OUT} clock ratio = 8)
- Set FLL_FRATIO for the given reference frequency as shown in Table 111:
 $F_{REF} = 13\text{MHz}$, therefore FLL_FRATIO = 0h (F_{VCO} clock ratio = 1)
- Calculate F_{VCO} as given by $F_{VCO} = F_{OUT} \times FLL_OUTDIV$:-
 $F_{VCO} = 12.288 \times 8 = 98.304\text{MHz}$
- Calculate N.K as given by $N.K = F_{VCO} / (FLL_FRATIO \times F_{REF})$:
 $N.K = 98.304 / (1 \times 13) = 7.561846$
- Determine FLL_N from the integer portion of N.K:-
FLL_N = 7.
- Determine GCD(FLL), as given by $GCD(FLL) = GCD(FLL_FRATIO \times F_{REF}, F_{VCO})$:
 $GCD(FLL) = GCD(1 \times 13000000, 98304000) = 8000$
- Determine FLL_THETA, as given by
 $FLL_THETA = (F_{VCO} - (FLL_N \times FLL_FRATIO \times F_{REF})) / GCD(FLL)$:
 $FLL_THETA = (98304000 - (7 \times 1 \times 13000000)) / 8000$
FLL_THETA = 913 (0391h)
- Determine FLL_LAMBDA, as given by
 $FLL_LAMBDA = (FLL_FRATIO \times F_{REF}) / GCD(FLL)$:
 $FLL_LAMBDA = (1 \times 13000000) / 8000$
FLL_LAMBDA = 1625 (0659h)

PHASE LOCKED LOOP (PLL)

The WM8962B incorporates two PLLs. These are enabled using the respective PLL_n_ENA register bits.

The PLL2_ENA and PLL3_ENA registers are controlled automatically under certain circumstances, as noted in Table 117.

The input reference to the PLLs is selected by PLL_CLK_SRC. The available options are MCLK or the internal oscillator. Under default conditions, the internal oscillator is selected as the reference for all of the PLLs.

In the case of PLL3, the FLL may be selected as the input reference, using FLL_TO_PLL3. When this bit is set, the FLL output is selected as the input reference to PLL3.

The input reference source(s) for the PLLs is selected as defined in Table 114.

REGISTER ADDRESS	BIT	LABEL	DEFAULT	DESCRIPTION
R131 (83h) PLL 4	1	PLL_CLK_SRC	0	PLL Clock Source 0 = Internal oscillator 1 = MCLK Note that the SEQ_ENA bit (Register R150, 96h) must be set to 0 when MCLK is selected as the PLL Clock Source.
	0	FLL_TO_PLL3	0	PLL3 Clock Source 0 = Selected by PLL_CLK_SRC 1 = FLL

Table 114 PLL Reference Select

An internal sequencer ensures correct synchronisation of the PLL circuits; this is enabled by default. Note that, if MCLK is selected as the PLL Clock Source, then the internal sequencer must be disabled.

The PLL Control Sequencer is controlled using the SEQ_ENA register as described in Table 115.

REGISTER ADDRESS	BIT	LABEL	DEFAULT	DESCRIPTION
R150 (96h) PLL DLL	1	SEQ_ENA	1	PLL Control Sequencer Enable 0 = Disabled 1 = Enabled This bit must be set to 0 when MCLK is selected as the PLL Clock Source.

Table 115 PLL Control Sequencer

The PLLs can be configured to derive a wide range of output frequencies from the internal 24MHz crystal oscillator (or external reference). The PLLs can be configured using the control fields in Register R136 through to R143, described below. The PLL configurations are illustrated in Figure 61.

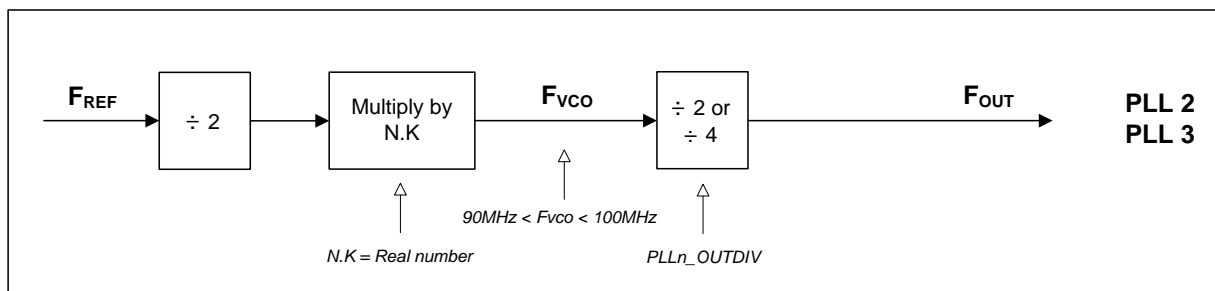

Figure 61 PLL Frequency Control

The output frequency of each PLL is directly determined from PLL_n_OUTDIV and the real numbers represented by the N.K value applicable to each PLL. (Note that *n* is 2 or 3 depending on the applicable PLL.)

For each PLL, the integer value, N, is held in the PLL_n_N register fields, and is used in both Integer and Fractional Modes. The fractional portion, K, is only valid in Fractional Mode when enabled by the field PLL_n_FRAC. The value of K is held in the PLL_n_K register fields.

It is recommended that PLL Fractional mode is enabled at all times (PLL_n_FRAC = 1). Power consumption in the PLL is reduced in integer mode (PLL_n_FRAC = 0). However, the performance may also be reduced, with increased noise or jitter on the output.

The FLL output frequency is generated according to the following equation:

$$F_{OUT} = F_{VCO} / (2 \times PLLn_OUTDIV)$$

The PLL operating frequency, F_{VCO}, is set according to the following equation:

$$F_{VCO} = (F_{REF} \times N.K / 2)$$

F_{REF} is the input frequency (typically 24MHz on the WM8962B).

F_{VCO} must be in the range 90-100 MHz. Note that frequencies that do not lie within this range cannot be guaranteed across the full range of device operating temperatures.

The value of the PLL_n_OUTDIV registers must be set depending on the required output frequency, ensuring that the respective F_{VCO} frequency is within the recommended operating limits. The supported configurations are noted in Table 116.

Note that the CLKOUT_n output frequencies can also be controlled by the CLKOUT_n_DIV registers, as defined in Table 109; these dividers extend the range of clock frequencies that can be output on the CLKOUT pins.

Note that, when PLL3 is selected as the SYSCLK source, the frequency can also be controlled by the PLL_SYSCLK_DIV register, as described in Table 98; this divider provides flexibility in generating the necessary internal and external clock frequencies.

OUTPUT FREQUENCY F _{OUT}	PLL _n _OUTDIV (PLL2, 3, 4)
45 MHz - 50 MHz	PLL _n _OUTDIV = 1 (divide by 2)
22.5 MHz - 25 MHz	PLL _n _OUTDIV = 2 (divide by 4)

Table 116 Selection of PLL_n_OUTDIV

In order to determine the remaining PLL parameters, the PLL operating frequency, F_{VCO}, must be calculated, as given by the following equation:

$$F_{VCO} = (F_{OUT} \times 2 \times PLLn_OUTDIV)$$

The PLL frequency ratio N.K can then be determined as follows:

$$N.K = F_{VCO} \times 2 / F_{REF}$$

The PLL frequency ratio N.K is the real number represented by the register fields PLL_n_N and PLL_n_K (where *n* is 2 or 3, depending on the applicable PLL). The field PLL_n_N is an integer (LSB = 1); PLL_n_K is the fractional portion of the number (MSB = 0.5). The fractional portion is only valid in Fractional Mode, when enabled by the field PLL_n_FRAC.

If N.K is an integer (PLL_n_K = 0), then PLL integer mode should be selected, ie. PLL_n_FRAC = 0. Power consumption in the PLL is reduced in integer mode.

If N.K is not an integer (PLL_n_K > 0), the PLL fractional mode must be selected, ie. PLL_n_FRAC = 1.

For PLL stability, input frequencies and divisions must be chosen so that $5 \leq N \leq 13$. Best performance is achieved for $7 \leq N \leq 9$. Also, the PLL performs best when F_{VCO} is set between 90MHz and 100MHz.

In PLL Fractional Mode, the fractional portion of the N.K multiplier is held in the PLL_n_K register field. This field is coded as a fixed point quantity, where the MSB has a weighting of 0.5. Note that, if desired, the value of this field may be calculated by multiplying K by 2^{24} and treating PLL_n_K as an integer value, as illustrated in the following example:

If $N.K = 7.1111111$, then $K = 0.1111111$

Multiplying K by 2^{24} gives $0.1111111 \times 16777216 = 1864134.92$ (decimal)

Apply rounding to the nearest integer = 1864135 (decimal) = 1C71C7 (hex)

PLL_n_N = 07h

PLL_n_K = 1C71C7h

The PLL Control registers described in Table 117 allow the default output frequencies to be enabled.

REGISTER ADDRESS	BIT	LABEL	DEFAULT	DESCRIPTION
R129 (81h) PLL 2	5	PLL2_ENA	0	PLL2 Enable 0 = Disabled 1 = Enabled If CLKREG_OVD = 0, then PLL2_ENA = 0 (Disabled) and cannot be changed by the Control Interface. If CLKREG_OVD = 1, then PLL2_ENA = 1 by default, but the value can be changed via the Control Interface.
	4	PLL3_ENA	0	PLL3 Enable 0 = Disabled 1 = Enabled If CLKREG_OVD = 0, then PLL3_ENA = 0 (Disabled) and cannot be changed by the Control Interface. If CLKREG_OVD = 1, then PLL3_ENA = 1 by default, but the value can be changed via the Control Interface.
	0		1	Reserved - Do not change

Table 117 PLL Control

The PLL Control registers are described in Table 118. Example PLL calculations are shown on the following page, suitable for generating 12MHz or 24.576MHz clocks from the 24MHz reference.

REGISTER ADDRESS	BIT	LABEL	DEFAULT	DESCRIPTION
R125 (7Dh) Analogue Clocking 2	7	PLL2_OUTDIV	0	PLL2 Output Divider 0 = Divide by 2 1 = Divide by 4
	6	PLL3_OUTDIV	1	PLL3 Output Divider 0 = Divide by 2 1 = Divide by 4
R136 (88h) PLL 9	6	PLL2_FRAC	1	PLL2 Fractional enable 0 = Integer Mode 1 = Fractional Mode (recommended)
	4:0	PLL2_N [4:0]	0_0111	Integer Multiply for PLL2 (LSB = 1)
R137 (89h) PLL 10	7:0	PLL2_K [23:16]	1Ch	Fractional Multiply for PLL2 (MSB = 0.5)
R138 (8Ah) PLL 11	7:0	PLL2_K [15:8]	71h	
R139 (8Bh) PLL 12	7:0	PLL2_K [7:0]	C7h	
R140 (8Ch) PLL 13	6	PLL3_FRAC	1	PLL3 Fractional enable 0 = Integer Mode 1 = Fractional Mode (recommended)
	4:0	PLL3_N [4:0]	0_0111	Integer Multiply for PLL3 (LSB = 1)
R141 (8Dh) PLL 14	7:0	PLL3_K [23:16]	48h	Fractional Multiply for PLL3 (MSB = 0.5)
R142 (8Eh) PLL 15	7:0	PLL3_K [15:8]	22h	
R143 (8Fh) PLL 16	7:0	PLL3_K [7:0]	97h	

Table 118 PLL Frequency Ratio Control

EXAMPLE PLL CALCULATION

A typical application may require a 12MHz clock output and a 24.576MHz clock output from the WM8962B.

In this case, it is recommended that PLL2 should be configured for 24MHz output. Under default conditions, the CLKOUT2_DIV function will apply further division, enabling 12MHz output on the CLKOUT2 pin.

The CLKOUT3 pin is suitable for 24.576MHz output, using the default values of the CLKOUT3_DIV and PLL3_OUTDIV registers.

The following example illustrates how to derive the PLL registers to generate 24.000MHz output (F_{OUT}) from a 24.000 MHz reference clock (F_{REF}).

- Set PLLn_OUTDIV to ensure F_{VCO} is in the range 90MHz to 100MHz.
 $F_{OUT} = 24.000\text{MHz}$, therefore PLLn_OUTDIV = 1 (divide by 4)
- Calculate F_{VCO} as given by $F_{VCO} = F_{OUT} \times \text{PLLn_OUTDIV}$:-
 $F_{VCO} = 24.000 \times 4 = 96.000\text{MHz}$
- Calculate N.K as given by $N.K = (F_{VCO} \times 2) / F_{REF}$:-
 $N.K = (96.000 \times 2) / 24 = 8.0$
- Determine PLLn_N and PLLn_K from the integer and fractional portions of N.K:-
PLLn_N = 8. PLLn_K = 0.0
- N.K is an integer; set PLLn_FRAC = 0.

The following example illustrates how to derive the PLL registers to generate 24.576MHz output (F_{OUT}) from a 24.000 MHz reference clock (F_{REF}).

- Set PLLn_OUTDIV to ensure F_{VCO} is in the range 90MHz to 100MHz.
 $F_{OUT} = 24.576\text{MHz}$, therefore PLLn_OUTDIV = 1 (divide by 4)
- Calculate F_{VCO} as given by $F_{VCO} = F_{OUT} \times \text{PLLn_OUTDIV}$:-
 $F_{VCO} = 24.576 \times 4 = 98.304\text{MHz}$
- Calculate N.K as given by $N.K = (F_{VCO} \times 2) / F_{REF}$:-
 $N.K = (98.304 \times 2) / 24 = 8.192$
- Determine PLLn_N and PLLn_K from the integer and fractional portions of N.K:-
PLLn_N = 8. PLLn_K = 0.192
- Confirm that N.K is a fractional quantity and set PLLn_FRAC:
N.K is fractional. Set PLLn_FRAC = 1.
- Convert PLL_K into integer format:
 $0.192 \times 16777216 = 3221225.472$ (decimal).
- Round off to 3221225 (decimal) = 3126E9h
PLLn_K [23:16] = 31h
PLLn_K [15:8] = 26h
PLLn_K [7:0] = E9h

GENERAL PURPOSE INPUT/OUTPUT (GPIO)

The WM8962B provides four multi-function pins which can be configured to provide a number of different functions. There are two digital output pins on the DBVDD power domain. PLLVDD must also be present for correct functionality. The GPIO pins are:

- CLKOUT2/GPIO2
- CLKOUT3/GPIO3

There are two digital input/output pins on the DBVDD power domain. DCVDD must also be present for correct functionality. The GPIO pins are:

- GPIO5
- CS / GPIO6

Note that, under default conditions, the GPIO5 pin is used as an input to the clocking control functions. The affected registers are described in the “Clocking and Sample Rates” and “Internal / External Clock Generation” sections. It is important that this input is held in a defined logic state (logic ‘0’ or logic ‘1’) during start-up; it must not be left floating. Normal GPIO5 functionality can be enabled after start-up, as described below.

If GPIO functionality is required on the GPIO5 pin, then the CLKREG_OVD bit must be set to ‘1’ in order to select normal read/write control of all the clocking registers, and to permit GPIO functions.

If the CLKREG_OVD bit is set to ‘0’ (default), then the GPIO5 control register (R516) must not be changed from the default value. The GPIO5 pin must be held in a defined logic state (logic ‘0’ or logic ‘1’) whenever the pin is configured as an input, including whenever CLKREG_OVD = 0.

Under default conditions, the GPIO2 pin is configured as the CLKOUT2 function, supporting the PLL2 output. For GPIO2 functionality, set CLKREG_OVD=1, CLKOUT2_SEL=01, CLKOUT2_DIV=0 and CLKOUT2_OE=1. The CLKREG_OVD register must be set to 1 before writing to the other registers.

Under default conditions, the GPIO3 pin is configured as the CLKOUT3 function, supporting the FLL output. For GPIO3 functionality, set CLKREG_OVD=1, CLKOUT3_SEL=01, CLKOUT3_DIV=0 and CLKOUT3_OE=1. The CLKREG_OVD register must be set to 1 before writing to the other registers.

See “Internal / External Clock Generation” for details of the CLKOUT n _SEL, CLKOUT n _DIV and CLKOUT n _OE registers. The CLKREG_OVD register is defined in Table 99 (see “Clocking and Sample Rates”).

For pins GPIO5 and GPIO6, the pin direction, set by GP n _DIR, must be set according to the function selected by GP5_FN or GP6_FN.

The characteristics of pins GPIO5 or GPIO6, if selected as an output, may be controlled by setting GP n _OP_CFG - an output pin may be either CMOS or Open-Drain. When a pin is configured as a GPIO output, its level can be set to logic 0 or logic 1 using the GP n _LVL field.

GPIO5 and GPIO6 pins can be configured as GPIO inputs can be used to trigger an Interrupt event. This input may be configured as active high or active low using the IRQ_POL field. De-bouncing of this input may be enabled using the GP n _DB field. Internal pull-up and pull-down resistors may be enabled using the GP n _PU and GP n _PD fields. (Note that if GP n _PU and GP n _PD are both set for any GPIO pin, then the pull-up and pull-down will be disabled.)

The register fields that control the GPIO pins are described in Table 119.

For each GPIO pin, the selected function is determined by the GP n _FN field, where ‘n’ identifies the GPIO pin (2, 3, 5 or 6). The polarity of the GPIO outputs can be selected using the GP n _POL register bits.

When a pin is configured as a Logic Level output (GP n _DIR = 0, GP n _FN = 01h), its level can be set to logic 0 or logic 1 using the GP n _LVL field.

When the GPIO5 or GPIO6 pin is configured as a Logic Level input (GP n _DIR = 1, GP n _FN = 01h), its level can be read using the GP n _LVL field.

Note that for PLL / FLL / oscillator output on GPIO2 and GPIO3, the CLKOUT_n_SEL registers must be set to the appropriate values (see Table 109). Setting GP_n_FN = 00h is recommended in this case, but it should be noted that the PLL / FLL / oscillator output is only possible using the CLKOUT_n_SEL registers.

REGISTER ADDRESS	BIT	LABEL	DEFAULT	DESCRIPTION
R513 (0201h) GPIO 2	10	GP2_POL	0	GPIO 2 Polarity 0 = Not inverted 1 = Inverted
	6	GP2_LVL	0	GPIO 2 Output Level (when GP2_FN = 00001) 0 = Logic 0 1 = Logic 1 Note that this is a Write-Only register; the Readback value is undefined.
	4:0	GP2_FN[4:0]	0_0000	GPIO 2 Pin Function select 0_0000 = CLKOUT (PLL2 / Oscillator) - see note below 0_0001 = Logic 0 or Logic 1 (depending on GP2_LVL) 0_0010 = SDOUT 0_0011 = IRQ 0_0100 = Temperature shutdown 0_0101 = Reserved 0_0110 = PLL2 Lock 0_0111 = PLL3 Lock 0_1000 = Reserved 0_1001 = FLL Lock 0_1010 = DRC Activity detect 0_1011 = Write Sequencer done 0_1100 = ALC Noise Gate active 0_1101 = ALC Peak Limiter overload 0_1110 = ALC Saturation 0_1111 = ALC level threshold 1_0000 = ALC Level lock 1_0001 = FIFO error indicator 1_0010 = OPCLK 1_0011 = Digital Microphone Clock Output 1_0100 = Reserved 1_0101 = Mic Detect flag 1_0110 = Mic Short Circuit flag 1_0111 to 1_1111 = Reserved Note that PLL2 or the internal oscillator CLKOUT is enabled using CLKOUT2_SEL. Setting GP2_FN = 00h is recommended in this case.
R514 (0202h) GPIO 3	10	GP3_POL	0	GPIO 3 Polarity 0 = Not inverted 1 = Inverted
	6	GP3_LVL	0	GPIO 3 Output Level (when GP3_FN = 00001) 0 = Logic 0 1 = Logic 1 Note that this is a Write-Only register; the Readback value is undefined.

REGISTER ADDRESS	BIT	LABEL	DEFAULT	DESCRIPTION
	4:0	GP3_FN[4:0]	0_0000	GPIO 3 Pin Function select 0_0000 = CLKOUT (PLL3 / FLL) - see note below 0_0001 = Logic 0 or Logic 1 (depending on GP3_LVL) 0_0010 = SDOUT 0_0011 = IRQ 0_0100 = Temperature shutdown 0_0101 = Reserved 0_0110 = PLL2 Lock 0_0111 = PLL3 Lock 0_1000 = Reserved 0_1001 = FLL Lock 0_1010 = DRC Activity detect 0_1011 = Write Sequencer done 0_1100 = ALC Noise Gate active 0_1101 = ALC Peak Limiter overload 0_1110 = ALC Saturation 0_1111 = ALC level threshold 1_0000 = ALC Level lock 1_0001 = FIFO error indicator 1_0010 = OPCLK 1_0011 = Digital Microphone Clock Output 1_0100 = Reserved 1_0101 = Mic Detect flag 1_0110 = Mic Short Circuit flag 1_0111 to 1_1111 = Reserved Note that PLL3 or FLL CLKOUT is enabled using CLKOUT3_SEL. Setting GP3_FN = 00h is recommended in this case.
R516 (0204h) GPIO 5	15	GP5_DIR	1	GPIO5 Direction 0 = Output 1 = Input
	14	GP5_PU	0	GPIO5 pull-up resistor enable 0 = pull-up disabled 1 = pull-up enabled
	13	GP5_PD	0	GPIO5 pull-down resistor enable 0 = pull-up disabled 1 = pull-down enabled
	10	GP5_POL	0	GPIO5 Polarity 0 = Not inverted 1 = Inverted
	9	GP5_OP_CFG		GPIO5 Output pin configuration 0 = CMOS 1 = Open-drain
	8	GP5_DB		GPIO5 input de-bounce 0 = Disabled 1 = Enabled

REGISTER ADDRESS	BIT	LABEL	DEFAULT	DESCRIPTION
	6	GP5_LVL	0	<p>GPIO 5 Level (when GP5_FN = 00001) 0 = Logic 0 1 = Logic 1</p> <p>Write to this bit to set the GPIO5 output. Read from this bit to read GPIO input level.</p> <p>Note that, when GPIO5 is configured as an output (GP5_DIR=0), this is a Write-Only register; the Readback value is undefined.</p>
	4:0	GP5_FN[4:0]	0_0000	<p>GPIO5 Pin Function select</p> <p>0_0000 = Unused 0_0001 = Logic 0 or Logic 1 (depending on GP5_LVL) 0_0010 = SDOUT 0_0011 = IRQ 0_0100 = Temperature shutdown 0_0101 = Reserved 0_0110 = PLL2 Lock 0_0111 = PLL3 Lock 0_1000 = Reserved 0_1001 = FLL Lock 0_1010 = DRC Activity detect 0_1011 = Write Sequencer done 0_1100 = ALC Noise Gate active 0_1101 = ALC Peak Limiter overload 0_1110 = ALC Saturation 0_1111 = ALC level threshold 1_0000 = ALC Level lock 1_0001 = FIFO error indicator 1_0010 = OPCLK 1_0011 = Digital Microphone Clock Output 1_0100 = Digital Microphone Data Input 1_0100 = Reserved 1_0101 = Mic Detect flag 1_0110 = Mic Short Circuit flag 1_0111 to 1_1111 = Reserved</p> <p>Note that GPIO5 functions are only supported when CLKREG_OVD=1. When CLKREG_OVD=0, the contents of Register R516 must not be changed from the default value.</p>
R517 (0205h) GPIO 6	15	GP6_DIR	1	<p>GPIO6 Direction 0 = Output 1 = Input</p>
	14	GP6_PU	0	<p>GPIO6 pull-up resistor enable 0 = pull-up disabled 1 = pull-up enabled</p>
	13	GP6_PD	0	<p>GPIO6 pull-down resistor enable 0 = pull-up disabled 1 = pull-down enabled</p>
	10	GP6_POL	0	<p>GPIO6 Polarity 0 = Not inverted 1 = Inverted</p>

REGISTER ADDRESS	BIT	LABEL	DEFAULT	DESCRIPTION
	9	GP6_OP_CFG		GPIO6 Output pin configuration 0 = CMOS 1 = Open-drain
	8	GP6_DB		GPIO6 input de-bounce 0 = Disabled 1 = Enabled
	6	GP6_LVL	0	GPIO 6 Level (when GP6_FN = 00001) 0 = Logic 0 1 = Logic 1 Write to this bit to set the GPIO6 output. Read from this bit to read GPIO input level. Note that, when GPIO6 is configured as an output (GP6_DIR=0), this is a Write-Only register; the Readback value is undefined.
	4:0	GP6_FN[4:0]	0_0000	GPIO6 Pin Function select 0_0000 = CSB Input 0_0001 = Logic 0 or Logic 1 (depending on GP6_LVL) 0_0010 = Reserved 0_0011 = IRQ 0_0100 = Temperature shutdown 0_0101 = Reserved 0_0110 = PLL2 Lock 0_0111 = PLL3 Lock 0_1000 = Reserved 0_1001 = FLL Lock 0_1010 = DRC Activity detect 0_1011 = Write Sequencer done 0_1100 = ALC Noise Gate active 0_1101 = ALC Peak Limiter overload 0_1110 = ALC Saturation 0_1111 = ALC level threshold 1_0000 = ALC Level lock 1_0001 = FIFO error indicator 1_0010 = OPCLK 1_0011 = Digital Microphone Clock Output 1_0100 = Digital Microphone Data Input 1_0100 = Reserved 1_0101 = Mic Detect flag 1_0110 = Mic Short Circuit flag 1_0111 to 1_1111 = Reserved

Table 119 GPIO Control

INTERRUPTS

The Interrupt Controller has multiple inputs, including the GPIO input, ALC status, PLL lock and FLL lock. Any combination of these inputs can be used to trigger an Interrupt (IRQ) event.

There is an Interrupt Status field associated with each of the IRQ inputs. These are contained in the Interrupt Status Registers (R560 and R561), as described in Table 120. The status of the IRQ inputs can be read from this register at any time, or else in response to the Interrupt Output being signalled via a GPIO pin.

Each of the IRQ inputs can be individually masked or enabled as an input to the Interrupt function, using the bits contained in the Interrupt Status Mask registers (R568 and R569). Note that the

Interrupt Status fields remain valid, even when masked, but the masked bits will not cause the Interrupt Output to be asserted.

The Interrupt Output represents the logical 'OR' of all the unmasked IRQ inputs, as illustrated in Figure 62. The bits within the Interrupt Status register (R560 and R561) are latching fields and, once they are set, they are not reset until a '1' is written to the respective register bit in the Interrupt Status registers. The Interrupt (IRQ) output is not reset until each of the unmasked IRQ inputs has been reset. Note that, if the condition that caused the IRQ input to be asserted is still valid, then the Interrupt Output will remain set even after the Status register has been written to.

The PLL_n_LOCK_EINT, FLL_LOCK_EINT and TEMP_SHUT_EINT inputs to the Interrupt Controller can be de-bounced to avoid false detections. The timeout clock (TOCLK) is required for this function. The de-bounce is enabled on these inputs using the bits in Register R584. The de-bounce clock is enabled automatically whenever interrupt de-bouncing is selected. The de-bounce clock frequency is controlled by DBCLK_DIV as described in "Clocking and Sample Rates".

By default, the Interrupt Output is Active High. The polarity can be inverted using IRQ_POL.

The WM8962B Interrupt Controller circuit is illustrated in Figure 54. The associated control fields are described in Table 120.

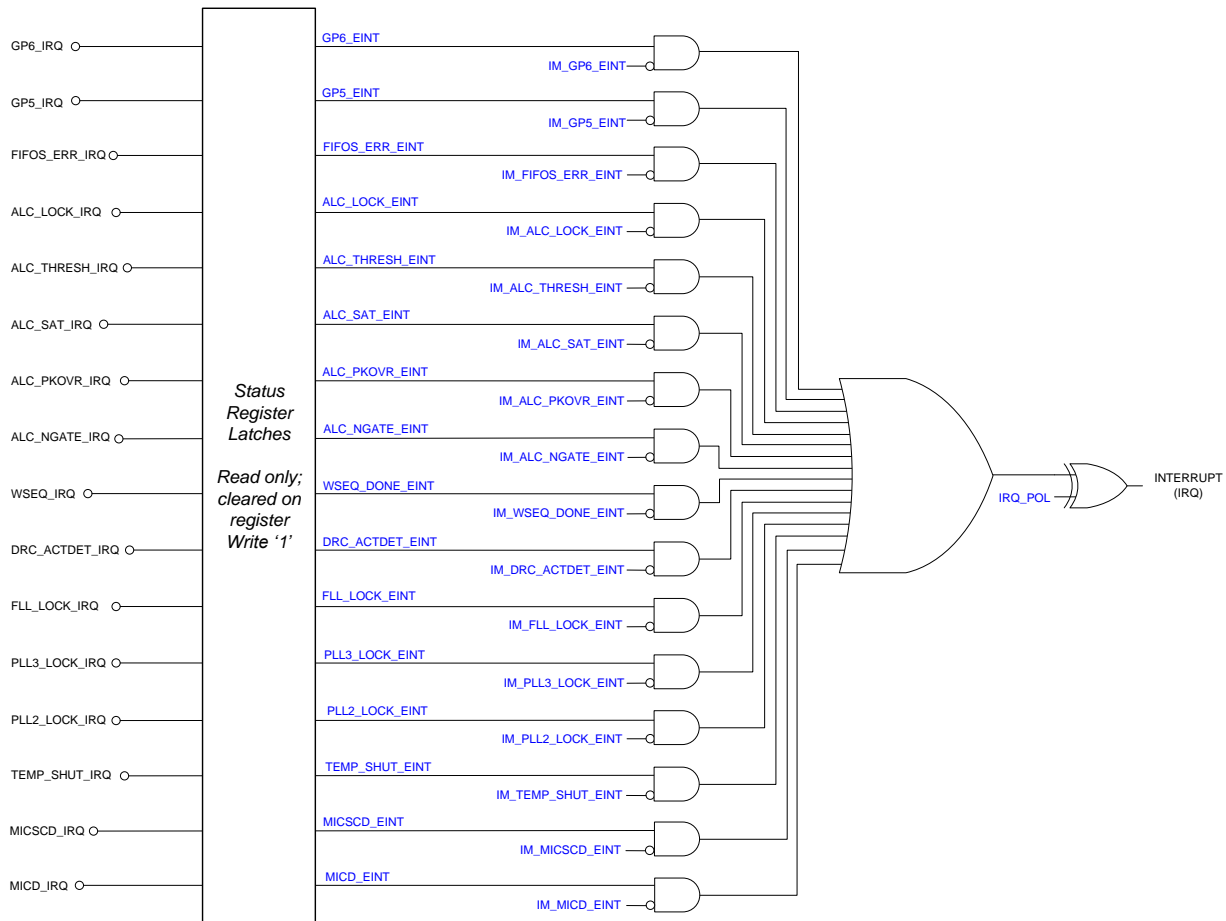

Figure 62 Interrupt Controller

REGISTER ADDRESS	BIT	LABEL	DEFAULT	DESCRIPTION
R560 (0230h) Interrupt Status 1	5	GP6_EINT	0	GPIO6 IRQ status 0 = GPIO6 IRQ not set 1 = GPIO6 IRQ set Note: cleared when a '1' is written
	4	GP5EINT	0	GPIO5 IRQ status 0 = GPIO5 IRQ not set 1 = GPIO5 IRQ set Note: cleared when a '1' is written
R561 (0231h) Interrupt Status 2	15	MICSCD_EINT	0	Mic Short Circuit Interrupt Status 0 = MICSCD IRQ not set 1 = MICSCD IRQ set Note: cleared when a '1' is written
	14	MICD_EINT	0	Mic Detect Interrupt Status 0 = MICD IRQ not set 1 = MICD IRQ set Note: cleared when a '1' is written
	13	FIFOS_ERR_EINT	0	FIFO error IRQ status 0 = FIFO error IRQ not set 1 = FIFO error IRQ set Note: cleared when a '1' is written
	12	ALC_LOCK_EINT	0	ALC level lock IRQ status 0 = ALC level lock IRQ not set 1 = ALC level lock IRQ set Note: cleared when a '1' is written
	11	ALC_THRESH_EINT	0	ALC level threshold IRQ status 0 = ALC level threshold IRQ not set 1 = ALC level threshold IRQ set Note: cleared when a '1' is written
	10	ALC_SAT_EINT	0	ALC saturation IRQ status 0 = ALC saturation IRQ not set 1 = ALC saturation IRQ set Note: cleared when a '1' is written
	9	ALC_PKOVR_EINT	0	ALC peak overload detector IRQ status 0 = ALC pk. overload det. IRQ not set 1 = ALC pk. Overload det. IRQ set Note: cleared when a '1' is written
	8	ALC_NGATE_EINT	0	ALC Noise Gate active IRQ status 0 = ALC Noise Gate IRQ not set 1 = ALC Noise Gate IRQ set Note: cleared when a '1' is written
	7	WSEQ_DONE_EINT	0	Write Sequencer done IRQ status 0 = Write Sequencer IRQ not set 1 = Write Sequencer IRQ set Note: cleared when a '1' is written
	6	DRC_ACTDET_EINT	0	DRC Activity IRQ status 0 = DRC Activity IRQ not set 1 = DRC Activity IRQ set Note: cleared when a '1' is written
	5	FLL_LOCK_EINT	0	FLL lock IRQ status 0 = FLL lock IRQ not set 1 = FLL lock IRQ set Note: cleared when a '1' is written

REGISTER ADDRESS	BIT	LABEL	DEFAULT	DESCRIPTION
	3	PLL3_LOCK_EI NT	0	PLL3 Lock IRQ status 0 = PLL3 Lock IRQ not set 1 = PLL3 Lock IRQ set Note: cleared when a '1' is written
	2	PLL2_LOCK_EI NT	0	PLL2 Lock IRQ status 0 = PLL2 Lock IRQ not set 1 = PLL2 Lock IRQ set Note: cleared when a '1' is written
	0	TEMP_SHUT_EI NT	0	Temperature Shutdown IRQ status 0 = Temperature Shutdown IRQ not set 1 = Temperature Shutdown IRQ set Note: cleared when a '1' is written
R568 (0238h) Interrupt Status 1 Mask	5	IM_GP6_EINT	1	Interrupt mask for GPIO6 0 = Not masked 1 = Masked
	4	IM_GP5_EINT	1	Interrupt mask for GPIO5 0 = Not masked 1 = Masked
R569 (0239h) Interrupt Status 2 Mask	15	IM_MICSCD_EI NT	0	Interrupt mask for Mic Short Circuit 0 = Not masked 1 = Masked
	14	IM_MICD_EINT	0	Interrupt mask for Mic Detect 0 = Not masked 1 = Masked
	13	IM_FIFOS_ERR _EINT	1	Interrupt mask for FIFOS Error 0 = Not masked 1 = Masked
	12	IM_ALC_LOCK_ EINT	1	Interrupt mask for ALC Lock 0 = Not masked 1 = Masked
	11	IM_ALC_THRES H_EINT	1	Interrupt mask for ALC Threshold 0 = Not masked 1 = Masked
	10	IM_ALC_SAT_EI NT	1	Interrupt mask for ALC Saturation 0 = Not masked 1 = Masked
	9	IM_ALC_PKOV R_EINT	1	Interrupt mask for ALC Peak Detector overload 0 = Not masked 1 = Masked
	8	IM_ALC_NGATE _EINT	1	Interrupt mask for ALC Noise Gate active 0 = Not masked 1 = Masked
	7	IM_WSEQ_DON E_EINT	1	Interrupt mask for Write Sequencer done 0 = Not masked 1 = Masked
	6	IM_DRC_ACTD ET_EINT	1	Interrupt mask for DRC Activity detect 0 = Not masked 1 = Masked
	5	IM_FLL_LOCK_ EINT	1	Interrupt mask for FLL Lock 0 = Not masked 1 = Masked

REGISTER ADDRESS	BIT	LABEL	DEFAULT	DESCRIPTION
	3	IM_PLL3_LOCK_EINT	1	Interrupt mask for PLL3 Lock 0 = Not masked 1 = Masked
	2	IM_PLL2_LOCK_EINT	1	Interrupt mask for PLL2 Lock 0 = Not masked 1 = Masked
	0	IM_TEMP_SHUT_EINT	1	Interrupt mask for Temperature Shutdown 0 = Not masked 1 = Masked
R576 (0240h) Interrupt Control	0	IRQ_POL	0	Interrupt Output polarity 0 = Active high 1 = Active low
R584 (0248h) IRQ Debounce	5	FLL_LOCK_DB	1	Debounce Enable on FLL Lock 0 = Disabled 1 = Enabled
	3	PLL3_LOCK_DB	1	Debounce Enable on PLL3 Lock 0 = Disabled 1 = Enabled
	2	PLL2_LOCK_DB	1	Debounce Enable on PLL2 Lock 0 = Disabled 1 = Enabled
	0	TEMP_SHUT_DB	1	Debounce Enable on Temperature Shutdown 0 = Disabled 1 = Enabled
R586 (024Ah) MICINT Source Pol	15	MICSCD_IRQ_POL	0	Mic Short Circuit Interrupt Polarity 0 = Active high (IRQ asserted when MICSHORT_THR is exceeded) 1 = Active low (IRQ asserted when MICSHORT_THR not exceeded)
	14	MICD_IRQ_POL	0	Mic Detect Interrupt Polarity 0 = Active high (IRQ asserted when MICDET_THR is exceeded) 1 = Active low (IRQ asserted when MICDET_THR not exceeded)

Table 120 Interrupt Control

CONTROL INTERFACE

The WM8962B is controlled by writing to its control registers. Readback is available for all registers. The Control Interface can operate as either a 2-, 3- or 4-wire interface:

- 2-wire (I2C) mode uses pins SCLK and SDA
- 3-wire (SPI) mode uses pins CS/GPIO6, SCLK and SDA
- 4-wire (SPI) mode uses the CS/GPIO6, SCLK and SDA pins; the SDOOUT function is provided on a GPIO pin

Readback is provided on the bi-directional pin SDA in 2-/3-wire modes. In 4-wire mode, the SDOOUT readback function must be enabled on one of the GPIO pins - see "General Purpose Input/Output (GPIO)".

In 3-wire and 4-wire SPI modes, the CS function is provided using the CS/GPIO6 pin. In these control interface modes, GPIO6 must be configured as CS by setting GP6_FN = 00h and GP6_DIR = 1. Note that this is the default setting of GPIO6.

The WM8962B uses 16-bit register addresses and 16-bit data in 2-wire (I2C) mode; the WM8962B uses 15-bit register addresses in 3-wire and 4-wire (SPI) modes.

The configuration parameters in registers R16896 (4200h) to R21139 (5293h) are 24-bit words, arranged within the 16-bit register address space. Each 24-bit word must be written to the register map in full, MSBs first, before attempting to read back the value. Failure to do this may give incorrect read/write behaviour.

When updating the configuration parameters for any DSP feature(s), it is recommended to write all of the associated registers, in incremental address order, before reading back any values.

Note that the Control Interface function can be supported with or without system clocking. Where possible, the register map access is synchronised with SYSCLK in order to ensure predictable operation of cross-domain functions. See "Clocking and Sample Rates" for further details of Control Interface clocking.

SELECTION OF CONTROL INTERFACE MODE

The WM8962B Control Interface Mode is determined by the logic level on the CIFMODE pin, as shown in Table 121.

CIFMODE	INTERFACE FORMAT
Low	2 wire (I2C) Mode
High	3- or 4- wire (SPI) Modes

Table 121 Control Interface Mode Selection

In 2-wire (I2C) Control Interface mode, Auto-Increment mode may be selected. This enables multiple write and multiple read operations to be scheduled faster than is possible with single register operations, and is illustrated in Figure 67, Figure 68 and Figure 69. The auto-increment option is enabled when the AUTO_INC register bit is set. This bit is defined in Table 122. Auto-increment is enabled by default.

In SPI modes, 3-wire or 4-wire operation may be selected using the SPI_4WIRE register bit.

In SPI modes, the Continuous Read mode may be selected using the SPI_CONTRD bit. This enables multiple register read operations to be scheduled faster than is possible with single register operations. When SPI_CONTRD is set, the WM8962B will readback from incremental register addresses as long as CS is held low and SCLK is toggled.

In 3-wire (SPI) mode, register readback is provided using the bi-directional pin SDA. During data output, the SDA pin can be configured as CMOS or Open Drain, using the SPI_CFG register bit.

In 4-wire (SPI) mode, register readback is provided using SDOOUT, which must be configured on one of the GPIO pins.

When GPIO5 is configured as SDOOUT, it may be configured as CMOS or as 'Wired OR' using the SPI_CFG bit. In CMOS mode, SDOOUT is driven low when not outputting register data. In 'Wired OR' mode, SDOOUT is un-driven (high impedance) when not outputting register data bits. Note that the

SDOUT function on GPIO2 and GPIO3 is not configurable using SPI_CFG; on these pins, SDOUT is a CMOS output at all times.

The Control Interface configuration bits are described in Table 122.

REGISTER ADDRESS	BIT	LABEL	DEFAULT	DESCRIPTION
R94 (005Eh) Control Interface	6	SPI_CONTRD	0	Enable continuous read mode in SPI (3-wire/4-wire) modes 0 = Disabled 1 = Enabled
	5	SPI_4WIRE	0	SPI control mode select 0 = 3-wire using bidirectional SDA 1 = 4-wire using SDOUT
	4	SPI_CFG	0	SDA/SDOUT pin configuration In 3-wire mode (SPI_4WIRE=0): 0 = SDA output is CMOS 1 = SDA output is Open Drain In 4-wire mode (SPI_4WIRE=1): 0 = SDOUT output is CMOS 1 = SDOUT output is Wired 'OR'. Note that only GPIO5 can be configured as Wired 'OR'. This bit has no effect on GPIO2 or GPIO3.
R252 (00FFh)	0	AUTO_INC	1	Enables address auto-increment (applies to 2-wire I2C mode only) 0 = Disabled 1 = Enabled

Table 122 Control Interface Configuration

2-WIRE (I2C) CONTROL MODE

In 2-wire (I2C) mode, the WM8962B is a slave device on the control interface; SCLK is a clock input, while SDA is a bi-directional data pin. To allow arbitration of multiple slaves (and/or multiple masters) on the same interface, the WM8962B transmits logic 1 by tri-stating the SDA pin, rather than pulling it high. An external pull-up resistor is required to pull the SDA line high so that the logic 1 can be recognised by the master.

In order to allow many devices to share a single 2-wire control bus, every device on the bus has a unique 8-bit device ID (this is not the same as the address of each register in the WM8962B). The WM8962B device ID is 0011_0100 (34h). The LSB of the device ID is the Read/Write bit; this bit is set to logic 1 for "Read" and logic 0 for "Write".

Important - in addition to the I2C address noted above (34h), the WM8962B also incorporates test functionality via I2C addresses 94h and D2h, and may respond to I2C operations at these addresses. It is a requirement that no other device on the same I2C bus makes use of address 94h or D2h.

The WM8962B operates as a slave device only. The controller indicates the start of data transfer with a high to low transition on SDA while SCLK remains high. This indicates that a device ID, register address and data will follow. The WM8962B responds to the start condition and shifts in the next eight bits on SDA (8-bit device ID, including Read/Write bit, MSB first). If the device ID received matches the device ID of the WM8962B, then the WM8962B responds by pulling SDA low on the next clock pulse (ACK). If the device ID is not recognised or the R/W bit is '1' when operating in write only mode, the WM8962B returns to the idle condition and waits for a new start condition and valid address.

If the device ID matches the device ID of the WM8962B, the data transfer continues as described below. The controller indicates the end of data transfer with a low to high transition on SDA while SCLK remains high. After receiving a complete address and data sequence the WM8962B returns to the idle state and waits for another start condition. If a start or stop condition is detected out of sequence at any point during data transfer (i.e. SDA changes while SCLK is high), the device returns to the idle condition.

The WM8962B supports the following read and write operations:

- Single write
- Single read
- Multiple write using auto-increment
- Multiple read using auto-increment

The sequence of signals associated with a single register write operation is illustrated in Figure 63.

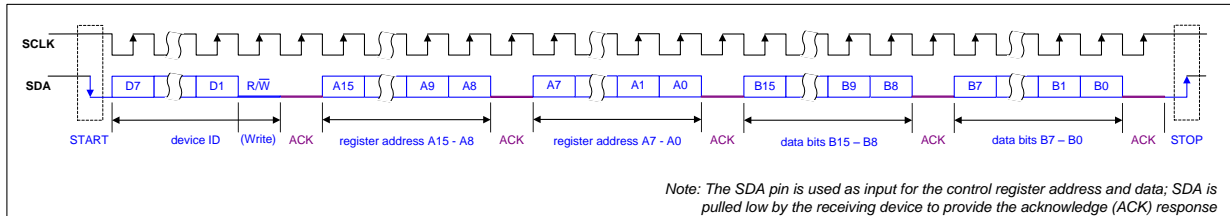

Figure 63 Control Interface 2-wire (I2C) Register Write

The sequence of signals associated with a single register read operation is illustrated in Figure 64.

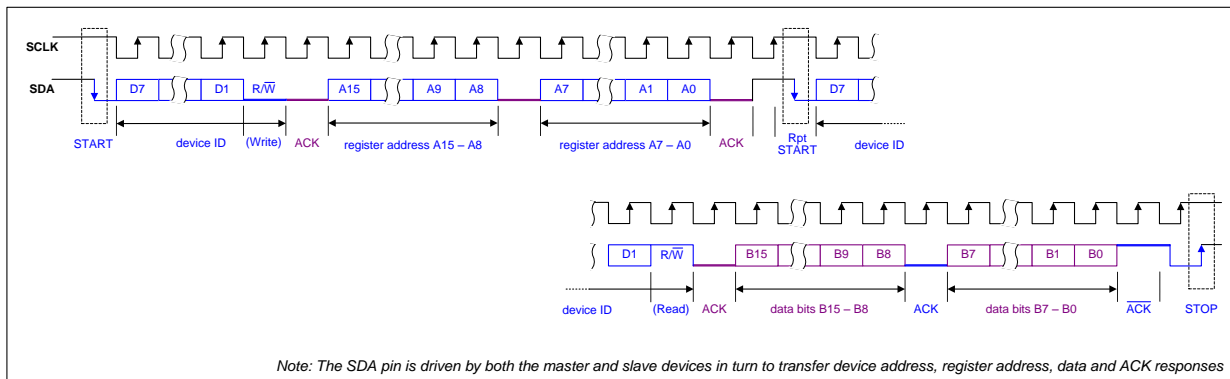

Figure 64 Control Interface 2-wire (I2C) Register Read

The Control Interface also supports other register operations, as listed above. The interface protocol for these operations is summarised below. The terminology used in the following figures is detailed in Table 123.

Note that, for multiple write and multiple read operations, the auto-increment option must be enabled. This feature is enabled by default, as noted in Table 122.

TERMINOLOGY	DESCRIPTION	
S	Start Condition	
Sr	Repeated start	
A	Acknowledge (SDA Low)	
\bar{A}	Not Acknowledge (SDA High)	
P	Stop Condition	
R/W	ReadNotWrite	0 = Write 1 = Read
[White field]	Data flow from bus master to WM8962B	
[Grey field]	Data flow from WM8962B to bus master	

Table 123 Control Interface Terminology

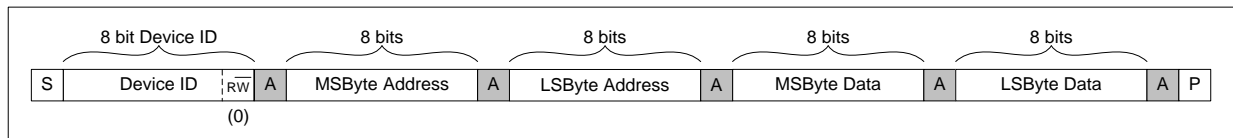

Figure 65 Single Register Write to Specified Address

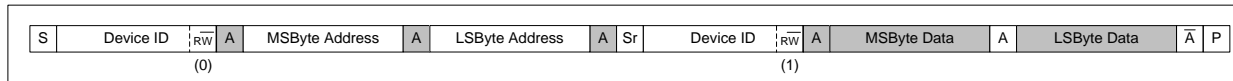

Figure 66 Single Register Read from Specified Address

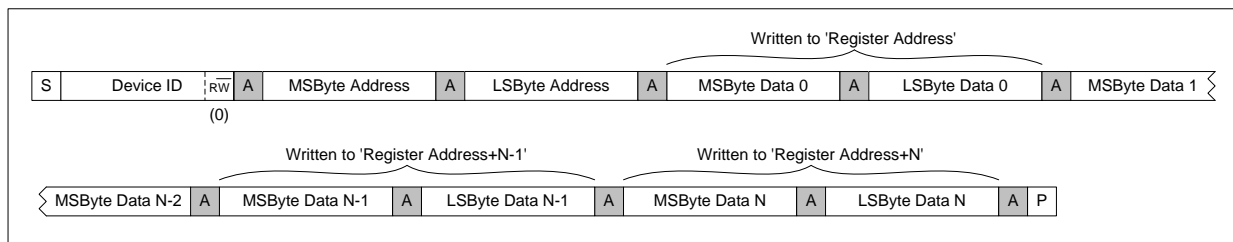

Figure 67 Multiple Register Write to Specified Address using Auto-increment

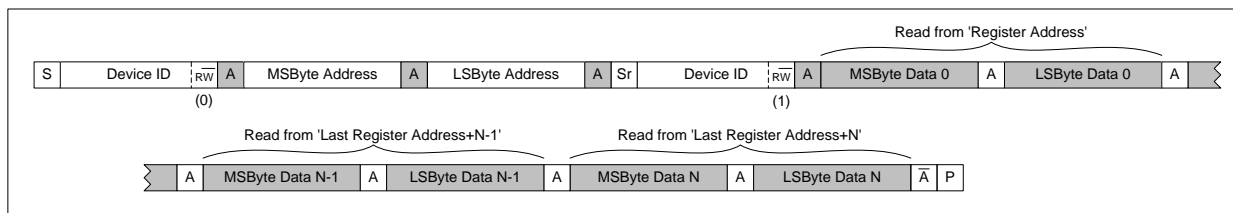

Figure 68 Multiple Register Read from Specified Address using Auto-increment

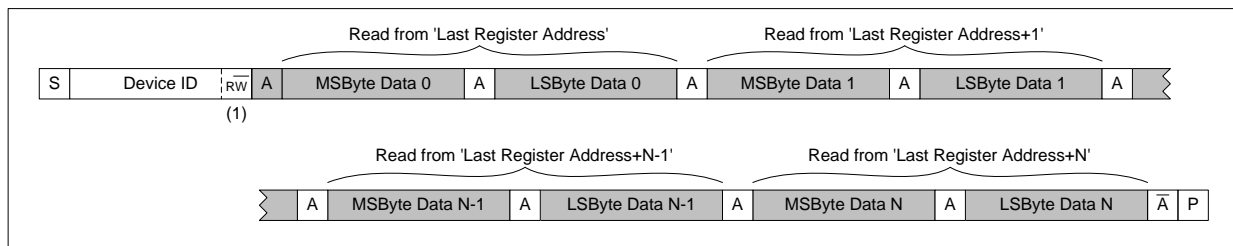

Figure 69 Multiple Register Read from Last Address using Auto-increment

Multiple Write and Multiple Read operations enable the host processor to access sequential blocks of the data in the WM8962B register map faster than is possible with single register operations. The auto-increment option is enabled when the AUTO_INC register bit is set. This bit is defined in Table 122. Auto-increment is enabled by default.

3-WIRE (SPI) CONTROL MODE

The 3-wire control interface uses the CS, SCLK and SDA pins.

In 3-wire control mode, a control word consists of 32 bits. The first bit is the read/write bit (R/W), which is followed by 15 address bits (A14 to A0) that determine which control register is accessed. The remaining 16 bits (B15 to B0) are data bits, corresponding to the 16 bits in each control register.

In 3-wire mode, every rising edge of SCLK clocks in one data bit from the SDA pin. A rising edge on CS latches in a complete control word consisting of the last 32 bits.

In Write operations (R/W=0), all SDA bits are driven by the controlling device.

In Read operations (R/W=1), the SDA pin is driven by the controlling device to clock in the register address, after which the WM8962B drives the SDA pin to output the applicable data bits.

During data output, the SDA pin can be configured as CMOS or Open Drain, using the SPI_CFG register bit, as described in Table 122. In Open Drain configuration, an external pull-up resistor is required to pull the SDA line high so that the logic 1 can be recognised by the master.

When SPI Continuous Read mode is enabled (SPI_CONTRD = 1), the WM8962B will readback from incremental register addresses as long as CS is held low and SCLK is toggled. In this mode, the WM8962B will increment the readback address after the first 32 clock cycles, and will output data from the next register address, and successive register addresses, MSB first, for as long as CS is held low and SCLK is toggled.

The 3-wire control mode timing is illustrated in Figure 70.

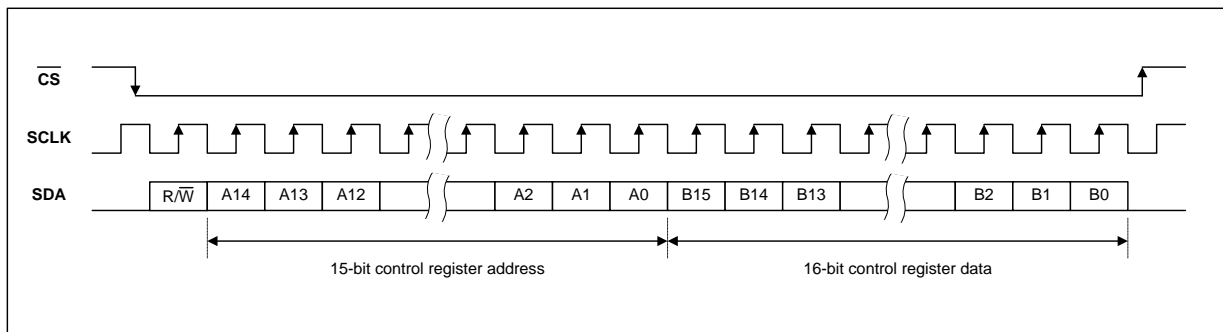

Figure 70 3-Wire Serial Control Interface

4-WIRE (SPI) CONTROL MODE

The 4-wire control interface uses the CS, SCLK, SDA and SDOUT pins.

The SDOUT function must be enabled on one of the GPIO pins - see "General Purpose Input/Output (GPIO)".

When GPIO5 is configured as the Data Output pin, SDOUT, it can be configured as CMOS or 'Wired OR', as described in Table 122. In CMOS mode, SDOUT is driven low when not outputting register data bits. In 'Wired OR' mode, SDOUT is undriven (high impedance) when not outputting register data bits. Note that the SDOUT function on GPIO2 and GPIO3 is not configurable using SPI_CFG; on these pins, SDOUT is a CMOS output at all times

In Write operations (R/W=0), this mode is the same as 3-wire mode described above.

In Read operations (R/W=1), the SDA pin is ignored following receipt of the valid register address. SDOUT is driven by the WM8962B.

When SPI Continuous Read mode is enabled (SPI_CONTRD = 1), the WM8962B will readback from incremental register addresses as long as CS is held low and SCLK is toggled. In this mode, the WM8962B will increment the readback address after the first 32 clock cycles, and will output data from the next register address, and successive register addresses, MSB first, for as long as CS is held low and SCLK is toggled.

The 4-wire control mode timing is illustrated in Figure 71 and Figure 72.

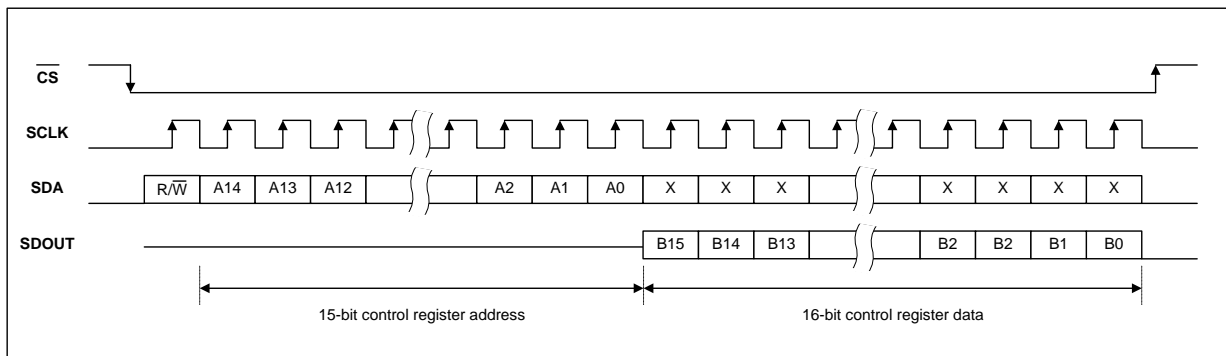

Figure 71 4-Wire Readback (CMOS)

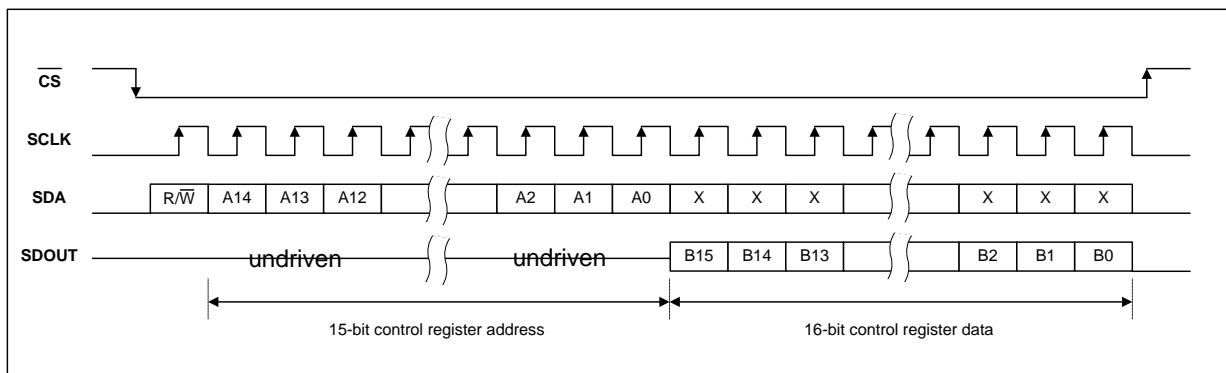

Figure 72 4-Wire Readback (Wired-'OR')

CONTROL WRITE SEQUENCER

The Control Write Sequencer is a programmable unit that forms part of the WM8962B control interface logic. It provides the ability to perform a sequence of register write operations with the minimum of demands on the host processor - the sequence may be initiated by a single operation from the host processor and then left to execute independently.

Default sequences for Start-Up of each output driver and Shut-Down are provided (see “Default Sequences” section). It is recommended that these default sequences are used unless changes become necessary.

When a sequence is initiated, the sequencer performs a series of pre-defined register writes. The host processor informs the sequencer of the start index of the required sequence within the sequencer’s memory. At each step of the sequence, the contents of the selected register fields are read from the sequencer’s memory and copied into the WM8962B control registers. This continues sequentially through the sequencer’s memory until an “End of Sequence” bit is encountered; at this point, the sequencer stops and an Interrupt status flag is asserted. For cases where the timing of the write sequence is important, a programmable delay can be set for specific steps within the sequence.

Note that the Control Write Sequencer’s internal clock is derived from the internal clock SYSCLK which must be enabled as described in “Clocking and Sample Rates”. The clock division from SYSCLK is handled transparently by the WM8962B without user intervention, provided that SYSCLK is configured as specified in “Clocking and Sample Rates”.

INITIATING A SEQUENCE

The Register fields associated with running the Control Write Sequencer are described in Table 124. Note that the operation of the Control Write Sequencer also requires the internal clock SYSCLK to be configured as described in “Clocking and Sample Rates”.

The Write Sequencer is enabled by setting the WSEQ_ENA bit. The start index of the required sequence must be written to the WSEQ_START_INDEX field.

The Write Sequencer stores up to 128 register write commands. These are defined in Registers R4096 to R4607. There are 4 registers used to define each of the 128 possible commands. The value of WSEQ_START_INDEX selects the registers applicable to the first write command in the selected sequence.

Setting the WSEQ_START bit initiates the sequencer at the given start index. The Write Sequencer can be interrupted by writing a logic 1 to the WSEQ_ABORT bit.

The current status of the Write Sequencer can be read using two further register fields - when the WSEQ_BUSY bit is asserted, this indicates that the Write Sequencer is busy. Note that, whilst the Control Write Sequencer is running a sequence (indicated by the WSEQ_BUSY bit), full read/write operations to the Control Registers cannot be supported. (Register access to the Control Write Sequencer registers, Software Reset registers, PLL/CLKOUT control registers is still supported while the Control Write Sequencer is running. Unsuccessful I2C interface commands will be indicated to the host processor by the WM8962B failing to provide the acknowledge, ‘ACK’, indication.)

The index of the current step in the Write Sequencer can be read from the WSEQ_CURRENT_INDEX field; this is an indicator of the sequencer’s progress. On completion of a sequence, this field holds the index of the last step within the last commanded sequence.

When the Write Sequencer reaches the end of a sequence, it asserts the WSEQ_DONE_EINT flag in Register R561 (see “Interrupts”). This flag can be used to generate an Interrupt Event on completion of the sequence. Note that the WSEQ_DONE_EINT flag is asserted to indicate that the WSEQ is NOT Busy.

The WM8962B supports the option to automatically power-down the Class D speaker drivers when the DAC Auto-Mute is triggered, and to re-enable the speaker drivers when audio data is detected. This is implemented using the Control Write Sequencer, and enabled by setting the WSEQ_AUTOSEQ_ENA bit. When this bit is set, and the conditions for DAC Auto-Mute are satisfied, the default “Speaker Sleep” sequence is triggered. When the DAC is un-muted following an Auto-Mute event, the “Speaker Wake” sequence is triggered. See “Default Sequences” for details of these sequences.

REGISTER ADDRESS	BIT	LABEL	DEFAULT	DESCRIPTION
R87 (57h) Write Sequencer Control 1	7	WSEQ_AUTOS EQ_ENA	0	Write Sequencer Auto-Sequence Enable (controls the Class D driver via DAC Auto-Mute function) 0 = Disabled 1 = Enabled
	5	WSEQ_ENA	0	Write Sequencer Enable. 0 = Disabled 1 = Enabled
R90 (5Ah) Write Sequencer Control 2	8	WSEQ_ABORT	0	Writing a 1 to this bit aborts the current sequence and returns control of the device back to the serial control interface.
	7	WSEQ_START	0	Writing a 1 to this bit starts the write sequencer at the index location selected by WSEQ_START_INDEX. The sequence continues until it reaches an "End of sequence" flag. At the end of the sequence, this bit will be reset by the Write Sequencer.
	6:0	WSEQ_START_INDEX [6:0]	000_0000	Sequence Start Index. This field determines the memory location of the first command in the selected sequence. There are 127 Write Sequencer RAM addresses: 00h = WSEQ_ADDR0 (R4096) 01h = WSEQ_ADDR1 (R4100) 02h = WSEQ_ADDR2 (R4104) 7Fh = WSEQ_ADDR127 (R4604)
R93 (5Dh) Write Sequencer Control 3	9:3	WSEQ_CURRENT_INDEX [6:0] (read only)	000_0000	Sequence Current Index. This indicates the memory location of the most recently accessed command in the write sequencer memory. Coding is the same as WSEQ_START_INDEX.
	0	WSEQ_BUSY (read only)	0	Sequencer Busy flag (Read Only). 0 = Sequencer idle 1 = Sequencer busy Note: it is not possible to write to control registers via the control interface while the Sequencer is Busy.

Table 124 Write Sequencer Control - Initiating a Sequence

PROGRAMMING A SEQUENCE

A sequence consists of write operations to data bits (or groups of bits) within the control registers. Each write operation is defined by a block of 4 registers, which contain 6 fields as described in this section.

The block of 4 registers is the same for up to 128 steps held in the sequencer memory. Multiple sequences can be held in the memory at the same time; each sequence occupies its own range within the 128 available register blocks.

The following 6 fields are replicated 128 times - one for each of the sequencer's 128 steps. In the following descriptions, the term 'n' is used to denote the step number, from 0 to 127.

WSEQ_ADDRn is a 14-bit field containing the Control Register Address in which the data should be written. Note that the Control Write Sequencer cannot be used to access the Software Reset registers, PLL/CLKOUT control registers or the Write Sequencer registers R87, R90 and R93.

WSEQ_DATA n is an 8-bit field which contains the data to be written to the selected Control Register. The WSEQ_DATA_WIDTH n field determines how many of these bits are written to the selected register; the most significant bits (above the number indicated by WSEQ_DATA_WIDTH n) are ignored.

WSEQ_DATA_START n is a 4-bit field which identifies the LSB position within the selected Control Register to which the data should be written. For example, setting WSEQ_DATA_START n = 0100 will select bit 4 as the LSB position; in this case, 4-bit data would be written to bits 7:4.

WSEQ_DATA_WIDTH n is a 3-bit field which identifies the width of the data block to be written. This enables selected portions of a Control Register to be updated without any concern for other bits within the same register, eliminating the need for read-modify-write procedures. Values of 0 to 7 correspond to data widths of 1 to 8 respectively. For example, setting WSEQ_DATA_WIDTH n = 010 will cause a 3-bit data block to be written. Note that the maximum value of this field corresponds to an 8-bit data block; writing to register fields greater than 8 bits wide must be performed using two separate operations of the Control Write Sequencer.

WSEQ_DELAY n is a 4-bit field which controls the waiting time between the current step and the next step in the sequence i.e. the delay occurs after the write in which it was called. The total delay time per step (including execution) is defined below, giving a useful range of execution/delay times from approximately 562 μ s up to 2.048s per step:

$$T = k \times (2^{WSEQ_DELAY} + 8)$$

where $k = 62.5\mu\text{s}$ (if SAMPLE_RATE_INT_MODE = 1)

and $k = 68.1\mu\text{s}$ (if SAMPLE_RATE_INT_MODE = 0)

Note that the sequencer execution/delay time varies between integer and fractional values of the SAMPLE_RATE register; see "Clocking and Sample Rates" for details of the associated registers.

WSEQ_EOS n is a 1-bit field which indicates the End of Sequence. If this bit is set, then the Control Write Sequencer will automatically stop after this step has been executed.

The register definitions for Step 0 are described in Table 125. The equivalent definitions also apply to Step 1 through to Step 127, in the subsequent register address locations.

REGISTER ADDRESS	BIT	LABEL	DEFAULT	DESCRIPTION
R4096 (1000h) Write Sequencer 0	13:0	WSEQ_ADDR 0 [13:0]	001Ch	Control Register Address to be written to in this sequence step.
R4097 (1001h) Write Sequencer 1	7:0	WSEQ_DATA 0 [7:0]	03h	Data to be written in this sequence step. When the data width is less than 8 bits, then one or more of the MSBs of WSEQ_DATA n are ignored. It is recommended that unused bits be set to 0.
R4098 (1002h) Write Sequencer 2	10:8	WSEQ_DATA_WIDTH0 [2:0]	001	Width of the data block written in this sequence step. 000 = 1 bit 001 = 2 bits 010 = 3 bits 011 = 4 bits 100 = 5 bits 101 = 6 bits 110 = 7 bits 111 = 8 bits
	3:0	WSEQ_DATA_START0 [3:0]	0011	Bit position of the LSB of the data block written in this sequence step. 0000 = Bit 0 ... 1111 = Bit 15

REGISTER ADDRESS	BIT	LABEL	DEFAULT	DESCRIPTION
R4099 (1003h) Write Sequencer 3	8	WSEQ_EOS0	0	End of Sequence flag. This bit indicates whether the Control Write Sequencer should stop after executing this step. 0 = Not end of sequence 1 = End of sequence (Stop the sequencer after this step).
	3:0	WSEQ_DELAY0 [3:0]	0000	Time delay after executing this step. Total time per step (including execution) = $k \times (2^{WSEQ_DELAY} + 8)$. $k = 62.5\mu\text{s}$ (SAMPLE_RATE_INT_MODE = 1), $k = 68.1\mu\text{s}$ (SAMPLE_RATE_INT_MODE = 0),

Table 125 Write Sequencer Control - Programming a Sequence

Note that a 'Dummy' write can be inserted into a control sequence by commanding the sequencer to write a value of 0 to bit 0 of Register R254 (00FEh). This is effectively a write to a non-existent register location. This can be used in order to create placeholders ready for easy adaptation of a control sequence. For example, a sequence could be defined to power-up a mono signal path from DACL to headphone, with a 'dummy' write included to leave space for easy modification to a stereo signal path configuration. Dummy writes can also be used in order to implement additional time delays between register writes.

In summary, the Control Register to be written is set by the WSEQ_ADDR n field. The data bits that are written are determined by a combination of WSEQ_DATA_START n , WSEQ_DATA_WIDTH n and WSEQ_DATA n . This is illustrated below for an example case of writing to the DAC_DEEMP field within Register R5 (0005h).

In this example, the Start Position is bit 01 (WSEQ_DATA_START n = 0001b) and the Data width is 2 bits (WSEQ_DATA_WIDTH n = 0001b). With these settings, the Control Write Sequencer would update the Control Register R5 [2:1] with the contents of WSEQ_DATA n [1:0].

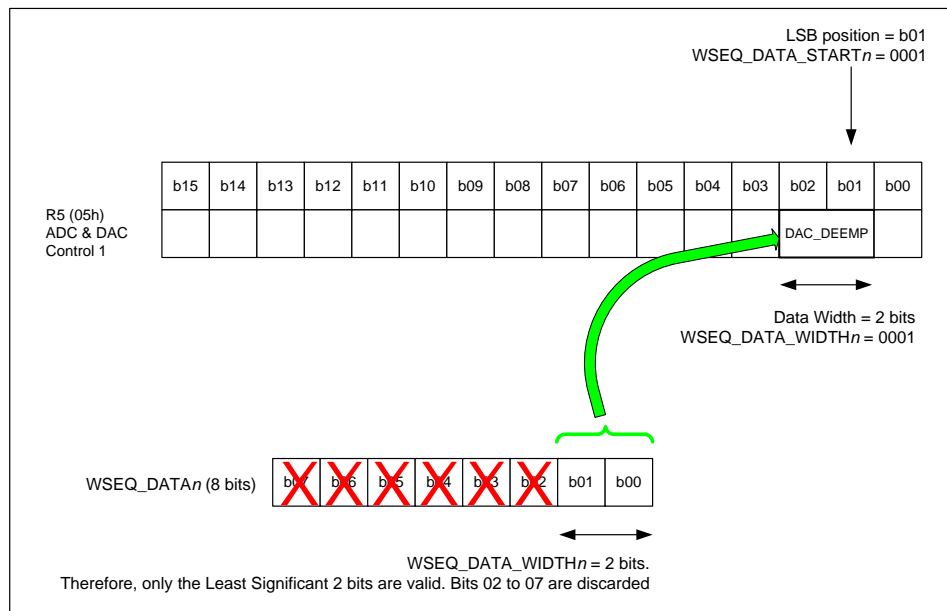
Figure 73 Control Write Sequencer Example

DEFAULT SEQUENCES

When the WM8962B is powered up, a number of Control Write Sequences are available through default settings in the sequencer memory locations. The pre-programmed default settings include Start-Up and Shut-Down sequences for each of the output drivers. Note that the default sequences do not include audio signal path or gain setting configuration; this must be implemented prior to scheduling any of the default Start-Up sequences.

The entire sequencer memory may be programmed to users' own settings at any time, as described in "Programming a Sequence". Users' own settings remain in memory regardless of WSEQ_ENA, and are not affected by software resets (i.e. writing to Register R15). However, any non-default sequences are lost when the device is powered down.

The following default control sequences are provided:

1. DAC to Headphone Power Up - This sequence powers up the HPOUT headphone driver and charge pump. It commands the DC Servo to perform offset correction. It enables the master bias required for analogue functions. This sequence is intended for enabling the headphone output after initial power-on.
2. Analogue Input Power Up - This sequence powers up the analogue input (IN1L and IN1R) signal paths to the ADC output. The MICBIAS is enabled for powering electret condenser microphones connected to IN1L and IN1R. The DC Servo performs offset correction on the input signal paths. The intended usage of this sequence assumes that the "DAC to Headphone 1 Power Up" sequence has been run previously.
3. Chip Power Down - This sequence shuts down all of the WM8962B input paths, output drivers, DC Servo, charge pump and analogue bias circuits.
4. Speaker Sleep - This sequence mutes the DAC output and Class D speaker output, and disabled the Class D output driver. This is intended for use as a power saving feature during quiescent DAC conditions. When the WSEQ_AUTOSEQ_ENA register bit is set, this sequence is automatically triggered whenever quiescent DAC playback conditions are detected.
5. Speaker Wake - This sequence enables the Class D speaker driver output and un-mutes the DAC output and Class D speaker path. When the WSEQ_AUTOSEQ_ENA register bit is set, this sequence is automatically triggered whenever a non-zero DAC sample is detected following an AUTOMUTE event.

Specific details of each of these sequences is provided below.

DAC to Headphone Power Up

The DAC to Headphone Power Up sequence is initiated by writing 0080h to Register 90 (5Ah). This single operation starts the Control Write Sequencer at Index Address 0 (00h).

This sequence takes up to 93ms to run.

WSEQ INDEX	REGISTER ADDRESS	WIDTH	START	DATA	DELAY	EOS	DESCRIPTION
0 (00h)	R28 (1Ch)	2 bits	Bit 3	03h	0h	0b	STARTUP_BIAS_ENA = 1b VMID_BUF_ENA = 1b
1 (01h)	R25 (19h)	3 bits	Bit 6	07h	0h	0b	VMID_SEL [1:0] = 11b BIAS_ENA = 1b
2 (02h)	R72 (48h)	1 bit	Bit 0	01b	6h	0b	CP_ENA = 1b (time delay inserted)
3 (03h)	R26 (1Ah)	4 bits	Bit 5	0Fh	0h	0b	DACL_ENA = 1b DACR_ENA = 1b HPOUTL_PGA_ENA = 1b HPOUTR_PGA_ENA = 1b
4 (04h)	R69 (45h)	5 bits	Bit 0	11h	0h	0b	HP1L_ENA = 1b HP1R_ENA = 1b
5 (05h)	R69 (45h)	5 bits	Bit 1	19h	0h	0b	HP1L_ENA_DLY = 1b HP1R_ENA_DLY = 1b
6 (06h)	R2 (2h)	7 bits	Bit 0	30h	0h	0b	HPOUTL_VOL [6:0] = 30h
7 (07h)	R3 (3h)	7 bits	Bit 0	30h	0h	0b	HPOUTR_VOL [6:0] = 30h
8 (08h)	R3 (3h)	1 bit	Bit 8	01h	0h	0b	HPOUT_VU = 1b
9 (09h)	R61 (3Dh)	6 bits	Bit 2	33h	Ah	0b	HP1L_DCS_ENA = 1b HP1L_DCS_STARTUP = 1b HP1R_DCS_ENA = 1b HP1R_DCS_STARTUP = 1b (time delay inserted)
10 (0Ah)	R254 (FEh)	1 bit	Bit 0	00h	0h	0b	Dummy Write for expansion
11 (0Bh)	R7 (7h)	2 bits	Bit 2	00h	0h	0b	WL [1:0] = 00
12 (0Ch)	R69 (45h)	5 bits	Bit 2	1Dh	0h	0b	HP1L_ENA_OUTP = 1 HP1R_ENA_OUTP = 1
13 (0Dh)	R69 (45h)	5 bits	Bit 3	1Fh	0h	0b	HP1L_RMV_SHORT = 1 HP1R_RMV_SHORT = 1
14 (0Eh)	R254 (FEh)	1 bit	Bit 0	00h	0h	0b	Dummy Write for expansion
15 (0Fh)	R5 (5h)	1 bit	Bit 3	00h	7h	1b	DAC_MUTE = 0 (time delay inserted)

Table 126 DAC to Headphone 1 Power Up Sequence

Analogue Input Power Up

The Analogue Input Power Up sequence is initiated by writing 0092h to Register 90 (5Ah). This single operation starts the Control Write Sequencer at Index Address 18 (12h).

This sequence takes up to 75ms to run.

WSEQ INDEX	REGISTER ADDRESS	WIDTH	START	DATA	DELAY	EOS	DESCRIPTION
18 (12h)	R32 (20h)	3 bits	Bit 3	07h	0h	0b	INPGAL_MIXINL_VOL [2:0] = 111b
19 (13h)	R33 (21h)	3 bits	Bit 3	07h	0h	0b	INPGAR_MIXINR_VOL [2:0] = 111b
20 (14h)	R25 (19h)	5 bits	Bit 1	19h	0h	0b	INL_ENA = 1 INR_ENA = 1 MICBIAS_ENA = 1

WSEQ INDEX	REGISTER ADDRESS	WIDTH	START	DATA	DELAY	EOS	DESCRIPTION
21 (15h)	R60 (3Ch)	6 bits	Bit 2	33h	Ah	0b	INL_DCS_ENA = 1 INL_DCS_STARTUP = 1 INR_DCS_ENA = 1 INR_DCS_STARTUP = 1 (time delay inserted)
22 (16h)	R254 (FEh)	1 bit	Bit 0	00h	0h	0b	Dummy Write for expansion
23 (17h)	R25 (19h)	2 bits	Bit 2	03h	0h	0b	ADCL_ENA = 1 ADCR_ENA = 1
24 (18h)	R32 (20h)	3 bits	Bit 3	00h	0h	0b	INPGAL_MIXINL_VOL [2:0] = 000
25 (19h)	R33 (21h)	3 bits	Bit 3	00h	0h	1b	INPGAR_MIXINR_VOL [2:0] = 000

Table 127 Analogue Input Power Up Sequence
Chip Power Down

The Chip Power Down sequence is initiated by writing 009Bh to Register 90 (5Ah). This single operation starts the Control Write Sequencer at Index Address 27 (1Bh).

This sequence takes up to 32ms to run.

WSEQ INDEX	REGISTER ADDRESS	WIDTH	START	DATA	DELAY	EOS	DESCRIPTION
27 (1Bh)	R5 (5h)	1 bit	Bit 3	01h	8h	0b	DAC_MUTE = 1b (time delay inserted)
28 (1Ch)	R0 (0h)	1 bit	Bit 7	01h	0h	0b	INPGAL_MUTE = 1b
29 (1Dh)	R1 (1h)	2 bits	Bit 7	03h	0h	0b	INVU = 1b INPGAR_MUTE = 1b
30 (1Eh)	R69 (45h)	5 bits	Bit 3	0Eh	0h	0b	HP1L_RMV_SHORT = 0b HP1R_RMV_SHORT = 0b
31 (1Fh)	R96 (60h)	5 bits	Bit 3	0Eh	0h	0b	
32 (20h)	R2 (2h)	7 bits	Bit 0	00h	0h	0b	HPOUTL_VOL [6:0] = 00h
33 (21h)	R3 (3h)	7 bits	Bit 0	00h	0h	0b	HPOUTR_VOL [6:0] = 00h
34 (22h)	R3 (3h)	1 bit	Bit 8	01h	0h	0b	HPOUTVU = 1b
35 (23h)	R40 (28h)	7 bits	Bit 0	00h	0h	0b	SPKOUTL_VOL [6:0] = 00h
36 (24h)	R41 (29h)	7 bits	Bit 0	00h	0h	0b	SPKOUTR_VOL [6:0] = 00h
37 (25h)	R41 (29)	1 bit	Bit 8	01h	0h	0b	SPKOUT_VU = 1b
38 (26h)	R60 (3Ch)	5 bits	Bit 3	00h	0h	0b	INL_DCS_ENA = 0b INR_DCS_ENA = 0b
39 (27h)	R61 (3Dh)	5 bits	Bit 3	00h	0h	0b	HP1L_DCS_ENA = 0b HP1R_DCS_ENA = 0b
40 (28h)	R62 (3Eh)	5 bits	Bit 3	00h	0h	0b	
41 (29h)	R69 (45h)	8 bits	Bit 0	00h	0h	0b	HP1L_ENA_OUTP = 0b HP1L_ENA_DLY = 0b HP1L_ENA = 0b HP1R_ENA_OUTP = 0b HP1R_ENA_DLY = 0b HP1R_ENA = 0b
42 (2Ah)	R96 (60h)	8 bits	Bit 0	00h	0h	0b	
43 (2Bh)	R49 (31h)	2 bits	Bit 6	00h	0h	0b	SPKOUTR_ENA = 0b SPKOUTL_ENA = 0b
44 (2Ch)	R99 (63h)	4 bits	Bit 0	00h	0h	0b	HPMIXL_ENA = 0b HPMIXR_ENA = 0b SPKMIXL_ENA = 0b SPKMIXR_ENA = 0b

WSEQ INDEX	REGISTER ADDRESS	WIDTH	START	DATA	DELAY	EOS	DESCRIPTION
45 (2Dh)	R26 (1Ah)	6 bits	Bit 3	00h	0h	0b	DACL_ENA = 0b DACR_ENA = 0b HPOUTL_PGA_ENA = 0b HPOUTR_PGA_ENA = 0b SPKOUTL_PGA_ENA = 0b SPKOUTR_PGA_ENA = 0b
46 (2Eh)	R72 (48h)	1 bit	Bit 0	00h	0h	0b	CP_ENA = 0b
47 (2Fh)	R25 (19h)	6 bits	Bit 1	00h	0h	0b	BIAS_ENA = 0b INL_ENA = 0b INR_ENA = 0b ADCL_ENA = 0b ADCR_ENA = 0b MICBIAS_ENA = 0b
48 (30h)	R28 (1Ch)	2 bits	Bit 3	00h	0h	0b	STARTUP_BIAS_ENA = 0b VMID_BUF_ENA = 0b
49 (31h)	R25 (19h)	2 bits	Bit 7	00h	0h	1b	VMID_SEL [1:0] = 00b

Table 128 Chip Power Down Sequence
Speaker Sleep

The Speaker Sleep sequence is initiated by writing 00E4h to Register 90 (5Ah). This single operation starts the Control Write Sequencer at Index Address 100 (64h).

This sequence takes up to 2ms to run.

WSEQ INDEX	REGISTER ADDRESS	WIDTH	START	DATA	DELAY	EOS	DESCRIPTION
100 (64h)	R49 (31h)	1 bit	Bit 4	01h	0h	0b	DAC_MUTE = 1
101 (65h)	R49 (31h)	3 bits	Bit 0	07h	0h	0b	SPKOUT_VU = 1 SPKOUTL_PGA_MUTE = 1 SPKOUTR_PGA_MUTE = 1
102 (66h)	R49 (31h)	2 bits	Bit 6	00h	0h	1b	SPKOUTR_ENA = 0 SPKOUTL_ENA = 0

Table 129 Speaker Sleep Sequence
Speaker Wake

The Speaker Wake sequence is initiated by writing 00E8h to Register 90 (5Ah). This single operation starts the Control Write Sequencer at Index Address 104 (68h).

This sequence takes up to 2ms to run.

WSEQ INDEX	REGISTER ADDRESS	WIDTH	START	DATA	DELAY	EOS	DESCRIPTION
104 (68h)	R49 (31h)	2 bits	Bit 6	03h	0h	0b	SPKOUTR_ENA = 1 SPKOUTL_ENA = 1
105 (69h)	R49 (31h)	3 bits	Bit 0	04h	0h	0b	SPKOUT_VU = 1 SPKOUTL_PGA_MUTE = 0 SPKOUTR_PGA_MUTE = 0
106 (6Ah)	R49 (31h)	1 bit	Bit 4	00h	0h	1b	DAC_MUTE = 0

Table 130 Speaker Wake Sequence

THERMAL SHUTDOWN

The WM8962B incorporates a temperature sensor on each of the headphone circuit and the speaker circuit. These detect when the device temperature is within normal limits, or the device is approaching a hazardous temperature condition (above 125°C and below 145°C), or if the device has exceeded a hazardous temperature condition (>145°C). The temperature sensors can be configured to automatically disable the audio outputs of the WM8962B in response to an over-temperature condition (approximately 145°C) on either the headphone or the speaker circuits.

The temperature status can be output directly on a GPIO pin, as described in the “General Purpose Input/Output (GPIO)” section. The temperature sensor can also be used to generate Interrupt events, as described in the “Interrupts” section.

The temperature sensors are enabled on the headphone and the speaker circuits by setting the TEMP_ENA_HP and the TEMP_ENA_SPK register bits respectively.

Temperature warnings are flagged at 125°C by asserting the TEMP_WARN_HP (headphones) and TEMP_WARN_SPK (speakers) register bits. Potentially hazardous over-temperature conditions are flagged by the setting of the TEMP_ERR_HP (headphones) and TEMP_ERR_SPK (speakers) registers.

When the THERR_ACT register is also set, then a device over-temperature condition in either sensor (TEMP_ERR_HP or TEMP_ERR_SPK asserted) will cause the speaker outputs (SPKOUTL and SPKOUTR) to be disabled by setting SPKL_ENA and SPKR_ENA to 0, and the headphone outputs to be disabled by setting CP_ENA to 0. This response is likely to prevent any damage to the device attributable to the large currents of the output drivers. Note that headphone and speaker audio outputs are both disabled when either of the TEMP_ERR_HP or TEMP_ERR_SPK register bits is set.

When the audio circuits are disabled by THERR_ACT after reaching a temperature of 145°C, they will be reset to their previous setting once the temperature drops again.

REGISTER ADDRESS	BIT	LABEL	DEFAULT	DESCRIPTION
R23 (17h) Additional control(1)	8	THERR_ACT [15:0]	1	Speaker and Headphone over-temperature shutdown enable. 0 = Disabled 1 = Enabled Note that TEMP_ENA_HP or TEMP_ENA_SPK or both must be enabled for Automatic Shutdown to work
R47 (2Fh) Thermal Shutdown Status	3	TEMP_ERR_HP	0	Headphone temperature error status (triggered at 145°C) 0 = Not triggered 1 = Triggered Note that this is a Read Only field
	2	TEMP_WARN_HP	0	Headphone temperature warning status (triggered at 125°C) 0 = Not triggered 1 = Triggered Note that this is a Read Only field
	1	TEMP_ERR_SPK	0	Speaker temperature error status (triggered at 145°C) 0 = Not triggered 1 = Triggered Note that this is a Read Only field
	0	TEMP_WARN_SPK	0	Speaker temperature warning status (triggered at 125°C) 0 = Not triggered 1 = Triggered Note that this is a Read Only field
R48 (30h)	2	TEMP_ENA_HP	1	Headphone temperature sensor enable 0 = Disabled 1 = Enabled

REGISTER ADDRESS	BIT	LABEL	DEFAULT	DESCRIPTION
	1	TEMP_ENA_S PK	1	Speaker temperature sensor enable 0 = Disabled 1 = Enabled

Table 131 Temperature Sensor Control

SOFTWARE RESET AND CHIP ID

A Software Reset can be commanded by writing to Register R15. This is a read-only register field and the contents will not be affected by writing to this Register. Note that the PLL Registers (R114 through to R152) are not affected by this Software Reset; these registers can be reset separately.

A PLL Software Reset can be commanded by writing to Register R127. This is a read-only register field and the contents will not be affected by writing to this Register. The PLL Software Reset causes the contents of the PLL Registers (R114 through to R152) to be reset to their default states.

The Customer ID and Chip Revision ID can be read back from Register R1 (01h), as described in Table 132.

REGISTER ADDRESS	BIT	LABEL	DEFAULT	DESCRIPTION
R1 (01h) Right Input volume	15:12	CUST_ID [3:0]	0000b	Reading from this register will indicate the Customer ID.
	11:9	CHIP_REV [2:0]		Reading from this register will indicate the Chip Revision ID. 000 = Rev A 001 = Rev B 010 = Rev C 011 = Rev D
R15 (0Fh) Software Reset	15:0	SW_RESET [15:0]	6243h	Writing to this register resets all non-PLL registers to their default state. Registers R114 (72h) through to R152 (98h) are not affected by this Reset. Reading from this register will indicate Chip ID 6243h.
R127 (7Fh) PLL Software Reset	15:0	SW_RESET_ PLL [15:0]		Writing to this register resets all PLL registers to their default state. This affects registers R114 (72h) through to R152 (98h).

Table 132 Software Reset and Chip ID

REGISTER MAP

The WM8962B control registers are listed below. Note that only the register addresses described here should be accessed; writing to other addresses may result in undefined behaviour. Register bits that are not documented should not be changed from the default values.

REG	NAME	15	14	13	12	11	10	9	8	7	6	5	4	3	2	1	0	DEFAULT	
R0 (0h)	Left Input volume	0	0	0	0	0	0	0	IN_VU	INPGA_L_MUTE	INL_ZC	INL_VOL [5:0]					009Fh		
R1 (1h)	Right Input volume	CUST_ID [3:0]			CHIP_REV [2:0]			IN_VU	INPGA_R_MUTE	INR_ZC	INR_VOL [5:0]					069Fh			
R2 (2h)	HPOUTL volume	0	0	0	0	0	0	0	HPOUT_VU	HPOUT_L_ZC	HPOUTL_VOL [6:0]					0000h			
R3 (3h)	HPOUTR volume	0	0	0	0	0	0	0	HPOUT_VU	HPOUT_R_ZC	HPOUTR_VOL [6:0]					0000h			
R4 (4h)	Clocking1	0	0	0	0	0	DSPCLK_DIV [1:0] (K)		ADCSYS_CLK_DIV [2:0] (K)		DACSYS_CLK_DIV [2:0] (K)		SYSCLK_DIV [1:0] (K)		0	0020h			
R5 (5h)	ADC & DAC Control 1	0	0	0	0	0	0	0	0	0	ADCR_DAT_I NV	ADCL_DAT_I NV	DAC_MUTE_R AMP	DAC_MUTE	DAC_DEEMP [1:0]		ADC_HPF_DIS	0018h	
R6 (6h)	ADC & DAC Control 2	0	0	ADC_HPF_SR [1:0] (K)		0	ADC_HPF_MODE	ADC_HPF_CUT [2:0]		DACR_DAT_I NV	DACL_DAT_I NV	0	DAC_UNMUTE_RAM_P	DAC_MUTE	0	DAC_HP	2008h		
R7 (7h)	Audio Interface 0	0	0	0	AIFDACC_TDM_MOD_E	AIFDACC_TDM_SLOT	AIFDACC_TDM_MOD_E	AIFDACC_TDM_SLOT	ADC_LRSWA_P	BCLK_I NV	MSTR	DAC_LRSWA_P	LRCLK_INV	WL [1:0]		FMT [1:0]		000Ah	
R8 (8h)	Clocking2	0	0	0	0	CLKREG_OVD	MCLK_SRC [1:0]		CLASSD_CLK_DIV [2:0] (K)		SYSCLK_ENA	0	BCLK_DIV [3:0]			01E4h			
R9 (9h)	Audio Interface 1	0	0	0	0	AUTOMUTE_STS	0	DAC_AUTOMUTE_SAMPLES [1:0]		DAC_AUTOMUTE	0	0	DAC_COMP	DAC_COMPMODE	ADC_COMP	ADC_COMPMODE	LOOPBACK	0300h	
R10 (Ah)	Left DAC volume	0	0	0	0	0	0	0	DAC_VU	DACL_VOL [7:0]							00C0h		
R11 (Bh)	Right DAC volume	0	0	0	0	0	0	0	DAC_VU	DACR_VOL [7:0]							00C0h		
R14 (Eh)	Audio Interface 2	0	0	0	0	0	AIF_RATE [10:0]										0040h		
R15 (Fh)	Software Reset	SW_RESET [15:0]																0000h	
R17 (11h)	ALC1	0	0	0	0	0	ALC_INACTIVE_ENA	ALC_LVL_MODE	ALC_L_ENA	ALC_R_ENA	ALC_MAXGAIN [2:0]		ALC_LVL [3:0]			007Bh			
R18 (12h)	ALC2	ALC_LOCK_STS	ALC_THRESH_STS	ALC_SAT_STS	ALC_PKOVR_STS	ALC_NGATE_STS	0	0	0	ALC_ZC	ALC_MINGAIN [2:0]		ALC_HLD [3:0]			0000h			
R19 (13h)	ALC3	0	0	0	ALC_NGATE_GAIN [2:0]			0	ALC_MODE	ALC_DCY [3:0]		ALC_ATK [3:0]			1C32h				
R20 (14h)	Noise Gate	ALC_NGATE_DCY [3:0]			ALC_NGATE_ATK [3:0]			ALC_NGATE_THR [4:0]			ALC_NGATE_MODE [1:0]		ALC_NGATE_ENA	3200h					
R21 (15h)	Left ADC volume	0	0	0	0	0	0	0	ADC_VU	ADCL_VOL [7:0]							00C0h		
R22 (16h)	Right ADC volume	0	0	0	0	0	0	0	ADC_VU	ADCR_VOL [7:0]							00C0h		
R23 (17h)	Additional control(1)	0	0	0	0	0	0	0	THERR_ACT	0	0	ADC_HP	0	0	0	0	0	TOCLK_ENA	0100h

REG	NAME	15	14	13	12	11	10	9	8	7	6	5	4	3	2	1	0	DEFAULT
R24 (18h)	Additional control(2)	0	0	0	0	0	0	0	0	0	0	0	0	AIF_TR1	0	0	0	0000h
R25 (19h)	Pwr Mgmt (1)	0	0	0	0	0	DMIC_ENA	OPCLK_ENA	VMID_SEL [1:0]		BIAS_ENA	INL_ENA	INR_ENA	ADCL_ENA	ADCR_ENA	MICBIAS_ENA	0	0000h
R26 (1Ah)	Pwr Mgmt (2)	0	0	0	0	0	0	0	DACL_ENA	DACR_ENA	HPOUTL_PGA_ENA	HPOUTR_PGA_ENA	SPKOUTL_PG_A_ENA	SPKOUTR_PG_A_ENA	0	HPOUTL_PGA_MUTE	HPOUTR_PGA_MUTE	0000h
R27 (1Bh)	Additional Control (3)	0	0	0	0	0	0	0	0	0	0	0	SAMPLE_RATE_INT_MODE	0	SAMPLE_RATE [2:0]		0010h	
R28 (1Ch)	Anti-pop	0	0	0	0	0	0	0	0	0	0	0	STARTUP_BIAS_ENA	VMID_BUF_ENA	VMID_RAMP	0	0	0000h
R29 (1Dh)	Pwr Mgmt (3)	0	0	0	0	0	0	0	0	0	0	0	0	0	0	MICBIAS_EVR [1:0]		0000h
R30 (1Eh)	Clocking 3	DBCLK_DIV [2:0]			OPCLK_DIV [2:0]			TOCLK_DIV [2:0]			F256KCLK_DIV [5:0] (K)					0	005Eh	
R31 (1Fh)	Input mixer control (1)	0	0	0	0	0	0	0	0	0	0	0	0	MIXINL_MUTE	MIXINR_MUTE	MIXINL_ENA	MIXINR_ENA	0000h
R32 (20h)	Left input mixer volume	0	0	0	0	0	0	0	IN2L_MIXINL_VOL [2:0]		INPGAL_MIXINL_VOL [2:0]		IN3L_MIXINL_VOL [2:0]				0145h	
R33 (21h)	Right input mixer volume	0	0	0	0	0	0	0	IN2R_MIXINR_VOL [2:0]		INPGAR_MIXINR_VOL [2:0]		IN3R_MIXINR_VOL [2:0]				0145h	
R34 (22h)	Input mixer control (2)	0	0	0	0	0	0	0	0	0	0	IN2L_T_O_MIXINL	IN3L_T_O_MIXINL	INPGA_L_TO_MIXINL	IN2R_T_O_MIXINR	IN3R_T_O_MIXINR	INPGA_R_TO_MIXINR	0009h
R35 (23h)	Input bias control	0	0	0	0	0	0	0	0	0	0	MIXIN_BIAS [2:0]			INPGA_BIAS [2:0]			0004h
R37 (25h)	Left input PGA control	0	0	0	0	0	0	0	0	0	0	INPGA_L_ENA	IN1L_T_O_INPGAL	IN2L_T_O_INPGAL	IN3L_T_O_INPGAL	IN4L_T_O_INPGAL	0008h	
R38 (26h)	Right input PGA control	0	0	0	0	0	0	0	0	0	0	INPGA_R_ENA	IN1R_T_O_INPGAR	IN2R_T_O_INPGAR	IN3R_T_O_INPGAR	IN4R_T_O_INPGAR	0008h	
R40 (28h)	SPKOUTL volume	0	0	0	0	0	0	0	SPKOUTL_VU	SPKOUTL_ZC	SPKOUTL_VOL [6:0]						0000h	
R41 (29h)	SPKOUTR volume	0	0	0	0	0	0	0	SPKOUTR_VU	SPKOUTR_ZC	SPKOUTR_VOL [6:0]						0000h	
R47 (2Fh)	Thermal Shutdown Status	0	0	0	0	0	0	0	0	0	0	0	TEMP_ERR_HP	TEMP_WARN_HP	TEMP_ERR_SPK	TEMP_WARN_SPK	0000h	
R48 (30h)	Additional Control (4)	1	MICDET_THR [2:0]			MICSHORT_THR [1:0]		MICDET_ENA	0	MICDET_STS	MICSHORT_STS	1	0	0	TEMP_ENA_HP	TEMP_ENA_SPK	MICBIAS_LVL	8027h
R49 (31h)	Class D Control 1	0	0	0	0	0	0	0	0	SPKOUTR_ENA	SPKOUTL_ENA	0	DAC_MUTE	0	SPKOUTL_VU	SPKOUTL_PG_A_MUTE	SPKOUTR_PG_A_MUTE	0010h
R51 (33h)	Class D Control 2	0	0	0	0	0	0	0	0	0	SPK_MONO	0	0	0	CLASSD_VOL [2:0]			0003h
R56 (38h)	Clocking 4	0	0	0	0	0	1	0	1	0	0	0	MCLK_RATE [3:0]				0	0506h
R57 (39h)	DAC DSP Mixing (1)	0	0	0	0	0	0	DAC_MONOMIX	0	ADCR_DAC_SVOL [3:0]			ADC_TO_DACR [1:0]		0	0	0000h	
R58 (3Ah)	DAC DSP Mixing (2)	0	0	0	0	0	0	0	0	ADCL_DAC_SVOL [3:0]			ADC_TO_DACL [1:0]		0	0	0000h	

REG	NAME	15	14	13	12	11	10	9	8	7	6	5	4	3	2	1	0	DEFAULT	
R60 (3Ch)	DC Servo 0	0	0	0	0	0	0	0	0	INL_D CS_EN A	INL_D CS_ST ARTUP	0	0	INR_D CS_EN A	INR_D CS_ST ARTUP	0	0	0000h	
R61 (3Dh)	DC Servo 1	0	0	0	0	0	0	0	0	HP1L_ DCS_E NA	HP1L_ DCS_S TARTU P	0	HP1L_ DCS_S YNC	HP1R_ DCS_E NA	HP1R_ DCS_S TARTU P	0	0	HP1R_ DCS_S YNC	0000h
R64 (40h)	DC Servo 4	0	0	HP1_DCS_SYNC_STEPS [6:0]							0	0	1	0	0	0	0	0	0810h
R66 (42h)	DC Servo 6	0	0	0	0	0	DCS_S TARTU P_DON E_INL	DCS_S TARTU P_DON E_INR	DCS_S TARTU P_DON E_HP1 L	DCS_S TARTU P_DON E_HP1 R	0	0	0	0	0	0	0	0	0000h
R68 (44h)	Analogue PGA Bias	0	0	0	0	0	0	0	0	0	0	0	1	1	HP_PGAS_BIAS [2:0]		0	001Bh	
R69 (45h)	Analogue HP 0	0	0	0	0	0	0	0	0	HP1L_ RMV_S HORT	HP1L_ ENA_O UTP	HP1L_ ENA_D LY	HP1L_ ENA	HP1R_ RMV_S HORT	HP1R_ ENA_O UTP	HP1R_ ENA_D LY	HP1R_ ENA	0000h	
R71 (47h)	Analogue HP 2	0	0	0	0	0	0	0	HP1L_VOL [2:0]		HP1R_VOL [2:0]		HP_BIAS_BOOST [2:0]		0	0	0	01FBh	
R72 (48h)	Charge Pump 1	0	0	0	0	0	0	0	0	0	0	0	0	0	0	0	0	CP_EN A	0000h
R82 (52h)	Charge Pump B	0	0	0	0	0	0	0	0	0	0	0	0	0	1	0	0	CP_DY N_PW R	0004h
R87 (57h)	Write Sequencer Control 1	0	0	0	0	0	0	0	0	WSEQ _AUTO SEQ_E NA	0	WSEQ _ENA	0	0	0	0	0	0	0000h
R90 (5Ah)	Write Sequencer Control 2	0	0	0	0	0	0	0	WSEQ _ABOR T	WSEQ _STAR T	WSEQ_START_INDEX [6:0]						0	0000h	
R93 (5Dh)	Write Sequencer Control 3	0	0	0	0	0	0	WSEQ_CURRENT_INDEX [6:0]						0	0	0	0	WSEQ _BUSY	0000h
R94 (5Eh)	Control Interface	0	0	0	0	0	0	0	0	0	SPI_C ONTR D	SPI_4 WIRE	SPI_CF G	0	0	0	0	0	0000h
R99 (63h)	Mixer Enables	0	0	0	0	0	0	0	0	0	0	0	0	HPMIX L_ENA	HPMIX R_ENA	SPKMI XL_EN A	SPKMI XR_EN A	0000h	
R100 (64h)	Headphone Mixer (1)	0	0	0	0	0	0	0	0	HPMIX L_TO_ HPOUT L_PGA	0	DACL_ TO_HP MIXL	DACR_ TO_HP MIXL	MIXINL _TO_H PMIXL	MIXINR _TO_H PMIXL	IN4L_T O_HP MIXL	IN4R_T O_HP MIXL	0000h	
R101 (65h)	Headphone Mixer (2)	0	0	0	0	0	0	0	0	HPMIX R_TO_ HPOUT R_PGA	0	DACL_ TO_HP MIXR	DACR_ TO_HP MIXR	MIXINL _TO_H PMIXR	MIXINR _TO_H PMIXR	IN4L_T O_HP MIXR	IN4R_T O_HP MIXR	0000h	
R102 (66h)	Headphone Mixer (3)	0	0	0	0	0	0	0	HPMIX L_MUT E	MIXINL _HPMI XL_VO L	MIXINR _HPMI XL_VO L	IN4L_HPMIXL_VOL [2:0]		IN4R_HPMIXL_VOL [2:0]		0	0	013Fh	
R103 (67h)	Headphone Mixer (4)	0	0	0	0	0	0	0	HPMIX R_MUT E	MIXINL _HPMI XR_VO L	MIXINR _HPMI XR_VO L	IN4L_HPMIXR_VOL [2:0]		IN4R_HPMIXR_VOL [2:0]		0	0	013Fh	

REG	NAME	15	14	13	12	11	10	9	8	7	6	5	4	3	2	1	0	DEFAULT
R105 (69h)	Speaker Mixer (1)	0	0	0	0	0	0	0	0	SPKMI_XL_TO_SPKO_UTL_PGA	0	DAACL_TO_SPKMIXL	DACR_TO_SPKMIXL	MIXINL_TO_SPKMIXL	MIXINR_TO_SPKMIXL	IN4L_TO_SPKMIXL	IN4R_TO_SPKMIXL	0000h
R106 (6Ah)	Speaker Mixer (2)	0	0	0	0	0	0	0	0	SPKMI_XR_TO_SPKOUTR_PGA	0	DAACL_TO_SPKMIXR	DACR_TO_SPKMIXR	MIXINL_TO_SPKMIXR	MIXINR_TO_SPKMIXR	IN4L_TO_SPKMIXR	IN4R_TO_SPKMIXR	0000h
R107 (6Bh)	Speaker Mixer (3)	0	0	0	0	0	0	0	0	SPKMI_XL_MUTE	MIXINL_SPKMIXL_VOL	MIXINR_SPKMIXL_VOL	IN4L_SPKMIXL_VOL [2:0]		IN4R_SPKMIXL_VOL [2:0]		013Fh	
R108 (6Ch)	Speaker Mixer (4)	0	0	0	0	0	0	0	0	SPKMI_XR_MUTE	MIXINL_SPKMIXR_VOL	MIXINR_SPKMIXR_VOL	IN4L_SPKMIXR_VOL [2:0]		IN4R_SPKMIXR_VOL [2:0]		013Fh	
R109 (6Dh)	Speaker Mixer (5)	0	0	0	0	0	0	0	0	DAACL_SPKMIXL_VOL	DACR_SPKMIXL_VOL	DAACL_SPKMIXR_VOL	DACR_SPKMIXR_VOL	0	0	1	1	0003h
R110 (6Eh)	Beep Generator (1)	0	0	0	0	0	0	0	0	BEEP_GAIN [3:0]			0	BEEP_RATE [1:0]		BEEP_ENA	0002h	
R115 (73h)	Oscillator Trim (3)	0	0	0	0	0	0	0	0	0	0	0	OSC_TRIM_XTI [4:0] (K)				0000h	
R116 (74h)	Oscillator Trim (4)	0	0	0	0	0	0	0	0	0	1	OSC_TRIM_XTO [4:0] (K)				0020h		
R119 (77h)	Oscillator Trim (7)	0	0	0	0	0	0	0	0	XTO_CAP_SEL [3:0]			XTI_CAP_SEL [3:0]			0000h		
R124 (7Ch)	Analogue Clocking1	0	0	0	0	0	0	0	0	0	CLKOUT2_SEL [1:0]	CLKOUT3_SEL [1:0]	0	0	CLKOUT5_SEL	0011h		
R125 (7Dh)	Analogue Clocking2	0	0	0	0	0	0	0	0	PLL2_OUTDIV	PLL3_OUTDIV	0	PLL_SYSCLK_DIV [1:0]	CLKOUT3_DIV	CLKOUT2_DIV	CLKOUT5_DIV	004Bh	
R126 (7Eh)	Analogue Clocking3	0	0	0	0	0	0	0	0	0	0	1	CLKOUT2_OE	CLKOUT3_OE	1	CLKOUT5_OE	001Fh	
R127 (7Fh)	PLL Software Reset	SW_RESET_PLL [15:0]																0000h
R129 (81h)	PLL2	0	0	0	0	0	0	0	0	OSC_ENA	0	PLL2_ENA	PLL3_ENA	0	0	0	1	0001h
R131 (83h)	PLL 4	0	0	0	0	0	0	0	0	0	0	0	1	0	0	PLL_CLK_SRC	FLL_TPO_PLL3	0010h
R136 (88h)	PLL 9	0	0	0	0	0	0	0	0	0	PLL2_FRAC	1	PLL2_N [4:0]				0067h	
R137 (89h)	PLL 10	0	0	0	0	0	0	0	0	PLL2_K [7:0]							001Ch	
R138 (8Ah)	PLL 11	0	0	0	0	0	0	0	0	PLL2_K [7:0]							0071h	
R139 (8Bh)	PLL 12	0	0	0	0	0	0	0	0	PLL2_K [7:0]							00C7h	
R140 (8Ch)	PLL 13	0	0	0	0	0	0	0	0	0	PLL3_FRAC	1	PLL3_N [4:0]				0067h	
R141 (8Dh)	PLL 14	0	0	0	0	0	0	0	0	PLL3_K [7:0]							0048h	
R142 (8Eh)	PLL 15	0	0	0	0	0	0	0	0	PLL3_K [7:0]							0022h	

REG	NAME	15	14	13	12	11	10	9	8	7	6	5	4	3	2	1	0	DEFAULT	
R143 (8Fh)	PLL 16	0	0	0	0	0	0	0	0	PLL3_K [7:0]							0097h		
R150 (96h)	PLL DLL	0	0	0	0	0	0	0	0	0	0	0	0	0	0	SEQ_ENA	1	0003h	
R152 (98h)	Analogue Control 4	0	0	0	0	0	0	0	0	1	1	0	OSC_MCLK_SRC	0	0	0	0	00C0h	
R155 (9Bh)	FLL Control (1)	0	0	0	0	0	0	0	0	0	FLL_REFCLK_SRC [1:0]		0	1	FLL_F RAC	FLL_O SC_ENA	FLL_E NA	000Ch	
R156 (9Ch)	FLL Control (2)	0	0	0	0	0	0	0	FLL_OUTDIV [5:0]					0	FLL_REFCLK_DIV [1:0]		0039h		
R157 (9Dh)	FLL Control (3)	0	0	0	0	0	0	0	1	1	0	0	0	0	FLL_FRATIO [2:0]			0180h	
R159 (9Fh)	FLL Control (5)	0	0	0	0	0	0	0	0	FLL_FRC_NCO_VAL [5:0]						FLL_F RC_NCO	0032h		
R160 (A0h)	FLL Control (6)	FLL_THETA [15:0]															0018h		
R161 (A1h)	FLL Control (7)	FLL_LAMBDA [15:0]															007Dh		
R162 (A2h)	FLL Control (8)	0	0	0	0	0	0	FLL_N [9:0]									0008h		
R252 (FCh)	General test 1	0	0	0	0	0	0	0	0	0	0	0	0	0	1	0	AUTO_INC	0005h	
R256 (100h)	DF1	0	0	0	0	0	0	0	0	0	0	0	0	0	DF1_S HARED_COEF F	DF1_S HARED_COEF F_SEL	DF1_E NA	0000h	
R257 (101h)	DF2	DF1_COEFF_L0 [15:0]															0000h		
R258 (102h)	DF3	DF1_COEFF_L1 [15:0]															0000h		
R259 (103h)	DF4	DF1_COEFF_L2 [15:0]															0000h		
R260 (104h)	DF5	DF1_COEFF_R0 [15:0]															0000h		
R261 (105h)	DF6	DF1_COEFF_R1 [15:0]															0000h		
R262 (106h)	DF7	DF1_COEFF_R2 [15:0]															0000h		
R264 (108h)	LHPF1	0	0	0	0	0	0	0	0	0	0	0	0	0	LHPF_MODE	LHPF_ENA	0000h		
R265 (109h)	LHPF2	LHPF_COEFF [15:0]															0000h		
R268 (10Ch)	THREED1	0	0	0	0	0	0	0	0	0	ADC_M ONOMI X	THREE D_SIG N_L	THREE D_SIG N_R	0	THREE D_LHP F_MODE	THREE D_LHP F_ENA	THREE D_ENA	0000h	
R269 (10Dh)	THREED2	THREED_FGAINL [4:0]				THREED_CGAINL [4:0]				THREED_DELAYL [3:0]			0	0				0000h	
R270 (10Eh)	THREED3	THREED_LHPF_COEFF [15:0]															0000h		
R271 (10Fh)	THREED4	THREED_FGAINR [4:0]				THREED_CGAINR [4:0]				THREED_DELAYR [3:0]			0	0				0000h	
R276 (114h)	DRC 1	0	DRC_SIG_DET_RMS [4:0]				DRC_SIG_DET_PK [1:0]		DRC_N G_ENA	DRC_S IG_DE T_MOD E	DRC_S IG_DE T	DRC_K NEE2_OP_ENA	DRC_Q R	DRC_A NTICLI P	DRC_MODE	DRC_ENA			000Ch

REG	NAME	15	14	13	12	11	10	9	8	7	6	5	4	3	2	1	0	DEFAULT
R277 (115h)	DRC 2	0	0	0	DRC_ATK [3:0]			DRC_DCY [3:0]			DRC_MINGAIN [2:0]		DRC_MAXGAIN [1:0]				0925h	
R278 (116h)	DRC 3	DRC_NG_MINGAIN [3:0]			DRC_QR_THR [1:0]		DRC_QR_DCY [1:0]		DRC_NG_EXP [1:0]		DRC_HI_COMP [2:0]		DRC_LO_COMP [2:0]				0000h	
R279 (117h)	DRC 4	0	0	0	0	0	DRC_KNEE_IP [5:0]				DRC_KNEE_OP [4:0]				0000h			
R280 (118h)	DRC 5	0	0	0	0	0	DRC_KNEE2_IP [4:0]				DRC_KNEE2_OP [4:0]				0000h			
R285 (11Dh)	Tloopback	0	0	0	0	0	0	0	0	0	0	0	0	0	0	TLB_ENA	TLB_MODE	0000h
R335 (14Fh)	EQ1	0	0	0	0	0	0	0	0	0	0	0	0	0	EQ_SHARED_COEFF	EQ_SHARED_COEFF_SEL	EQ_ENA	0004h
R336 (150h)	EQ2	EQL_B1_GAIN [4:0]				EQL_B2_GAIN [4:0]				EQL_B3_GAIN [4:0]				0		6318h		
R337 (151h)	EQ3	EQL_B4_GAIN [4:0]				EQL_B5_GAIN [4:0]				0	0	0	0	0	0	0	0	6300h
R338 (152h)	EQ4	EQL_B1_A [15:0]																0FCAh
R339 (153h)	EQ5	EQL_B1_B [15:0]																0400h
R340 (154h)	EQ6	EQL_B1_PG [15:0]																00D8h
R341 (155h)	EQ7	EQL_B2_A [15:0]																1EB5h
R342 (156h)	EQ8	EQL_B2_B [15:0]																F145h
R343 (157h)	EQ9	EQL_B2_C [15:0]																0B75h
R344 (158h)	EQ10	EQL_B2_PG [15:0]																01C5h
R345 (159h)	EQ11	EQL_B3_A [15:0]																1C58h
R346 (15Ah)	EQ12	EQL_B3_B [15:0]																F373h
R347 (15Bh)	EQ13	EQL_B3_C [15:0]																0A54h
R348 (15Ch)	EQ14	EQL_B3_PG [15:0]																0558h
R349 (15Dh)	EQ15	EQL_B4_A [15:0]																168Eh
R350 (15Eh)	EQ16	EQL_B4_B [15:0]																F829h
R351 (15Fh)	EQ17	EQL_B4_C [15:0]																07ADh
R352 (160h)	EQ18	EQL_B4_PG [15:0]																1103h
R353 (161h)	EQ19	EQL_B5_A [15:0]																0564h
R354 (162h)	EQ20	EQL_B5_B [15:0]																0559h
R355 (163h)	EQ21	EQL_B5_PG [15:0]																4000h
R356 (164h)	EQ22	EQR_B1_GAIN [4:0]				EQR_B2_GAIN [4:0]				EQR_B3_GAIN [4:0]				0		6318h		

REG	NAME	15	14	13	12	11	10	9	8	7	6	5	4	3	2	1	0	DEFAULT
R357 (165h)	EQ23	EQR_B4_GAIN [4:0]					EQR_B5_GAIN [4:0]					0	0	0	0	0	0	6300h
R358 (166h)	EQ24	EQR_B1_A [15:0]																0FCAh
R359 (167h)	EQ25	EQR_B1_B [15:0]																0400h
R360 (168h)	EQ26	EQR_B1_PG [15:0]																00D8h
R361 (169h)	EQ27	EQR_B2_A [15:0]																1EB5h
R362 (16Ah)	EQ28	EQR_B2_B [15:0]																F145h
R363 (16Bh)	EQ29	EQR_B2_C [15:0]																0B75h
R364 (16Ch)	EQ30	EQR_B2_PG [15:0]																01C5h
R365 (16Dh)	EQ31	EQR_B3_A [15:0]																1C58h
R366 (16Eh)	EQ32	EQR_B3_B [15:0]																F373h
R367 (16Fh)	EQ33	EQR_B3_C [15:0]																0A54h
R368 (170h)	EQ34	EQR_B3_PG [15:0]																0558h
R369 (171h)	EQ35	EQR_B4_A [15:0]																168Eh
R370 (172h)	EQ36	EQR_B4_B [15:0]																F829h
R371 (173h)	EQ37	EQR_B4_C [15:0]																07ADh
R372 (174h)	EQ38	EQR_B4_PG [15:0]																1103h
R373 (175h)	EQ39	EQR_B5_A [15:0]																0564h
R374 (176h)	EQ40	EQR_B5_B [15:0]																0559h
R375 (177h)	EQ41	EQR_B5_PG [15:0]																4000h
R513 (201h)	GPIO 2	0	0	0	0	0	GP2_P OL	0	0	0	GP2_L VL	0	GP2_FN [4:0]				0000h	
R514 (202h)	GPIO 3	0	0	0	0	0	GP3_P OL	0	0	0	GP3_L VL	0	GP3_FN [4:0]				0000h	
R516 (204h)	GPIO 5	GP5_D IR	GP5_P U	GP5_P D	0	0	GP5_P OL	GP5_O P_CFG	GP5_D B	0	GP5_L VL	0	GP5_FN [4:0]				8100h	
R517 (205h)	GPIO 6	GP6_D IR	GP6_P U	GP6_P D	0	0	GP6_P OL	GP6_O P_CFG	GP6_D B	0	GP6_L VL	0	GP6_FN [4:0]				8100h	
R560 (230h)	Interrupt Status 1	0	0	0	0	0	0	0	0	0	0	GP6_EI NT	GP5_EI NT	0	0	0	0	0000h
R561 (231h)	Interrupt Status 2	MICSC D_EIN T	MICD_ EINT	FIFOS_ ERR_E INT	ALC_L OCK_E INT	ALC_T HRESH _EINT	ALC_S AT_EIN T	ALC_P KOV R_EINT	ALC_N GATE_ EINT	WSEQ_ DONE_ EINT	DRC_A CTDET _EINT	FLL_L OCK_E INT	0	PLL3_L OCK_E INT	PLL2_L OCK_E INT	0	TEMP_ SHUT_ EINT	0000h
R568 (238h)	Interrupt Status 1 Mask	0	0	0	0	0	0	0	0	0	0	IM_GP 6_EINT	IM_GP 5_EINT	0	0	0	0	0030h
R569 (239h)	Interrupt Status 2 Mask	IM_MIC SCD_E INT	IM_MIC D_EIN T	IM_FIF OS_ER R_EIN T	IM_AL C_LOC K_EIN T	IM_AL C_THR ESH_E INT	IM_AL C_SAT _EINT	IM_AL C_PKO VR_EI NT	IM_AL C_NGA TE_EI NT	IM_WS EQ_DO NE_EI NT	IM_DR C_ACT DET_EI NT	IM_FLL _LOCK _EINT	1	IM_PLL 3_LOC K_EIN T	IM_PLL 2_LOC K_EIN T	1	IM_TE MP_SH UT_EI NT	FFFFh

REG	NAME	15	14	13	12	11	10	9	8	7	6	5	4	3	2	1	0	DEFAULT	
R576 (240h)	Interrupt Control	0	0	0	0	0	0	0	0	0	0	0	0	0	0	0	0	IRQ_P OL	0000h
R584 (248h)	IRQ Debounce	0	0	0	0	0	0	0	0	0	0	FLL_L OCK_D B	1	PLL3_L OCK_D B	PLL2_L OCK_D B	1	TEMP_ SHUT_ DB	003Fh	
R586 (24Ah)	MICINT Source Pol	MICSC D_IRQ _POL	MICD_I RQ_PO L	0	0	0	0	0	0	0	0	0	0	0	0	0	0	0000h	
R768 (300h)	DSP2 Power Management	0	0	0	1	1	1	0	0	0	0	0	0	0	0	0	0	DSP2_ ENA	1C00h
R1037 (40Dh)	DSP2_ExecCon trol	0	0	0	0	0	0	0	0	0	0	DSP2_ STOPC	DSP2_ STOPS	DSP2_ STOPI	DSP2_ STOP	DSP2_ RUNR	DSP2_ RUN	0000h	
R4096 (1000h)	Write Sequencer 0	0	0	WSEQ_ADDR0 [13:0]													001Ch		
R4097 (1001h)	Write Sequencer 1	0	0	0	0	0	0	0	0	WSEQ_DATA0 [7:0]								0003h	
R4098 (1002h)	Write Sequencer 2	0	0	0	0	0	WSEQ_DATA_WIDTH0 [2:0]			0	0	0	0	WSEQ_DATA_START0 [3:0]			0103h		
R4099 (1003h)	Write Sequencer 3	0	0	0	0	0	0	0	WSEQ _EOS0	0	0	0	0	WSEQ_DELAY0 [3:0]			0000h		
R4100 (1004h)	Write Sequencer 4	0	0	WSEQ_ADDR1 [13:0]													0019h		
R4101 (1005h)	Write Sequencer 5	0	0	0	0	0	0	0	0	WSEQ_DATA1 [7:0]								0007h	
R4102 (1006h)	Write Sequencer 6	0	0	0	0	0	WSEQ_DATA_WIDTH1 [2:0]			0	0	0	0	WSEQ_DATA_START1 [3:0]			0206h		
R4103 (1007h)	Write Sequencer 7	0	0	0	0	0	0	0	WSEQ _EOS1	0	0	0	0	WSEQ_DELAY1 [3:0]			0000h		
R4104 (1008h)	Write Sequencer 8																		
R4603 (11FBh)	Write Sequencer 507	Register Addresses R4104 (1008h) to contain R4603 (11FBh) Write Sequencer Control Registers																	
R4604 (11FCh)	Write Sequencer 508	0	0	WSEQ_ADDR127 [13:0]													0000h		
R4605 (11FDh)	Write Sequencer 509	0	0	0	0	0	0	0	0	WSEQ_DATA127 [7:0]								0000h	
R4606 (11FEh)	Write Sequencer 510	0	0	0	0	0	WSEQ_DATA_WIDTH12 7 [2:0]			0	0	0	0	WSEQ_DATA_START127 [3:0]			0000h		
R4607 (11FFh)	Write Sequencer 511	0	0	0	0	0	0	0	WSEQ _EOS1 27	0	0	0	0	WSEQ_DELAY127 [3:0]			0000h		
R16384 (4000h)	RETUNEADC_ SHARED_COE FF_1	0	0	0	0	0	0	0	0	ADC_R ETUNE _SCV	RETUNEADC_SHARED_COEFF_22_16 [6:0]						0000h		
R16385 (4001h)	RETUNEADC_ SHARED_COE FF_0	RETUNEADC_SHARED_COEFF_15_00 [15:0]															0000h		
R16386 (4002h)	RETUNEDAC_ SHARED_COE FF_1	0	0	0	0	0	0	0	0	ADC_R ETUNE _SCV	RETUNEDAC_SHARED_COEFF_23_16 [6:0]						0000h		
R16387 (4003h)	RETUNEDAC_ SHARED_COE FF_0	RETUNEDAC_SHARED_COEFF_15_00 [15:0]															0000h		
R16388 (4004h)	SOUNDSTAGE _ENABLES_1	0	0	0	0	0	0	0	0	SOUNDSTAGE_ENABLES_23_16 [7:0]								0000h	
R16389 (4005h)	SOUNDSTAGE _ENABLES_0	SOUNDSTAGE_ENABLES_15_06 [9:0]										RTN_A DC_EN A	RTN_D AC_EN A	HDBAS S_ENA	HPF2_ ENA	HPF1_ ENA	VSS_E NA	0000h	

REG	NAME	15	14	13	12	11	10	9	8	7	6	5	4	3	2	1	0	DEFAULT
R16896 (4200h)	HDBASS_AI_1																	0002h
R16925 (421Dh)	HDBASS_PG_0	Register Addresses R16896 (4200h) to R16925 (421Dh) contain HD Bass Control Registers																999Ah
R17408 (4400h)	HPF_C_1																	0083h
R17409 (4401h)	HPF_C_0	Register Addresses R17408 (4400h) to R17409 (4401h) contain DAC High Pass Filter Control Registers																98ADh
R17920 (4600h)	ADCL_RETUNE _C1_1																	007Fh
R19007 (4A3Fh)	ADCR_RETUN E_C32_0	Register Addresses R17920 (4600h) to R19007 (4A3Fh) contain ADC ReTune Control Registers																0000h
R19456 (4C00h)	DACL_RETUNE _C1_1																	007Fh
R20543 (503Fh)	DACR_RETUN E_C32_0	Register Addresses R19456 (4C00h) to R20543 (503Fh) contain DAC ReTune Control Registers																0000h
R20992 (5200h)	VSS_XHD2_1																	008Ch
R21139 (5293h)	VSS_XTS32_0	Register Addresses R20992 (5200h) to R21139 (5293h) contain VSS Control Registers																8580h

REGISTER BITS BY ADDRESS

REGISTER ADDRESS	BIT	LABEL	DEFAULT	DESCRIPTION
R0 (00h) Left Input volume	8	IN_VU	0	Input PGA Volume and Mute Update Writing a 1 to this bit will cause the INL and INR volume and mute settings to be updated simultaneously
	7	INPGAL_MUTE	1	Left input PGA Mute 0 = Unmuted 1 = Muted
	6	INL_ZC	0	INL PGA Zero Cross Detector 0 = Change gain immediately 1 = Change gain on zero cross only
	5:0	INL_VOL [5:0]	01_1111	Left input PGA Volume -23.25dB to +24.00dB in 0.75dB steps.

Register 00h Left Input volume

REGISTER ADDRESS	BIT	LABEL	DEFAULT	DESCRIPTION
R1 (01h) Right Input volume	15:12	CUST_ID [3:0]	0000	Reading from this register will indicate the Customer ID.
	11:9	CHIP_REV [2:0]	011	Reading from this register will indicate the Chip Revision ID. 000 = Rev A 001 = Rev B 010 = Rev C 011 = Rev D
	8	IN_VU	0	Input PGA Volume and Mute Update Writing a 1 to this bit will cause the INL and INR volume and mute settings to be updated simultaneously
	7	INPGAR_MUTE	1	Right input PGA Mute 0 = Unmuted 1 = Muted
	6	INR_ZC	0	INR PGA Zero Cross Detector 0 = Change gain immediately 1 = Change gain on zero cross only
	5:0	INR_VOL [5:0]	01_1111	Right input PGA Volume -23.25dB to +24.00dB in 0.75dB steps.

Register 01h Right Input volume

REGISTER ADDRESS	BIT	LABEL	DEFAULT	DESCRIPTION
R2 (02h) HPOUTL volume	8	HPOUT_VU	0	Headphone Output PGA Volume and Mute Update. Writing 1 to this bit will cause the HPOUTL and HPOUTR volume and mute settings to be updated simultaneously.
	7	HPOUTL_ZC	0	HPOUTL_VOL (Left Headphone Output PGA) Zero Cross Enable 0 = Zero cross disabled 1 = Zero cross enabled
	6:0	HPOUTL_VOL [6:0]	000_0000	Left Headphone Output PGA Volume 000_0000 to 010_1111 = Mute 011_0000 to 011_0101 = -68dB 011_0110 = -67dB ...in 1dB steps 111_1001 = 0dB ... 111_1111 = +6dB

Register 02h HPOUTL volume

REGISTER ADDRESS	BIT	LABEL	DEFAULT	DESCRIPTION
R3 (03h) HPOUTR volume	8	HPOUT_VU	0	Headphone Output PGA Volume and Mute Update. Writing 1 to this bit will cause the HPOUTL and HPOUTR volume and mute settings to be updated simultaneously.
	7	HPOUTR_ZC	0	HPOUTR_VOL (Right Headphone Output PGA) Zero Cross Enable 0 = Zero cross disabled 1 = Zero cross enabled
	6:0	HPOUTR_VOL [6:0]	000_0000	Right Headphone Output PGA Volume 000_0000 to 010_1111 = Mute 011_0000 to 011_0101 = -68dB 011_0110 = -67dB ...in 1dB steps 111_1001 = 0dB ... 111_1111 = +6dB

Register 03h HPOUTR volume

REGISTER ADDRESS	BIT	LABEL	DEFAULT	DESCRIPTION
R4 (04h) Clocking1	10:9	DSPCLK_DIV [1:0]	00	DSP Clock Divider 00 = MCLK 01 = MCLK / 2 10 = MCLK / 4 11 = Reserved This field is for read-back only; it is set automatically and cannot be adjusted. <i>Protected by security key.</i>
	8:6	ADCSYS_CLK_DIV [2:0]	000	ADC Sample Rate Divider 000 = SYSCLK 001 = Reserved 010 = SYSCLK / 2 011 = SYSCLK / 3 100 = SYSCLK / 4 101 = Reserved 110 = SYSCLK / 6 111 = Reserved This field is for read-back only; it is set automatically and cannot be adjusted. <i>Protected by security key.</i>
	5:3	DACSYS_CLK_DIV [2:0]	100	DAC Sample Rate Divider 000 = SYSCLK 001 = Reserved 010 = SYSCLK / 2 011 = SYSCLK / 3 100 = SYSCLK / 4 101 = Reserved 110 = SYSCLK / 6 111 = Reserved This field is for read-back only; it is set automatically and cannot be adjusted. <i>Protected by security key.</i>
	2:1	SYSClk_DIV [1:0]	00	SYSClk Divider 00 = MCLK 01 = MCLK / 2 10 = MCLK / 4

REGISTER ADDRESS	BIT	LABEL	DEFAULT	DESCRIPTION
				11 = Reserved This field is for read-back only; it is set automatically and cannot be adjusted. Note that the division is applied to the selected MCLK source, including FLL / PLL when applicable. <i>Protected by security key.</i>

Register 04h Clocking1

REGISTER ADDRESS	BIT	LABEL	DEFAULT	DESCRIPTION
R5 (05h) ADC & DAC Control 1	6	ADCR_DAT_INV	0	Right ADC Invert 0 = Right ADC output not inverted 1 = Right ADC output inverted
	5	ADCL_DAT_INV	0	Left ADC Invert 0 = Left ADC output not inverted 1 = Left ADC output inverted
	4	DAC_MUTE_RAMP	1	DAC Soft Mute Control 0 = Muting the DAC (DAC_MUTE = 1) will cause the volume to change immediately to mute. 1 = Muting the DAC (DAC_MUTE = 1) will cause the volume to ramp down gradually to mute.
	3	DAC_MUTE	1	Digital DAC Mute 0 = Un-mute 1 = Mute Note that this bit also exists in R49. Reading or writing to either location has the same effect.
	2:1	DAC_DEEMP [1:0]	00	De-Emphasis Control 00 = No de-emphasis 01 = De-emphasis for 32kHz sample rate 10 = De-emphasis for 44.1kHz sample rate 11 = De-emphasis for 48kHz sample rate
	0	ADC_HPF_DIS	0	ADC High-Pass Filter Disable 0 = Enable 1 = Disable

Register 05h ADC & DAC Control 1

REGISTER ADDRESS	BIT	LABEL	DEFAULT	DESCRIPTION
R6 (06h) ADC & DAC Control 2	13:12	ADC_HPF_SR [1:0]	10	ADC High-Pass Filter Sample rate 00 = 8k, 11.025k, 12k 01 = 16k, 22.025k, 24k 10 = 32k, 44.1, 48k 11 = 88.2k, 96k This field is for read-back only; it is set automatically and cannot be adjusted. <i>Protected by security key.</i>
	10	ADC_HPF_MODE	0	ADC High-Pass Filter Mode select 0 = Hi-Fi mode (1st order) 1 = Application mode (2nd order)
	9:7	ADC_HPF_CUT [2:0]	000	ADC High-Pass Filter Cutoff Note that the cut-off frequency scales with sample rate.
	6	DACR_DAT_INV	0	Right DAC Invert

REGISTER ADDRESS	BIT	LABEL	DEFAULT	DESCRIPTION
		V		0 = Right DAC input not inverted 1 = Right DAC input inverted
	5	DACL_DAT_INV	0	Left DAC Invert 0 = Left DAC input not inverted 1 = Left DAC input inverted
	3	DAC_UNMUTE_RAMP	1	DAC Soft Unmute Control 0 = Unmuting the DAC (DAC_MUTE = 0) will cause the volume to change immediately to the DACL_VOL/DACR_VOL settings. 1 = Unmuting the DAC (DAC_MUTE = 0) will cause the volume to ramp up gradually to the DACL_VOL/DACR_VOL settings.
	2	DAC_MUTERATE	0	DAC Soft Mute Ramp Rate 0 = Fast ramp (maximum ramp time 10.7ms) 1 = Slow ramp (maximum ramp time 171ms). Note that the ramp rate scales with sample rate (fs). Quoted values are correct for fs = 48kHz.
	0	DAC_HP	0	DAC Oversampling Ratio 0 = Low Power (typically 64 x fs) 1 = High Performance (typically 128 x fs)

Register 06h ADC & DAC Control 2

REGISTER ADDRESS	BIT	LABEL	DEFAULT	DESCRIPTION
R7 (07h) Audio Interface 0	12	AIFDAC_TDM_MODE	0	DAC TDM Mode Select 0 = Normal DACDAT operation (1 stereo slot) 1 = TDM enabled on DACDAT (2 stereo slots)
	11	AIFDAC_TDM_SLOT	0	DACDAT TDM Slot Select 0 = DACDAT data input on slot 0 1 = DACDAT data input on slot 1
	10	AIFADC_TDM_MODE	0	ADC TDM Mode Select 0 = Normal ADCDAT operation (1 stereo slot) 1 = TDM enabled on ADCDAT (2 stereo slots)
	9	AIFADC_TDM_SLOT	0	ADCDAT TDM Slot Select 0 = ADCDAT data input on slot 0 1 = ADCDAT data input on slot 1
	8	ADC_LRSWAP	0	Swap left/right ADC data on the interface 0 = Normal 1 = ADCDAT channels swapped
	7	BCLK_INV	0	BCLK Invert 0 = BCLK not inverted 1 = BCLK inverted
	6	MSTR	0	Audio Interface Mode Select 0 = Slave mode 1 = Master mode
	5	DAC_LRSWAP	0	Swap left/right DAC data on the interface 0 = Normal 1 = DACDAT channels swapped
	4	LRCLK_INV	0	Right, left and I2S modes – LRCLK polarity 0 = normal LRCLK polarity 1 = invert LRCLK polarity DSP Mode – mode A/B select 0 = MSB is available on 2nd BCLK rising edge after LRCLK rising edge (mode A)

REGISTER ADDRESS	BIT	LABEL	DEFAULT	DESCRIPTION
				1 = MSB is available on 1st BCLK rising edge after LRCLK rising edge (mode B)
	3:2	WL [1:0]	10	Digital Audio Interface Word Length 00 = 16 bits 01 = 20 bits 10 = 24 bits 11 = 32 bits
	1:0	FMT [1:0]	10	Digital Audio Interface Format 00 = Right justified 01 = Left justified 10 = I2S Format 11 = DSP Mode

Register 07h Audio Interface 0

REGISTER ADDRESS	BIT	LABEL	DEFAULT	DESCRIPTION
R8 (08h) Clocking2	11	CLKREG_OVD	0	Clock Configuration Override 0 = MCLK_SRC, OSC_ENA and CLKOUT5_SEL registers are controlled by the GPIO5 pin; PLL2_ENA, PLL3_ENA, CLKOUT2_DIV, CLKOUT5_DIV and CLKOUT3_SEL registers are locked to fixed values. 1 = Clocking registers are controlled as normal via Control Interface. This bit must be set to 1 to support GPIO functionality on GPIO5.
	10:9	MCLK_SRC [1:0]	00	MCLK source select 00 = MCLK pin 01 = FLL output 10 = PLL3 or Oscillator (selected by OSC_MCLK_SRC) 11 = Reserved If CLKREG_OVD = 0, then MCLK_SRC is controlled by the GPIO5 pin. If CLKREG_OVD = 0 and GPIO5 = 1, then MCLK_SRC = 01 (FLL) and MCLK_SRC cannot be changed by the Control Interface. If CLKREG_OVD = 0 and GPIO5 = 0, then MCLK_SRC = 00 (MCLK) by default, but the value can be changed via the Control Interface. If CLKREG_OVD = 1 then MCLK_SRC= 00 (MCLK) by default, but the value can be changed via the Control Interface.
	8:6	CLASSD_CLK_DIV [2:0]	111	Class D Clock Divider 000 = SYSCLK 001 = SYSCLK / 2 010 = SYSCLK / 3 011 = SYSCLK / 4 100 = SYSCLK / 6 101 = SYSCLK / 8 110 = SYSCLK / 12 111 = SYSCLK / 16 This field is for read-back only; it is set automatically and cannot be adjusted. <i>Protected by security key.</i>
	5	SYSCLK_ENA	1	SYSCLK enable 0 = Disabled 1 = Enabled

REGISTER ADDRESS	BIT	LABEL	DEFAULT	DESCRIPTION
	3:0	BCLK_DIV [3:0]	0100	BCLK Rate 0000 = DSPCLK 0001 = Reserved 0010 = DSPCLK / 2 0011 = DSPCLK / 3 0100 = DSPCLK / 4 (default) 0101 = Reserved 0110 = DSPCLK / 6 0111 = DSPCLK / 8 1000 = Reserved 1001 = DSPCLK / 12 1010 = DSPCLK / 16 1011 = DSPCLK / 24 1100 = Reserved 1101 = DSPCLK / 32 1110 = DSPCLK / 32 1111 = DSPCLK / 32

Register 08h Clocking2

REGISTER ADDRESS	BIT	LABEL	DEFAULT	DESCRIPTION
R9 (09h) Audio Interface 1	11	AUTOMUTE_STATUS	0	Readback of the DAC automute status 0 = Automute not detected 1 = Automute detected
	9:8	DAC_AUTOMUTE_SAMPLES [1:0]	11	Selects the number of consecutive zero DAC samples that will be interpreted as an Automute. 00 = 128 samples 01 = 256 samples 10 = 512 samples 11 = 1024 samples
	7	DAC_AUTOMUTE	0	DAC Auto-Mute Control 0 = Disabled 1 = Enabled
	4	DAC_COMP	0	DAC Companding Enable 0 = disabled 1 = enabled
	3	DAC_COMPMODE	0	DAC Companding Type 0 = μ -law 1 = A-law
	2	ADC_COMP	0	ADC Companding Enable 0 = disabled 1 = enabled
	1	ADC_COMPMODE	0	ADC Companding Type 0 = μ -law 1 = A-law
	0	LOOPBACK	0	Digital Loopback Function 0 = No loopback 1 = Loopback enabled (ADC data output is directly input to DAC data input).

Register 09h Audio Interface 1

REGISTER ADDRESS	BIT	LABEL	DEFAULT	DESCRIPTION
R10 (0Ah) Left DAC volume	8	DAC_VU	0	DAC Volume Update Writing a 1 to this bit will cause left and right DAC volume to be updated simultaneously
	7:0	DACL_VOL [7:0]	1100_0000	Left DAC Digital Volume Control 00h = Digital Mute 01h = -71.625dB 02h = -71.250dB ... 0.375dB steps up to C0h = 0dB (default) FFh = 23.625dB

Register 0Ah Left DAC volume

REGISTER ADDRESS	BIT	LABEL	DEFAULT	DESCRIPTION
R11 (0Bh) Right DAC volume	8	DAC_VU	0	DAC Volume Update Writing a 1 to this bit will cause left and right DAC volume to be updated simultaneously
	7:0	DACR_VOL [7:0]	1100_0000	Right DAC Digital Volume Control 00h = Digital Mute 01h = -71.625dB 02h = -71.250dB ... 0.375dB steps up to C0h = 0dB (default) FFh = 23.625dB

Register 0Bh Right DAC volume

REGISTER ADDRESS	BIT	LABEL	DEFAULT	DESCRIPTION
R14 (0Eh) Audio Interface 2	10:0	AIF_RATE [10:0]	000_0100_0000	LRCLK Rate LRCLK clock output = BCLK / AIF_RATE Integer (LSB = 1) Valid from 4..2047 Default (040h) = 64 BCLKs per LRCLK

Register 0Eh Audio Interface 2

REGISTER ADDRESS	BIT	LABEL	DEFAULT	DESCRIPTION
R15 (0Fh) Software Reset	15:0	SW_RESET [15:0]	0000_0000_0000_0000 0	Writing to this register resets all non-PLL registers to their default state. Registers R114 (72h) through to R152 (98h) are not affected by this reset. Reading from this register will indicate Chip ID 6243h.

Register 0Fh Software Reset

REGISTER ADDRESS	BIT	LABEL	DEFAULT	DESCRIPTION
------------------	-----	-------	---------	-------------

REGISTER ADDRESS	BIT	LABEL	DEFAULT	DESCRIPTION
R17 (11h) ALC1	10	ALC_INACTIVE_ENA	0	Select whether the ALC is in Active Mode (that is, ALC is controlling the PGA gain) or in Monitor Mode (the analogue controls are disabled). Note that at least one of ALCL_ENA and ALCR_ENA must also be enabled 0 = ALC is in Active Mode 1 = ALC is in Monitor Mode
	9	ALC_LVL_MODE	0	Select the range of the ALC target level. 0 = -28.5dBFS to -6dBFS in 1.5dB steps 1 = -22.5dBFS to -1.5dBFS in 1.5dB steps
	8	ALCL_ENA	0	Select ALC on the Left channel 0 = Disabled (PGA gain set by INL_VOL) 1 = Enabled Note that in stereo mode, the left and right PGA volumes, and left and right boost mixer volumes, must be the same before setting ALCL_ENA = 1 and ALCR_ENA = 1
	7	ALCR_ENA	0	Select ALC on the Right channel 0 = Disabled (PGA gain set by INR_VOL) 1 = Enabled Note that in stereo mode, the left and right PGA volumes, and left and right boost mixer volumes, must be the same before setting ALCL_ENA = 1 and ALCR_ENA = 1
	6:4	ALC_MAXGAIN [2:0]	111	Maximum ALC gain 000 = -18dB 001 = -12dB 010 = -6dB 011 = 0dB 100 = +6dB 101 = +12dB 110 = +18dB 111 = +24dB
	3:0	ALC_LVL [3:0]	1011	Set the Target signal level at the ADC input. Note that the target level is also determined by ALC_LVL_MODE. ALC_LVL_MODE = 0 0000 = -28.5dBFS 0001 = -27.0dBFS ...in 1.5dB steps to... 1111 = -6dBFS ALC_LVL_MODE = 1 0000 = -22.5dBFS 0001 = -21.0dBFS ...in 1.5dB steps to... 1110 = -1.5dBFS 1111 = -1.5dBFS

Register 11h ALC1

REGISTER ADDRESS	BIT	LABEL	DEFAULT	DESCRIPTION
R18 (12h) ALC2	15	ALC_LOCK_STS	0	Readback of the ALC Lock Status. Set when ADC signal = ALC_LVL
	14	ALC_THRESH_STS	0	Readback of the ALC Threshold Level status (when ALC_LOCK_STS = 0) 0 = ADC signal < ALC_LVL 1 = ADC signal > ALC_LVL
	13	ALC_SAT_STS	0	Readback of the ALC saturation status. 0 = ADC signal = ALC_LVL 1 = ADC signal < ALC_LVL but maximum ALC Gain has been reached
	12	ALC_PKOVR_STS	0	Readback of the ALC Peak Limiter Overload status. Set when ADC input signal exceeds -1.16dBFS
	11	ALC_NGATE_STS	0	Readback of the ALC Noise Gate status. 0 = ADC input signal level > ALC_NGATE_THR 1 = ADC input signal level < ALC_NGATE_THR
	7	ALC_ZC	0	ALC Zero Cross Detector 0 = Change gain immediately 1 = Change gain on zero cross only
	6:4	ALC_MINGAIN [2:0]	000	Minimum ALC gain 000 = -23.25dB 001 = -17.25dB 010 = -11.25dB 011 = -5.25dB 100 = +0.75dB 101 = +6.75dB 110 = +12.75dB 111 = +18.75dB
	3:0	ALC_HLD [3:0]	0000	ALC Hold time before the gain ramp-up starts 0000 = 0.00ms 0001 = 2.67ms 0010 = 5.33ms 0011 = 10.7ms 0100 = 21.3ms 0101 = 42.7ms 0110 = 85.3ms 0111 = 171ms 1000 = 341ms 1001 = 683ms 1010 = 1.37s 1011 = 2.73s 1100 = 5.46s 1101 = 10.9s 1110 = 21.8s 1111 = 43.7s

Register 12h ALC2

REGISTER ADDRESS	BIT	LABEL	DEFAULT	DESCRIPTION
R19 (13h) ALC3	12:10	ALC_NGATE_GAIN [2:0]	111	Noise Gate Gain level. This is the PGA gain level used within the ALC Noise Gate function. 000 = -23.25dB 001 = -18dB 010 = -12dB 011 = -6dB 100 = 0dB 101 = +6dB 110 = +12dB 111 = +18dB
	8	ALC_MODE	0	ALC Mode 0 = Normal ALC Mode 1 = Limiter Mode Note that ALCL_ENA and ALCR_ENA must both be set to 0 before changing ALC_MODE, otherwise unexpected behaviour may result.
	7:4	ALC_DCY [3:0]	0011	Sets the Gain Decay Rate (measured in time per 1.5dB step). If ALC_MODE = 0 0000 = 0.41ms / step 0001 = 0.82ms / step ...doubling with each step to... 1010 = 420ms / step 1011 = 840ms / step 1100 to 1111 = Reserved If ALC_MODE = 1 0000 = 0.082ms / step 0001 = 0.164ms / step ...doubling with each step to... 1010 = 83.9ms / step 1011 = 168ms / step 1100 to 1111 = Reserved Note that when 88.2kHz or 96kHz sample rate is selected, the Gain Decay time is defined as for the ALC_MODE=0 case above.
	3:0	ALC_ATK [3:0]	0010	Sets the Gain Attack Rate (measured in time per 1.5dB step). If ALC_MODE = 0 0000 = 0.104ms / step 0001 = 0.208ms / step ...doubling with each step to... 1010 = 106ms / step 1011 to 1111 = Reserved If ALC_MODE = 1 0000 = 0.020ms / step 0001 = 0.041ms / step ...doubling with each step to... 1010 = 21.0ms / step 1011 to 1111 = Reserved Note that when 88.2kHz or 96kHz sample rate is selected, the Gain Attack time is defined as for the ALC_MODE=0 case above.

Register 13h ALC3

REGISTER ADDRESS	BIT	LABEL	DEFAULT	DESCRIPTION
R20 (14h) Noise Gate	15:12	ALC_NGATE_D CY [3:0]	0011	<p>Sets the Noise Gate Gain Decay Rate (time taken to ramp up to the ALC_NGATE_GAIN level), measured in time per 1.5dB step.</p> <p>If ALC_MODE = 0 0000 = 0.41ms / step 0001 = 0.82ms / step ...doubling with each step to... 1010 = 420ms / step 1011 = 840ms / step 1100 to 1111 = Reserved</p> <p>If ALC_MODE = 1 0000 = 0.082ms / step 0001 = 0.164ms / step ...doubling with each step to... 1010 = 83.9ms / step 1011 = 168ms / step 1100 to 1111 = Reserved</p> <p>Note that when 88.2kHz or 96kHz sample rate is selected, the Noise Gate Gain Decay time is defined as for the ALC_MODE=0 case above.</p>
	11:8	ALC_NGATE_A TK [3:0]	0010	<p>Sets the Gain Attack Rate (time taken to ramp down to the ALC_NGATE_GAIN level), measured in time per 1.5dB step.</p> <p>If ALC_MODE = 0 0000 = 0.10ms / step 0001 = 0.21ms / step ...doubling with each step to... 1010 = 106ms / step 1011 to 1111 = Reserved</p> <p>If ALC_MODE = 1 0000 = 0.020ms / step 0001 = 0.041ms / step ...doubling with each step to... 1010 = 21.0ms / step 1011 to 1111 = Reserved</p> <p>Note that when 88.2kHz or 96kHz sample rate is selected, the Noise Gain Attack time is defined as for the ALC_MODE=0 case above.</p>
	7:3	ALC_NGATE_T HR [4:0]	0_0000	<p>Noise Gate Threshold. If the input signal falls below this level, the Noise Gate function is triggered. -76.5dB to -30dB in 1.5dB steps.</p>
	2:1	ALC_NGATE_M ODE [1:0]	00	<p>Noise gate mode 00 = Hold PGA gain static when noise gate triggers 01 = Mute ADC output immediately when noise gate triggers. 10 = Ramp PGA Gain to ADC_NGATE_GAIN level when Noise Gate triggers. 11 = Reserved</p>
	0	ALC_NGATE_E NA	0	<p>Noise Gate function enable 0 = Disable 1 = Enable</p>

Register 14h Noise Gate

REGISTER ADDRESS	BIT	LABEL	DEFAULT	DESCRIPTION
R21 (15h) Left ADC volume	8	ADC_VU	0	ADC Volume Update Writing a 1 to this bit will cause left and right ADC volume to be updated simultaneously
	7:0	ADCL_VOL [7:0]	1100_0000	Left ADC Digital Volume 00h = mute 01h = -71.625dB 02h = -71.250dB ...0.375dB steps C0h = 0dB (default) ... FFh = 23.625dB

Register 15h Left ADC volume

REGISTER ADDRESS	BIT	LABEL	DEFAULT	DESCRIPTION
R22 (16h) Right ADC volume	8	ADC_VU	0	ADC Volume Update Writing a 1 to this bit will cause left and right ADC volume to be updated simultaneously
	7:0	ADCR_VOL [7:0]	1100_0000	Right ADC Digital Volume 00h = mute 01h = -71.625dB 02h = -71.250dB ...0.375dB steps C0h = 0dB (default) ... FFh = 23.625dB

Register 16h Right ADC volume

REGISTER ADDRESS	BIT	LABEL	DEFAULT	DESCRIPTION
R23 (17h) Additional control(1)	8	THERR_ACT	1	Speaker and Headphone over temperature shutdown enable. 0 = Disabled 1 = Enabled Note that TEMP_ENA_HP or TEMP_ENA_SPK or both must be enabled for Automatic Shutdown to work
	5	ADC_HP	0	ADC Oversampling Ratio 0 = Low Power (typically 64 x fs) 1 = High Performance (typically 128 x fs)
	0	TOCLK_ENA	0	TOCLK Enable 0 = Disabled 1 = Enabled

Register 17h Additional control(1)

REGISTER ADDRESS	BIT	LABEL	DEFAULT	DESCRIPTION
R24 (18h) Additional control(2)	3	AIF_TRI	0	Audio Interface Tristate 0 = Audio interface pins operate normally 1 = ADCDAT is tri-stated; BCLK & LRCLK are set as inputs

Register 18h Additional control(2)

REGISTER ADDRESS	BIT	LABEL	DEFAULT	DESCRIPTION
R25 (19h) Pwr Mgmt (1)	10	DMIC_ENA	0	Enables Digital Microphone mode. 0 = Audio DSP input is from ADC 1 = Audio DSP input is from digital microphone interface Note that, when the digital microphone interface is selected, the ADCL_ENA and ADCR_ENA registers must also be set to enable the left and right digital microphone channels respectively.
	9	OPCLK_ENA	0	GPIO Clock Output Enable 0 = Disabled 1 = Enabled
	8:7	VMID_SEL [1:0]	00	VMID Divider Enable and Select 00 = VMID disabled (for OFF mode) 01 = 2 x 50k divider (for normal operation) 10 = 2 x 250k divider (for low power standby) 11 = 2 x 5k divider (for fast start-up)
	6	BIAS_ENA	0	Enables the Normal bias current generator (for all analogue functions) 0 = Disabled 1 = Enabled
	5	INL_ENA	0	Left Input PGA and Mixer Enable. 0 = Disabled 1 = Enabled
	4	INR_ENA	0	Right Input PGA and Mixer Enable. 0 = Disabled 1 = Enabled
	3	ADCL_ENA	0	Left ADC Enable 0 = Disabled 1 = Enabled
	2	ADCR_ENA	0	Right ADC Enable 0 = Disabled 1 = Enabled
	1	MICBIAS_ENA	0	Microphone Bias Enable 0 = OFF (high impedance output) 1 = ON

Register 19h Pwr Mgmt (1)

REGISTER ADDRESS	BIT	LABEL	DEFAULT	DESCRIPTION
R26 (1Ah) Pwr Mgmt (2)	8	DACL_ENA	0	Left DAC Enable 0 = Disabled 1 = Enabled Note that DACL_ENA must be set to 1 when processing left channel data from the DAC or Digital Beep Generator.
	7	DACR_ENA	0	Right DAC Enable 0 = Disabled 1 = Enabled Note that DACR_ENA must be set to 1 when processing right channel data from the DAC or Digital Beep Generator.
	6	HPOUTL_PGA_ENA	0	Headphone Left PGA enable 0 = Disabled 1 = Enabled
	5	HPOUTR_PGA_ENA	0	Headphone Right PGA enable 0 = Disabled 1 = Enabled

REGISTER ADDRESS	BIT	LABEL	DEFAULT	DESCRIPTION
	4	SPKOUTL_PGA_ENA	0	Speaker Left PGA enable 0 = Disabled 1 = Enabled
	3	SPKOUTR_PGA_ENA	0	Speaker Right PGA enable 0 = Disabled 1 = Enabled
	1	HPOUTL_PGA_MUTE	0	HPOUTL_VOL (Left Headphone Output PGA) Mute 0 = Un-mute 1 = Mute
	0	HPOUTR_PGA_MUTE	0	HPOUTR_VOL (Right Headphone Output PGA) Mute 0 = Un-mute 1 = Mute

Register 1Ah Pwr Mgmt (2)

REGISTER ADDRESS	BIT	LABEL	DEFAULT	DESCRIPTION
R27 (1Bh) Additional Control (3)	4	SAMPLE_RATE_INT_MODE	1	Selects the Integer or Fractional value of the SAMPLE_RATE register. 0 = 11.025k, 22.05k, 44.1k or 88.2kHz 1 = 8k, 12k, 16k, 24k, 32k, 48k or 96kHz
	2:0	SAMPLE_RATE [2:0]	000	Selects the Sample Rate (fs) 000 = 44.1kHz, 48kHz 001 = 32kHz 010 = 22.05kHz, 24kHz 011 = 16kHz 100 = 11.025kHz, 12kHz 101 = 8kHz 110 = 88.2kHz, 96kHz 111 = Reserved

Register 1Bh Additional Control (3)

REGISTER ADDRESS	BIT	LABEL	DEFAULT	DESCRIPTION
R28 (1Ch) Anti-pop	4	STARTUP_BIAS_ENA	0	Enables the Start-Up bias current generator 0 = Disabled 1 = Enabled
	3	VMID_BUF_ENA	0	VMID Buffer Enable 0 = Disabled 1 = Enabled
	2	VMID_RAMP	0	Enables VMID soft ramp-up 0 = Disabled 1 = Enabled

Register 1Ch Anti-pop

REGISTER ADDRESS	BIT	LABEL	DEFAULT	DESCRIPTION
R29 (1Dh) Pwr Mgmt (3)	1:0	MICBIAS_EVR [1:0]	00	Microphone Bias Voltage Control 00 = Controlled by MICBIAS_LVL 01 = 1.63 x AVDD (approx.) 10 = 1.34 x AVDD (approx.) 11 = 1.63 x AVDD (approx.)

Register 1Dh Pwr Mgmt (3)

REGISTER ADDRESS	BIT	LABEL	DEFAULT	DESCRIPTION
R30 (1Eh) Clocking 3	15:13	DBCLK_DIV [2:0]	000	DBCLK Rate Divider (divides the 256kHz clock; nominal frequency is quoted in brackets) 000 = f / 256 (1kHz) 001 = f / 2048 (125Hz) 010 = f / 4096 (62.5Hz) 011 = f / 8192 (31.2Hz) 100 = f / 16384 (15.6Hz) 101 = f / 32768 (7.8Hz) 110 = f / 64536 (3.9Hz) 111 = f / 131072 (1.95Hz)
	12:10	OPCLK_DIV [2:0]	000	GPIO Output Clock Divider 000 = SYSCLK 001 = SYSCLK / 2 010 = SYSCLK / 3 011 = SYSCLK / 4 100 = SYSCLK / 6 101 = SYSCLK / 8 110 = SYSCLK / 12 111 = SYSCLK / 16 000 = SYSCLK / 16
	9:7	TOCLK_DIV [2:0]	000	TOCLK Rate Divider (divides the 256kHz clock; nominal frequency is quoted in brackets) 000 = f / 256 (1kHz) 001 = f / 512 (500Hz) 010 = f / 1024 (250Hz) 011 = f / 2048 (125Hz) 100 = f / 4096 (62.5Hz) 101 = f / 8192 (31.2Hz) 110 = f / 16384 (15.6Hz) 111 = f / 32768 (7.8Hz)
	6:1	F256KCLK_DIV [5:0]	10_1111	256kHz Clock Divider 0d = SYSCLK 1d = SYSCLK / 2 2d = SYSCLK / 3 63d = SYSCLK / 64 This field is for read-back only; it is set automatically and cannot be adjusted. <i>Protected by security key.</i>

Register 1Eh Clocking 3

REGISTER ADDRESS	BIT	LABEL	DEFAULT	DESCRIPTION
R31 (1Fh) Input mixer control (1)	3	MIXINL_MUTE	0	Left input boost mixer mute 0 = Un-mute 1 = Mute
	2	MIXINR_MUTE	0	Right input boost mixer mute 0 = Un-mute 1 = Mute
	1	MIXINL_ENA	0	Left Input Mixer Enable 0 = Disabled 1 = Enabled Note that the Left Input Mixer is also enabled when INL_ENA is set
	0	MIXINR_ENA	0	Right Input Mixer Enable 0 = Disabled 1 = Enabled Note that the Right Input Mixer is also enabled when INR_ENA is set

Register 1Fh Input mixer control (1)

REGISTER ADDRESS	BIT	LABEL	DEFAULT	DESCRIPTION
R32 (20h) Left input mixer volume	8:6	IN2L_MIXINL_V OL [2:0]	101	Left input IN2L to Left input Boost Mixer Gain 000 = -12dB 001 = -12dB 010 = -9dB 011 = -6dB 100 = -3dB 101 = 0dB 110 = +3dB 111 = +6dB
	5:3	INPGAL_MIXIN L_VOL [2:0]	000	Left input PGA to Left input Boost Mixer Gain 000 = 0dB 001 = +6dB 010 = +13dB 011 = +18dB 100 = +20dB 101 = +24dB 110 = +27dB 111 = +29dB
	2:0	IN3L_MIXINL_V OL [2:0]	101	Left input IN3L to Left input Boost Mixer Gain 000 = -12dB 001 = -12dB 010 = -9dB 011 = -6dB 100 = -3dB 101 = 0dB 110 = +3dB 111 = +6dB

Register 20h Left input mixer volume

REGISTER ADDRESS	BIT	LABEL	DEFAULT	DESCRIPTION
R33 (21h) Right input mixer volume	8:6	IN2R_MIXINR_VOL [2:0]	101	Right input IN2R to Right input Boost Mixer Gain 000 = -12dB 001 = -12dB 010 = -9dB 011 = -6dB 100 = -3dB 101 = 0dB 110 = +3dB 111 = +6dB
	5:3	INPGAR_MIXINR_VOL [2:0]	000	Right input PGA to Right input Boost Mixer Gain 000 = 0dB 001 = +6dB 010 = +13dB 011 = +18dB 100 = +20dB 101 = +24dB 110 = +27dB 111 = +29dB
	2:0	IN3R_MIXINR_VOL [2:0]	101	Right input IN3R to Right input Boost Mixer Gain 000 = -12dB 001 = -12dB 010 = -9dB 011 = -6dB 100 = -3dB 101 = 0dB 110 = +3dB 111 = +6dB

Register 21h Right input mixer volume

REGISTER ADDRESS	BIT	LABEL	DEFAULT	DESCRIPTION
R34 (22h) Input mixer control (2)	5	IN2L_TO_MIXINL	0	Left Input IN2L to Left input Boost Mixer Select 0 = Disabled 1 = Enabled
	4	IN3L_TO_MIXINL	0	Left Input IN3L to Left input Boost Mixer Select 0 = Disabled 1 = Enabled
	3	INPGAL_TO_MIXINL	1	Left Input PGA to Left input Boost Mixer Select 0 = Disabled 1 = Enabled
	2	IN2R_TO_MIXINR	0	Right input IN2R to Right input Boost Mixer Select 0 = Disabled 1 = Enabled
	1	IN3R_TO_MIXINR	0	Right input IN3R to Right input Boost Mixer Select 0 = Disabled 1 = Enabled
	0	INPGAR_TO_MIXINR	1	Right input PGA to Right input Boost Mixer Select 0 = Disabled 1 = Enabled

Register 22h Input mixer control (2)

REGISTER ADDRESS	BIT	LABEL	DEFAULT	DESCRIPTION
R35 (23h) Input bias control	5:3	MIXIN_BIAS [2:0]	000	Input Boost-Mixer Bias Control 000 = x 2.0 (default) 001 = Reserved 010 = Reserved 011 = x 1.0 100 = x 0.67 101 to 111 = Reserved
	2:0	INPGA_BIAS [2:0]	100	Input PGA Bias Control 000 = x 2.0 001 = Reserved 010 = Reserved 011 = Reserved 100 = x 0.67 (default) 101 to 111 = Reserved

Register 23h Input bias control

REGISTER ADDRESS	BIT	LABEL	DEFAULT	DESCRIPTION
R37 (25h) Left input PGA control	4	INPGAL_ENA	0	Left Input PGA Enable. 0 = Disabled 1 = Enabled Note that the Left Input PGA is also enabled when INL_ENA is set
	3	IN1L_TO_INPGAL	1	Selects the IN1L pin as an input to the left PGA 0 = Disabled 1 = Enabled
	2	IN2L_TO_INPGAL	0	Selects the IN2L pin as an input to the left PGA 0 = Disabled 1 = Enabled
	1	IN3L_TO_INPGAL	0	Selects the IN3L pin as an input to the left PGA 0 = Disabled 1 = Enabled
	0	IN4L_TO_INPGAL	0	Selects the IN4L pin as an input to the left PGA 0 = Disabled 1 = Enabled

Register 25h Left input PGA control

REGISTER ADDRESS	BIT	LABEL	DEFAULT	DESCRIPTION
R38 (26h) Right input PGA control	4	INPGAR_ENA	0	Right Input PGA Enable 0 = Disabled 1 = Enabled Note that the Right Input PGA is also enabled when INR_ENA is set
	3	IN1R_TO_INPGAR	1	Selects the IN1R pin as an input to the right PGA 0 = Disabled 1 = Enabled
	2	IN2R_TO_INPGAR	0	Selects the IN2R pin as an input to the right PGA 0 = Disabled 1 = Enabled
	1	IN3R_TO_INPGAR	0	Selects the IN3R pin as an input to the right PGA 0 = Disabled 1 = Enabled

REGISTER ADDRESS	BIT	LABEL	DEFAULT	DESCRIPTION
	0	IN4R_TO_INPGAR	0	Selects the IN4R pin as an input to the right PGA 0 = Disabled 1 = Enabled

Register 26h Right input PGA control

REGISTER ADDRESS	BIT	LABEL	DEFAULT	DESCRIPTION
R40 (28h) SPKOUTL volume	8	SPKOUT_VU	0	Speaker Output PGA Volume Update Writing a 1 to this bit will update SPKOUTL_VOL and SPKOUTR_VOL volumes simultaneously.
	7	SPKOUTL_ZC	0	SPKOUTL_VOL (Left Speaker Output PGA) Zero Cross Enable 0 = Zero cross disabled 1 = Zero cross enabled
	6:0	SPKOUTL_VOL [6:0]	000_0000	Left Speaker Output PGA Volume 000_0000 to 010_1111 = Mute 011_0000 to 011_0101 = -68dB 011_0110 = -67dB ...in 1dB steps 111_1001 = 0dB ... 111_1111 = +6dB

Register 28h SPKOUTL volume

REGISTER ADDRESS	BIT	LABEL	DEFAULT	DESCRIPTION
R41 (29h) SPKOUTR volume	8	SPKOUT_VU	0	Speaker Output PGA Volume Update Writing a 1 to this bit will update SPKOUTL_VOL and SPKOUTR_VOL volumes simultaneously.
	7	SPKOUTR_ZC	0	SPKOUTR_VOL (Right Speaker Output PGA) Zero Cross Enable 0 = Zero cross disabled 1 = Zero cross enabled
	6:0	SPKOUTR_VOL [6:0]	000_0000	Right Speaker Output PGA Volume 000_0000 to 010_1111 = Mute 011_0000 to 011_0101 = -68dB 011_0110 = -67dB ...in 1dB steps 111_1001 = 0dB ... 111_1111 = +6dB

Register 29h SPKOUTR volume

REGISTER ADDRESS	BIT	LABEL	DEFAULT	DESCRIPTION
R47 (2Fh) Thermal Shutdown Status	3	TEMP_ERR_HP	0	Headphone temperature error status (triggered at 145°C) 0 = Not triggered 1 = Triggered Note that this is a Read Only field
	2	TEMP_WARN_HP	0	Headphone temperature warning status (triggered at 125°C) 0 = Not triggered 1 = Triggered Note that this is a Read Only field
	1	TEMP_ERR_SPK	0	Speaker temperature error status (triggered at 145°C) 0 = Not triggered 1 = Triggered Note that this is a Read Only field
	0	TEMP_WARN_SPK	0	Speaker temperature warning status (triggered at 125°C) 0 = Not triggered 1 = Triggered Note that this is a Read Only field

Register 2Fh Thermal Shutdown Status

REGISTER ADDRESS	BIT	LABEL	DEFAULT	DESCRIPTION
R48 (30h) Additional Control (4)	15	Reserved	1	Reserved - do not change
	14:12	MICDET_THR [2:0]	000	MICBIAS Current Detect Threshold (AVDD = 1.8V) 000 = 64uA 001 = 166uA 010 = 375uA 011 = 475uA 100 = 575uA 101 = 680uA 110 = 885uA 111 = 990uA Note that the value scales with AVDD. The value quoted is correct for AVDD=1.8V
	11:10	MICSHORT_THR [1:0]	00	MICBIAS Short Circuit Threshold (AVDD = 1.8V) 00 = 515uA 01 = 680uA 10 = 1050uA 11 = 1215uA Note that the value scales with AVDD. The value quoted is correct for AVDD=1.8V
	9	MICDET_ENA	0	MICBIAS Current and Short Circuit Detect Enable 0 = Disabled 1 = Enabled
	7	MICDET_STS	0	MICBIAS Current Detection status 0 = Current Detect threshold not exceeded 1 = Current Detect threshold exceeded
	6	MICSHORT_STS	0	MICBIAS Short Circuit status 0 = Short Circuit threshold not exceeded 1 = Short Circuit threshold exceeded
	5	Reserved	1	Reserved - do not change
	2	TEMP_ENA_HP	1	Headphone temperature sensor enable 0 = Disabled 1 = Enabled

REGISTER ADDRESS	BIT	LABEL	DEFAULT	DESCRIPTION
	1	TEMP_ENA_SPK	1	Speaker temperature sensor enable 0 = Disabled 1 = Enabled
	0	MICBIAS_LVL	1	Microphone Bias Voltage Control 0 = 0.828 x AVDD (approx.) 1 = 1.156 x AVDD (approx.) Only valid when MICBIAS_EVR=00. In other cases, the Microphone Bias voltage is controlled by MICBIAS_EVR alone.

Register 30h Additional Control (4)

REGISTER ADDRESS	BIT	LABEL	DEFAULT	DESCRIPTION
R49 (31h) Class D Control 1	7	SPKOUTR_ENA	0	Right channel class D Speaker Enable 0 = Disabled 1 = Enabled
	6	SPKOUTL_ENA	0	Left channel class D Speaker Enable 0 = Disabled 1 = Enabled
	4	DAC_MUTE	1	Digital DAC Mute 0 = Un-mute 1 = Mute Note that this bit also exists in R5. Reading or writing to either location has the same effect.
	2	SPKOUT_VU	0	Speaker Output PGA Volume Update Writing a 1 to this bit will update SPKOUTL_VOL and SPKOUTR_VOL volumes simultaneously.
	1	SPKOUTL_PGA_MUTE	0	SPKOUTL_VOL (Left Speaker Output PGA) Mute 0 = Un-mute 1 = Mute
	0	SPKOUTR_PGA_MUTE	0	SPKOUTR_VOL (Right Speaker Output PGA) Mute 0 = Un-mute 1 = Mute

Register 31h Class D Control 1

REGISTER ADDRESS	BIT	LABEL	DEFAULT	DESCRIPTION
R51 (33h) Class D Control 2	6	SPK_MONO	0	Mono Speaker Configuration enable 0 = Default (stereo) 1 = Mono mode When SPK_MONO is set to '1', both speakers output the signal from the left channel. Note that the user must tie the outputs together for mono use
	2:0	CLASSD_VOL [2:0]	011	AC Speaker Gain Boost. Note that both left and right channels are boosted equally 000 = 1.00x boost (+0dB) 001 = 1.19x boost (+1.5dB) 010 = 1.41x boost (+3.0dB) 011 = 1.68x boost (+4.5dB) 100 = 2.00x boost (+6.0dB) 101 = 2.37x boost (+7.5dB) 110 = 2.81x boost (+9.0dB) 111 = 3.98x boost (+12.0dB)

Register 33h Class D Control 2

REGISTER ADDRESS	BIT	LABEL	DEFAULT	DESCRIPTION
R56 (38h) Clocking 4	4:1	MCLK_RATE [3:0]	0011	Selects the MCLK / fs ratio. (Note that the MCLK source is selected by MCLK_SRC.) 0000 = 64 0001 = 128 0010 = 192 0011 = 256 (default) 0100 = 384 0101 = 512 0110 = 768 0111 = 1024 1000 = Reserved 1001 = 1536 1010 = 3072 1011 = 6144 1100 to 1111 = Reserved If ADC ReTune, DAC ReTune, DAC HPF, VSS or HD Bass is enabled, then MCLK_RATE must be 512 or higher

Register 38h Clocking 4

REGISTER ADDRESS	BIT	LABEL	DEFAULT	DESCRIPTION
R57 (39h) DAC DSP Mixing (1)	9	DAC_MONOMIX	0	DAC Mono Mix 0 = Stereo 1 = Mono (Mono mix output on enabled DAC) Mono Mix is only supported when one or other DAC is disabled. When Mono mix is enabled, 6dB attenuation is applied.
	7:4	ADCR_DAC_SVOL [3:0]	0000	Right ADC Digital Sidetone Volume 0000 = -36dB 0001 = -33dB (... 3dB steps) 1011 = -3dB 11XX = 0dB
	3:2	ADC_TO_DACR [1:0]	00	Right DAC Digital Sidetone Source 00 = No sidetone 01 = Left ADC 10 = Right ADC 11 = No sidetone

Register 39h DAC DSP Mixing (1)

REGISTER ADDRESS	BIT	LABEL	DEFAULT	DESCRIPTION
R58 (3Ah) DAC DSP Mixing (2)	7:4	ADCL_DAC_SVOL [3:0]	0000	Left ADC Digital Sidetone Volume 0000 = -36dB 0001 = -33dB (... 3dB steps) 1011 = -3dB 11XX = 0dB
	3:2	ADC_TO_DACL [1:0]	00	Left DAC Digital Sidetone Source 00 = No sidetone 01 = Left ADC

REGISTER ADDRESS	BIT	LABEL	DEFAULT	DESCRIPTION
				10 = Right ADC 11 = No sidetone

Register 3Ah DAC DSP Mixing (2)

REGISTER ADDRESS	BIT	LABEL	DEFAULT	DESCRIPTION
R60 (3Ch) DC Servo 0	7	INL_DCS_ENA	0	DC Servo enable for Left input signal path 0 = Disabled 1 = Enabled
	6	INL_DCS_STARTUP	0	Writing 1 to this bit selects Start-Up DC Servo mode for Left input signal path
	3	INR_DCS_ENA	0	DC Servo enable for Right input signal path 0 = Disabled 1 = Enabled
	2	INR_DCS_STARTUP	0	Writing 1 to this bit selects Start-Up DC Servo mode for Right input signal path

Register 3Ch DC Servo 0

REGISTER ADDRESS	BIT	LABEL	DEFAULT	DESCRIPTION
R61 (3Dh) DC Servo 1	7	HP1L_DCS_ENA	0	DC Servo enable for HPOUTL 0 = Disabled 1 = Enabled
	6	HP1L_DCS_STARTUP	0	Writing 1 to this bit selects Start-Up DC Servo mode for HPOUTL
	4	HP1L_DCS_SYNC	0	Writing 1 to this bit selects a series of DC offset corrections for HPOUTL
	3	HP1R_DCS_ENA	0	DC Servo enable for HPOUTR 0 = Disabled 1 = Enabled
	2	HP1R_DCS_STARTUP	0	Writing 1 to this bit selects Start-Up DC Servo mode for HPOUTR
	0	HP1R_DCS_SYNC	0	Writing 1 to this bit selects a series of DC offset corrections for HPOUTR

Register 3Dh DC Servo 1

REGISTER ADDRESS	BIT	LABEL	DEFAULT	DESCRIPTION
R64 (40h) DC Servo 4	13:7	HP1_DCS_SYNC_STEPS [6:0]	001_0000	Number of DC Servo updates to perform in a series event (HPOUTL and HPOUTR) 00h to 0Fh = Reserved 10h = 16 (default) 11h = 17 ... 7Fh = 127

Register 40h DC Servo 4

REGISTER ADDRESS	BIT	LABEL	DEFAULT	DESCRIPTION
R66 (42h)	10	DCS_STARTUP	0	DC Servo Start-Up Status (Left Input)

REGISTER ADDRESS	BIT	LABEL	DEFAULT	DESCRIPTION
DC Servo 6		_DONE_INL		0 = Not complete 1 = Complete
	9	DCS_STARTUP_DONE_INR	0	DC Servo Start-Up Status (Right Input) 0 = Not complete 1 = Complete
	8	DCS_STARTUP_DONE_HP1L	0	DC Servo Start-Up Status (HPOUTL) 0 = Not complete 1 = Complete
	7	DCS_STARTUP_DONE_HP1R	0	DC Servo Start-Up Status (HPOUTR) 0 = Not complete 1 = Complete

Register 42h DC Servo 6

REGISTER ADDRESS	BIT	LABEL	DEFAULT	DESCRIPTION
R68 (44h) Analogue PGA Bias	4	Reserved	1	Reserved - do not change
	3	Reserved	1	Reserved - do not change
	2:0	HP_PGAS_BIAS [2:0]	011	Headphone PGA Boost Bias 000 = x 2.0 001 = Reserved 010 = Reserved 011 = x 1.0 (default) 100 to 111 = Reserved

Register 44h Analogue PGA Bias

REGISTER ADDRESS	BIT	LABEL	DEFAULT	DESCRIPTION
R69 (45h) Analogue HP 0	7	HP1L_RMV_SHORT	0	Removes HP1L short 0 = HP1L short enabled 1 = HP1L short removed For pop-free operation, this bit should be set to 1 as the final step in the HP1L Enable sequence.
	6	HP1L_ENA_OUTPUT	0	Enables HP1L output stage 0 = Disabled 1 = Enabled For pop-free operation, this bit should be set to 1 after the DC offset cancellation has been performed.
	5	HP1L_ENA_DELAY	0	Enables HP1L intermediate stage 0 = Disabled 1 = Enabled For pop-free operation, this bit should be set to 1 after the output signal path has been configured, and before the DC Offset cancellation is scheduled. This bit should be set with at least 20us delay after HP1L_ENA.
	4	HP1L_ENA	0	Enables HP1L input stage 0 = Disabled 1 = Enabled For pop-free operation, this bit should be set as the first stage of the HP1L Enable sequence.
	3	HP1R_RMV_SHORT	0	Removes HP1R short 0 = HP1R short enabled 1 = HP1R short removed For pop-free operation, this bit should be set to 1 as the

REGISTER ADDRESS	BIT	LABEL	DEFAULT	DESCRIPTION
				final step in the HP1R Enable sequence.
	2	HP1R_ENA_OUTP	0	Enables HP1R output stage 0 = Disabled 1 = Enabled For pop-free operation, this bit should be set to 1 after the DC offset cancellation has been performed.
	1	HP1R_ENA_DELAY	0	Enables HP1R intermediate stage 0 = Disabled 1 = Enabled For pop-free operation, this bit should be set to 1 after the output signal path has been configured, and before the DC Offset cancellation is scheduled This bit should be set with at least 20us delay after HP1R_ENA.
	0	HP1R_ENA	0	Enables HP1R input stage 0 = Disabled 1 = Enabled For pop-free operation, this bit should be set as the first stage of the HP1R Enable sequence.

Register 45h Analogue HP 0

REGISTER ADDRESS	BIT	LABEL	DEFAULT	DESCRIPTION
R71 (47h) Analogue HP 2	8:6	HP1L_VOL [2:0]	111	Headphone 1 Left Secondary PGA volume. 000 = -7dB 001 = -6dB 010 = -5dB 011 = -4dB 100 = -3dB 101 = -2dB 110 = -1dB 111 = 0dB (default)
	5:3	HP1R_VOL [2:0]	111	Headphone 1 Right Secondary PGA volume. 000 = -7dB 001 = -6dB 010 = -5dB 011 = -4dB 100 = -3dB 101 = -2dB 110 = -1dB 111 = 0dB (default)
	2:0	HP_BIAS_BOOST [2:0]	011	Headphone Driver Boost Bias 000 = x 2.0 001 = Reserved 010 = Reserved 011 = x 1.0 (default) 100 to 111 = Reserved

Register 47h Analogue HP 2

REGISTER ADDRESS	BIT	LABEL	DEFAULT	DESCRIPTION
R72 (48h) Charge Pump 1	0	CP_ENA	0	Enable charge-pump digits 0 = disable 1 = enable

Register 48h Charge Pump 1

REGISTER ADDRESS	BIT	LABEL	DEFAULT	DESCRIPTION
R82 (52h) Charge Pump B	0	CP_DYN_PWR	0	Enable dynamic charge pump power control 0 = Charge pump controlled by volume register settings (Class G) 1 = Charge pump controlled by real-time audio level (Class W) Class W is recommended for lowest power consumption When selecting CP_DYN_PWR=0, a '1' must be written to the HPOUT_VU bit (Register R2 or R3) to complete the mode change.

Register 52h Charge Pump B

REGISTER ADDRESS	BIT	LABEL	DEFAULT	DESCRIPTION
R87 (57h) Write Sequencer Control 1	7	WSEQ_AUTOS_EQ_ENA	0	Write Sequencer Auto-Sequence Enable (controls the Class D driver via DAC Auto-Mute function) 0 = Disabled 1 = Enabled
	5	WSEQ_ENA	0	Write Sequencer Enable. 0 = Disabled 1 = Enabled

Register 57h Write Sequencer Control 1

REGISTER ADDRESS	BIT	LABEL	DEFAULT	DESCRIPTION
R90 (5Ah) Write Sequencer Control 2	8	WSEQ_ABORT	0	Writing a 1 to this bit aborts the current sequence and returns control of the device back to the serial control interface.
	7	WSEQ_START	0	Writing a 1 to this bit starts the write sequencer at the index location selected by WSEQ_START_INDEX. The sequence continues until it reaches an "End of sequence" flag. At the end of the sequence, this bit will be reset by the Write Sequencer.
	6:0	WSEQ_START_INDEX [6:0]	000_0000	Sequence Start Index. This field determines the memory location of the first command in the selected sequence. There are 127 Write Sequencer RAM addresses: 00h = WSEQ_ADDR0 (R4096) 01h = WSEQ_ADDR1 (R4100) 02h = WSEQ_ADDR2 (R4104) 7Fh = WSEQ_ADDR127 (R4604)

Register 5Ah Write Sequencer Control 2

REGISTER ADDRESS	BIT	LABEL	DEFAULT	DESCRIPTION
R93 (5Dh) Write Sequencer Control 3	9:3	WSEQ_CURRENT_INDEX [6:0]	000_0000	Sequence Current Index. This indicates the memory location of the most recently accessed command in the write sequencer memory. Coding is the same as WSEQ_START_INDEX.
	0	WSEQ_BUSY	0	Sequencer Busy flag (Read Only). 0 = Sequencer idle 1 = Sequencer busy Note: it is not possible to write to non-PLL control registers

REGISTER ADDRESS	BIT	LABEL	DEFAULT	DESCRIPTION
				via the control interface while the Sequencer is Busy.

Register 5Dh Write Sequencer Control 3

REGISTER ADDRESS	BIT	LABEL	DEFAULT	DESCRIPTION
R94 (5Eh) Control Interface	6	SPI_CONTRD	0	Enable continuous read mode in SPI (3-wire/4-wire) modes 0 = Disabled 1 = Enabled
	5	SPI_4WIRE	0	SPI control mode select 0 = 3-wire using bidirectional SDA 1 = 4-wire using SDOOUT
	4	SPI_CFG	0	SDA/SDOOUT pin configuration In 3-wire mode (SPI_4WIRE=0): 0 = SDA output is CMOS 1 = SDA output is Open Drain In 4-wire mode (SPI_4WIRE=1): 0 = SDOOUT output is CMOS 1 = SDOOUT output is Wired 'OR'. Note that only GPIO5 can be configured as Wired 'OR'. This bit has no effect on GPIO2 or GPIO3.

Register 5Eh Control Interface

REGISTER ADDRESS	BIT	LABEL	DEFAULT	DESCRIPTION
R99 (63h) Mixer Enables	3	HPMIXL_ENA	0	Left Headphone Mixer Enable 0 = Disabled 1 = Enabled
	2	HPMIXR_ENA	0	Right Headphone Mixer Enable 0 = Disabled 1 = Enabled
	1	SPKMIXL_ENA	0	Left Speaker Mixer Enable 0 = Disabled 1 = Enabled
	0	SPKMIXR_ENA	0	Right Speaker Mixer Enable 0 = Disabled 1 = Enabled

Register 63h Mixer Enables

REGISTER ADDRESS	BIT	LABEL	DEFAULT	DESCRIPTION
R100 (64h) Headphone Mixer (1)	7	HPMIXL_TO_H POUTL_PGA	0	Left Headphone PGA Path Select 0 = DACL Output 1 = HPMIXL Output
	5	DACL_TO_HPMIXL	0	Left DAC to Left Headphone Mixer select 0 = Disabled 1 = Enabled
	4	DACR_TO_HPMIXL	0	Right DAC to Left Headphone Mixer select 0 = Disabled 1 = Enabled

REGISTER ADDRESS	BIT	LABEL	DEFAULT	DESCRIPTION
	3	MIXINL_TO_HP MIXL	0	Left Input Mixer to Left Headphone Mixer select 0 = Disabled 1 = Enabled
	2	MIXINR_TO_HP MIXL	0	Right Input Mixer to Left Headphone Mixer select 0 = Disabled 1 = Enabled
	1	IN4L_TO_HPMI XL	0	Input IN4L to Left Headphone Mixer select 0 = Disabled 1 = Enabled
	0	IN4R_TO_HPMI XL	0	Input IN4R to Left Headphone Mixer select 0 = Disabled 1 = Enabled

Register 64h Headphone Mixer (1)

REGISTER ADDRESS	BIT	LABEL	DEFAULT	DESCRIPTION
R101 (65h) Headphone Mixer (2)	7	HPMIXR_TO_H POUTR_PGA	0	Right Headphone PGA Path Select 0 = DACR Output 1 = HPMIXR Output
	5	DACL_TO_HP IXR	0	Left DAC to Right Headphone Mixer select 0 = Disabled 1 = Enabled
	4	DACR_TO_HP MIXR	0	Right DAC to Right Headphone Mixer select 0 = Disabled 1 = Enabled
	3	MIXINL_TO_HP MIXR	0	Left Input Mixer to Right Headphone Mixer select 0 = Disabled 1 = Enabled
	2	MIXINR_TO_HP MIXR	0	Right Input Mixer to Right Headphone Mixer select 0 = Disabled 1 = Enabled
	1	IN4L_TO_HPMI XR	0	Input IN4L to Right Headphone Mixer select 0 = Disabled 1 = Enabled
	0	IN4R_TO_HPMI XR	0	Input IN4R to Right Headphone Mixer select 0 = Disabled 1 = Enabled

Register 65h Headphone Mixer (2)

REGISTER ADDRESS	BIT	LABEL	DEFAULT	DESCRIPTION
R102 (66h) Headphone Mixer (3)	8	HPMIXL_MUTE	1	Left Headphone Mixer Mute 0 = Unmuted 1 = Muted
	7	MIXINL_HPMIX L_VOL	0	Left Input Mixer to Left Headphone Mixer volume 0 = 0dB 1 = -6dB
	6	MIXINR_HPMIX L_VOL	0	Right Input Mixer to Left Headphone Mixer volume 0 = 0dB 1 = -6dB
	5:3	IN4L_HPMIXL_ VOL [2:0]	111	Input IN4L to Left Headphone Mixer Volume control 000 = -15dB

REGISTER ADDRESS	BIT	LABEL	DEFAULT	DESCRIPTION
				001 = -12dB 010 = -9dB 011 = -6dB 100 = -3dB 101 = 0dB 110 = +3dB 111 = +6dB
	2:0	IN4R_HPMIXL_VOL [2:0]	111	Input IN4R to Left Headphone Mixer Volume control 000 = -15dB 001 = -12dB 010 = -9dB 011 = -6dB 100 = -3dB 101 = 0dB 110 = +3dB 111 = +6dB

Register 66h Headphone Mixer (3)

REGISTER ADDRESS	BIT	LABEL	DEFAULT	DESCRIPTION
R103 (67h) Headphone Mixer (4)	8	HPMIXR_MUTE	1	Right Headphone Mixer Mute 0 = Unmuted 1 = Muted
	7	MIXINL_HPMIXR_VOL	0	Left Input Mixer to Right Headphone Mixer volume 0 = 0dB 1 = -6dB
	6	MIXINR_HPMIXR_VOL	0	Right Input Mixer to Right Headphone Mixer volume 0 = 0dB 1 = -6dB
	5:3	IN4L_HPMIXR_VOL [2:0]	111	Input IN4L to Right Headphone Mixer Volume control 000 = -15dB 001 = -12dB 010 = -9dB 011 = -6dB 100 = -3dB 101 = 0dB 110 = +3dB 111 = +6dB
	2:0	IN4R_HPMIXR_VOL [2:0]	111	Input IN4R to Right Headphone Mixer Volume control 000 = -15dB 001 = -12dB 010 = -9dB 011 = -6dB 100 = -3dB 101 = 0dB 110 = +3dB 111 = +6dB

Register 67h Headphone Mixer (4)

REGISTER ADDRESS	BIT	LABEL	DEFAULT	DESCRIPTION
R105 (69h) Speaker	7	SPKMIXL_TO_SPKOUTL_PGA	0	Left Speaker PGA Path Select 0 = DACL Output

REGISTER ADDRESS	BIT	LABEL	DEFAULT	DESCRIPTION
Mixer (1)				1 = SPKMIXL Output
	5	DACL_TO_SPK MIXL	0	Left DAC to Left Speaker Mixer select 0 = Disabled 1 = Enabled
	4	DACR_TO_SPK MIXL	0	Right DAC to Left Speaker Mixer select 0 = Disabled 1 = Enabled
	3	MIXINL_TO_SP KMIXL	0	Left Input Mixer to Left Speaker Mixer select 0 = Disabled 1 = Enabled
	2	MIXINR_TO_SP KMIXL	0	Right Input Mixer to Left Speaker Mixer select 0 = Disabled 1 = Enabled
	1	IN4L_TO_SPKM IXL	0	Input IN4L to Left Speaker Mixer select 0 = Disabled 1 = Enabled
	0	IN4R_TO_SPK MIXL	0	Input IN4R to Left Speaker Mixer select 0 = Disabled 1 = Enabled

Register 69h Speaker Mixer (1)

REGISTER ADDRESS	BIT	LABEL	DEFAULT	DESCRIPTION
R106 (6Ah) Speaker Mixer (2)	7	SPKMIXR_TO_SPKOUTR_PGA	0	Right Speaker PGA Path Select 0 = DACR Output 1 = SPKMIXR Output
	5	DACL_TO_SPK MIXR	0	Left DAC to Right Speaker Mixer select 0 = Disabled 1 = Enabled
	4	DACR_TO_SPK MIXR	0	Right DAC to Right Speaker Mixer select 0 = Disabled 1 = Enabled
	3	MIXINL_TO_SP KMIXR	0	Left Input Mixer to Right Speaker Mixer select 0 = Disabled 1 = Enabled
	2	MIXINR_TO_SP KMIXR	0	Right Input Mixer to Right Speaker Mixer select 0 = Disabled 1 = Enabled
	1	IN4L_TO_SPKM IXR	0	Input IN4L to Right Speaker Mixer select 0 = Disabled 1 = Enabled
	0	IN4R_TO_SPK MIXR	0	Input IN4R to Right Speaker Mixer select 0 = Disabled 1 = Enabled

Register 6Ah Speaker Mixer (2)

REGISTER ADDRESS	BIT	LABEL	DEFAULT	DESCRIPTION
R107 (6Bh) Speaker Mixer (3)	8	SPKMIXL_MUTE	1	Left Speaker Mixer Mute 0 = Unmuted 1 = Muted
	7	MIXINL_SPKMI	0	Left Input Mixer to Left Speaker Mixer volume

REGISTER ADDRESS	BIT	LABEL	DEFAULT	DESCRIPTION
		XL_VOL		0 = 0dB 1 = -6dB
	6	MIXINR_SPKMI XL_VOL	0	Right Input Mixer to Left Speaker Mixer volume 0 = 0dB 1 = -6dB
	5:3	IN4L_SPKMIXL _VOL [2:0]	111	Input IN4L to Left Speaker Mixer Volume control 000 = -15dB 001 = -12dB 010 = -9dB 011 = -6dB 100 = -3dB 101 = 0dB 110 = +3dB 111 = +6dB
	2:0	IN4R_SPKMIXL _VOL [2:0]	111	Input IN4R to Left Speaker Mixer Volume control 000 = -15dB 001 = -12dB 010 = -9dB 011 = -6dB 100 = -3dB 101 = 0dB 110 = +3dB 111 = +6dB

Register 6Bh Speaker Mixer (3)

REGISTER ADDRESS	BIT	LABEL	DEFAULT	DESCRIPTION
R108 (6Ch) Speaker Mixer (4)	8	SPKMIXR_MUT E	1	Right Speaker Mixer Mute 0 = Unmuted 1 = Muted
	7	MIXINL_SPKMI XR_VOL	0	Left Input Mixer to Right Speaker Mixer volume 0 = 0dB 1 = -6dB
	6	MIXINR_SPKMI XR_VOL	0	Right Input Mixer to Right Speaker Mixer volume 0 = 0dB 1 = -6dB
	5:3	IN4L_SPKMIXR _VOL [2:0]	111	Input IN4L to Right Speaker Mixer Volume control 000 = -15dB 001 = -12dB 010 = -9dB 011 = -6dB 100 = -3dB 101 = 0dB 110 = +3dB 111 = +6dB
	2:0	IN4R_SPKMIXR _VOL [2:0]	111	Input IN4R to Right Speaker Mixer Volume control 000 = -15dB 001 = -12dB 010 = -9dB 011 = -6dB 100 = -3dB 101 = 0dB 110 = +3dB 111 = +6dB

Register 6Ch Speaker Mixer (4)

REGISTER ADDRESS	BIT	LABEL	DEFAULT	DESCRIPTION
R109 (6Dh) Speaker Mixer (5)	7	DACL_SPKMIX_L_VOL	0	Left DAC to Left Speaker Mixer volume 0 = 0dB 1 = -6dB
	6	DACR_SPKMIX_L_VOL	0	Right DAC to Left Speaker Mixer volume 0 = 0dB 1 = -6dB
	5	DACL_SPKMIX_R_VOL	0	Left DAC to Right Speaker Mixer volume 0 = 0dB 1 = -6dB
	4	DACR_SPKMIX_R_VOL	0	Right DAC to Right Speaker Mixer volume 0 = 0dB 1 = -6dB
	1	Reserved	1	Reserved - do not change
	0	Reserved	1	Reserved - do not change

Register 6Dh Speaker Mixer (5)

REGISTER ADDRESS	BIT	LABEL	DEFAULT	DESCRIPTION
R110 (6Eh) Beep Generator (1)	7:4	BEEP_GAIN [3:0]	0000	Digital Beep Volume Control 0000 = mute 0001 = -90dB 0010 = -84dB ... (6dB steps) 1111 = -6dB
	2:1	BEEP_RATE [1:0]	01	Digital Beep Waveform Control If SAMPLE_RATE_INT_MODE = 1 00 = 500Hz 01 = 1000Hz 10 = 2000Hz 11 = 4000Hz If SAMPLE_RATE_INT_MODE = 0 00 = 499 – 502Hz 01 = 999 – 1003Hz 10 = 1998 – 2005Hz 11 = 3997 – 4009Hz
	0	BEEP_ENA	0	Digital Beep Enable 0 = Disabled 1 = Enabled Note that the DAC and associated signal path needs to be enabled when using the digital beep.

Register 6Eh Beep Generator (1)

REGISTER ADDRESS	BIT	LABEL	DEFAULT	DESCRIPTION
R115 (73h) Oscillator Trim (3)	4:0	OSC_TRIM_XTI [4:0]	0_0000	Trimmed Oscillator XTI capacitance 00h = 8pF 01h = 8.5pF ... 0.5pF steps 1Eh = 23pF 1Fh = 23.5pF This field is for read-back only; it is set automatically and cannot be adjusted.

REGISTER ADDRESS	BIT	LABEL	DEFAULT	DESCRIPTION
				<i>Protected by security key.</i>

Register 73h Oscillator Trim (3)

REGISTER ADDRESS	BIT	LABEL	DEFAULT	DESCRIPTION
R116 (74h) Oscillator Trim (4)	4:0	OSC_TRIM_XTO O [4:0]	0_0000	Trimmed Oscillator XTO capacitance 00h = 8pF 01h = 8.5pF ... 0.5pF steps 1Eh = 23pF 1Fh = 23.5pF This field is for read-back only; it is set automatically and cannot be adjusted. <i>Protected by security key.</i>

Register 74h Oscillator Trim (4)

REGISTER ADDRESS	BIT	LABEL	DEFAULT	DESCRIPTION
R119 (77h) Oscillator Trim (7)	7:4	XTO_CAP_SEL [3:0]	0000	XTO load capacitance adjustment Two's complement format, LSB = 0.5pF Range is -4.0pF to +3.5pF
	3:0	XTI_CAP_SEL [3:0]	0000	XTI load capacitance adjustment Two's complement format, LSB = 0.5pF Range is -4.0pF to +3.5pF

Register 77h Oscillator Trim (7)

REGISTER ADDRESS	BIT	LABEL	DEFAULT	DESCRIPTION
R124 (7Ch) Analogue Clocking1	6:5	CLKOUT2_SEL [1:0]	00	CLKOUT2 Output Select 00 = PLL2 01 = GPIO2 10 = Internal oscillator 11 = Reserved
	4:3	CLKOUT3_SEL [1:0]	10	CLKOUT3 Output Select 00 = PLL3 01 = GPIO3 10 = FLL 11 = Reserved If CLKREG_OVD = 0, then CLKOUT3_SEL = 10 (FLL) and cannot be changed by the Control Interface. If CLKREG_OVD = 1, then CLKOUT3_SEL = 00 (PLL3) by default, but the value can be changed via the Control Interface.
	0	CLKOUT5_SEL	1	CLKOUT5 Output Select 0 = Internal oscillator 1 = FLL If CLKREG_OVD = 0, then CLKOUT5_SEL is controlled by the GPIO5 pin. If CLKREG_OVD = 0 and GPIO5 = 0, then CLKOUT5_SEL = 1 (FLL) and cannot be changed by the Control Interface.

REGISTER ADDRESS	BIT	LABEL	DEFAULT	DESCRIPTION
				<p>If CLKREG_OVD = 0 and GPIO5 = 1, then CLKOUT5_SEL = 0 (Oscillator) by default, but the value can be changed via the Control Interface.</p> <p>If CLKREG_OVD = 1 then CLKOUT5_SEL = 0 (Oscillator) by default, but the value can be changed via the Control Interface.</p>

Register 7Ch Analogue Clocking1

REGISTER ADDRESS	BIT	LABEL	DEFAULT	DESCRIPTION
R125 (7Dh) Analogue Clocking2	7	PLL2_OUTDIV	0	PLL2 Output Divider 0 = Divide by 2 1 = Divide by 4
	6	PLL3_OUTDIV	1	PLL3 Output Divider 0 = Divide by 2 1 = Divide by 4
	4:3	PLL_SYSCLK_DIV [1:0]	01	PLL3 / Oscillator to MCLK divider 00 = Divide by 1 01 = Divide by 2 10 = Divide by 4 11 = Reserved
	2	CLKOUT3_DIV	0	CLKOUT3 Output Divide 0 = Divide by 1 1 = Divide by 2
	1	CLKOUT2_DIV	1	CLKOUT2 Output Divide 0 = Divide by 1 1 = Divide by 2 If CLKREG_OVD = 0, then CLKOUT2_DIV = 1 (Divide by 2) and cannot be changed by the Control Interface. If CLKREG_OVD = 1, then CLKOUT2_DIV = 0 by default, but the value can be changed via the Control Interface.
	0	CLKOUT5_DIV	1	CLKOUT5 Output Divide 0 = Divide by 1 1 = Divide by 2 If CLKREG_OVD = 0, then CLKOUT5_DIV = 1 (Divide by 2) and cannot be changed by the Control Interface. If CLKREG_OVD = 1, then CLKOUT5_DIV = 0 by default, but the value can be changed via the Control Interface.

Register 7Dh Analogue Clocking2

REGISTER ADDRESS	BIT	LABEL	DEFAULT	DESCRIPTION
R126 (7Eh) Analogue Clocking3	4	Reserved	1	Reserved - do not change
	3	CLKOUT2_OE	1	CLKOUT2 Output Enable 0 = Disabled (tri-state) 1 = Enabled
	2	CLKOUT3_OE	1	CLKOUT3 Output Enable 0 = Disabled (tri-state) 1 = Enabled
	1	Reserved	1	Reserved - do not change
	0	CLKOUT5_OE	1	CLKOUT5 Output Enable 0 = Disabled (tri-state) 1 = Enabled

Register 7Eh Analogue Clocking3

REGISTER ADDRESS	BIT	LABEL	DEFAULT	DESCRIPTION
R127 (7Fh) PLL Software Reset	15:0	SW_RESET_PL L [15:0]	0000_0000 _0000_000 0	Writing to this register resets all PLL registers to their default state. This affects registers R114 (72h) through to R152 (98h)

Register 7Fh PLL Software Reset

REGISTER ADDRESS	BIT	LABEL	DEFAULT	DESCRIPTION
R129 (81h) PLL2	7	OSC_ENA	0	Internal Oscillator Enable 0 = Disabled 1 = Enabled If CLKREG_OVD = 0 and GPIO5 = 0, then OSC_ENA = 0 and cannot be changed by the Control Interface If CLKREG_OVD = 0 and GPIO5 = 1, then OSC_ENA = 1 by default, but the value can be changed via the Control Interface If CLKREG_OVD = 1 then OSC_ENA = 1 by default, but the value can be changed via the Control Interface
	5	PLL2_ENA	0	PLL2 Enable 0 = Disabled 1 = Enabled If CLKREG_OVD = 0, then PLL2_ENA = 0 (Disabled) and cannot be changed by the Control Interface. If CLKREG_OVD = 1, then PLL2_ENA = 1 by default, but the value can be changed via the Control Interface.
	4	PLL3_ENA	0	PLL3 Enable 0 = Disabled 1 = Enabled If CLKREG_OVD = 0, then PLL3_ENA = 0 (Disabled) and cannot be changed by the Control Interface. If CLKREG_OVD = 1, then PLL3_ENA = 1 by default, but the value can be changed via the Control Interface.
	0	Reserved	1	Reserved - do not change

Register 81h PLL2

REGISTER ADDRESS	BIT	LABEL	DEFAULT	DESCRIPTION
R131 (83h) PLL 4	4	Reserved	1	Reserved - do not change
	1	PLL_CLK_SRC	0	PLL Clock Source 0 = Internal oscillator 1 = MCLK Note that the SEQ_ENA bit (Register R150, 96h) must be set to 0 when MCLK is selected as the PLL Clock Source.
	0	FLL_TO_PLL3	0	PLL3 Clock Source 0 = Selected by PLL_CLK_SRC 1 = FLL

Register 83h PLL 4

REGISTER ADDRESS	BIT	LABEL	DEFAULT	DESCRIPTION
------------------	-----	-------	---------	-------------

REGISTER ADDRESS	BIT	LABEL	DEFAULT	DESCRIPTION
R136 (88h) PLL 9	6	PLL2_FRAC	1	PLL2 Fractional enable 0 = Integer Mode 1 = Fractional Mode (recommended)
	4:0	PLL2_N [4:0]	0_0111	Integer Multiply for PLL2 (LSB = 1)

Register 88h PLL 9

REGISTER ADDRESS	BIT	LABEL	DEFAULT	DESCRIPTION
R137 (89h) PLL 10	7:0	PLL2_K [7:0]	0001_1100	Fractional Multiply for PLL2 (MSB = 0.5) This is bits 23:16 of a 24-bit field

Register 89h PLL 10

REGISTER ADDRESS	BIT	LABEL	DEFAULT	DESCRIPTION
R138 (8Ah) PLL 11	7:0	PLL2_K [7:0]	0111_0001	Fractional Multiply for PLL2 (MSB = 0.5) This is bits 15:8 of a 24-bit field

Register 8Ah PLL 11

REGISTER ADDRESS	BIT	LABEL	DEFAULT	DESCRIPTION
R139 (8Bh) PLL 12	7:0	PLL2_K [7:0]	1100_0111	Fractional Multiply for PLL2 (MSB = 0.5) This is bits 7:0 of a 24-bit field

Register 8Bh PLL 12

REGISTER ADDRESS	BIT	LABEL	DEFAULT	DESCRIPTION
R140 (8Ch) PLL 13	6	PLL3_FRAC	1	PLL3 Fractional enable 0 = Integer Mode 1 = Fractional Mode (recommended)
	4:0	PLL3_N [4:0]	0_0111	Integer Multiply for PLL3 (LSB = 1)

Register 8Ch PLL 13

REGISTER ADDRESS	BIT	LABEL	DEFAULT	DESCRIPTION
R141 (8Dh) PLL 14	7:0	PLL3_K [7:0]	0100_1000	Fractional Multiply for PLL3 (MSB = 0.5) This is bits 23:16 of a 24-bit field

Register 8Dh PLL 14

REGISTER ADDRESS	BIT	LABEL	DEFAULT	DESCRIPTION
------------------	-----	-------	---------	-------------

REGISTER ADDRESS	BIT	LABEL	DEFAULT	DESCRIPTION
R142 (8Eh) PLL 15	7:0	PLL3_K [7:0]	0010_0010	Fractional Multiply for PLL3 (MSB = 0.5) This is bits 15:8 of a 24-bit field

Register 8Eh PLL 15

REGISTER ADDRESS	BIT	LABEL	DEFAULT	DESCRIPTION
R143 (8Fh) PLL 16	7:0	PLL3_K [7:0]	1001_0111	Fractional Multiply for PLL3 (MSB = 0.5) This is bits 7:0 of a 24-bit field

Register 8Fh PLL 16

REGISTER ADDRESS	BIT	LABEL	DEFAULT	DESCRIPTION
R150 (96h) PLL DLL	1	SEQ_ENA	1	PLL Control Sequencer Enable 0 = Disabled 1 = Enabled This bit must be set to 0 when MCLK is selected as the PLL Clock Source.
	0	Reserved	1	Reserved - do not change

Register 96h PLL DLL

REGISTER ADDRESS	BIT	LABEL	DEFAULT	DESCRIPTION
R152 (98h) Analogue Clocking 4	7		1	Reserved - do not change
	6		1	Reserved - do not change
	4	OSC_MCLK_SRC	0	PLL3 / Oscillator to MCLK source 0 = PLL3 1 = Oscillator This field selects the MCLK source, when MCLK_SRC =10.

Register 98h Analogue Clocking 4

REGISTER ADDRESS	BIT	LABEL	DEFAULT	DESCRIPTION
R155 (9Bh) FLL Control (1)	6:5	FLL_REFCLK_SRC [1:0]	00	FLL Clock Source 00 = MCLK 01 = BCLK 10 = Internal oscillator 11 = Reserved
	3	Reserved	1	Reserved - do not change
	2	FLL_FRAC	1	FLL Fractional Mode enable 0 = Integer Mode 1 = Fractional Mode Fractional Mode (FLL_FRAC=1) is recommended in all cases
	1	FLL_OSC_ENA	0	FLL Oscillator enable 0 = Disabled 1 = Enabled (Note that this field is required for free-running FLL modes)

REGISTER ADDRESS	BIT	LABEL	DEFAULT	DESCRIPTION
				only)
	0	FLL_ENA	0	FLL Enable 0 = Disabled 1 = Enabled

Register 9Bh FLL Control (1)

REGISTER ADDRESS	BIT	LABEL	DEFAULT	DESCRIPTION
R156 (9Ch) FLL Control (2)	8:3	FLL_OUTDIV [5:0]	00_0111	FLL FOUT clock ratio 000000 = Reserved 000001 = 2 000010 = 3 000011 = 4 000100 = 5 000101 = 6 ... 111110 = 63 111111 = 64 (FOUT = FVCO / FLL_OUTDIV)
	1:0	FLL_REFCLK_DIV [1:0]	01	FLL Clock Reference Divider 00 = MCLK / 1 01 = MCLK / 2 10 = MCLK / 4 11 = Reserved MCLK (or other input reference) must be divided down to <=13.5MHz. For lower power operation, the reference clock can be divided down further if desired.

Register 9Ch FLL Control (2)

REGISTER ADDRESS	BIT	LABEL	DEFAULT	DESCRIPTION
R157 (9Dh) FLL Control (3)	8	Reserved	1	Reserved - do not change
	7	Reserved	1	Reserved - do not change
	2:0	FLL_FRATIO [2:0]	000	FLL FVCO clock ratio 000 = 1 001 = 2 010 = 4 011 = 8 1XX = 16 000 recommended for FREF > 1MHz 011 recommended for FREF < 64kHz

Register 9Dh FLL Control (3)

REGISTER ADDRESS	BIT	LABEL	DEFAULT	DESCRIPTION
R159 (9Fh) FLL Control (5)	6:1	FLL_FRC_NCO_VAL [5:0]	01_1001	FLL Forced oscillator value Valid range is 000000 to 111111 0x19h (011001) = 12MHz approx (Note that this field is required for free-running FLL modes

REGISTER ADDRESS	BIT	LABEL	DEFAULT	DESCRIPTION
				only)
	0	FLL_FRC_NCO	0	FLL Forced control select 0 = Normal 1 = FLL oscillator controlled by FLL_FRC_NCO_VAL (Note that this field is required for free-running FLL modes only)

Register 9Fh FLL Control (5)

REGISTER ADDRESS	BIT	LABEL	DEFAULT	DESCRIPTION
R160 (A0h) FLL Control (6)	15:0	FLL_THETA [15:0]	0000_0000 _0001_100 0	FLL Fractional multiply for FREF. Only valid when FLL_FRAC = 1. This field sets the numerator (multiply) part of the FLL_THETA / FLL_LAMBDA ratio. It is coded as LSB = 1.

Register A0h FLL Control (6)

REGISTER ADDRESS	BIT	LABEL	DEFAULT	DESCRIPTION
R161 (A1h) FLL Control (7)	15:0	FLL_LAMBDA [15:0]	0000_0000 _0111_110 1	FLL Fractional multiply for FREF. Only valid when FLL_FRAC = 1. This field sets the denominator (dividing) part of the FLL_THETA / FLL_LAMBDA ratio. It is coded as LSB = 1. Note that it is required that FLL_LAMBDA > 0 in all cases (Integer and Fractional modes).

Register A1h FLL Control (7)

REGISTER ADDRESS	BIT	LABEL	DEFAULT	DESCRIPTION
R162 (A2h) FLL Control (8)	9:0	FLL_N [9:0]	00_0000_1 000	FLL Integer multiply for FREF (LSB = 1)

Register A2h FLL Control (8)

REGISTER ADDRESS	BIT	LABEL	DEFAULT	DESCRIPTION
R252 (FCh) General test 1	2	Reserved	1	Reserved - do not change
	0	AUTO_INC	1	Enables address auto-increment (applies to 2-wire I2C mode only) 0 = Disabled 1 = Enabled

Register FCh General test 1

REGISTER ADDRESS	BIT	LABEL	DEFAULT	DESCRIPTION
R256 (0100h) DF1	2	DF1_SHARED_COEFF	0	DF1 Shared Coefficients Enable 0 = Disabled 1 = Enabled
	1	DF1_SHARED_COEFF_SEL	0	DF1 Shared Coefficients Select 0 = Both channels use left coefficients

REGISTER ADDRESS	BIT	LABEL	DEFAULT	DESCRIPTION
				1 = Both channels use right coefficients
	0	DF1_ENA	0	DF1 Enable in ADC path 0 = Disabled 1 = Enabled

Register 0100h DF1

REGISTER ADDRESS	BIT	LABEL	DEFAULT	DESCRIPTION
R257 (0101h) DF2	15:0	DF1_COEFF_L0 [15:0]	0000_0000 _0000_000 0	DF1 Filter Coefficient Left 0

Register 0101h DF2

REGISTER ADDRESS	BIT	LABEL	DEFAULT	DESCRIPTION
R258 (0102h) DF3	15:0	DF1_COEFF_L1 [15:0]	0000_0000 _0000_000 0	DF1 Filter Coefficient Left 1

Register 0102h DF3

REGISTER ADDRESS	BIT	LABEL	DEFAULT	DESCRIPTION
R259 (0103h) DF4	15:0	DF1_COEFF_L2 [15:0]	0000_0000 _0000_000 0	DF1 Filter Coefficient Left 2

Register 0103h DF4

REGISTER ADDRESS	BIT	LABEL	DEFAULT	DESCRIPTION
R260 (0104h) DF5	15:0	DF1_COEFF_R 0 [15:0]	0000_0000 _0000_000 0	DF1 Filter Coefficient Right 0

Register 0104h DF5

REGISTER ADDRESS	BIT	LABEL	DEFAULT	DESCRIPTION
R261 (0105h) DF6	15:0	DF1_COEFF_R 1 [15:0]	0000_0000 _0000_000 0	DF1 Filter Coefficient Right 1

Register 0105h DF6

REGISTER ADDRESS	BIT	LABEL	DEFAULT	DESCRIPTION
R262 (0106h) DF7	15:0	DF1_COEFF_R 2 [15:0]	0000_0000 _0000_000 0	DF1 Filter Coefficient Right 2

Register 0106h DF7

REGISTER ADDRESS	BIT	LABEL	DEFAULT	DESCRIPTION
R264 (0108h) LHPF1	1	LHPF_MODE	0	Low/High-Pass Filter mode select 0 = Low-Pass 1 = High-Pass
	0	LHPF_ENA	0	Low/High-Pass Filter 0 = Disable 1 = Enable

Register 0108h LHPF1

REGISTER ADDRESS	BIT	LABEL	DEFAULT	DESCRIPTION
R265 (0109h) LHPF2	15:0	LHPF_COEFF [15:0]	0000_0000 _0000_000 0	LHPF Coefficient

Register 0109h LHPF2

REGISTER ADDRESS	BIT	LABEL	DEFAULT	DESCRIPTION
R268 (010Ch) THREED1	6	ADC_MONOMI X	0	ADC Monomix enable 0 = Disabled 1 = Enabled Note that THREED_ENA must be disabled for ADC_MONOMIX to be effective.
	5	THREED_SIGN _L	0	3D Left Cross mixing polarity (from the right channel to the left) 0 = Positive 1 = Negative
	4	THREED_SIGN _R	0	3D Right Cross mixing polarity (from the left channel to the right) 0 = Positive 1 = Negative
	2	THREED_LHPF _MODE	0	3D Low/High-Pass filter mode 0 = Low-Pass 1 = High-Pass
	1	THREED_LHPF _ENA	0	3D Low/High-Pass filter enable 0 = Disabled 1 = Enabled
	0	THREED_ENA	0	3D Surround Sound enable 0 = Disabled 1 = Enabled Note that setting THREED_ENA will cause any ADC_MONOMIX setting to be ignored

Register 010Ch THREED1

REGISTER ADDRESS	BIT	LABEL	DEFAULT	DESCRIPTION
R269 (010Dh) THREED2	15:11	THREED_FGAI NL [4:0]	0_0000	3D Left Forward Gain 00000 = Mute 00001 = -11.25dB 00010 = -10.875dB (...in steps of -0.375dB) 11110 = -0.375dB 11111 = 0.0dB
	10:6	THREED_CGAI NL [4:0]	0_0000	3D Left Cross Gain (from the right channel to the left) 00000 = Mute 00001 = -11.25dB 00010 = -10.875dB (...in steps of -0.375dB) 11110 = -0.375dB 11111 = 0.0dB
	5:2	THREED_DELA YL [3:0]	0000	3D Left Filter Delay (measured from the sample rate) 0000 = 0 samples 0001 = 1 samples 0010 = 2 samples 0011 = 3 samples 0100 = 4 samples 0101 = 5 samples 0110 = 6 samples 0111 = 7 samples 1000 = 8 samples 1001 to 1111 = Reserved

Register 010Dh THREED2

REGISTER ADDRESS	BIT	LABEL	DEFAULT	DESCRIPTION
R270 (010Eh) THREED3	15:0	THREED_LHPF _COEFF [15:0]	0000_0000 _0000_0000 0	3D LHPF coefficient

Register 010Eh THREED3

REGISTER ADDRESS	BIT	LABEL	DEFAULT	DESCRIPTION
R271 (010Fh) THREED4	15:11	THREED_FGAI NR [4:0]	0_0000	3D Right Forward Gain 00000 = Mute 00001 = -11.25dB 00010 = -10.875dB (...in steps of -0.375dB) 11110 = -0.375dB 11111 = 0.0dB
	10:6	THREED_CGAI NR [4:0]	0_0000	3D Right Cross Gain (from the left channel to the right) 00000 = Mute 00001 = -11.25dB 00010 = -10.875dB (...in steps of -0.375dB) 11110 = -0.375dB 11111 = 0.0dB
	5:2	THREED_DELA YR [3:0]	0000	3D Filter Delay (measured from the sample rate) 0000 = 0 samples 0001 = 1 samples 0010 = 2 samples

REGISTER ADDRESS	BIT	LABEL	DEFAULT	DESCRIPTION
				0011 = 3 samples 0100 = 4 samples 0101 = 5 samples 0110 = 6 samples 0111 = 7 samples 1000 = 8 samples 1001 to 1111 = Reserved

Register 010Fh THREED4

REGISTER ADDRESS	BIT	LABEL	DEFAULT	DESCRIPTION
R276 (0114h) DRC 1	14:10	DRC_SIG_DET_RMS [4:0]	0_0000	DRC Signal Detect RMS Threshold. This is the RMS signal level for signal detect to be indicated when DRC_SIG_DET_MODE=1. 00000 = -27dB 00001 = -28.5dB (1.5dB steps) 11110 = -72dB 11111 = -73.5dB
	9:8	DRC_SIG_DET_PK [1:0]	00	DRC Signal Detect Peak Threshold. This is the Peak/RMS ratio, or Crest Factor, level for signal detect to be indicated when DRC_SIG_DET_MODE=0. 00 = 14dB 01 = 20dB 10 = 26dB 11 = 32dB
	7	DRC_NG_ENA	0	DRC Noise Gate Enable 0 = Disabled 1 = Enabled
	6	DRC_SIG_DET_MODE	0	DRC Signal Detect Mode 0 = Peak threshold mode 1 = RMS threshold mode
	5	DRC_SIG_DET	0	DRC Signal Detect Enable 0 = Disabled 1 = Enabled
	4	DRC_KNEE2_OP_ENA	0	DRC_KNEE2_OP Enable 0 = Disabled 1 = Enabled
	3	DRC_QR	1	DRC Quick-release Enable 0 = Disabled 1 = Enabled
	2	DRC_ANTICLIP	1	DRC Anti-clip Enable 0 = Disabled 1 = Enabled
	1	DRC_MODE	0	DRC path select 0 = ADC path 1 = DAC path
	0	DRC_ENA	0	DRC Enable 0 = Disabled 1 = Enabled

Register 0114h DRC 1

REGISTER ADDRESS	BIT	LABEL	DEFAULT	DESCRIPTION
R277 (0115h) DRC 2	12:9	DRC_ATK [3:0]	0100	Gain attack rate (seconds/6dB) 0000 = Reserved 0001 = 181us 0010 = 363us 0011 = 726us 0100 = 1.45ms 0101 = 2.9ms 0110 = 5.8ms 0111 = 11.6ms 1000 = 23.2ms 1001 = 46.4ms 1010 = 92.8ms 1011 = 185.6ms 1100-1111 = Reserved
	8:5	DRC_DCY [3:0]	1001	Gain decay rate (seconds/6dB) 0000 = 1.45ms 0001 = 2.9ms 0010 = 5.8ms 0011 = 11.6ms 0100 = 23.25ms 0101 = 46.5ms 0110 = 93ms 0111 = 186ms 1000 = 372ms 1001 = 743ms (default) 1010 = 1.49s 1011 = 2.97s 1100 = 5.94s 1101 = 11.89s 1110 = 23.78s 1111 = 47.56s
	4:2	DRC_MINGAIN [2:0]	001	Minimum gain the DRC can use to attenuate audio signals 000 = 0dB 001 = -12dB (default) 010 = -18dB 011 = -24dB 100 = -36dB 101to 111 = Reserved
	1:0	DRC_MAXGAIN [1:0]	01	Maximum gain the DRC can use to boost audio signals (dB) 00 = 12dB 01 = 18dB (default) 10 = 24dB 11 = 36dB

Register 0115h DRC 2

REGISTER ADDRESS	BIT	LABEL	DEFAULT	DESCRIPTION
R278 (0116h) DRC 3	15:12	DRC_NG_MINGAIN [3:0]	0000	Minimum gain the DRC can use to attenuate audio signals when the noise gate is active. 0000 = -36dB 0001 = -30dB 0010 = -24dB 0011 = -18dB 0100 = -12dB 0101 = -6dB 0110 = 0dB

REGISTER ADDRESS	BIT	LABEL	DEFAULT	DESCRIPTION
				0111 = 6dB 1000 = 12dB 1001 = 18dB 1010 = 24dB 1011 = 30dB 1100 to 1111 = Reserved
	11:10	DRC_QR_THR [1:0]	00	DRC Quick-release threshold (crest factor in dB) 00 = 12dB 01 = 18dB 10 = 24dB 11 = 30dB
	9:8	DRC_QR_DCY [1:0]	00	DRC Quick-release decay rate (seconds/6dB) 00 = 0.725ms 01 = 1.45ms 10 = 5.8ms 11 = reserved
	7:6	DRC_NG_EXP [1:0]	00	Noise Gate slope 00 = 1 (no expansion) 01 = 2 10 = 4 11 = 8
	5:3	DRC_HI_COMP [2:0]	000	Compressor slope (upper region) 000 = 1 (no compression) 001 = 1/2 010 = 1/4 011 = 1/8 (default) 100 = 1/16 101 = 0 (ALC Mode) 110 = Reserved 111 = Reserved
	2:0	DRC_LO_COMP P [2:0]	000	Compressor slope (lower region) 000 = 1 (no compression) 001 = 1/2 010 = 1/4 011 = 1/8 100 = 0 101 to 111 = Reserved

Register 0116h DRC 3

REGISTER ADDRESS	BIT	LABEL	DEFAULT	DESCRIPTION
R279 (0117h) DRC 4	10:5	DRC_KNEE_IP [5:0]	00_0000	Input signal level at the Compressor 'Knee'. 000000 = 0dB 000001 = -0.75dB 000010 = -1.5dB ... (-0.75dB steps) 111100 = -45dB 111101 to 111111 = Reserved
	4:0	DRC_KNEE_OP [4:0]	0_0000	Output signal at the Compressor 'Knee'. 000000 = 0dB 000001 = -0.75dB 000010 = -1.5dB ... (-0.75dB steps) 111110 = -22.5dB 111111 = Reserved

Register 0117h DRC 4

REGISTER ADDRESS	BIT	LABEL	DEFAULT	DESCRIPTION
R280 (0118h) DRC 5	9:5	DRC_KNEE2_IP [4:0]	0_0000	Input signal level at the Noise Gate threshold 'Knee2'. 000000 = -36dB 000001 = -37.5dB 000010 = -39dB ... (-1.5dB steps) 111110 = -81dB 111111 = -82.5dB Only applicable when DRC_NG_ENA = 1.
	4:0	DRC_KNEE2_OP P [4:0]	0_0000	Output signal at the Noise Gate threshold 'Knee2'. 000000 = -30dB 000001 = -31.5dB 000010 = -33dB ... (-1.5dB steps) 111110 = -75dB 111111 = -76.5dB Only applicable when DRC_KNEE2_OP_ENA = 1.

Register 0118h DRC 5

REGISTER ADDRESS	BIT	LABEL	DEFAULT	DESCRIPTION
R285 (011Dh) Tloopback	1	TLB_ENA	0	T-Loopback Enable 0 = Disabled 1 = Enabled
	0	TLB_MODE	0	T-Loopback Mode Select 0: Left AIF Output = Left ADC; Right AIF Output = (Left DAC + Right DAC) / 2 1: Left AIF Output = (Left DAC + Right DAC) / 2; Right AIF Output = Right ADC

Register 011Dh Tloopback

REGISTER ADDRESS	BIT	LABEL	DEFAULT	DESCRIPTION
R335 (014Fh) EQ1	2	EQ_SHARED_C OEFF	1	5-Band EQ Shared Coefficient enable 0 = Right and Left channels use unique coefficients 1 = Left and right channels share filter coefficients
	1	EQ_SHARED_C OEFF_SEL	0	5-Band EQ Shared Coefficient select 0 = Both channels use the left channel filter coefficients 1 = Both channels use the right channel filter coefficients
	0	EQ_ENA	0	5-Band EQ Enable 0 = Disabled 1 = Enabled

Register 014Fh EQ1

REGISTER ADDRESS	BIT	LABEL	DEFAULT	DESCRIPTION
R336 (0150h) EQ2	15:11	EQL_B1_GAIN [4:0]	0_1100	Left Channel Band 1 EQ Gain 0_0000 = -12dB 0_0001 = -11dB ...1dB steps to 1_1000 = +12dB 1_1001 to 1_1111 reserved
	10:6	EQL_B2_GAIN [4:0]	0_1100	Left Channel Band 2 EQ Gain 0_0000 = -12dB 0_0001 = -11dB ...1dB steps to 1_1000 = +12dB 1_1001 to 1_1111 reserved
	5:1	EQL_B3_GAIN [4:0]	0_1100	Left Channel Band 3 EQ Gain 0_0000 = -12dB 0_0001 = -11dB ...1dB steps to 1_1000 = +12dB 1_1001 to 1_1111 reserved

Register 0150h EQ2

REGISTER ADDRESS	BIT	LABEL	DEFAULT	DESCRIPTION
R337 (0151h) EQ3	15:11	EQL_B4_GAIN [4:0]	0_1100	Left Channel Band 4 EQ Gain 0_0000 = -12dB 0_0001 = -11dB ...1dB steps to 1_1000 = +12dB 1_1001 to 1_1111 reserved
	10:6	EQL_B5_GAIN [4:0]	0_1100	Left Channel Band 5 EQ Gain 0_0000 = -12dB 0_0001 = -11dB ...1dB steps to 1_1000 = +12dB 1_1001 to 1_1111 reserved

Register 0151h EQ3

REGISTER ADDRESS	BIT	LABEL	DEFAULT	DESCRIPTION
R338 (0152h) EQ4	15:0	EQL_B1_A [15:0]	0000_1111 _1100_101 0	5 Band EQ Band 1 coefficient A

Register 0152h EQ4

REGISTER ADDRESS	BIT	LABEL	DEFAULT	DESCRIPTION
R339 (0153h) EQ5	15:0	EQL_B1_B [15:0]	0000_0100 _0000_000 0	5 Band EQ Band 1 coefficient B

Register 0153h EQ5

REGISTER ADDRESS	BIT	LABEL	DEFAULT	DESCRIPTION
R340 (0154h) EQ6	15:0	EQL_B1_PG [15:0]	0000_0000 _1101_100 0	5 Band EQ Band 1 coefficient PG

Register 0154h EQ6

REGISTER ADDRESS	BIT	LABEL	DEFAULT	DESCRIPTION
R341 (0155h) EQ7	15:0	EQL_B2_A [15:0]	0001_1110 _1011_010 1	5 Band EQ Band 2 coefficient A

Register 0155h EQ7

REGISTER ADDRESS	BIT	LABEL	DEFAULT	DESCRIPTION
R342 (0156h) EQ8	15:0	EQL_B2_B [15:0]	1111_0001 _0100_010 1	5 Band EQ Band 2 coefficient B

Register 0156h EQ8

REGISTER ADDRESS	BIT	LABEL	DEFAULT	DESCRIPTION
R343 (0157h) EQ9	15:0	EQL_B2_C [15:0]	0000_1011 _0111_010 1	5 Band EQ Band 2 coefficient C

Register 0157h EQ9

REGISTER ADDRESS	BIT	LABEL	DEFAULT	DESCRIPTION
R344 (0158h) EQ10	15:0	EQL_B2_PG [15:0]	0000_0001 _1100_010 1	5 Band EQ Band 2 coefficient PG

Register 0158h EQ10

REGISTER ADDRESS	BIT	LABEL	DEFAULT	DESCRIPTION
R345 (0159h) EQ11	15:0	EQL_B3_A [15:0]	0001_1100 _0101_100 0	5 Band EQ Band 3 coefficient A

Register 0159h EQ11

REGISTER ADDRESS	BIT	LABEL	DEFAULT	DESCRIPTION
R346 (015Ah) EQ12	15:0	EQL_B3_B [15:0]	1111_0011 _0111_001 1	5 Band EQ Band 3 coefficient B

Register 015Ah EQ12

REGISTER ADDRESS	BIT	LABEL	DEFAULT	DESCRIPTION
R347 (015Bh) EQ13	15:0	EQL_B3_C [15:0]	0000_1010 _0101_010 0	5 Band EQ Band 3 coefficient C

Register 015Bh EQ13

REGISTER ADDRESS	BIT	LABEL	DEFAULT	DESCRIPTION
R348 (015Ch) EQ14	15:0	EQL_B3_PG [15:0]	0000_0101 _0101_100 0	5 Band EQ Band 3 coefficient PG

Register 015Ch EQ14

REGISTER ADDRESS	BIT	LABEL	DEFAULT	DESCRIPTION
R349 (015Dh) EQ15	15:0	EQL_B4_A [15:0]	0001_0110 _1000_111 0	5 Band EQ Band 4 coefficient A

Register 015Dh EQ15

REGISTER ADDRESS	BIT	LABEL	DEFAULT	DESCRIPTION
R350 (015Eh) EQ16	15:0	EQL_B4_B [15:0]	1111_1000 _0010_100 1	5 Band EQ Band 4 coefficient B

Register 015Eh EQ16

REGISTER ADDRESS	BIT	LABEL	DEFAULT	DESCRIPTION
R351 (015Fh) EQ17	15:0	EQL_B4_C [15:0]	0000_0111 _1010_110 1	5 Band EQ Band 4 coefficient C

Register 015Fh EQ17

REGISTER ADDRESS	BIT	LABEL	DEFAULT	DESCRIPTION
R352 (0160h) EQ18	15:0	EQL_B4_PG [15:0]	0001_0001 _0000_001 1	5 Band EQ Band 2 coefficient PG

Register 0160h EQ18

REGISTER ADDRESS	BIT	LABEL	DEFAULT	DESCRIPTION
R353 (0161h) EQ19	15:0	EQL_B5_A [15:0]	0000_0101 _0110_010 0	5 Band EQ Band 5 coefficient A

Register 0161h EQ19

REGISTER ADDRESS	BIT	LABEL	DEFAULT	DESCRIPTION
R354 (0162h) EQ20	15:0	EQL_B5_B [15:0]	0000_0101 _0101_100 1	5 Band EQ Band 5 coefficient B

Register 0162h EQ20

REGISTER ADDRESS	BIT	LABEL	DEFAULT	DESCRIPTION
R355 (0163h) EQ21	15:0	EQL_B5_PG [15:0]	0100_0000 _0000_000 0	5 Band EQ Band 5 coefficient PG

Register 0163h EQ21

REGISTER ADDRESS	BIT	LABEL	DEFAULT	DESCRIPTION
R356 (0164h) EQ22	15:11	EQR_B1_GAIN [4:0]	0_1100	Right Channel Band 1 EQ Gain 0_0000 = -12dB 0_0001 = -11dB ...1dB steps to 1_1000 = +12dB 1_1001 to 1_1111 reserved
	10:6	EQR_B2_GAIN [4:0]	0_1100	Right Channel Band 2 EQ Gain 0_0000 = -12dB 0_0001 = -11dB ...1dB steps to 1_1000 = +12dB 1_1001 to 1_1111 reserved
	5:1	EQR_B3_GAIN [4:0]	0_1100	Right Channel Band 3 EQ Gain 0_0000 = -12dB 0_0001 = -11dB ...1dB steps to 1_1000 = +12dB 1_1001 to 1_1111 reserved

Register 0164h EQ22

REGISTER ADDRESS	BIT	LABEL	DEFAULT	DESCRIPTION
R357 (0165h) EQ23	15:11	EQR_B4_GAIN [4:0]	0_1100	Right Channel Band 4 EQ Gain 0_0000 = -12dB 0_0001 = -11dB ...1dB steps to 1_1000 = +12dB 1_1001 to 1_1111 reserved
	10:6	EQR_B5_GAIN [4:0]	0_1100	Right Channel Band 5 EQ Gain 0_0000 = -12dB 0_0001 = -11dB ...1dB steps to 1_1000 = +12dB 1_1001 to 1_1111 reserved

Register 0165h EQ23

REGISTER ADDRESS	BIT	LABEL	DEFAULT	DESCRIPTION
R358 (0166h) EQ24	15:0	EQR_B1_A [15:0]	0000_1111 _1100_101 0	5 Band EQ Band 1 coefficient A

Register 0166h EQ24

REGISTER ADDRESS	BIT	LABEL	DEFAULT	DESCRIPTION
R359 (0167h) EQ25	15:0	EQR_B1_B [15:0]	0000_0100 _0000_000 0	5 Band EQ Band 1 coefficient B

Register 0167h EQ25

REGISTER ADDRESS	BIT	LABEL	DEFAULT	DESCRIPTION
R360 (0168h) EQ26	15:0	EQR_B1_PG [15:0]	0000_0000 _1101_100 0	5 Band EQ Band 1 coefficient PG

Register 0168h EQ26

REGISTER ADDRESS	BIT	LABEL	DEFAULT	DESCRIPTION
R361 (0169h) EQ27	15:0	EQR_B2_A [15:0]	0001_1110 _1011_010 1	5 Band EQ Band 2 coefficient A

Register 0169h EQ27

REGISTER ADDRESS	BIT	LABEL	DEFAULT	DESCRIPTION
R362 (016Ah) EQ28	15:0	EQR_B2_B [15:0]	1111_0001 _0100_010 1	5 Band EQ Band 2 coefficient B

Register 016Ah EQ28

REGISTER ADDRESS	BIT	LABEL	DEFAULT	DESCRIPTION
R363 (016Bh) EQ29	15:0	EQR_B2_C [15:0]	0000_1011 _0111_010 1	5 Band EQ Band 2 coefficient C

Register 016Bh EQ29

REGISTER ADDRESS	BIT	LABEL	DEFAULT	DESCRIPTION
R364 (016Ch) EQ30	15:0	EQR_B2_PG [15:0]	0000_0001 _1100_010 1	5 Band EQ Band 2 coefficient PG

Register 016Ch EQ30

REGISTER ADDRESS	BIT	LABEL	DEFAULT	DESCRIPTION
R365 (016Dh) EQ31	15:0	EQR_B3_A [15:0]	0001_1100 _0101_100 0	5 Band EQ Band 3 coefficient A

Register 016Dh EQ31

REGISTER ADDRESS	BIT	LABEL	DEFAULT	DESCRIPTION
R366 (016Eh) EQ32	15:0	EQR_B3_B [15:0]	1111_0011 _0111_001 1	5 Band EQ Band 3 coefficient B

Register 016Eh EQ32

REGISTER ADDRESS	BIT	LABEL	DEFAULT	DESCRIPTION
R367 (016Fh) EQ33	15:0	EQR_B3_C [15:0]	0000_1010 _0101_010 0	5 Band EQ Band 3 coefficient C

Register 016Fh EQ33

REGISTER ADDRESS	BIT	LABEL	DEFAULT	DESCRIPTION
R368 (0170h) EQ34	15:0	EQR_B3_PG [15:0]	0000_0101 _0101_100 0	5 Band EQ Band 3 coefficient PG

Register 0170h EQ34

REGISTER ADDRESS	BIT	LABEL	DEFAULT	DESCRIPTION
R369 (0171h) EQ35	15:0	EQR_B4_A [15:0]	0001_0110 _1000_111 0	5 Band EQ Band 4 coefficient A

Register 0171h EQ35

REGISTER ADDRESS	BIT	LABEL	DEFAULT	DESCRIPTION
R370 (0172h) EQ36	15:0	EQR_B4_B [15:0]	1111_1000 _0010_100 1	5 Band EQ Band 4 coefficient B

Register 0172h EQ36

REGISTER ADDRESS	BIT	LABEL	DEFAULT	DESCRIPTION
R371 (0173h) EQ37	15:0	EQR_B4_C [15:0]	0000_0111 _1010_110 1	5 Band EQ Band 4 coefficient C

Register 0173h EQ37

REGISTER ADDRESS	BIT	LABEL	DEFAULT	DESCRIPTION
R372 (0174h) EQ38	15:0	EQR_B4_PG [15:0]	0001_0001 _0000_001 1	5 Band EQ Band 2 coefficient PG

Register 0174h EQ38

REGISTER ADDRESS	BIT	LABEL	DEFAULT	DESCRIPTION
R373 (0175h) EQ39	15:0	EQR_B5_A [15:0]	0000_0101 _0110_010 0	5 Band EQ Band 5 coefficient A

Register 0175h EQ39

REGISTER ADDRESS	BIT	LABEL	DEFAULT	DESCRIPTION
R374 (0176h) EQ40	15:0	EQR_B5_B [15:0]	0000_0101 _0101_100 1	5 Band EQ Band 5 coefficient B

Register 0176h EQ40

REGISTER ADDRESS	BIT	LABEL	DEFAULT	DESCRIPTION
R375 (0177h) EQ41	15:0	EQR_B5_PG [15:0]	0100_0000 _0000_000 0	5 Band EQ Band 5 coefficient PG

Register 0177h EQ41

REGISTER ADDRESS	BIT	LABEL	DEFAULT	DESCRIPTION
R513 (0201h) GPIO 2	10	GP2_POL	0	GPIO 2 Polarity 0 = Not inverted 1 = Inverted
	6	GP2_LVL	0	GPIO 2 Output Level (when GP2_FN = 00001) 0 = Logic 0 1 = Logic 1

REGISTER ADDRESS	BIT	LABEL	DEFAULT	DESCRIPTION
				Note that this is a Write-Only register; the Readback value is undefined.
	4:0	GP2_FN [4:0]	0_0000	GPIO 2 Pin Function select 0_0000 = CLKOUT (PLL2 / Oscillator) - see note below 0_0001 = Logic 0 or Logic 1 (depending on GP2_LVL) 0_0010 = SDOUT 0_0011 = IRQ 0_0100 = Temperature shutdown 0_0101 = Reserved 0_0110 = PLL2 Lock 0_0111 = PLL3 Lock 0_1000 = Reserved 0_1001 = FLL Lock 0_1010 = DRC Activity detect 0_1011 = Write Sequencer done 0_1100 = ALC Noise Gate active 0_1101 = ALC Peak Limiter overload 0_1110 = ALC Saturation 0_1111 = ALC level threshold 1_0000 = ALC Level lock 1_0001 = FIFO error indicator 1_0010 = OPCLK 1_0011 = Digital Microphone Output Clock 1_0100 = Reserved 1_0101 = Mic Detect flag 1_0110 = Mic Short Circuit flag 1_0111 to 1_1111 = Reserved Note that PLL2 or the internal oscillator CLKOUT is enabled using CLKOUT2_SEL. Setting GP2_FN = 00h is recommended in this case.

Register 0201h GPIO 2

REGISTER ADDRESS	BIT	LABEL	DEFAULT	DESCRIPTION
R514 (0202h) GPIO 3	10	GP3_POL	0	GPIO 3 Polarity 0 = Not inverted 1 = Inverted
	6	GP3_LVL	0	GPIO 3 Output Level (when GP3_FN = 00001) 0 = Logic 0 1 = Logic 1 Note that this is a Write-Only register; the Readback value is undefined.
	4:0	GP3_FN [4:0]	0_0000	GPIO 3 Pin Function select 0_0000 = CLKOUT (PLL3 / FLL) - see note below 0_0001 = Logic 0 or Logic 1 (depending on GP3_LVL) 0_0010 = SDOUT 0_0011 = IRQ 0_0100 = Temperature shutdown 0_0101 = Reserved 0_0110 = PLL2 Lock 0_0111 = PLL3 Lock 0_1000 = Reserved 0_1001 = FLL Lock 0_1010 = DRC Activity detect 0_1011 = Write Sequencer done 0_1100 = ALC Noise Gate active

REGISTER ADDRESS	BIT	LABEL	DEFAULT	DESCRIPTION
				0_1101 = ALC Peak Limiter overload 0_1110 = ALC Saturation 0_1111 = ALC level threshold 1_0000 = ALC Level lock 1_0001 = FIFO error indicator 1_0010 = OPCLK 1_0011 = Digital Microphone Output Clock 1_0100 = Reserved 1_0101 = Mic Detect flag 1_0110 = Mic Short Circuit flag 1_0111 to 1_1111 = Reserved Note that PLL3 or FLL CLKOUT is enabled using CLKOUT3_SEL. Setting GP3_FN = 00h is recommended in this case.

Register 0202h GPIO 3

REGISTER ADDRESS	BIT	LABEL	DEFAULT	DESCRIPTION
R516 (0204h) GPIO 5	15	GP5_DIR	1	GPIO5 Direction 0 = Output 1 = Input
	14	GP5_PU	0	GPIO5 pull-up resistor enable 0 = pull-up disabled 1 = pull-up enabled
	13	GP5_PD	0	GPIO5 pull-down resistor enable 0 = pull-up disabled 1 = pull-down enabled
	10	GP5_POL	0	GPIO5 Polarity 0 = Not inverted 1 = Inverted
	9	GP5_OP_CFG	0	GPIO5 Output pin configuration 0 = CMOS 1 = Open-drain
	8	GP5_DB	1	GPIO5 input de-bounce 0 = Disabled 1 = Enabled
	6	GP5_LVL	0	GPIO 5 Level (when GP5_FN = 00001) 0 = Logic 0 1 = Logic 1 Write to this bit to set the GPIO5 output. Read from this bit to read GPIO input level. Note that, when GPIO5 is configured as an output (GP5_DIR=0), this is a Write-Only register; the Readback value is undefined.
	4:0	GP5_FN [4:0]	0_0000	GPIO5 Pin Function select 0_0000 = Unused 0_0001 = Logic 0 or Logic 1 (depending on GP5_LVL) 0_0010 = SDOUT 0_0011 = IRQ 0_0100 = Temperature shutdown 0_0101 = Reserved 0_0110 = PLL2 Lock 0_0111 = PLL3 Lock 0_1000 = Reserved 0_1001 = FLL Lock

REGISTER ADDRESS	BIT	LABEL	DEFAULT	DESCRIPTION
				0_1010 = DRC Activity detect 0_1011 = Write Sequencer done 0_1100 = ALC Noise Gate active 0_1101 = ALC Peak Limiter overload 0_1110 = ALC Saturation 0_1111 = ALC level threshold 1_0000 = ALC Level lock 1_0001 = FIFO error indicator 1_0010 = OPCLK 1_0011 = Digital Microphone Output Clock 1_0100 = Digital Microphone Input Data 1_0101 = Mic Detect flag 1_0110 = Mic Short Circuit flag 1_0111 to 1_1111 = Reserved Note that GPIO5 functions are only supported when CLKREG_OVD=1. When CLKREG_OVD=0, the contents of Register R516 must not be changed from the default value.

Register 0204h GPIO 5

REGISTER ADDRESS	BIT	LABEL	DEFAULT	DESCRIPTION
R517 (0205h) GPIO 6	15	GP6_DIR	1	GPIO6 Direction 0 = Output 1 = Input
	14	GP6_PU	0	GPIO6 pull-up resistor enable 0 = pull-up disabled 1 = pull-up enabled
	13	GP6_PD	0	GPIO6 pull-down resistor enable 0 = pull-up disabled 1 = pull-down enabled
	10	GP6_POL	0	GPIO6 Polarity 0 = Not inverted 1 = Inverted
	9	GP6_OP_CFG	0	GPIO6 Output pin configuration 0 = CMOS 1 = Open-drain
	8	GP6_DB	1	GPIO6 input de-bounce 0 = Disabled 1 = Enabled
	6	GP6_LVL	0	GPIO 6 Level (when GP6_FN = 00001) 0 = Logic 0 1 = Logic 1 Write to this bit to set the GPIO6 output. Read from this bit to read GPIO input level. Note that, when GPIO6 is configured as an output (GP6_DIR=0), this is a Write-Only register; the Readback value is undefined.
	4:0	GP6_FN [4:0]	0_0000	GPIO6 Pin Function select 0_0000 = CSB Input 0_0001 = Logic 0 or Logic 1 (depending on GP6_LVL) 0_0010 = Reserved 0_0011 = IRQ 0_0100 = Temperature shutdown 0_0101 = Reserved 0_0110 = PLL2 Lock

REGISTER ADDRESS	BIT	LABEL	DEFAULT	DESCRIPTION
				0_0111 = PLL3 Lock 0_1000 = Reserved 0_1001 = FLL Lock 0_1010 = DRC Activity detect 0_1011 = Write Sequencer done 0_1100 = ALC Noise Gate active 0_1101 = ALC Peak Limiter overload 0_1110 = ALC Saturation 0_1111 = ALC level threshold 1_0000 = ALC Level lock 1_0001 = FIFO error indicator 1_0010 = OPCLK 1_0011 = Digital Microphone Output Clock 1_0100 = Digital Microphone Input Data 1_0101 = Mic Detect flag 1_0110 = Mic Short Circuit flag 1_0111 to 1_1111 = Reserved

Register 0205h GPIO 6

REGISTER ADDRESS	BIT	LABEL	DEFAULT	DESCRIPTION
R560 (0230h) Interrupt Status 1	5	GP6_EINT	0	GPIO6 IRQ status 0 = GPIO6 IRQ not set 1 = GPIO6 IRQ set Note: cleared when a '1' is written
	4	GP5_EINT	0	GPIO5 IRQ status 0 = GPIO5 IRQ not set 1 = GPIO5 IRQ set Note: cleared when a '1' is written

Register 0230h Interrupt Status 1

REGISTER ADDRESS	BIT	LABEL	DEFAULT	DESCRIPTION
R561 (0231h) Interrupt Status 2	15	MICSCD_EINT	0	Mic Short Circuit Interrupt Status 0 = MICSCD IRQ not set 1 = MICSCD IRQ set Note: cleared when a '1' is written
	14	MICD_EINT	0	Mic Detect Interrupt Status 0 = MICD IRQ not set 1 = MICD IRQ set Note: cleared when a '1' is written
	13	FIFOS_ERR_EINT	0	FIFO error IRQ status 0 = FIFO error IRQ not set 1 = FIFO error IRQ set Note: cleared when a '1' is written
	12	ALC_LOCK_EINT	0	ALC level lock IRQ status 0 = ALC level lock IRQ not set 1 = ALC level lock IRQ set Note: cleared when a '1' is written
	11	ALC_THRESH_EINT	0	ALC level threshold IRQ status 0 = ALC level threshold IRQ not set 1 = ALC level threshold IRQ set Note: cleared when a '1' is written

REGISTER ADDRESS	BIT	LABEL	DEFAULT	DESCRIPTION
	10	ALC_SAT_EINT	0	ALC saturation IRQ status 0 = ALC saturation IRQ not set 1 = ALC saturation IRQ set Note: cleared when a '1' is written
	9	ALC_PKOVR_EINT	0	ALC peak overload detector IRQ status 0 = ALC pk. overload det. IRQ not set 1 = ALC pk. Overload det. IRQ set Note: cleared when a '1' is written
	8	ALC_NGATE_EINT	0	ALC Noise Gate active IRQ status 0 = ALC Noise Gate IRQ not set 1 = ALC Noise Gate IRQ set Note: cleared when a '1' is written
	7	WSEQ_DONE_EINT	0	Write Sequencer done IRQ status 0 = Write Sequencer IRQ not set 1 = Write Sequencer IRQ set Note: cleared when a '1' is written
	6	DRC_ACTDET_EINT	0	DRC Activity IRQ status 0 = DRC Activity IRQ not set 1 = DRC Activity IRQ set Note: cleared when a '1' is written
	5	FLL_LOCK_EINT	0	FLL lock IRQ status 0 = FLL lock IRQ not set 1 = FLL lock IRQ set Note: cleared when a '1' is written
	3	PLL3_LOCK_EINT	0	PLL3 Lock IRQ status 0 = PLL3 Lock IRQ not set 1 = PLL3 Lock IRQ set Note: cleared when a '1' is written
	2	PLL2_LOCK_EINT	0	PLL2 Lock IRQ status 0 = PLL2 Lock IRQ not set 1 = PLL2 Lock IRQ set Note: cleared when a '1' is written
	0	TEMP_SHUT_EINT	0	Temperature Shutdown IRQ status 0 = Temperature Shutdown IRQ not set 1 = Temperature Shutdown IRQ set Note: cleared when a '1' is written

Register 0231h Interrupt Status 2

REGISTER ADDRESS	BIT	LABEL	DEFAULT	DESCRIPTION
R568 (0238h) Interrupt Status 1 Mask	5	IM_GP6_EINT	1	Interrupt mask for GPIO6 0 = Not masked 1 = Masked
	4	IM_GP5_EINT	1	Interrupt mask for GPIO5 0 = Not masked 1 = Masked

Register 0238h Interrupt Status 1 Mask

REGISTER ADDRESS	BIT	LABEL	DEFAULT	DESCRIPTION
R569 (0239h) Interrupt Status 2 Mask	15	IM_MICSCD_EINT	1	Interrupt mask for Mic Short Circuit 0 = Not masked 1 = Masked
	14	IM_MICD_EINT	1	Interrupt mask for Mic Detect 0 = Not masked 1 = Masked
	13	IM_FIFOS_ERR_EINT	1	Interrupt mask for FIFOS Error 0 = Not masked 1 = Masked
	12	IM_ALC_LOCK_EINT	1	Interrupt mask for ALC Lock 0 = Not masked 1 = Masked
	11	IM_ALC_THRESHOLD_EINT	1	Interrupt mask for ALC Threshold 0 = Not masked 1 = Masked
	10	IM_ALC_SAT_EINT	1	Interrupt mask for ALC Saturation 0 = Not masked 1 = Masked
	9	IM_ALC_PKOVER_EINT	1	Interrupt mask for ALC Peak Detector overload 0 = Not masked 1 = Masked
	8	IM_ALC_NOISE_GATE_ACTIVE_EINT	1	Interrupt mask for ALC Noise Gate active 0 = Not masked 1 = Masked
	7	IM_WRITE_SEQUENCER_DONE_EINT	1	Interrupt mask for Write Sequencer done 0 = Not masked 1 = Masked
	6	IM_DRC_ACTIVITY_DETECT_EINT	1	Interrupt mask for DRC Activity detect 0 = Not masked 1 = Masked
	5	IM_FLL_LOCK_EINT	1	Interrupt mask for FLL Lock 0 = Not masked 1 = Masked
	4	Reserved	1	Reserved - do not change
	3	IM_PLL3_LOCK_EINT	1	Interrupt mask for PLL3 Lock 0 = Not masked 1 = Masked
	2	IM_PLL2_LOCK_EINT	1	Interrupt mask for PLL2 Lock 0 = Not masked 1 = Masked
	1	Reserved	1	Reserved - do not change
0	IM_TEMP_SHUTDOWN_EINT	1	Interrupt mask for Temperature Shutdown 0 = Not masked 1 = Masked	

Register 0239h Interrupt Status 2 Mask

REGISTER ADDRESS	BIT	LABEL	DEFAULT	DESCRIPTION
R576 (0240h) Interrupt Control	0	IRQ_POL	0	Interrupt Output polarity 0 = Active high 1 = Active low

Register 0240h Interrupt Control

REGISTER ADDRESS	BIT	LABEL	DEFAULT	DESCRIPTION
R584 (0248h) IRQ Debounce	5	FLL_LOCK_DB	1	Debounce Enable on FLL Lock 0 = Disabled 1 = Enabled
	4	Reserved	1	Reserved - do not change
	3	PLL3_LOCK_D B	1	Debounce Enable on PLL3 Lock 0 = Disabled 1 = Enabled
	2	PLL2_LOCK_D B	1	Debounce Enable on PLL2 Lock 0 = Disabled 1 = Enabled
	1	Reserved	1	Reserved - do not change
	0	TEMP_SHUT_D B	1	Debounce Enable on Temperature Shutdown 0 = Disabled 1 = Enabled

Register 0248h IRQ Debounce

REGISTER ADDRESS	BIT	LABEL	DEFAULT	DESCRIPTION
R586 (024Ah) MICINT Source Pol	15	MICSCD_IRQ_P OL	0	Mic Short Circuit Interrupt Polarity 0 = Active high (IRQ asserted when MICSHORT_THR is exceeded) 1 = Active low (IRQ asserted when MICSHORT_THR not exceeded)
	14	MICD_IRQ_POL	0	Mic Detect Interrupt Polarity 0 = Active high (IRQ asserted when MICDET_THR is exceeded) 1 = Active low (IRQ asserted when MICDET_THR not exceeded)

Register 024Ah MICINT Source Pol

REGISTER ADDRESS	BIT	LABEL	DEFAULT	DESCRIPTION
R768 (0300h) DSP2 Power Management	0	DSP2_ENA	0	DSP2 Audio Processor Enable. 0 = Disabled 1 = Enabled This bit must be set before any of ADC ReTune, DAC ReTune, DAC HPF, VSS or HDBass is enabled. It must remain set whenever any of these functions is enabled.

Register 0300h DSP2 Power Management

REGISTER ADDRESS	BIT	LABEL	DEFAULT	DESCRIPTION
R1037 (040Dh) DSP2_ExecControl	5	DSP2_STOPC	0	[No description available]
	4	DSP2_STOPS	0	[No description available]
	3	DSP2_STOPI	0	[No description available]
	2	DSP2_STOP	0	Stop the DSP2 audio processor. Writing a 1 to this bit will cause the DSP2 processor to stop processing audio data.
	1	DSP2_RUNR	0	Start the DSP2 audio processor Writing a 1 to this bit will cause the DSP2 processor to start processing audio data
	0	DSP2_RUN	0	[No description available]

Register 040Dh DSP2_ExecControl

REGISTER ADDRESS	BIT	LABEL	DEFAULT	DESCRIPTION
R4096 (1000h) Write Sequencer 0	13:0	WSEQ_ADDR0 [13:0]	00_0000_0 001_1100	Control Register Address to be written to in this sequence step.

Register 1000h Write Sequencer 0

REGISTER ADDRESS	BIT	LABEL	DEFAULT	DESCRIPTION
R4097 (1001h) Write Sequencer 1	7:0	WSEQ_DATA0 [7:0]	0000_0011	Data to be written in this sequence step. When the data width is less than 8 bits, then one or more of the MSBs of WSEQ_DATA0 are ignored. It is recommended that unused bits be set to 0.

Register 1001h Write Sequencer 1

REGISTER ADDRESS	BIT	LABEL	DEFAULT	DESCRIPTION
R4098 (1002h) Write Sequencer 2	10:8	WSEQ_DATA_WIDTH0 [2:0]	001	Width of the data block written in this sequence step. 000 = 1 bit 001 = 2 bits 010 = 3 bits 011 = 4 bits 100 = 5 bits 101 = 6 bits 110 = 7 bits 111 = 8 bits
	3:0	WSEQ_DATA_S TART0 [3:0]	0011	Bit position of the LSB of the data block written in this sequence step. 0000 = Bit 0 ... 1111 = Bit 15

Register 1002h Write Sequencer 2

REGISTER ADDRESS	BIT	LABEL	DEFAULT	DESCRIPTION
R4099 (1003h) Write Sequencer 3	8	WSEQ_EOS0	0	End of Sequence flag. This bit indicates whether the Control Write Sequencer should stop after executing this step. 0 = Not end of sequence 1 = End of sequence (Stop the sequencer after this step).
	3:0	WSEQ_DELAY0 [3:0]	0000	Time delay after executing this step. Total time per step (including execution) = $k \times (2^{\text{WSEQ_DELAY}} + 8)$ $k = 62.5\mu\text{s}$ (SAMPLE_RATE_INT_MODE = 1) $k = 68.1\mu\text{s}$ (SAMPLE_RATE_INT_MODE = 0)

Register 1003h Write Sequencer 3

REGISTER ADDRESS	BIT	LABEL	DEFAULT	DESCRIPTION
R4100 (1004h) Write Sequencer 4 To R4607 (11FFh) Write Sequencer 511				[Write Sequencer Control Registers]

Register 1004h Write Sequencer 4 to **Register 11FFh** Write Sequencer 511

REGISTER ADDRESS	BIT	LABEL	DEFAULT	DESCRIPTION
R16384 (4000h) RETUNEADC_SHARED_COEFF_1	7	ADC_RETUNE_SCV	0	ADC ReTune Coefficient sharing 0 = Left and Right channels each use unique coefficients 1 = Both channels use the Right Channel coefficients
	6:0			[ADC ReTune Control Registers]

Register 4000h RETUNEADC_SHARED_COEFF_1

REGISTER ADDRESS	BIT	LABEL	DEFAULT	DESCRIPTION
R16385 (4001h) RETUNEADC_SHARED_COEFF_0	15:0			[ADC ReTune Control Registers]

Register 4001h RETUNEADC_SHARED_COEFF_0

REGISTER ADDRESS	BIT	LABEL	DEFAULT	DESCRIPTION
R16386 (4002h) RETUNEDA C_SHARED_ COEFF_1	7	DAC_RETUNE_ SCV	0	DAC ReTune Coefficient sharing 0 = Left and Right channels each use unique coefficients 1 = Both channels use the Right Channel coefficients
	6:0			[DAC ReTune Control Registers]

Register 4002h RETUNEDAC_SHARED_COEFF_1

REGISTER ADDRESS	BIT	LABEL	DEFAULT	DESCRIPTION
R16387 (4003h) RETUNEDA C_SHARED_ COEFF_0	15:0			[DAC ReTune Control Registers]

Register 4003h RETUNEDAC_SHARED_COEFF_0

REGISTER ADDRESS	BIT	LABEL	DEFAULT	DESCRIPTION
R16388 (4004h) SOUNDSTA GE_ENABLE S_1	7:0	SOUNDSTAGE _ENABLES_23_ 16 [7:0]	0000_0000	[No description available]

Register 4004h SOUNDSTAGE_ENABLES_1

REGISTER ADDRESS	BIT	LABEL	DEFAULT	DESCRIPTION
R16389 (4005h) SOUNDSTA GE_ENABLE S_0	15:6	SOUNDSTAGE _ENABLES_15_ 06 [9:0]	00_0000_0 000	[No description available]
	5	RTN_ADC_ENA	0	ADC ReTune enable 0 = Disabled 1 = Enabled
	4	RTN_DAC_ENA	0	DAC ReTune enable 0 = Disabled 1 = Enabled
	3	HDBASS_ENA	0	HD Bass enable 0 = HD Bass disabled 1 = HD Bass enabled
	2	HPF2_ENA	0	High-Pass Filter (HPF2) enable 0 = Disabled 1 = Enabled
	1	HPF1_ENA	0	High-Pass Filter (HPF1) enable 0 = Disabled 1 = Enabled
	0	VSS_ENA	0	Virtual Surround Sound (VSS) enable 0 = Disabled 1 = Enabled

Register 4005h SOUNDSTAGE_ENABLES_0

REGISTER ADDRESS	BIT	LABEL	DEFAULT	DESCRIPTION
R16896 (4200h) HDBASS_AI_0 To R16925 (421Dh) HDBASS_PG_0				[HD Bass Control Registers]

Register 4201h HDBASS_AI_0 to Register 421Dh HDBASS_PG_0

REGISTER ADDRESS	BIT	LABEL	DEFAULT	DESCRIPTION
R17408 (4400h) HPF_C_1 To R17409 (4401h) HPF_C_0				[DAC High Pass Filter Control Registers]

Register 4400h HPF_C_1 to Register 4401h HPF_C_0

REGISTER ADDRESS	BIT	LABEL	DEFAULT	DESCRIPTION
R17920 (4600h) ADCL_RETUNE_C1_1 To R19007 (4A3Fh) ADCR_RETUNE_C32_0				[ADC ReTune Control Registers]

Register 4600h ADCL_RETUNE_C1_1 to Register 4A3Fh ADCR_RETUNE_C32_0

REGISTER ADDRESS	BIT	LABEL	DEFAULT	DESCRIPTION
R19456 (4C00h) DACL_RETU NE_C1_1 To R20543 (503Fh) DACR_RETU NE_C32_0				[DAC ReTune Control Registers]

Register 4C00h DACL_RETUNE_C1_1 to Register 503Fh DACR_RETUNE_C32_0

REGISTER ADDRESS	BIT	LABEL	DEFAULT	DESCRIPTION
R20992 (5200h) VSS_XHD2_ 1 To R21139 (5293h) VSS_XTS32 _0				[VSS Control Registers]

Register 5200h VSS_XHD2_1 to Register 5293h VSS_XTS32_0

DIGITAL FILTER CHARACTERISTICS

PARAMETER	TEST CONDITIONS	MIN	TYP	MAX	UNIT
ADC Filter					
Passband				0.454 fs	
	-3dB		0.5 fs		
Passband Ripple	$f < 0.454 \text{ fs}$			+/- 0.05	dB
Stopband		0.546 fs			
Stopband Attenuation	$f > 0.546 \text{ fs}$	-60			dB
DAC Normal Filter					
Passband				0.454 fs	
	-6dB		0.5 fs		
Passband Ripple	$f < 0.454 \text{ fs}$			+/- 0.05	dB
Stopband		0.546 fs			
Stopband Attenuation	$0.546 \text{ fs} < f < 30 \text{ fs}$	-50			dB
DAC Sloping Stopband Filter					
Passband				0.454 fs	
	-9dB		0.5 fs		
Passband Ripple	$f < 0.25 \text{ fs}$			+/- 0.05	dB
	$0.25 \text{ fs} < f < 0.454 \text{ fs}$			+/- 1	
Stopband 1		0.546 fs		0.7 fs	
Stopband 1 Attenuation	$f > 0.546 \text{ fs}$	-60			dB
Stopband 2		0.7 fs		1.4 fs	
Stopband 2 Attenuation	$f > 0.7 \text{ fs}$	-85			dB
Stopband 3		1.4 fs			
Stopband 3 Attenuation	$1.4 \text{ fs} < f < 30 \text{ fs}$	-53			dB

DAC FILTERS		ADC FILTERS	
Mode	Group Delay	Mode	Group Delay
Normal	16.5 / fs	Normal	15 / fs
Sloping Stopband	18 / fs		

TERMINOLOGY

1. Stop Band Attenuation (dB) – the degree to which the frequency spectrum is attenuated (outside audio band)
2. Pass-band Ripple – any variation of the frequency response in the pass-band region

DAC FILTER RESPONSES

This series of plots shows the filter response for the entire DAC channel for different signal rates. The full path, has a nominal gain of 3.01dB (1V input, 1.414V output), this means that the highest nodes in the 48kHz case are at 47.5dB (rather than below the 50dB specification).

Sample Rate (kHz)	Sloping Stop-band	MCLK recommended rate for DAC only playback (CODEC mode) (Hz)
8	Yes	3072000 (3072000)
11.025	Yes	2822400 (2822400)
12	Yes	3072000 (3072000)
16	Yes	2048000 (6144000)
22.05	Yes	2822400 (5644800)
24	Yes	3072000 (6144000)
32	No	2048000 (8192000)
44.1	No	2822400 (11289600)
48	No	3072000 (12288000)

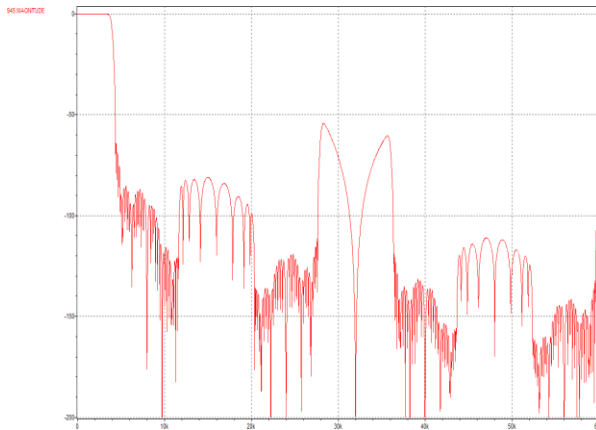
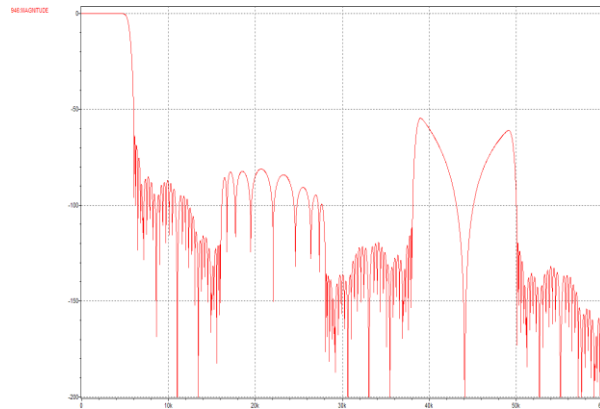
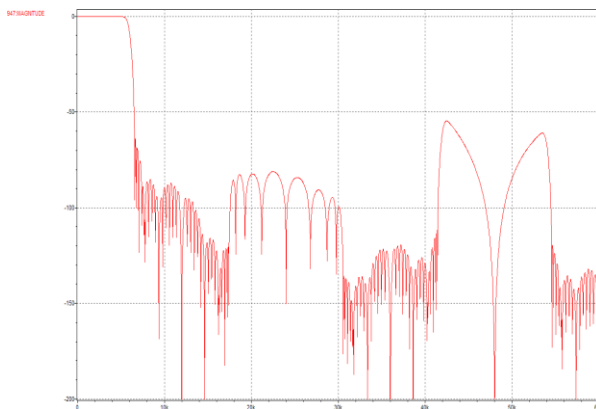
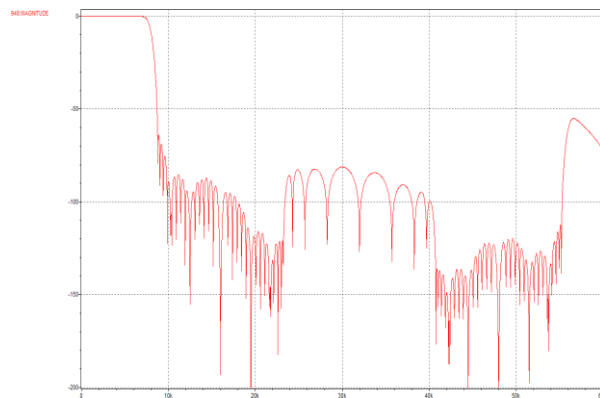
Table 133 Recommended Filter Configurations for Supported Sample Rates

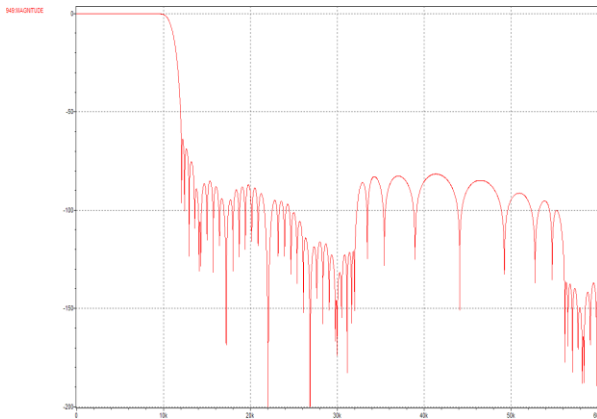
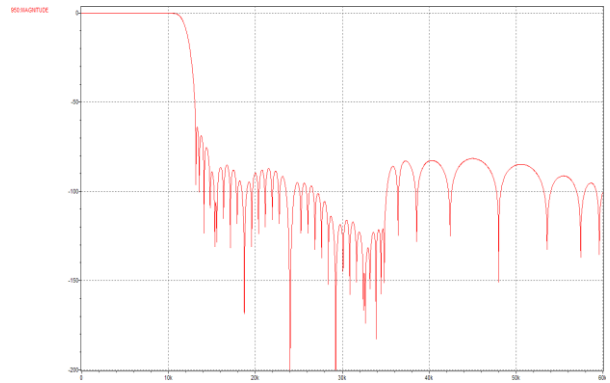
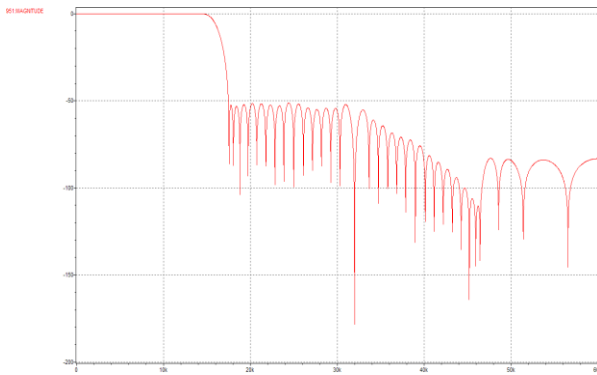
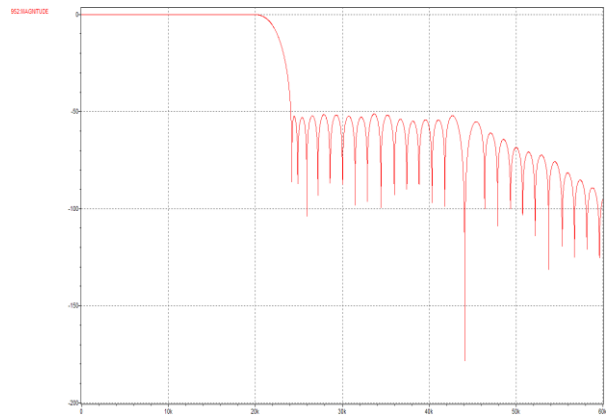
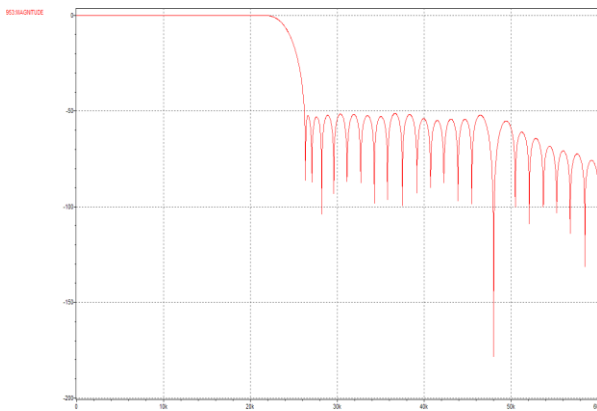
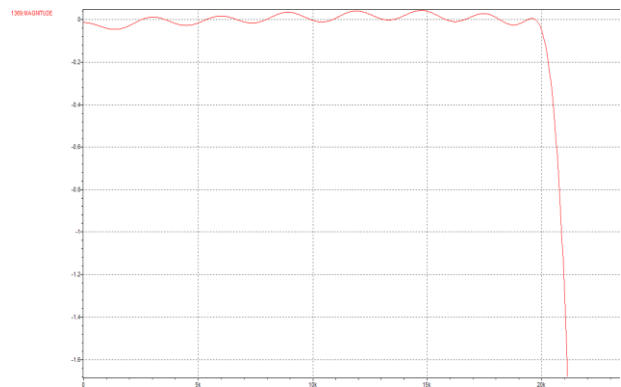
Figure 74 DAC Filter Response 8k Sampling Rate

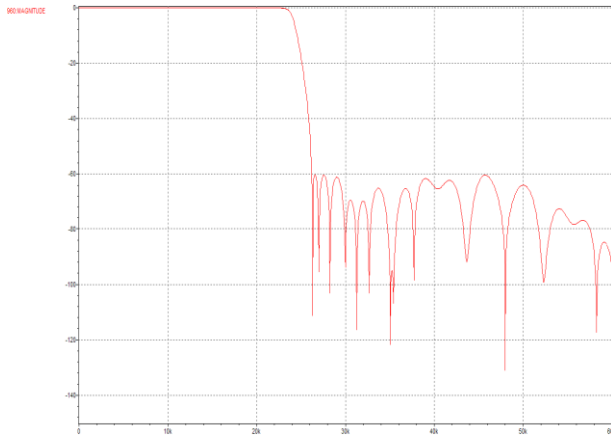
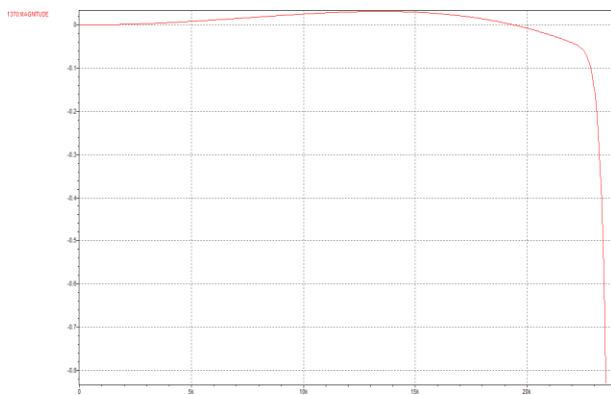
Figure 75 DAC Filter Response for 11.025k Sample Rate

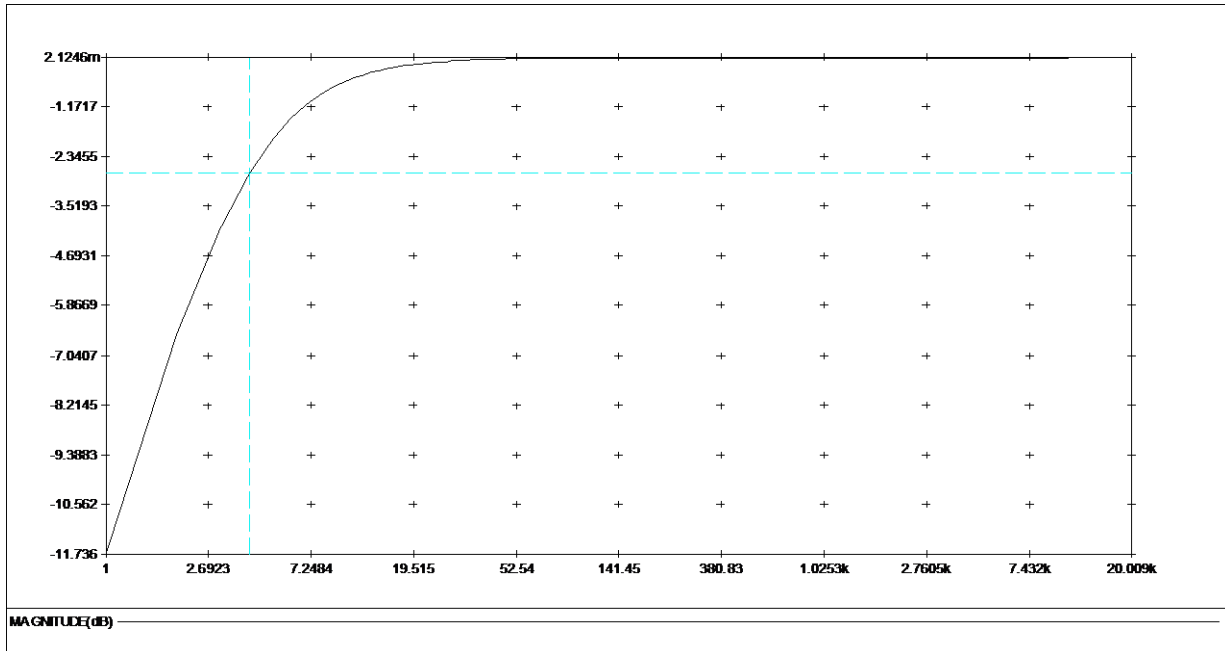
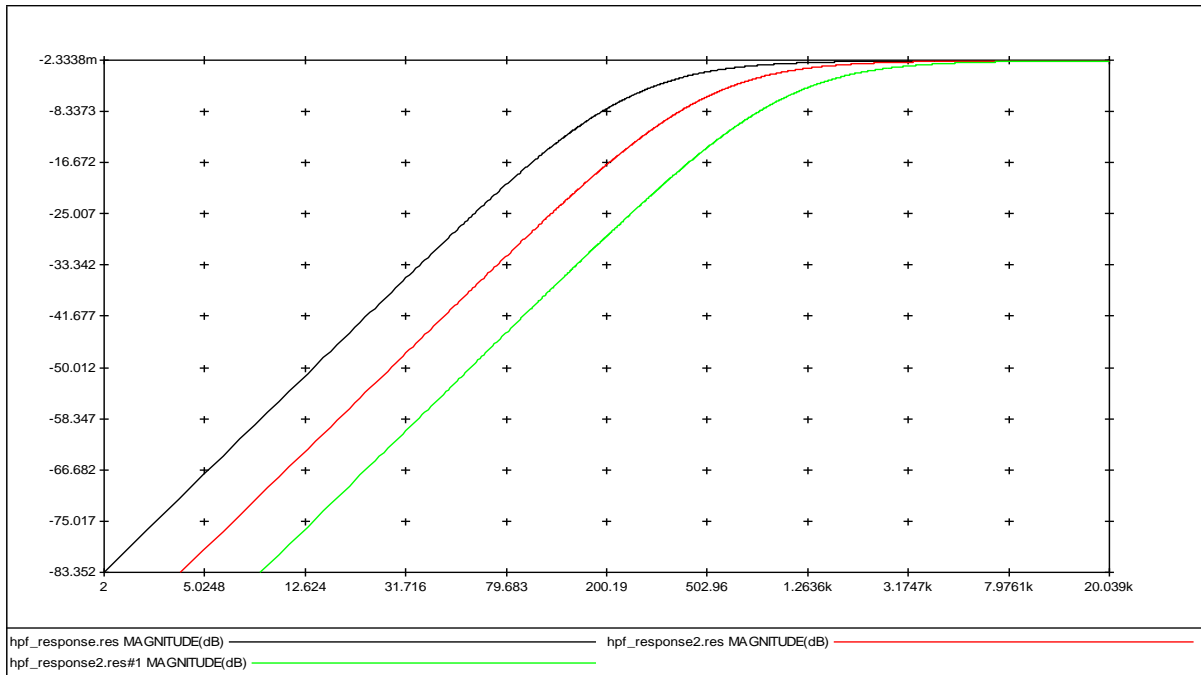
Figure 76 DAC Filter Response for 12k Sample Rate

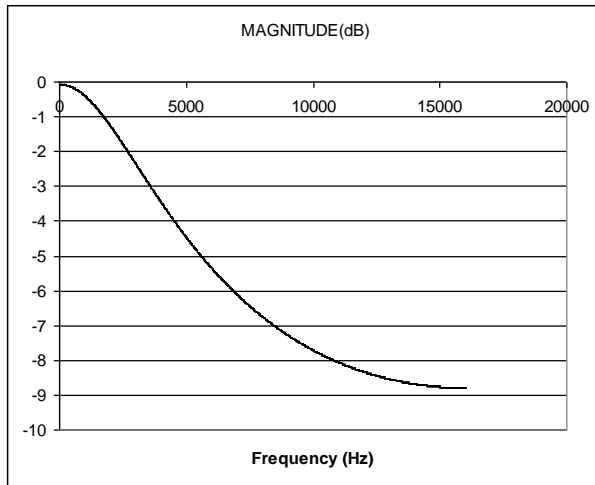
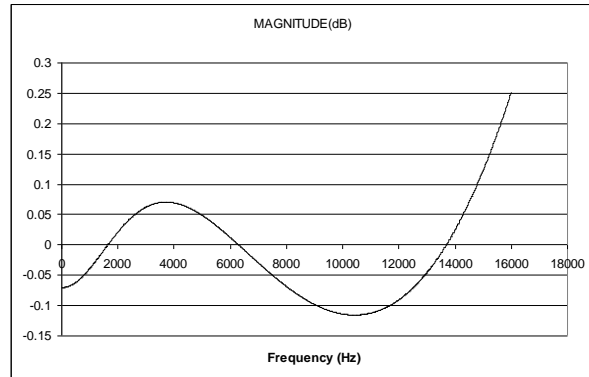
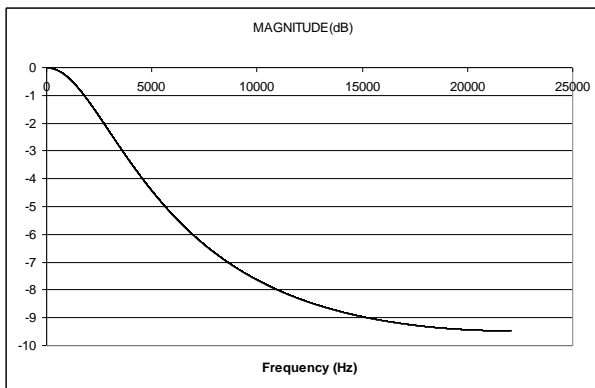
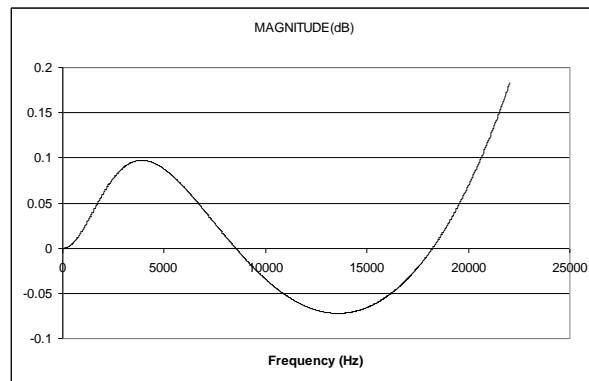
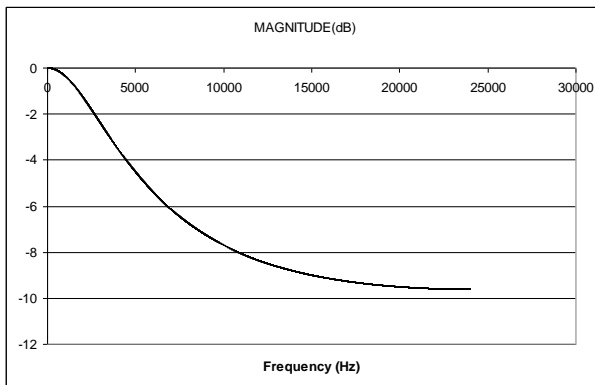
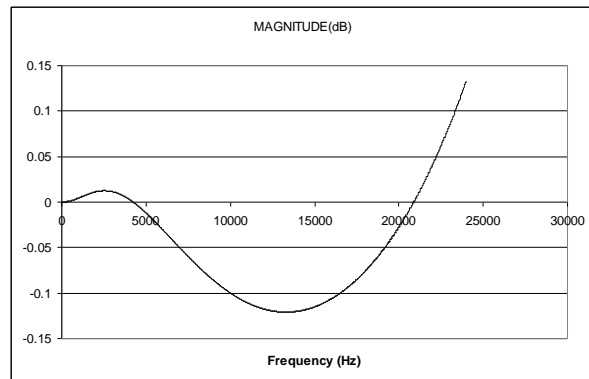
Figure 77 DAC Filter Response for 16k Sample Rate

Figure 78 DAC Filter Response 22.05k Sample Rate

Figure 79 DAC Playback Filter Response for 24k Sample Rate

Figure 80 DAC Playback Filter Response for 32k Sample Rate

Figure 81 DAC Playback Filter Response for 44.1k Sample Rate

Figure 82 DAC Playback Filter Response for 48k Sample Rate

Figure 83 DAC Playback Filter Passband Ripple for 44.1k Sample Rate (MCLK=11.2896MHZ)

ADC FILTER RESPONSES

Figure 84 ADC Digital Filter Frequency Response (128OSR)

Figure 85 ADC Digital Filter Passband Ripple (128OSR)

ADC HIGH PASS FILTER RESPONSES

Figure 86 ADC Digital High Pass Filter Frequency Response (48kHz, Hi-Fi Mode, ADC_HPF_CUT[1:0]=00)

Figure 87 ADC Digital High Pass Filter Ripple (48kHz, Voice Mode, ADC_HPF_CUT=01, 10 and 11)

DE-EMPHASIS FILTER RESPONSES

Figure 88 De-Emphasis Digital Filter Response (32kHz)

Figure 89 De-Emphasis Error (32kHz)

Figure 90 De-Emphasis Digital Filter Response (44.1kHz)

Figure 91 De-Emphasis Error (44.1kHz)

Figure 92 De-Emphasis Digital Filter Response (48kHz)

Figure 93 De-Emphasis Error (48kHz)

APPLICATIONS INFORMATION
ANALOGUE INPUT PATHS

The WM8962B provides up to 8 analogue audio input paths. Each of these inputs is referenced to the internal DC reference, VMID. A DC blocking capacitor is required for each analogue input pin used in the target application. The choice of capacitor is determined by the filter that is formed between that capacitor and the impedance of the input pin. The circuit is illustrated in Figure 94.

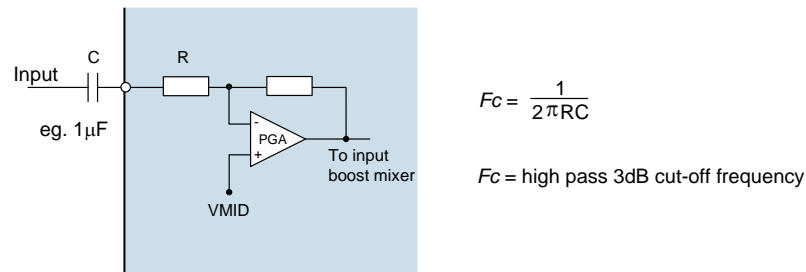

Figure 94 Audio Input Path DC Blocking Capacitor

In accordance with the WM8962B input pin resistance, it is recommended that a 1µF capacitance will give good results in most cases. Note that the input impedance, R, changes with the PGA gain setting, as described in the “Electrical Characteristics”.

A single capacitor is required for line or microphone input connection. Tantalum electrolytic capacitors are particularly suitable as they offer high stability in a small package size.

Ceramic equivalents are a cost effective alternative to the superior tantalum packages, but care must be taken to ensure the desired capacitance is maintained at the AVDD operating voltage. Also, ceramic capacitors may show microphonic effects, where vibrations and mechanical conditions give rise to electrical signals. This is particularly problematic for microphone input paths where a large signal gain is required.

The external connections for electret condenser microphones, incorporating the WM8962B microphone bias circuit, are shown later in the “Microphone Bias Circuit” section below.

MICROPHONE BIAS CIRCUIT

The WM8962B is designed to interface easily with analogue microphones. An electret condenser microphone (ECM) requires a bias current; this can be provided by the MICBIAS output on the WM8962B.

An electret condenser microphone may be connected in single-ended configuration, as illustrated in Figure 95.

A decoupling capacitor is required on the MICBIAS output. A suitable capacitor must be connected whenever the MICBIAS output is enabled.

A current-limiting resistor is also required for the ECM; the resistance should be chosen according to the minimum operating impedance of the microphone and MICBIAS voltage so that the maximum bias current of the WM8962B is not exceeded.

A 2.2kΩ current-limiting resistor is recommended; this provides compatibility with a wide range of microphone components.

Note that the MICBIAS output can also be used to power an analogue silicon microphone. In this case, the MICBIAS connects directly to the VDD pin of the microphone - a current-limiting resistor is not required in this case.

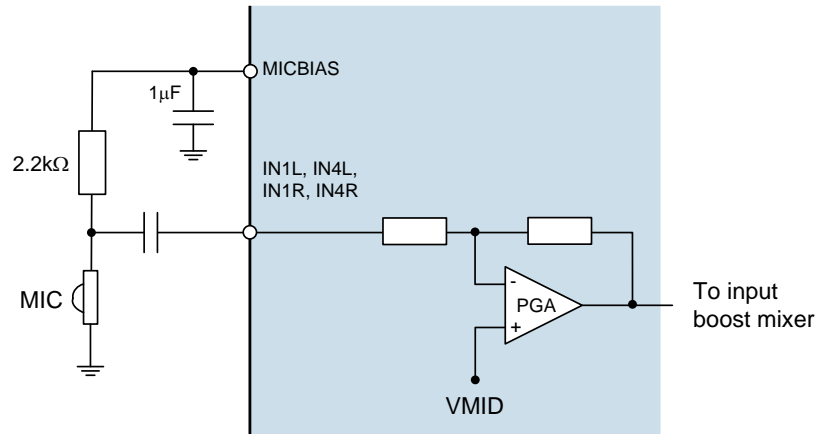

Figure 95 Single Ended Microphone Connection

Additional filtering of the MICBIAS output, to reduce noise and interference, may be implemented using the configuration illustrated in Figure 96.

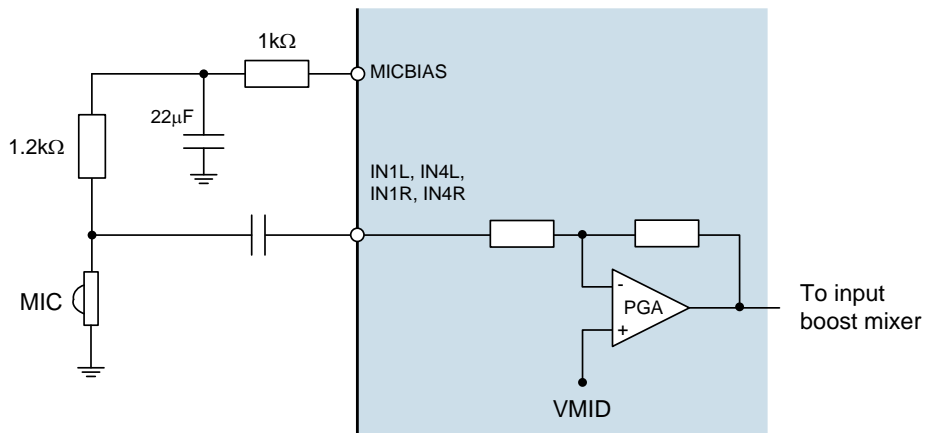

Figure 96 Microphone Connection, with MICBIAS filter components

CHARGE PUMP COMPONENTS

The WM8962B incorporates a Charge Pump circuit, which generates the CPVOUTP and CPVOUTN supply rails for the ground-referenced headphone drivers.

Decoupling capacitors are required on each of the Charge Pump outputs. A fly-back capacitor is also required. The recommended Charge Pump capacitors for WM8962B are detailed below in Table 134.

DESCRIPTION	CAPACITOR
CPVOUTP decoupling	Required capacitance is 2.0 μ F at 2V. Suitable component typically 4.7 μ F.
CPVOUTN decoupling	Required capacitance is 2.0 μ F at 2V. Suitable component typically 4.7 μ F.
Charge Pump fly-back (connect between C1CA and C1CB)	Required capacitance is 1.0 μ F at 2V. Suitable component typically 2.2 μ F.

Table 134 Charge Pump External Capacitors

Ceramic capacitors are recommended for these Charge Pump requirements. Note that, due to the wide tolerance of many types of ceramic capacitors, care must be taken to ensure that the selected components provide the required capacitance across the required temperature and voltage ranges in the intended application. Ceramic capacitors with X5R dielectric are recommended.

The positioning of the Charge Pump capacitors is important, particularly the fly-back capacitors. These capacitors should be placed as close as possible to the WM8962B.

RECOMMENDED EXTERNAL COMPONENTS DIAGRAM

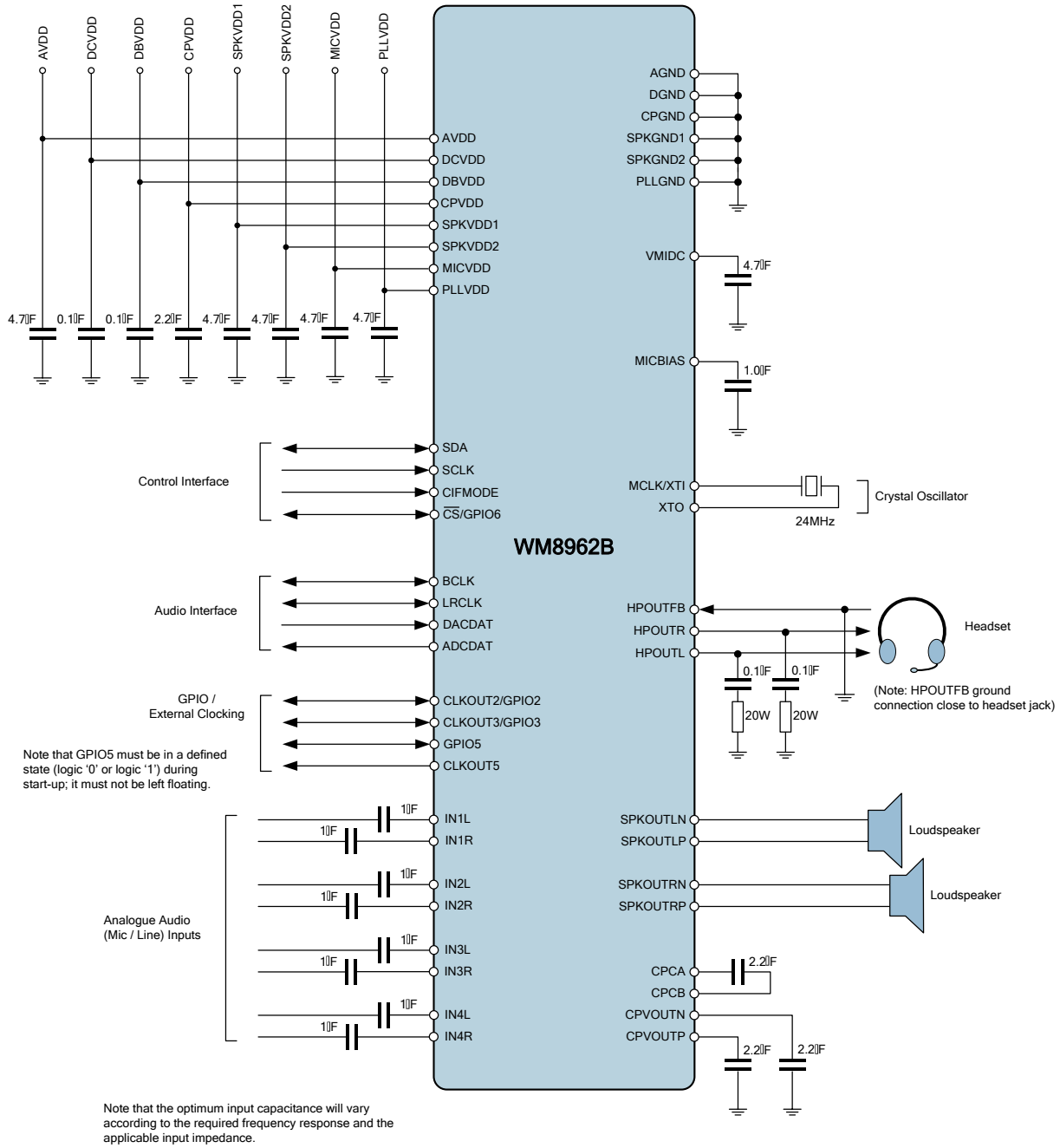

Figure 97 WM8962B Recommended External Components

Notes:
1. Power Supply Decoupling Capacitors

X5R ceramic capacitor is recommended for the power supply decoupling capacitors.

The decoupling capacitors on VMIDC, MICBIAS, CPVOUTP and CPVOUTN should be as close to the WM8962B as possible.

2. Charge Pump Capacitors

Specific recommendations for Charge Pump capacitors are provided in Table 135. Note that two different recommendations are provided for CPVOUTP and CPVOUTN; either of these components is suitable, depending upon size requirements and availability.

The positioning of the flyback capacitor is very important - this should be as close to the WM8962B as possible.

It is important to select a suitable capacitor type for the Charge Pump. Note that the capacitance may vary with DC voltage; care is required to ensure that required capacitance is achieved at the applicable operating voltage, as specified in Figure 97. The capacitor datasheet should be consulted for this information.

COMPONENT	REQUIRED CAPACITANCE	VALUE	PART NUMBER	VOLTAGE	TYPE	SIZE
Charge Pump Flyback (CPCA to CPCB)	$\geq 1\mu\text{F}$ at 2VDC	2.2 μF	Kemet C0402C225M9PAC	6.3v	X5R	0402
CPVOUTN decoupling, CPVOUTP decoupling	$\geq 2\mu\text{F}$ at 2VDC	2.2 μF	MuRata GRM188R61A225KE34D	10v	X5R	0603
		4.7 μF	MuRata GRM155R60J475M_EIA	6.3v	X5R	0402

Table 135 Charge Pump Capacitors

3. Zobel Networks

The Zobel network shown in Figure 97 is required on HPOUTL and HPOUTR whenever that output is enabled. Stability of these ground-referenced outputs across all process corners cannot be guaranteed without the Zobel network components. (Note that, if any ground-referenced output pin is not required, the Zobel network components can be omitted from the output pin, and the pin can be left floating.) The Zobel network requirement is detailed further in the applications note WAN_0212 "Class W Headphone Impedance Compensation".

Zobel networks should be positioned reasonably close to the WM8962B.

4. Crystal Oscillator

The WM8962B supports device clocking from either a digital clock source (compatible with timing and voltage threshold requirements) or from a crystal oscillator.

5. PLLGND Connection

The AGND and PLLGND pins must be tied together as close as possible to the WM8962B.

PCB LAYOUT CONSIDERATIONS

Poor PCB layout will degrade the performance and be a contributory factor in EMI, ground bounce and resistive voltage losses. All external components should be placed as close to the WM8962B device as possible, with current loop areas kept as small as possible.

The following layout priorities should be observed. (All these components should be as close to the WM8962B as possible; item 1. is the highest priority).

1. Crystal
2. Charge pump capacitors
3. AVDD, DCVDD, DBVDD decoupling
4. VMIDC, MICBIAS decoupling
5. Other decoupling
6. Zobel network components
7. CLKOUTn termination resistors

MIC DETECTION SEQUENCE USING MICBIAS CURRENT

This section details an example sequence which summarises how the host processor can configure and detect the events supported by the MICBIAS current detect function (see "MICBIAS Current Detect"):

- Mic insertion/removal
- Hook switch press/release

Figure 98 shows an example of how the MICBIAS current flow varies versus time, during mic insertion and hook switch events. The Y axis is annotated with the Mic detection thresholds, and the X axis is annotated with the stages of an example sequence as detailed in Table 136, to illustrate how the host processor can implement mic insertion and hook switch detection.

The sequence assumes that the microphone insertion and hook switch detection functions are monitored by polling the interrupt flags using the control interface. Note that the maximum mechanical bounce times for mic insertion and removal must be fully understood by the software programmer.

A GPIO pin could be used as an alternative mechanism to monitor the MICBIAS detection functions. This enables the host processor to detect mechanical bounce at any time.

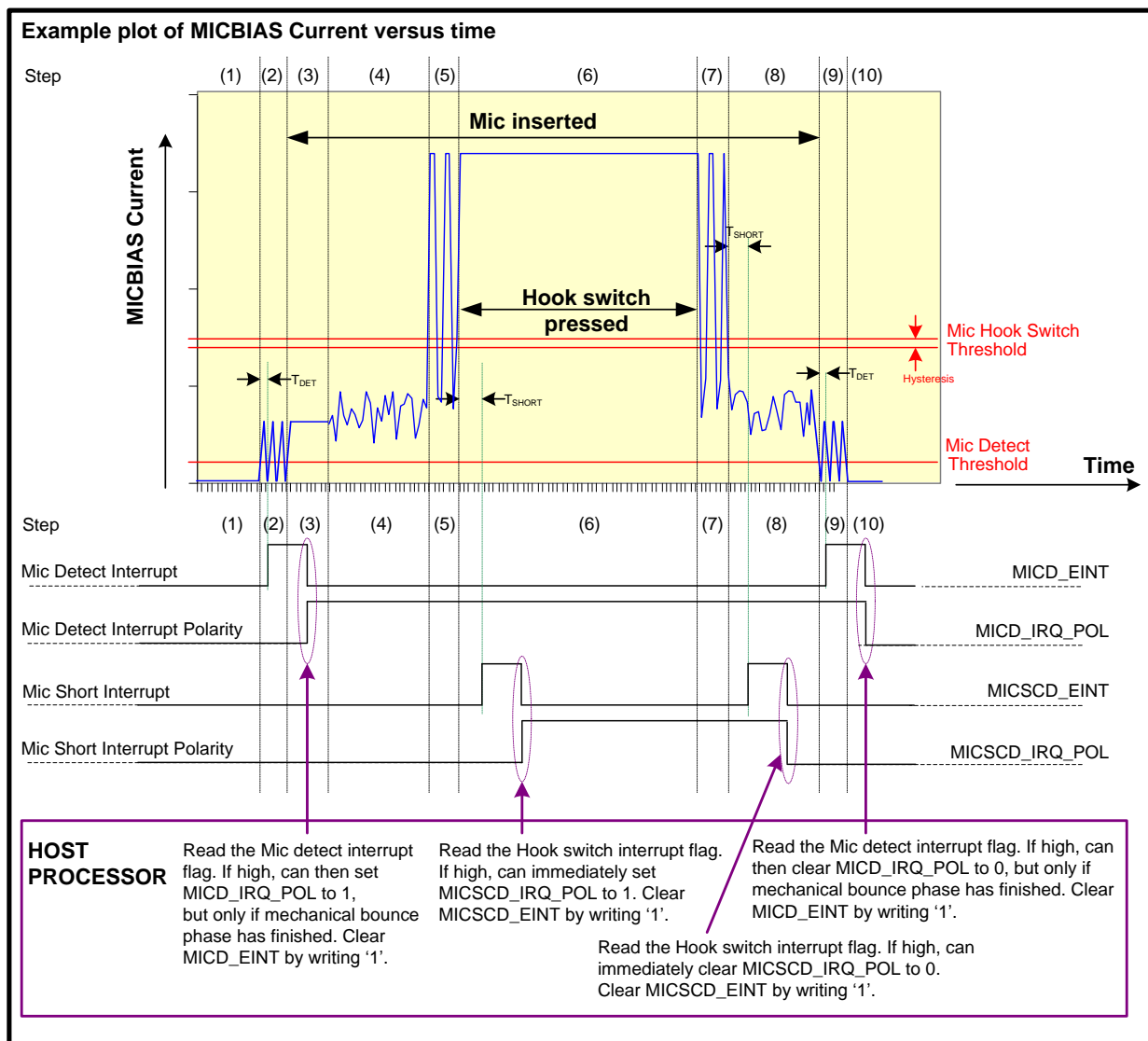
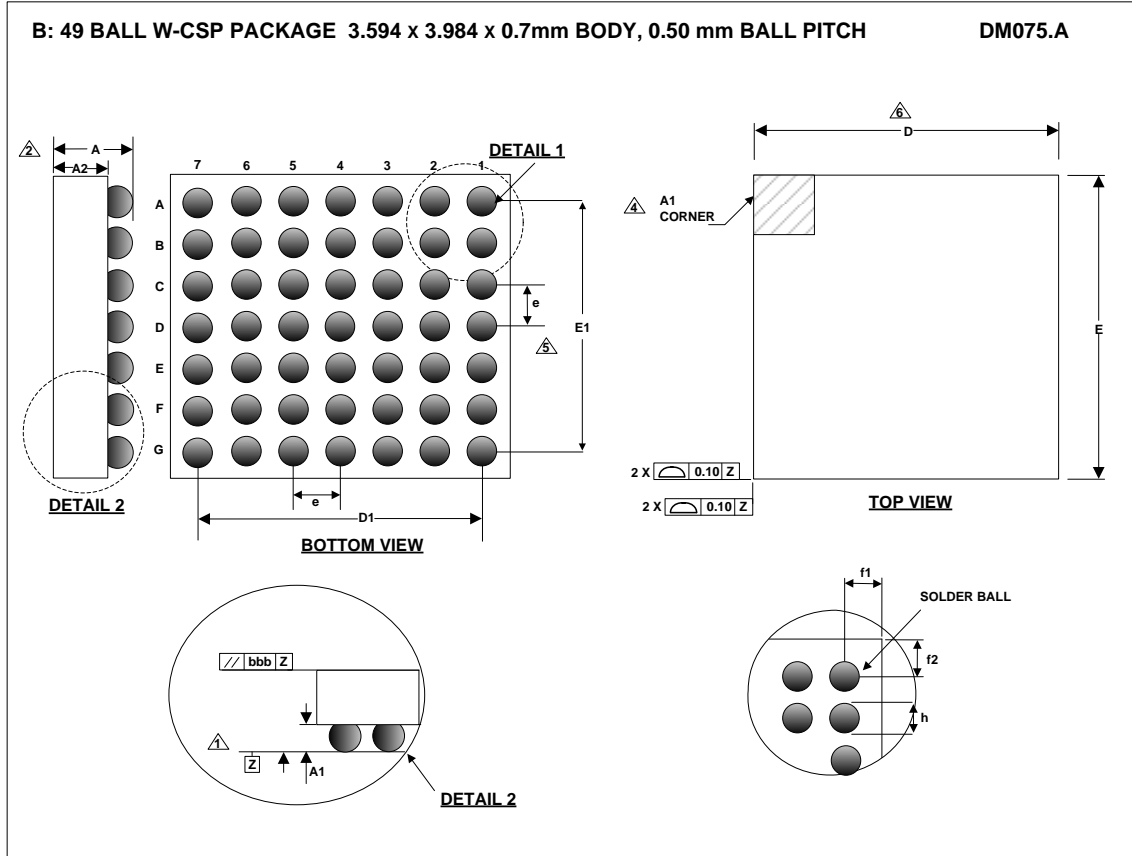

Figure 98 Mic Insert and Hook Switch Detect: Example MICBIAS Current Plot

1	Mic not inserted. To detect mic insertion, Host processor must initialise interrupts and clear MICD_IRQ_POL = 0. At every step, the host processor should poll the interrupt status register. Note that Mic Insertion de-bounce circuitry is automatically enabled.
2	Mechanical bounce of jack socket during Mic insertion. Host processor may already detect a mic insertion interrupt (MICD_EINT) during this step. Once detected, the host processor can set MICD_IRQ_POL = 1 and then clear the interrupt, unless mechanical bounce can last longer than the shortest possible T _{DET} , in which case the host processor should wait until step 3.
3	Mic fully inserted. If not already set, the host processor must now set MICD_IRQ_POL = 1. If not already cleared, the host processor must now clear the MICD_EINT interrupt. To detect Hook switch press, the host processor must clear MICSCD_IRQ_POL = 0. At this step, the diagram shows no AC current swing, due to a very low ambient noise level.
4	Mic fully inserted. Diagram shows AC current swing due to high levels of background noise (such as wind).
5	Mechanical bounce during hook switch press. The hook switch interrupt is unlikely to be set during this step, because 10 successive samples of the MICBIAS current exceeding the hook switch threshold have not yet been sampled. Note that Hook Switch de-bounce circuitry is automatically enabled.
6	Hook switch is fully pressed down. After T _{SHORT} , 10 successive samples of the MICBIAS current exceeding the hook switch threshold have been detected, hence a hook switch interrupt (MISCDC_EINT) will be generated. Once detected, the host processor can immediately set MICSCD_IRQ_POL = 1 and then clear the MISCDC_EINT interrupt.
7	Mechanical bounce during hook switch release. The hook switch interrupt is unlikely to be set during this step, because 10 successive samples of the MICBIAS current lower than the hook switch threshold have not yet been sampled.
8	Hook switch fully released. After T _{SHORT} , 10 successive samples of the MICBIAS current lower than the hook switch threshold have been detected, hence a hook switch interrupt (MISCDC_EINT) will be generated. Once detected, the host processor can immediately clear MICSCD_IRQ_POL = 0 and then clear the MISCDC_EINT interrupt.
9	Mechanical bounce of jack socket during Mic removal. Host processor may already detect a mic removal interrupt (MICD_EINT) during this step. Once detected, the host processor can clear MICD_IRQ_POL = 0 and then clear the interrupt, unless mechanical bounce can last longer than the shortest possible T _{DET} , in which case the host processor should wait until step 10.
10	Mic fully removed. If not already cleared, the host processor must now clear MICD_IRQ_POL = 0. If not already cleared, the host processor must now clear the MICD_EINT interrupt.

Table 136 Mic Insert and Hook Switch Detect: Example Sequence

Alternatively, utilising a GPIO pin to monitor the MICBIAS current detect functionality permits the host processor to monitor the steady state of microphone detection or hook switch press functions. Because the GPIO shows the steady state condition, software de-bounce may be easier to implement in the host processor, dependant on the processor performance characteristics, hence use of the GPIO is likely to simplify the rejection of mechanical bounce. Changes of state in the GPIO pin are also subject to the time delays t_{DET} and t_{SHORT}.

PACKAGE DIMENSIONS

Symbols	Dimensions (mm)			NOTE
	MIN	NOM	MAX	
A	0.650	0.7	0.750	
A1	0.219	0.244	0.269	
A2	0.431	0.456	0.481	
D	3.564	3.594	3.624	
D1		3.00 BSC		
E	3.954	3.984	4.014	
E1		3.00 BSC		
e		0.50 BSC		5
f1	0.282			
f2	0.477			
h		0.314 BSC		

NOTES:

1. PRIMARY DATUM -Z- AND SEATING PLANE ARE DEFINED BY THE SPHERICAL CROWNS OF THE SOLDER BALLS.
2. THIS DIMENSION INCLUDES STAND-OFF HEIGHT 'A1' AND BACKSIDE COATING.
3. A1 CORNER IS IDENTIFIED BY INK/LASER MARK ON TOP PACKAGE.
4. BILATERAL TOLERANCE ZONE IS APPLIED TO EACH SIDE OF THE PACKAGE BODY.
5. 'e' REPRESENTS THE BASIC SOLDER BALL GRID PITCH.
6. THIS DRAWING IS SUBJECT TO CHANGE WITHOUT NOTICE.
7. FOLLOWS JEDEC DESIGN GUIDE MO-211-C.

IMPORTANT NOTICE

Contacting Cirrus Logic Support

For all product questions and inquiries, contact a Cirrus Logic Sales Representative.

To find one nearest you, go to www.cirrus.com.

The products and services of Cirrus Logic International (UK) Limited; Cirrus Logic, Inc.; and other companies in the Cirrus Logic group ("Cirrus") are sold subject to Cirrus's terms and conditions of sale supplied at the time of order acknowledgement, including those pertaining to warranty, indemnification, and limitation of liability. Software is provided pursuant to applicable license terms. Cirrus reserves the right to make changes to its products and specifications or to discontinue any product or service without notice. Customers should therefore obtain the latest version of relevant information from Cirrus to verify that the information is current and complete. Testing and other quality control techniques are utilized to the extent Cirrus deems necessary. Specific testing of all parameters of each device is not necessarily performed. In order to minimize risks associated with customer applications, the customer must use adequate design and operating safeguards to minimize inherent or procedural hazards. Cirrus is not liable for applications assistance or customer product design. The customer is solely responsible for its selection and use of Cirrus products.

CERTAIN APPLICATIONS USING SEMICONDUCTOR PRODUCTS MAY INVOLVE POTENTIAL RISKS OF DEATH, PERSONAL INJURY, OR SEVERE PROPERTY OR ENVIRONMENTAL DAMAGE ("CRITICAL APPLICATIONS"). CIRRUS PRODUCTS ARE NOT DESIGNED, AUTHORIZED OR WARRANTED FOR USE IN PRODUCTS SURGICALLY IMPLANTED INTO THE BODY, AUTOMOTIVE SAFETY OR SECURITY DEVICES, NUCLEAR SYSTEMS, LIFE SUPPORT PRODUCTS OR OTHER CRITICAL APPLICATIONS. INCLUSION OF CIRRUS PRODUCTS IN SUCH APPLICATIONS IS UNDERSTOOD TO BE FULLY AT THE CUSTOMER'S RISK AND CIRRUS DISCLAIMS AND MAKES NO WARRANTY, EXPRESS, STATUTORY OR IMPLIED, INCLUDING THE IMPLIED WARRANTIES OF MERCHANTABILITY AND FITNESS FOR PARTICULAR PURPOSE, WITH REGARD TO ANY CIRRUS PRODUCT THAT IS USED IN SUCH A MANNER. IF THE CUSTOMER OR CUSTOMER'S CUSTOMER USES OR PERMITS THE USE OF CIRRUS PRODUCTS IN CRITICAL APPLICATIONS, CUSTOMER AGREES, BY SUCH USE, TO FULLY INDEMNIFY CIRRUS, ITS OFFICERS, DIRECTORS, EMPLOYEES, DISTRIBUTORS AND OTHER AGENTS FROM ANY AND ALL LIABILITY, INCLUDING ATTORNEYS' FEES AND COSTS, THAT MAY RESULT FROM OR ARISE IN CONNECTION WITH THESE USES.

This document is the property of Cirrus and by furnishing this information, Cirrus grants no license, express or implied, under any patents, mask work rights, copyrights, trademarks, trade secrets or other intellectual property rights. Any provision or publication of any third party's products or services does not constitute Cirrus's approval, license, warranty or endorsement thereof. Cirrus gives consent for copies to be made of the information contained herein only for use within your organization with respect to Cirrus integrated circuits or other products of Cirrus, and only if the reproduction is without alteration and is accompanied by all associated copyright, proprietary and other notices and conditions (including this notice). This consent does not extend to other copying such as copying for general distribution, advertising or promotional purposes, or for creating any work for resale. This document and its information is provided "AS IS" without warranty of any kind (express or implied). All statutory warranties and conditions are excluded to the fullest extent possible. No responsibility is assumed by Cirrus for the use of information herein, including use of this information as the basis for manufacture or sale of any items, or for infringement of patents or other rights of third parties. Cirrus Logic, Cirrus, the Cirrus Logic logo design, SoundClear, WISCE, ReTune, and SilentSwitch are among the trademarks of Cirrus. Other brand and product names may be trademarks or service marks of their respective owners.

Copyright © 2011–2015 Cirrus Logic, Inc. All rights reserved.

REVISION HISTORY

DATE	REV	DESCRIPTION OF CHANGES	PAGE	CHANGED BY
19/12/11	1.0	First Release		
16/04/12	2.0	MICBIAS_EVR definition updated		
10/05/12	2.0	Thermal characteristics updated, and more details added		
11/05/12	2.0	Product status changed to Preliminary Technical Data		
11/05/12	2.0	1W changed to 2W in title, p1		
25/05/12	3.0	Update to comments regarding MICBIAS filtering components		
25/06/12	3.0	Speaker Supply Leakage Current moved to the Current Consumption section of the Electrical Characteristics. Added new section in Electrical Characteristics for DAC to Stereo 4ohm Speaker performance. Updated typical values for MICBIAS voltages. Added typical Output Noise values for each available MICBIAS level.		
25/06/12	3.0	Product status updated to pre-production.		
30/08/12	4.0	Product status updated to production data Updates to the Electrical Characteristics Updated ADC oversampling rate description.		
04/04/13	4.1	Noted that I2C addresses 94h and D2h are reserved, and must not be used on the same bus as WM8962B.		
30/01/14	4.2	Additions to the recommended DSP control sequences. Additional requirements for writing 24-bit DSP configuration registers. Correction to the inconsistent descriptions of the SPKOUTL/R_PGA_MUTE bits. Digital Core block diagram updated, consistent with ADC Enhancements functions (Second Order Filter is included within ADC Enhancements). Correction to control sequence for multiple push-button detection.	72-76 72, 188 122 94 44	PH
22/07/14	4.2	DF1 filter as input to DRC is deleted	84, 86	PH