

## PCN – Process Change Notification

Change:	A.01.C.301111.wm
Date:	2016/05/25
Author	Kim Ho

### Affected Products

Model#	Part Number	Changes
Hercules Screw-Mount GPS Antenna with 3M RG174 SMA(M) mounted on L Wall Bracket.	A.01.C.301111.wm	Amend dimension.

### Type of Change

- Hardware Modification  
 Production Process Advance  
 Others – Amend dimension.

### Description of Change

- Amended the dimension from L bracket to connector.

### Schedule

2016, May, Taoglas will input this new dimension into drawing.

### Forecast Estimated Transition Date

**MAY/2016**

### Illustration of Change

#### Old drawing

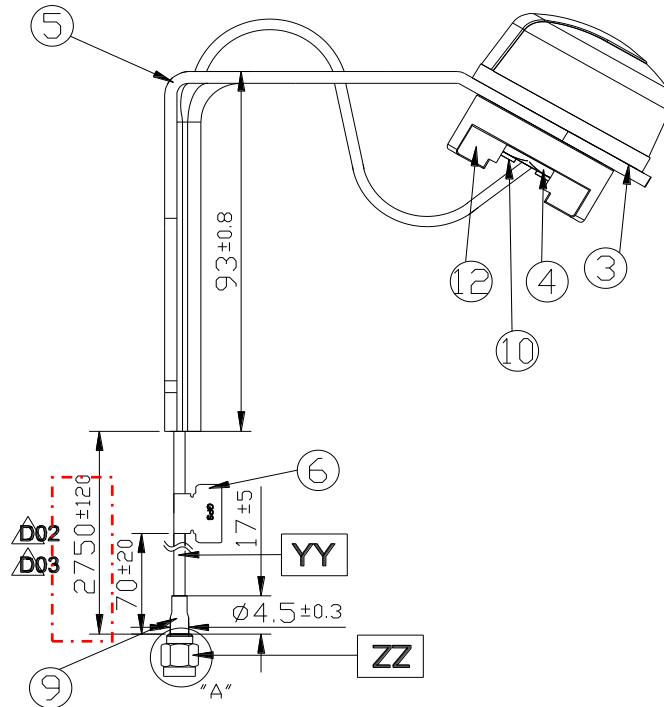

#### New drawing

