

THIS DRAWING IS UNPUBLISHED.

RELEASED FOR PUBLICATION

REVISIONS

© COPYRIGHT - TE Connectivity Ltd.

ALL RIGHTS RESERVED.

P	LTR	DESCRIPTION	DATE	DWN	APVD
	C	REVISED PER ECO-20-000891	14JAN2019	SJ	JH

GENERAL TOLERANCE : ±0.1

AS SHOWN 2108964-1

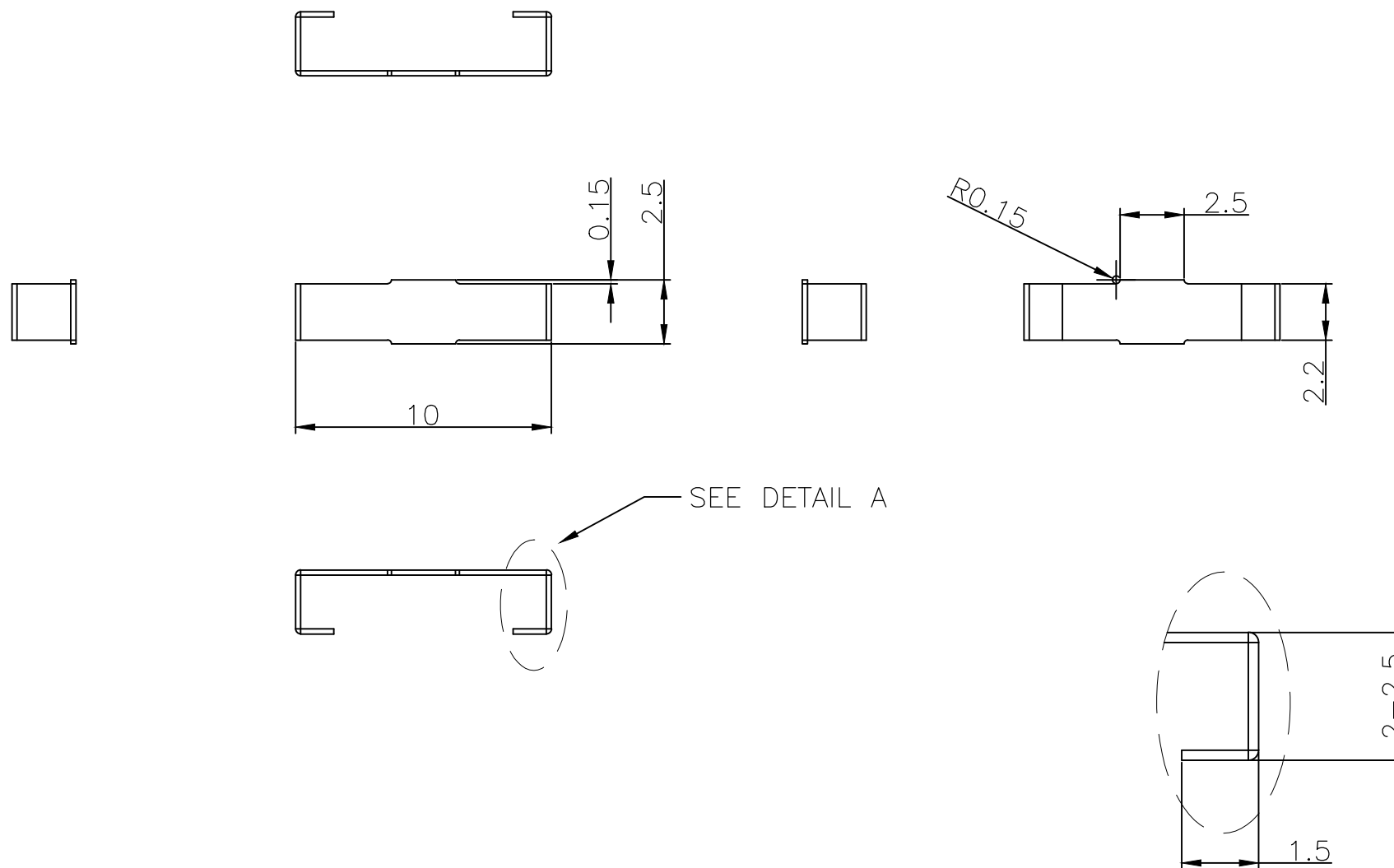

SEE DETAIL A

DETAIL A
SCALE 8:1

NOTE

- ① Material : Electrolytic Tin Plate
- ② Thickness : 0.2 t
- ③ Finish (Plating Spec.)
 - Under Ni Plating : 1~3um micro meter
 - Matt Tin Ni Plating : 2~5um micro meter
- ④ PACKING MATERIAL MUST BE TAPE AND REEL

THIS DRAWING IS A CONTROLLED DOCUMENT.		DWN SJ.NOH	24MAY2017	STE TE Connectivity													
DIMENSIONS: mm		CHK -	-														
TOLERANCES UNLESS OTHERWISE SPECIFIED:		APVD JH.KIM	24MAY2017	NAME STAMPING ELEMENT FOR WIFI ANTENNA													
<table border="0"> <tr><td>0 PLC</td><td>± -</td></tr> <tr><td>1 PLC</td><td>± -</td></tr> <tr><td>2 PLC</td><td>± -</td></tr> <tr><td>3 PLC</td><td>± -</td></tr> <tr><td>4 PLC</td><td>± -</td></tr> <tr><td>ANGLES</td><td>± -</td></tr> </table>		0 PLC	± -	1 PLC	± -	2 PLC	± -	3 PLC	± -	4 PLC	± -	ANGLES	± -	PRODUCT SPEC -	-	APPLICATION SPEC -	
0 PLC	± -																
1 PLC	± -																
2 PLC	± -																
3 PLC	± -																
4 PLC	± -																
ANGLES	± -																
MATERIAL -	FINISH -	WEIGHT 0.1[g]	A3	CAGE CODE 00779	DRAWING NO C-2108964												
CUSTOMER DRAWING			SCALE 1:1	SHEET 1 OF 2	REV C												

THIS DRAWING IS UNPUBLISHED.

RELEASED FOR PUBLICATION

© COPYRIGHT - TE Connectivity Ltd.

ALL RIGHTS RESERVED.

REVISIONS

P	LTR	DESCRIPTION	DATE	DWN	APVD
-	-	SEE SHEET 1	-	-	-

GENERAL TOLERANCE : ±0.1

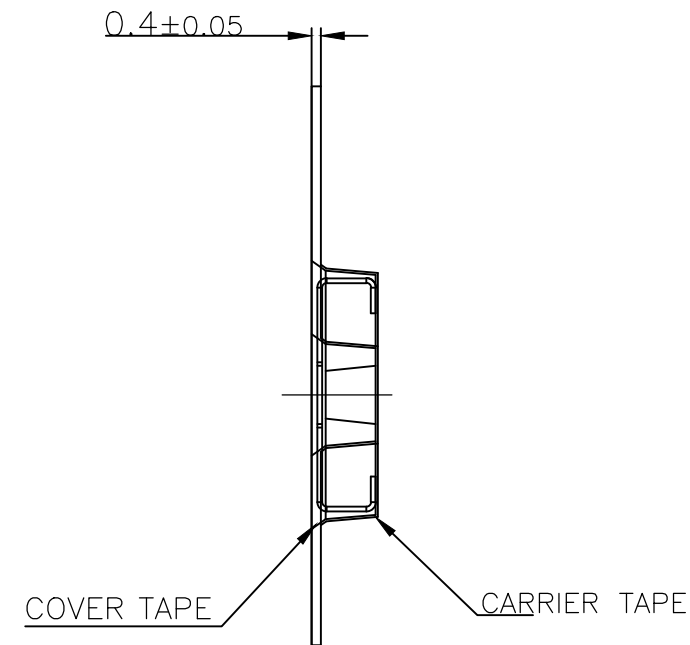
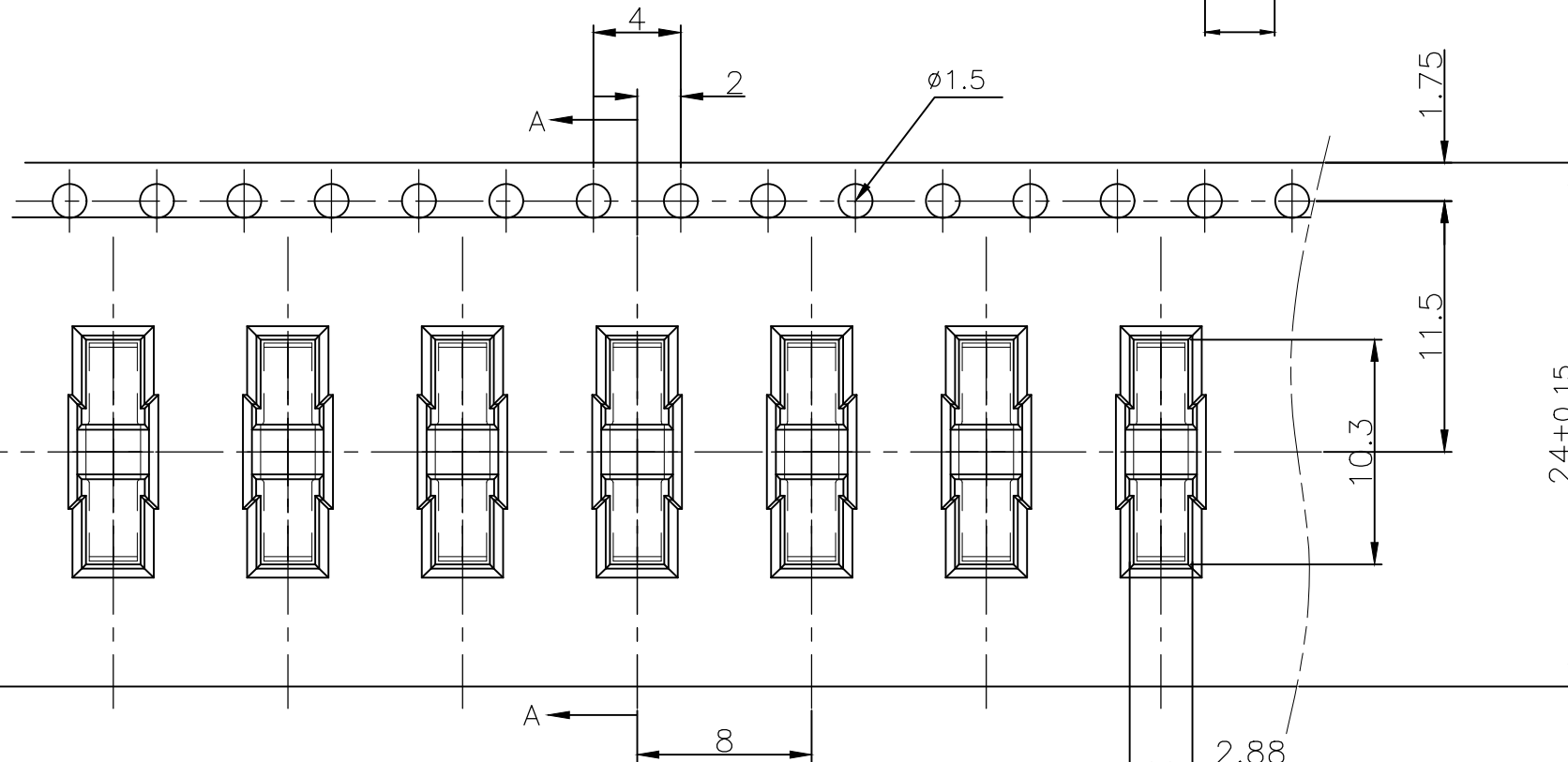
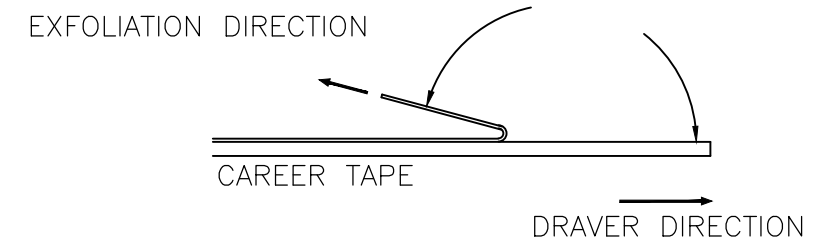
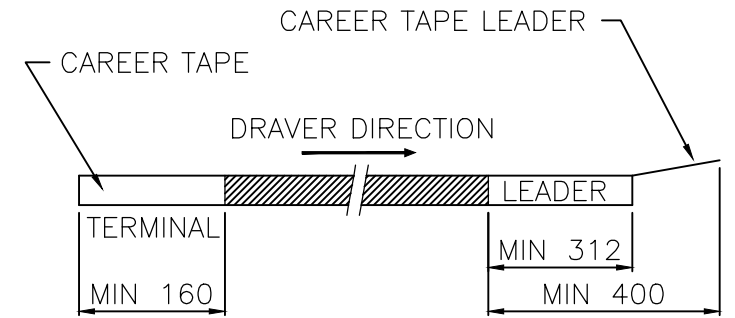
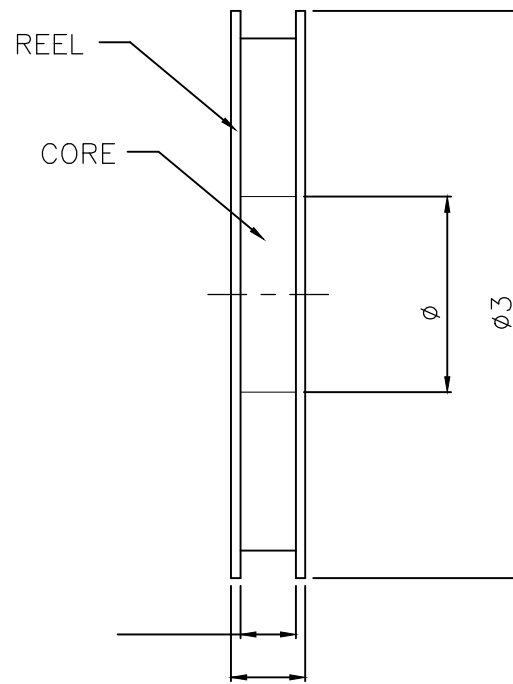
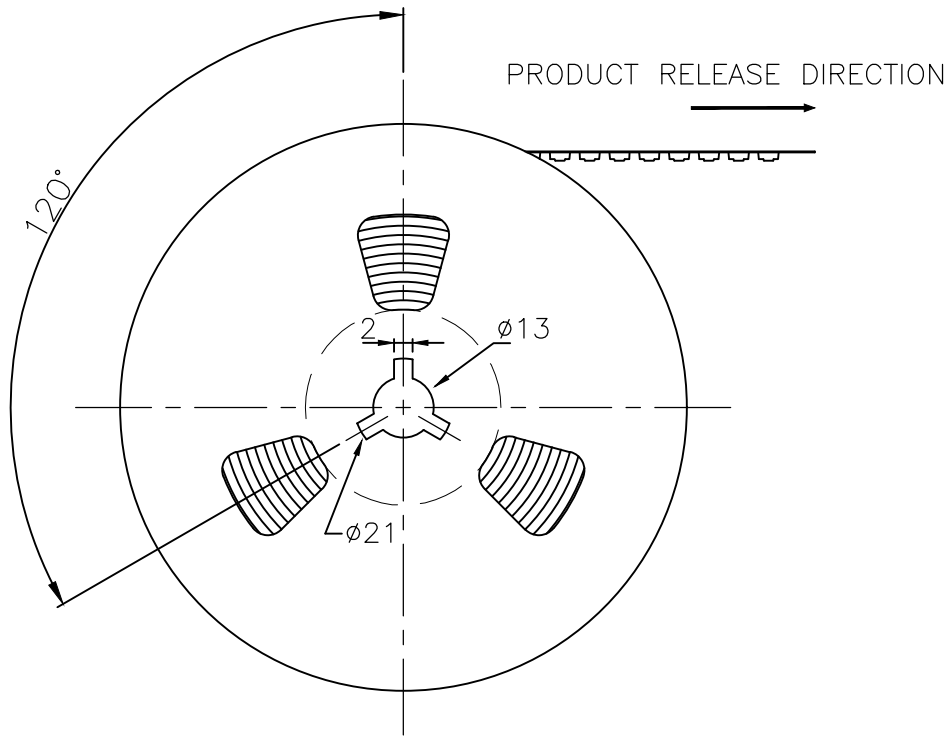

THIS DRAWING IS A CONTROLLED DOCUMENT.

DIMENSIONS: mm		TOLERANCES UNLESS OTHERWISE SPECIFIED:	
	0 PLC	±	-
	1 PLC	±	-
	2 PLC	±	-
	3 PLC	±	-
	4 PLC	±	-
	ANGLES	±	-
MATERIAL		FINISH	
-		-	

DWN	SJ.NOH	24MAY2017
CHK	-	-
APVD	JH.KIM	24MAY2017
PRODUCT SPEC	-	-
APPLICATION SPEC	-	-
WEIGHT	0.1[g]	-

STE TE Connectivity

STAMPING ELEMENT FOR WIFI ANTENNA

NAME	SIZE	CAGE CODE	DRAWING NO	RESTRICTED TO
-	A3	00779	C-2108964	-
CUSTOMER DRAWING		SCALE	SHEET	REV
-		1:1	2 OF 2	C