

Features

- Operates DC - 4 GHz on Single Supply
- ASIC TTL / CMOS Driver
- Leadless 4 x 7 mm Chip Scale Plastic Package
- Low DC Power Consumption
- 50 Ohm Nominal Impedance
- Test Boards are Available
- Tape and Reel are Available
- Lead-Free CSP-2 Package
- 100% Matte Tin Plating over Copper
- Halogen-Free “Green” Mold Compound
- 260°C Reflow Compatible
- RoHS* Compliant Version of SW90-0004A

Description

M/A-COM's MASWCC0006 is a SP6T absorptive pHEMT switch with integral TTL driver. This device is in an MLP plastic surface mount package. This switch offers excellent broadband performance and repeatability from DC to 4 GHz, while maintaining low DC power dissipation. The MASWCC0006 is ideally suited for wireless infrastructure applications.

Pin Configuration^{1,2,3,4}

Pin No.	Function	Pin No.	Function
1	CP2	19	GND
2	V _{EE}	20	NC
3	NC	21	GND
4	C6	22	RFC
5	C5	23	GND
6	C4	24	GND
7	C3	25	RF4
8	C2	26	GND
9	C1	27	RF5
10	NC	28	GND
11	GND	29	RF6
12	NC	30	GND
13	GND	31	NC
14	RF1	32	V _{EE}
15	GND	33	V _{CC}
16	RF2	34	NC
17	GND	35	V _{CC}
18	RF3	36	CP1

Ordering Information

Part Number	Package
MASWCC0006	Bulk Packaging
MASWCC0006TR	1000 piece reel
MASWCC0006-TB	Sample Test Board

Note: Reference Application Note M513 for reel size information.

1. NC = No Connection
2. For single supply operation V_{EE} is internally generated and must remain isolated from external power supplies. Generated noise is typical of switching DC-DC Converters.
3. Connections and external components shown in functional schematic are required. 0.1µF Capacitors need to be located near pins 32 & 33.
4. The exposed pad centered on the package bottom must be connected to RF and DC ground. (For MLF Packages)

* Restrictions on Hazardous Substances, European Union Directive 2002/95/EC.

GaAs SP6T Switch, Absorptive, Single Supply DC - 4.0 GHz

Rev. V4

Electrical Specifications: $T_A = 25^\circ\text{C}$

Parameter	Test Conditions	Frequency	Units	Min.	Typ.	Max.
Insertion Loss	RFC-RF1, 2, 3, 4, 5, 6	DC - 3.0 GHz	dB	—	—	2.1
		3.0 - 4.0 GHz	dB	—	—	2.4
Isolation	—	DC - 4.0 GHz	dB	25	—	—
VSWR	On (RFC, RF1-RF6) Logic per Truth Table Off (RF1-RF6) Logic per Truth Table	DC - 4.0 GHz	Ratio	—	—	2.0:1
		DC - 4.0 GHz	Ratio	—	—	2.0:1
1 dB Compression	— —	50 MHz	dBm	—	15	—
		0.5 - 4.0 GHz	dBm	—	27	—
Input IP_3	Two-tone inputs up to +5 dBm	50 MHz	dBm	—	30	—
		0.5-4.0 GHz	dBm	—	40	—
Switching Speed	Ton (50% Control to 90% RF)	—	ns	—	20	—
	Toff (50% Control to 10% RF)	—	ns	—	15	—
	Trise (10% to 90% RF)	—	ns	—	5	—
	Tfall (90% to 10% RF)	—	ns	—	2	—
V_{CC}	—	—	V	4.5	5.0	5.5
V_{IL} V_{IH}	LOW-level input voltage HIGH-level input voltage	—	V	0.0	—	0.8
		—	V	2.0	—	5.0
I_{in} (Input Leakage Current)	$V_{in} = V_{CC}$ or GND	—	μA	-1.0	—	1.0
$I_{CC}^{5,7}$	V_{CC} min to max, Logic "0" or "1"	—	mA	—	5	8
I_{CC}^8 (Quiescent Supply Current)	$V_{cntrl} = V_{CC}$ or GND	—	μA	—	250	400
Turn-on Current ⁶	For guaranteed start-up	—	mA	—	—	125
ΔI_{CC} (Additional Supply Current Per TTL Input Pin)	$V_{CC} = \text{Max}$, $V_{cntrl} = V_{CC} - 2.1\text{ V}$	—	mA	—	—	1.0
Switching Noise	Generated from DC-DC Converter with recommended capacitors	3.5 MHz	dBm	—	-93	—
Thermal Resistance θ_{jc}	—	—	$^\circ\text{C/W}$	—	15	—

5. During turn-on, the device requires an initial start up current (I_{CC}) specified as "Turn-on Current". Once operational, I_{CC} will drop to the specified levels. This is not applicable to dual supply operation.
6. The DC-DC converter is guaranteed to start in 100 μs as long as the power supplies have the maximum turn-on current available for start-up.
7. For single supply operation
8. For dual supply operation

Truth Table (Switch)

Control Inputs "0" is TTL Low, "1" is TTL High						Condition of Switch RF Common to Each RF Port					
C1	C2	C3	C4	C5	C6	RF1	RF2	RF3	RF4	RF5	RF6
1	0	0	0	0	0	On	Off	Off	Off	Off	Off
0	1	0	0	0	0	Off	On	Off	Off	Off	Off
0	0	1	0	0	0	Off	Off	On	Off	Off	Off
0	0	0	1	0	0	Off	Off	Off	On	Off	Off
0	0	0	0	1	0	Off	Off	Off	Off	On	Off
0	0	0	0	0	1	Off	Off	Off	Off	Off	On

2

M/A-COM Technology Solutions Inc. (MACOM) and its affiliates reserve the right to make changes to the product(s) or information contained herein without notice. Visit www.macom.com for additional data sheets and product information.

GaAs SP6T Switch, Absorptive, Single Supply DC - 4.0 GHz

Rev. V4

Absolute Maximum Ratings ^{9,10}

Parameter	Absolute Maximum
Max. Input Power 0.05 GHz 0.5 - 4.0 GHz ¹¹	+27 dBm +34 dBm
V_{CC} ⁷	$-0.5V \leq V_{CC} \leq +6.0V$
V_{CC} ⁸	$-0.5V \leq V_{CC} \leq +7.0V$
V_{EE} ⁸	$-8.5V \leq V_{EE} \leq +0.5V$
$V_{CC} - V_{EE}$ ⁸	$-0.5V \leq V_{CC} - V_{EE} \leq 14.5V$
V_{in} ¹²	$-0.5V \leq V_{in} \leq V_{CC} + 0.5V$
Operating Temperature	-40°C to +85°C
Storage Temperature	-65°C to +125°C

9. Exceeding any one or combination of these limits may cause permanent damage to this device.
10. M/A-COM does not recommend sustained operation near these survivability limits.
11. When the RF input is applied to the terminated port, the absolute maximum power is +30 dBm.
12. Standard CMOS TTL interface, latch-up will occur if logic signal is applied prior to power supply.

Handling Procedures

Please observe the following precautions to avoid damage:

Static Sensitivity

Gallium Arsenide Integrated Circuits are sensitive to electrostatic discharge (ESD) and can be damaged by static electricity. Proper ESD control techniques should be used when handling these devices.

Recommended PCB Configuration

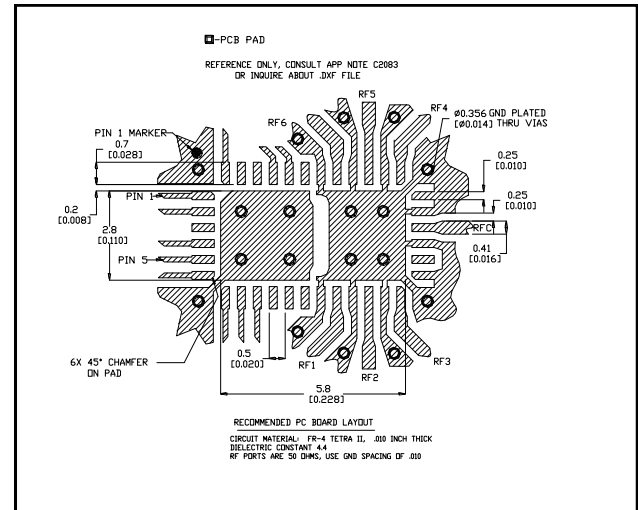

Typical Performance Curves

Insertion Loss vs. Frequency

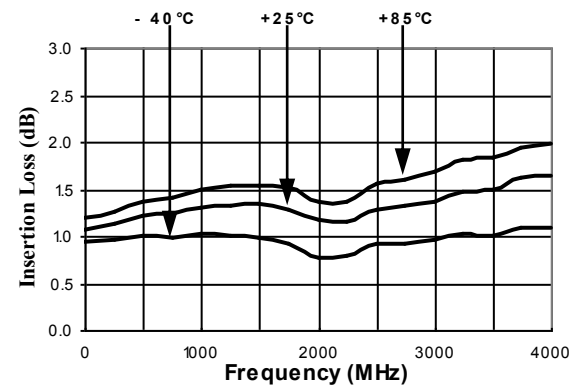

Isolation (dB) vs. Frequency

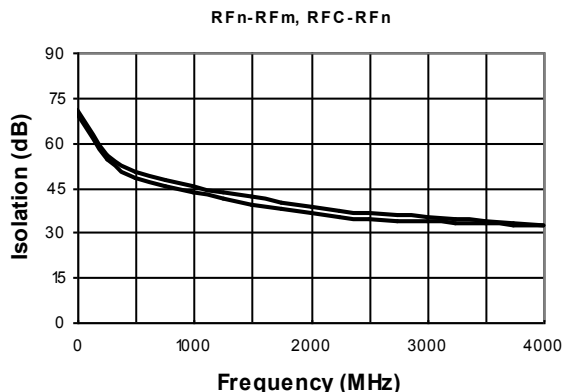

On VSWR vs. Frequency

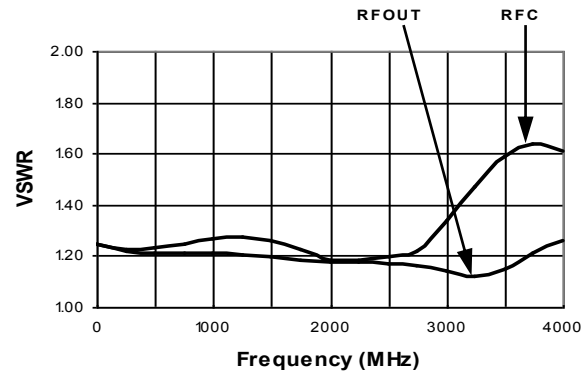

Typical Performance Curves

VSWR (Terminations) vs. Frequency

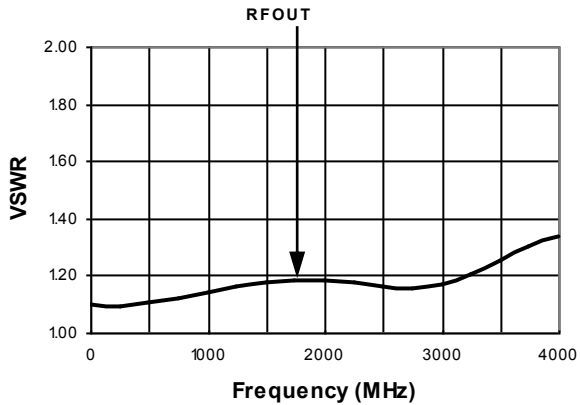

IP3 Results ¹¹

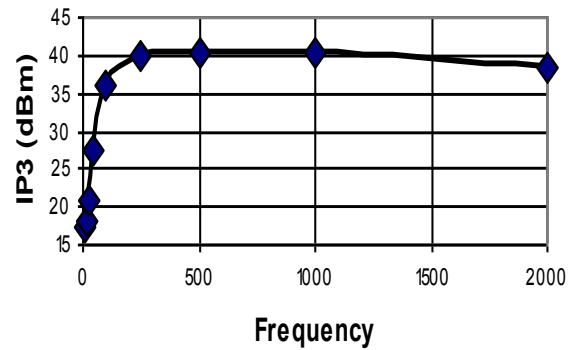

11. All testing done with the second tone 5 MHz above the frequency on the plot, except for the 10 MHz point, where the second tone is at 11 MHz. Both tones are +5 dBm.

Functional Schematic

Single Supply Operation
Vcc = +5V

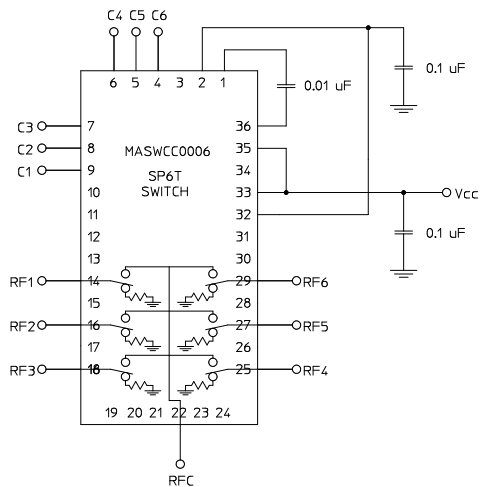

Dual Supply Operation
Vcc = +5V
Vee = -5V to -8V

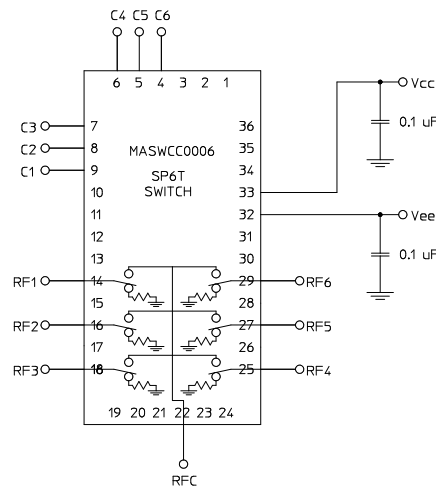

**GaAs SP6T Switch, Absorptive, Single Supply
DC - 4.0 GHz**

Rev. V4

**CSP-2, Lead-Free 4 x 7 mm, 36-lead
PQFN†**

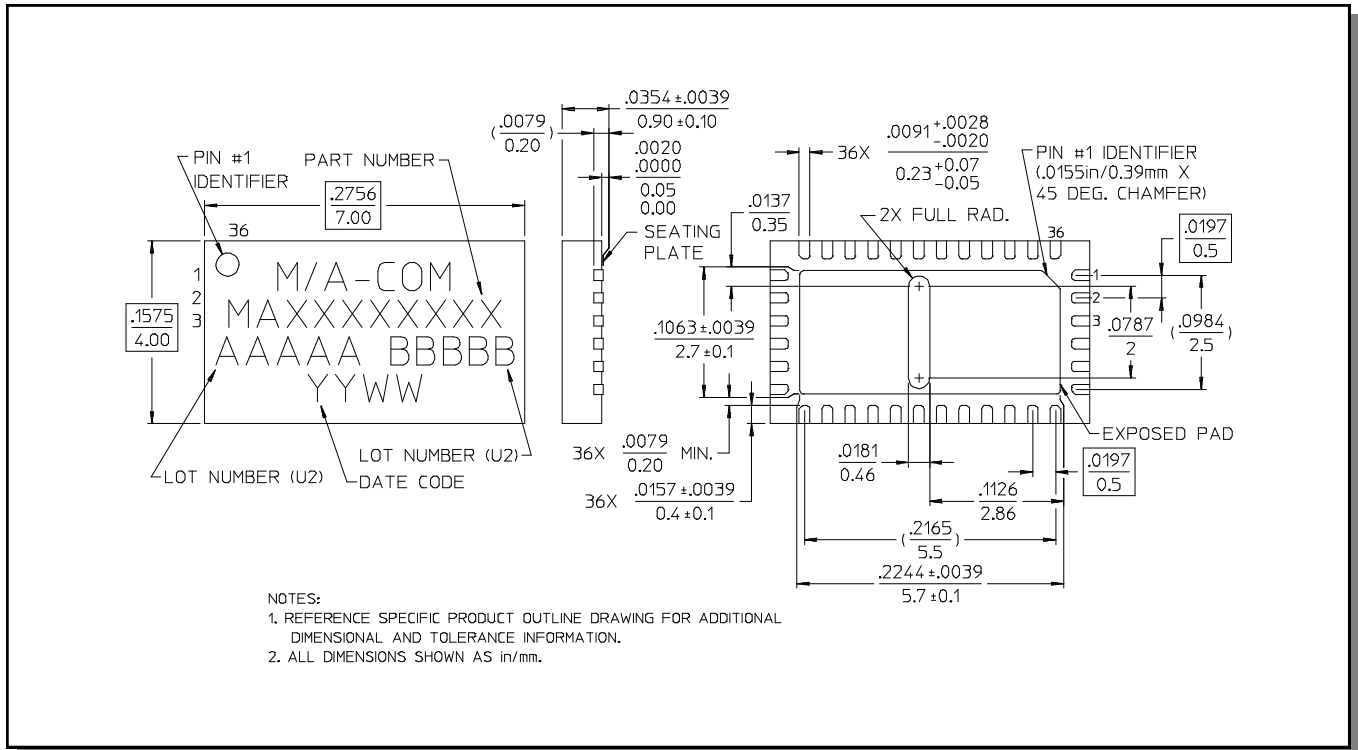

† Reference Application Note M538 for lead-free solder reflow recommendations.

M/A-COM Technology Solutions Inc. All rights reserved.

Information in this document is provided in connection with M/A-COM Technology Solutions Inc ("MACOM") products. These materials are provided by MACOM as a service to its customers and may be used for informational purposes only. Except as provided in MACOM's Terms and Conditions of Sale for such products or in any separate agreement related to this document, MACOM assumes no liability whatsoever. MACOM assumes no responsibility for errors or omissions in these materials. MACOM may make changes to specifications and product descriptions at any time, without notice. MACOM makes no commitment to update the information and shall have no responsibility whatsoever for conflicts or incompatibilities arising from future changes to its specifications and product descriptions. No license, express or implied, by estoppel or otherwise, to any intellectual property rights is granted by this document.

THESE MATERIALS ARE PROVIDED "AS IS" WITHOUT WARRANTY OF ANY KIND, EITHER EXPRESS OR IMPLIED, RELATING TO SALE AND/OR USE OF MACOM PRODUCTS INCLUDING LIABILITY OR WARRANTIES RELATING TO FITNESS FOR A PARTICULAR PURPOSE, CONSEQUENTIAL OR INCIDENTAL DAMAGES, MERCHANTABILITY, OR INFRINGEMENT OF ANY PATENT, COPYRIGHT OR OTHER INTELLECTUAL PROPERTY RIGHT. MACOM FURTHER DOES NOT WARRANT THE ACCURACY OR COMPLETENESS OF THE INFORMATION, TEXT, GRAPHICS OR OTHER ITEMS CONTAINED WITHIN THESE MATERIALS. MACOM SHALL NOT BE LIABLE FOR ANY SPECIAL, INDIRECT, INCIDENTAL, OR CONSEQUENTIAL DAMAGES, INCLUDING WITHOUT LIMITATION, LOST REVENUES OR LOST PROFITS, WHICH MAY RESULT FROM THE USE OF THESE MATERIALS.

MACOM products are not intended for use in medical, lifesaving or life sustaining applications. MACOM customers using or selling MACOM products for use in such applications do so at their own risk and agree to fully indemnify MACOM for any damages resulting from such improper use or sale.