

Tous droits strictement réservés. Reproduction ou communication o des liens interdite sous quelque forme que ce soit sans autorisation écrite du propriétaire. Propriete de c FCI. Droits de reproduction FCI.

All rights strictly reserved. Reproduction or issue to third parties in any form, whenever is not permitted without written authority from the proprietor. Property of FCI. Copyright FCI.

PRODUCT NO.	ROWS	POWER				SIGNAL			POWER					E1		
		E2	P9	P8	P7	P6	4	3	2	1	P5	P4	P3		P2	P1
51897-002	D C B A		PC	PC	PC	PC	F	F	F	F	X	X	PH	PH	PG	

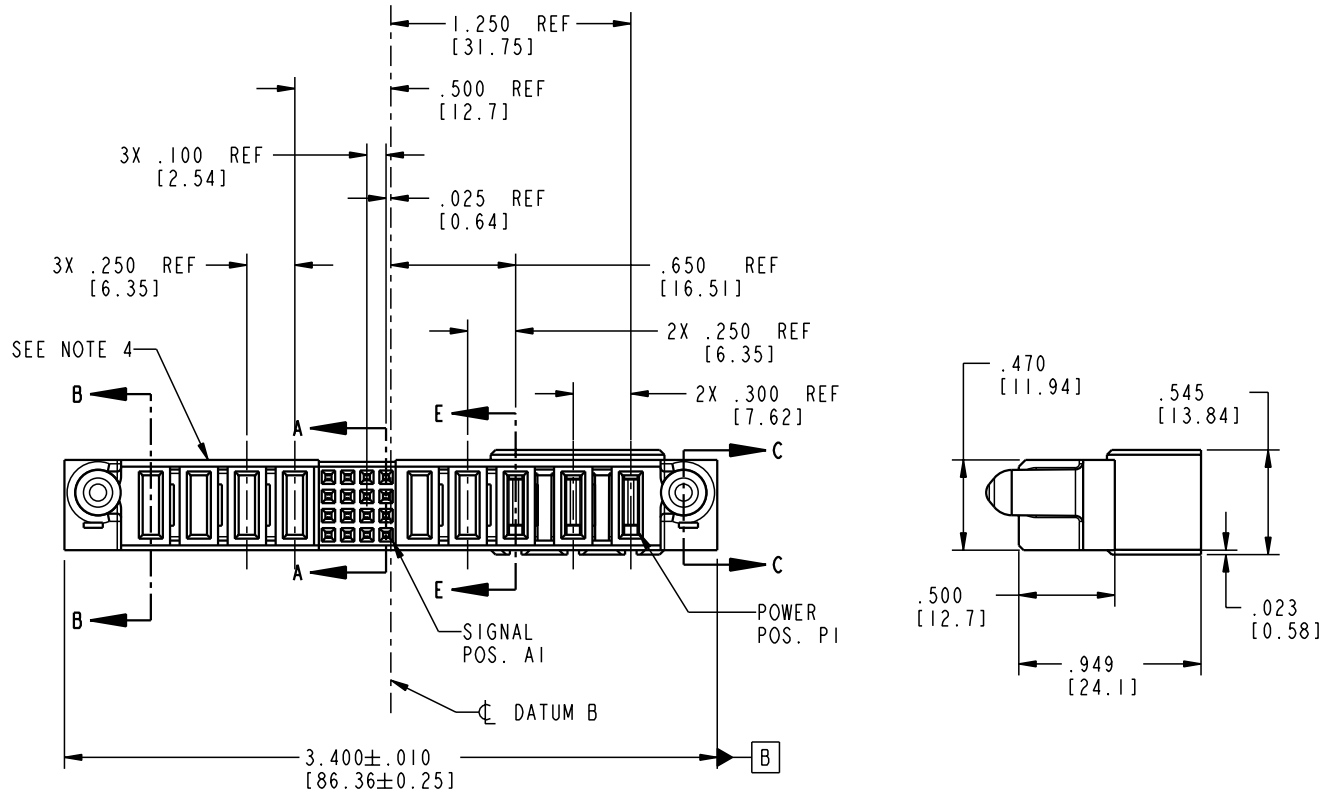

CODE	DIM "M" MATING LENGTH	CONTACT TYPE
F	N/A [N/A]	SIGNAL
PC	.042 [1.07]	POWER
PG	.042 [1.07]	POWER
PH	.092 [2.34]	POWER
X	OMITTED	OMITTED

mat'l code				SEE NOTE 2		tolerances unless otherwise specified		CUSTOMER		 www.fciconnect.com	
ltr	ecn no.	dr	date	linear	.XX±.01/0.X±0.3		COPY		 title 3ACP + 2P + 16S + 4P VERT PRESS FIT RECEPT CABLE PORT		
A	V21382	CGD	08/26/02		.XXX±.005/0.XXX±0.13		projection				
B	V21459	TAB	09/17/02		.XXX±.0020/0.XXX±0.051		 product family PwrBlade code 213				
C	V21648	CGD	10/22/02	angles	0° ± 2°		scale 1:1		size 51897-002 sheet 1 of 5		
sheet index		revision sheet		C	C	C	C	C	cage code 22526		

Pro/E

PDM: Rev:C

STATUS: Released

Printed: Dec 20, 2010

Tous droits strictement réservés. Reproduction ou communication o des tiers interdite sous quelque forme que ce soit sans autorisation écrite du propriétaire. Propriete de c FCI. Droits de reproduction FCI.

All rights strictly reserved. Reproduction or issue to third parties in any form whatever is not permitted without written authority from the proprietor. Property of FCI. Copyright FCI.

PRODUCT NUMBER
51897-002

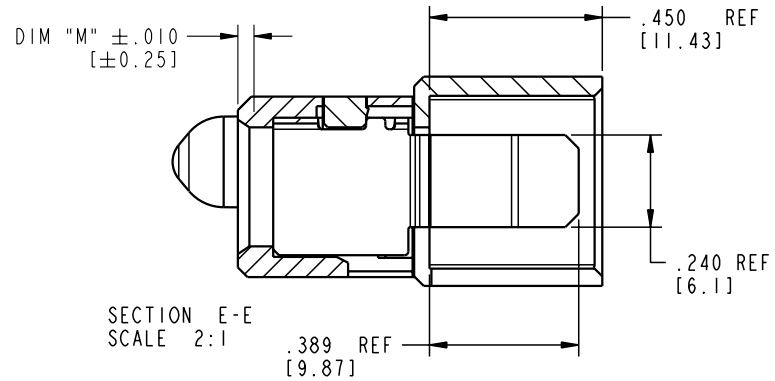
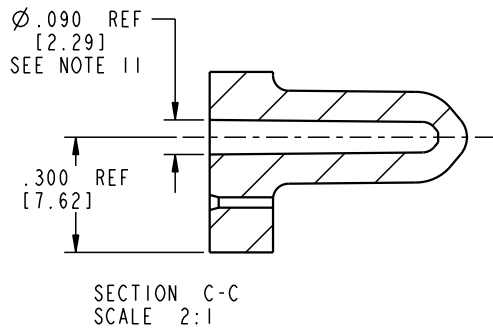
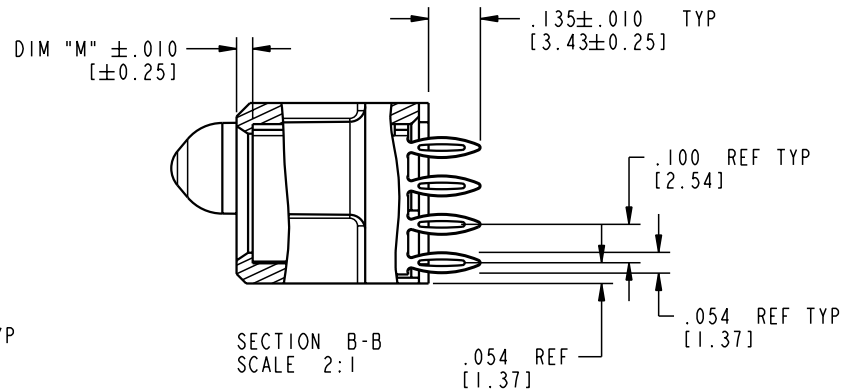
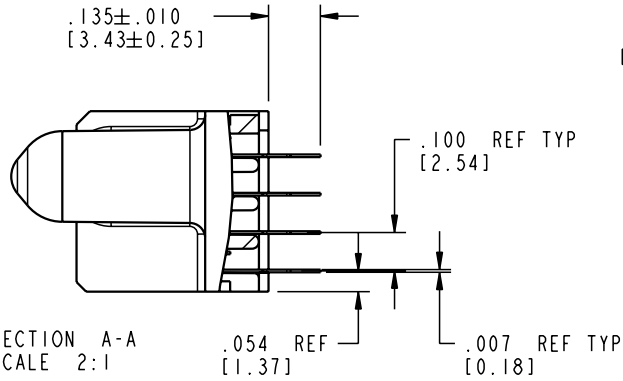

mat'l code				SEE NOTE 2		tolerances unless otherwise specified		CUSTOMER		 www.fciconnect.com	
ltr	ecn no.	dr	date	linear	.XX±.01/0.X±0.3		COPY		title 3ACP + 2P + 16S + 4P VERT PRESS FIT RECEPT CABLE PORT		
C					.XXX±.005/0.XX±0.13		projection				
					angles	.XXX±.0020/0.XXX±0.051		 INCH/MM		product family PwrBlade code 213	
						0° ± 2°		scale 1:1		size 51897-002 sheet 2 of 5	
sheet index		revision sheet		dr C. DAILY 08/26/02		enr M. MOSTOLLER 08/26/02		chr M. MOSTOLLER 08/26/02		appd M. MOSTOLLER 08/26/02	

Pro/E

cage code 22526

PDM: Rev:C

STATUS: Released

Printed: Dec 20, 2010

Tous droits strictement réservés. Reproduction ou communication o des tiers interdite sous quelque forme que ce soit sans autorisation écrite du propriétaire. Propriete de c FCI. Droits de reproduction FCI.

All rights strictly reserved. Reproduction or issue to third parties in any form whatever is not permitted without written authority from the proprietor. Property of FCI. Copyright FCI.

PRODUCT NUMBER
51897-002

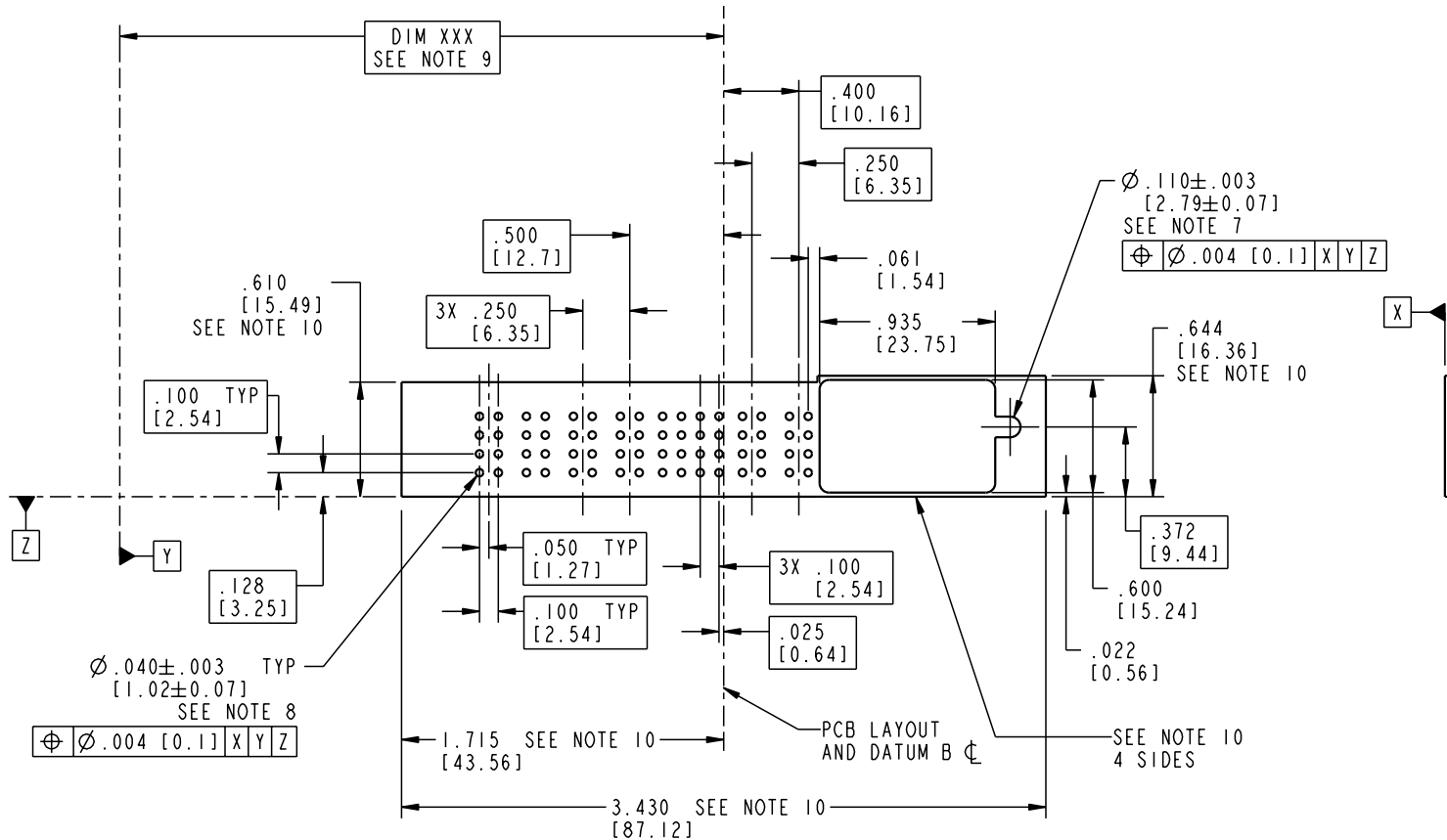

mat'l code				SEE NOTE 2		tolerances unless otherwise specified		CUSTOMER		 www.fciconnect.com	
ltr	ecn no.	dr	date	linear	.XX±.01/0.X±0.3	projection	COPY		title		
C				linear	.XXX±.005/0.XX±0.13				3ACP + 2P + 16S + 4P		
				angles	.XXX±.0020/0.XXX±0.051				VERT PRESS FIT RECEPT CABLE PORT		
				dr	C. DAILY 08/26/02	INCH/MM	product family		PwrBlade		code
				enr	M. MOSTOLLER 08/26/02	scale	size		dwg no		213
				chr	M. MOSTOLLER 08/26/02	1:1	A		51897-002		sheet
				appd	M. MOSTOLLER 08/26/02						3 of 5
sheet index	revision sheet										

cage code 22526

Pro/E

PDM: Rev:C

STATUS: Released

Printed: Dec 20, 2010

Tous droits strictement réservés. Reproduction ou communication o des tiers interdite sous quelque forme que ce soit sans autorisation écrite du propriétaire. Propriete de c FCI. Droits de reproduction FCI.



All rights strictly reserved. Reproduction or issue to third parties in any form, whatever is not permitted without written authority from the proprietor. Property of FCI. Copyright FCI.

PRODUCT NUMBER
51897-002

NOTES:

1. DIMENSIONS AND TOLERANCES ARE IN ACCORDANCE WITH ASME Y14.5M, 1994 UNLESS OTHERWISE SPECIFIED.

CONNECTOR NOTES:

2 HOUSING MATERIAL: UL 94 V-0 GLASS FILLED
HIGH-TEMP THERMOPLASTIC
POWER CONTACT MATERIAL: COPPER ALLOY
SIGNAL PIN MATERIAL: COPPER ALLOY

3. PLATING:
SIGNAL PINS: 30u"/0.76um Au OVER 50u"/1.27um Ni
POWER CONTACTS: 50u"/1.27um Ni UNDER ALL WITH 30u"/0.76um Au ON CONTACT AREA AND SnPb ON PCB INTERFACE

4 MANUFACTURER'S NAME, P/N, AND DATE CODE TO APPEAR ON THIS SURFACE.

5. PRODUCT SPECIFICATION GS-12-149.
APPLICATION SPECIFICATION BUS-20-067.

PCB NOTES:

6. ALL HOLE DIAMETERS ARE FINISHED HOLE SIZE.
7. MOUNTING HOLES, WHERE APPLICABLE, ARE UNPLATED.

8 $\varnothing .0453 \pm .0010$ [1.151 \pm 0.025] DRILLED HOLES PLATED WITH .0003 [0.008] MIN SnPb OVER .001 [0.03] TO .003 [0.08] Cu PLATING TO ACHIEVE $\varnothing .040 \pm .003$ [1.02 \pm .07] HOLE.

9 "DIM XXX" TO BE DETERMINED BY THE CUSTOMER.

10 CONNECTOR KEEP-OUT ZONE.

11 RECOMMENDED RETENTION TO PCB

$\varnothing .110$ [2.79] THRU HOLE FOR M2.5 SOCKET HEAD CAP SCREW
MAX. HEAD $\varnothing 4.5$ mm [1.77] RECOMMENDED SCREW LENGTH 12mm [1.472] + PCB THICKNESS.
RECOMMENDED SCREW SEATING TO PCB TORQUE: 2-5 lbf-in (2300-5760 gf-cm).

mat'l code				SEE NOTE 2		tolerances unless otherwise specified		CUSTOMER		 www.fciconnect.com	
ltr	ecn no.	dr	date	linear	.XX±.01/0.X±0.3		COPY		title 3ACP + 2P + 16S + 4P VERT PRESS FIT RECEPT CABLE PORT		
C					.XXX±.005/0.XX±0.13		projection				
					angles	.XXX±.0020/0.XXX±0.051		 INCH/MM			
				dr	C. DAILY	08/26/02	scale		product family PwrBlade		code
				engr	M. MOSTOLLER	08/26/02	1:1		size	dwg no	sheet
				chr	M. MOSTOLLER	08/26/02			A	51897-002	213
				appd	M. MOSTOLLER	08/26/02					4 of 5
sheet index		revision sheet									

1 | 2

Pro/E

3 |

cage code 22526

4

PDM: Rev:C

STATUS: Released

Printed: Dec 20, 2010

Tous droits strictement reserves. Reproduction ou communication a des tiers interdite sous quelque forme que ce soit sans autorisation ecrite du proprietaire. Propriete de c FCI. Droits de reproduction FCI.

All rights strictly reserved. Reproduction or issue to third parties in any form whatever is not permitted without written authority from the proprietor. Property of FCI. Copyright FCI.

PRODUCT NUMBER
51897-002

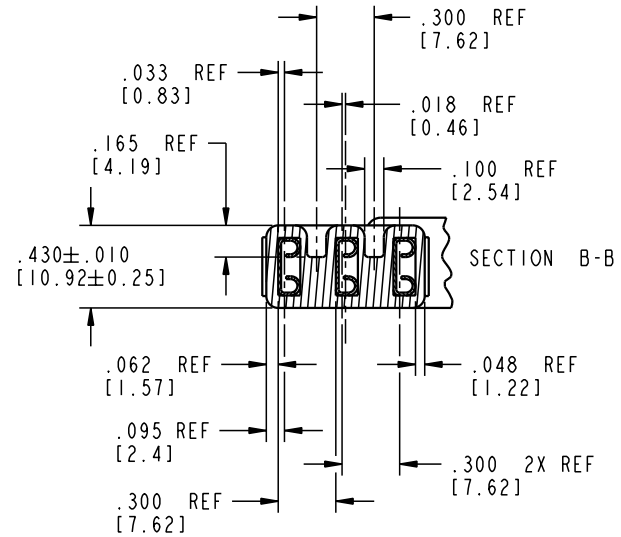
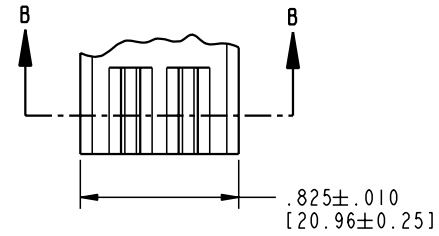
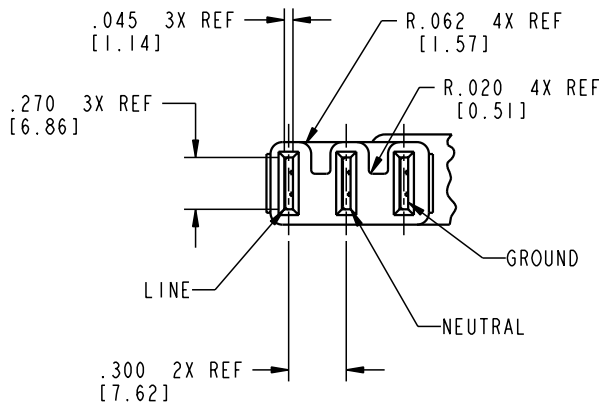

MATING CABLE PLUG (FOR REFERENCE ONLY)

mat'l code				SEE NOTE 2		tolerances unless otherwise specified		CUSTOMER		 www.fciconnect.com	
ltr	ecn no.	dr	date	linear	.XX±.01/0.X±0.3		COPY		title 3ACP + 2P + 16S + 4P VERT PRESS FIT RECEPT CABLE PORT		
C					.XXX±.005/0.XX±0.13		projection				
					.XXX±.0020/0.XXX±0.051						
				angles	0° ± 2°		INCH/MM		product family PwrBlade		code 213
				dr	C. DAILY	08/26/02	scale 1:1		size		sheet 5 of 5
				enr	M. MOSTOLLER	08/26/02	A		dwg no 51897-002		
				chr	M. MOSTOLLER	08/26/02					
				appd	M. MOSTOLLER	08/26/02					
sheet index	revision sheet										

Pro/E

cage code 22526

PDM: Rev:C

STATUS: Released

Printed: Dec 20, 2010