

REVISIONS

P	LTR	DESCRIPTION	DATE	DWN	APVD
	A	INITIAL RELEASE	02APR2021	BS	CB

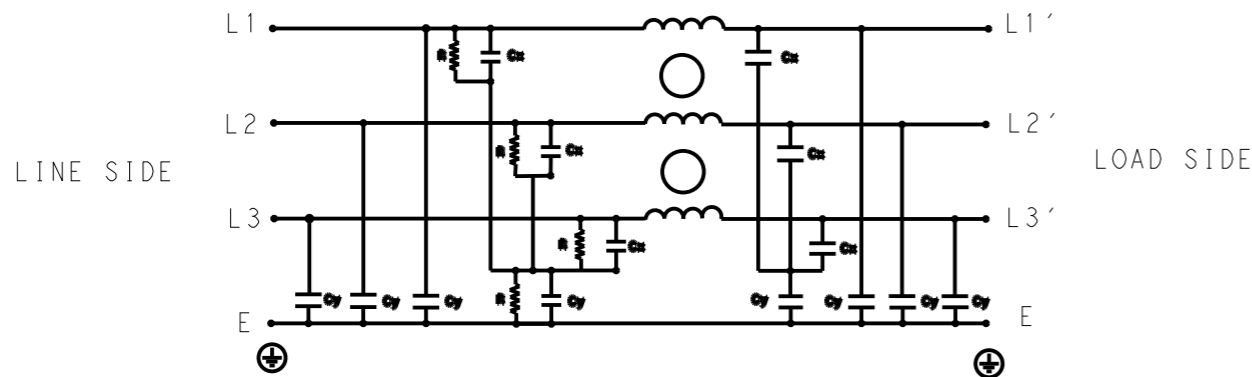

SCHEMATIC

SAFETY ORGANIZATIONS

THIS FILTER WILL BE FORMALLY RECOGNIZED, CERTIFIED OR APPROVED BY THE LISTED AGENCY. THEREFORE, ALL TEST/REQUIREMENTS SPECIFIED IN THE LATEST REVISION OF THE FOLLOWING AGENCY STANDARDS WILL BE MET:

UL APPROVED 10A 520V 50Hz/60Hz 40°C
 CSA PENDING 10A 520V 50Hz/60Hz 40°C

OPERATING SPECIFICATION

LINE CURRENT/VOLTAGE: 10A, 520VAC
LINE FREQUENCY: 50/60Hz

MAXIMUM LEAKAGE CURRENT: 18mA @ 230VAC, 50Hz

OPERATING AMBIENT TEMPERATURE RANGE @ RATED CURRENT: -25°C TO +40°C

IN AN AMBIENT, T_a, HIGHER THAN 40°C, THE MAXIMUM OPERATING CURRENT, I_o, IS AS FOLLOWS:

$$I_o = I_r \sqrt{\frac{85 - T_a}{45}}$$

RELIABILITY SPECIFICATIONS

STORAGE TEMPERATURE: -40°C TO +85°C
HUMIDITY: 21 DAYS @ 40°C AND 95% RH

TEST SPECIFICATIONS

INDUCTANCE, NOMINAL: 8mH

CAPACITANCE @ 1kHz

LINE TO GROUND, NOMINAL: 1.1µF
LINE TO LINE, NOMINAL: 1µF

DISCHARGE RESISTOR

L/G I.R. 1MΩ 1W
 L/L I.R. 2MΩ 1W
 L/N I.R. XXX
 N/G I.R. XXX

IR (NO DISCHARGE RESISTOR) 20°C, 50% RH AND 100VDC, MIN: 6MΩ

RECOMMENDED RECEIVING INSPECITON HIPOI

LINE TO GROUND FOR 1 MINUTE: 2856VDC
LINE TO LINE FOR 1 MINUTE: 2236VDC

FILTER APPROVAL

THE BEST WAY TO SELECT AND QUALIFY A FILTER IS FOR YOUR ENGINEERING TO TEST THE UNIT IN YOUR EQUIPMENT.

TYPICAL INSERTION LOSS
COMMON MODE 50/50Ω; DIFFERENTIAL MODE 50/50Ω

MHz	0.01	0.05	0.15	0.5	1	3	5	10	30
CM	65	64	61	55	51	42	38	33	27
DM	20	23	36	61	49	38	34	29	25

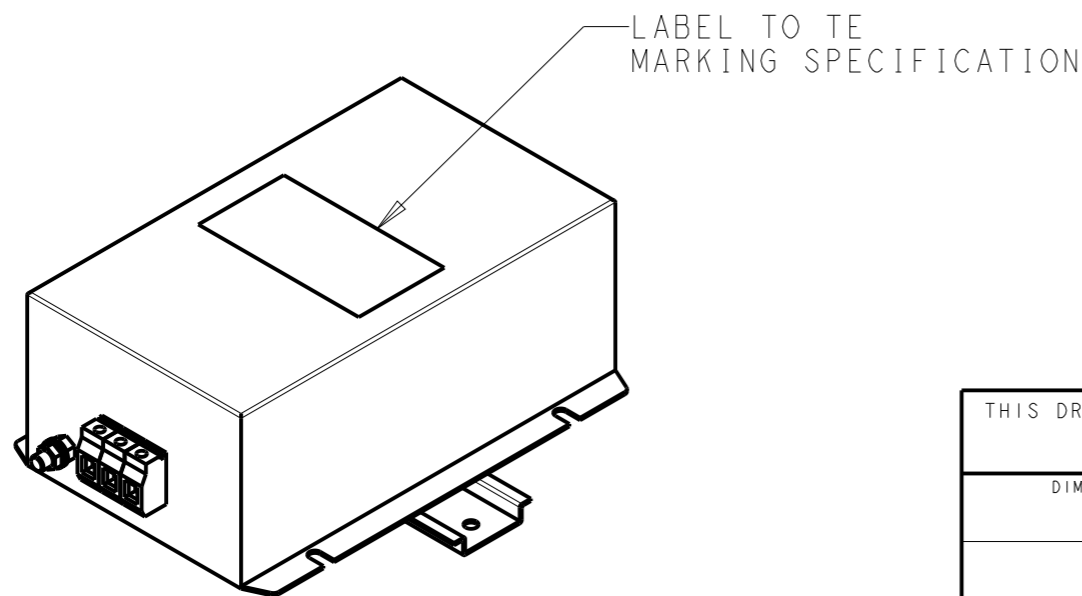

THIS DRAWING IS A CONTROLLED DOCUMENT.		DWN 05APR2021 BAPAT SAHAS		
DIMENSIONS: mm		CHK 05APR2021 CHRIS BOLLE		
TOLERANCES UNLESS OTHERWISE SPECIFIED:		APVD 05APR2021 CHRIS BOLLE	NAME POWER LINE FILTER FOR DIN 35 RAIL INSTALLATION 10KEMS10BFPDHM	
0 PLC ±-		PRODUCT SPEC	SIZE	
1 PLC ±0.5		APPLICATION SPEC	CAGE CODE	
2 PLC ±0.40		WEIGHT	DRAWING NO	
3 PLC ±0.130		CUSTOMER DRAWING	RESTRICTED TO	
4 PLC ±0.0500		SCALE 2:5	SHEET 1 OF 2	
ANGLES ±-		REV A		
MATERIAL		A300779 C-9-1609967-3		
FINISH				

© 2021 TE Connectivity. All Rights Reserved.

NOTE 1 GROUND CONNECTION:
 FOR ELECTRICAL SAFETY AND FILTER PERFORMANCE
 UNIT MUST HAVE A GOOD GROUND CONNECTION.
 TORQUE OUTER TERMINAL SCREWS: 0.5Nm / 4.5 in.lbs
 TORQUE GROUND NUTS: 2.5-3Nm

NOTE 2 INPUT OUTPUT CONNECTION TERMINAL
 AWG SIZE: 26-12 AWG
 WIRE SECTION: 4 mm²
 THREADED BOLT SIZE FOR GROUND: M6

NOTE 3 SUPPLIED WITH DIN RAIL BRACKET

NOTE 4 DRAWINGS SHOWS DIN RAIL FOR
 REFERENCE ONLY

REVISIONS					
P	LTR	DESCRIPTION	DATE	DWN	APVD
		SEE SHEET 1			

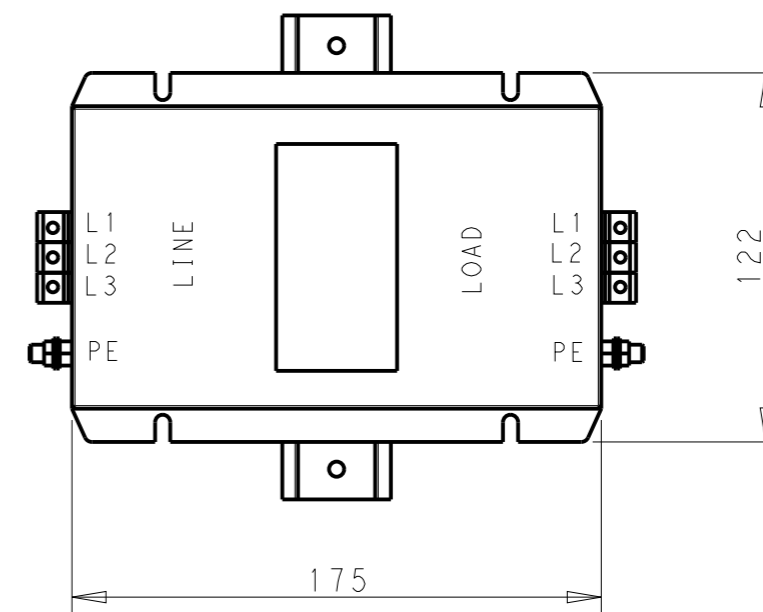
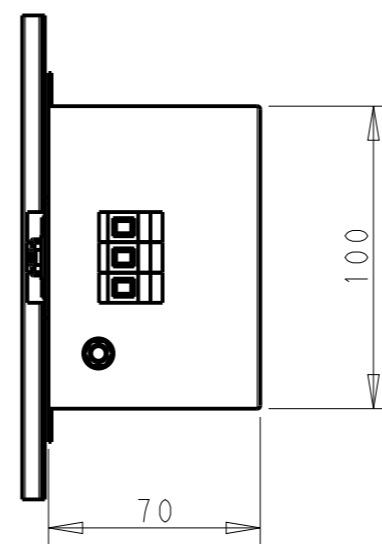
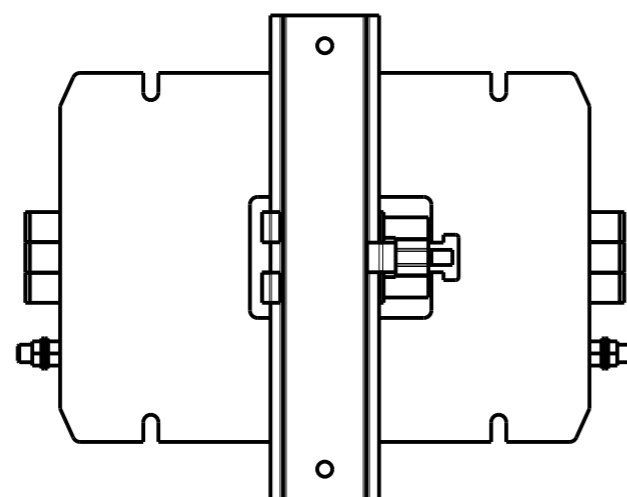

DIN RAIL CHANNEL DIN 35 BRACKET

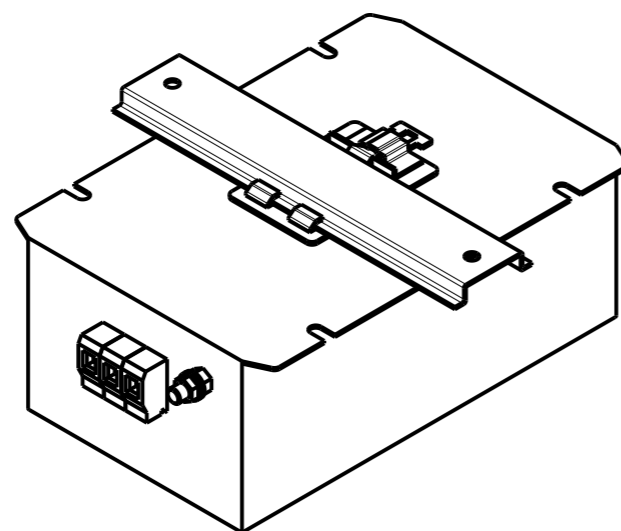
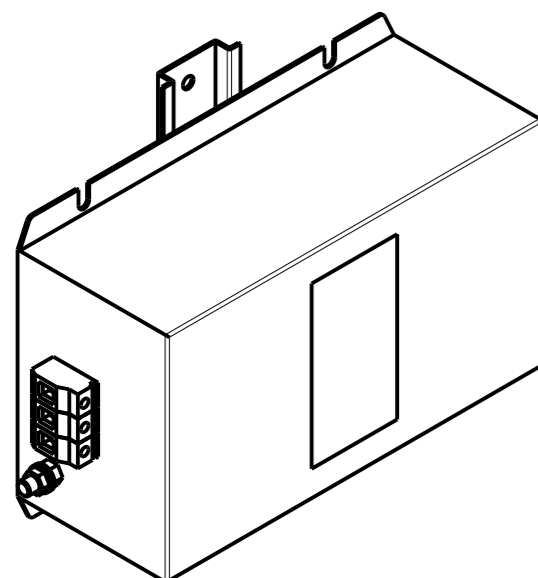

THIS DRAWING IS A CONTROLLED DOCUMENT.

DIMENSIONS:	TOLERANCES UNLESS OTHERWISE SPECIFIED:
mm	
	0 PLC ±-
	1 PLC ±0.5
	2 PLC ±0.40
	3 PLC ±0.130
	4 PLC ±0.0500
	ANGLES ±-

MATERIAL	FINISH
-	-
-	-

DWN	05APR2021
BAPAT SAHAS	
CHK	05APR2021
CHRIS BOLLE	
APVD	05APR2021
CHRIS BOLLE	

PRODUCT SPEC	-
APPLICATION SPEC	-
WEIGHT	-
CUSTOMER DRAWING	

TE TE Connectivity

NAME
 POWER LINE FILTER FOR
 DIN 35 RAIL INSTALLATION
 10KEMS10BFPDHM

SIZE	CAGE CODE	DRAWING NO	RESTRICTED TO
A3	00779	C-9-1609967-3	-
SCALE	SHEET	OF	REV
2:5	2	2	A