

LED PARAMETER	FORWARD CURRENT	FORWARD VOLTAGE @ 20mA	LUMINOUS INTENSITY
UNITS	mA	V	mcd
GREEN	20	2.2 - 2.7	130

NOTE:

- ALL DIMENSIONS IN MM [INCH]
- GENERAL TOLERANCE: X.X = ± 0.4
X.XX = ± 0.25
- TERMINAL NUMBERS FOR REF ONLY
- CIRCUIT: SPST OFF - (ON) MOMENTARY
- CONTACT MATERIAL: GOLD OVER SILVER
- RATING: 500mA @ 48 VAC
200mA @ 50 VDC
200mA @ 250 VAC
- ELECTRIC LIFE: 500,000 CYCLES AT FULL LOAD
- CONTACT RESISTANCE: 50 MILLIOHM MAX. (INITIAL)
- INSULATION RESISTANCE: 1,000 MEGA-OHM MIN. @ 500VDC
- DIELECTRIC STRENGTH: 1,500 VAC FOR 1 MINUTE
- OPERATING FORCE: 350gf +/- 150gf
- OPERATING TEMPERATURE: -30°C to +85°C
- CONTACT BOUNCE: 10ms MAX.
- TRAVEL: 1.5 ± 0.25 mm
- PANEL THICKNESS RANGE: 1.5 - 4.0mm
- ▲ DENOTES CRITICAL PARAMETER.
- 2011/65/EU (ROHS) COMPLIANT
- MAX TORQUE APPLIED TO MOUNTING NUT: 1.5Nm
- HARDWARE INCLUDED:
 - T081101 LOCK WASHER (1)
 - T081102 HEX NUT (1)
 - T081103 O-RING (1)
- SEAL RATING: IP67 AT THE FRONT PANEL

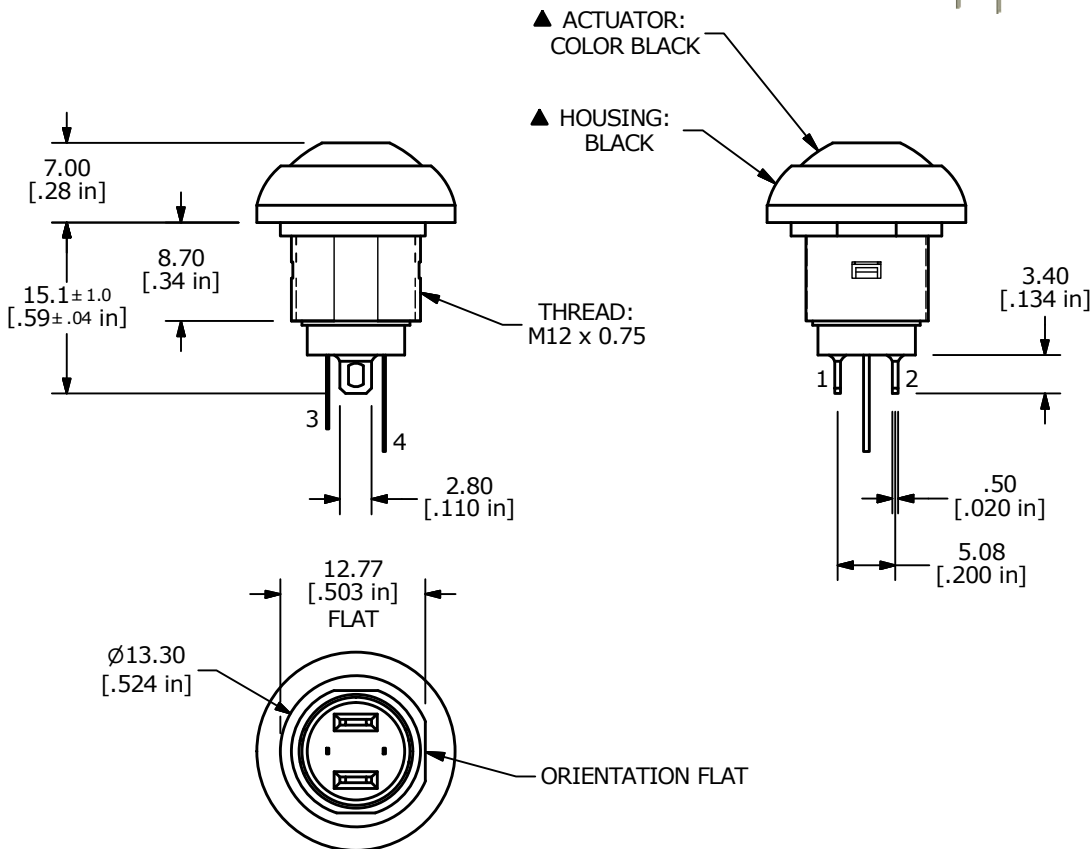

REV	PCR NO	DESCRIPTION	DATE	BY
D	23160	correct Function callout	1/11/18	MW
C	22473	UPDATED LED SPECIFICATION CHART	8/30/16	MJR
B	21599	CHANGE SEAL RATING FROM IP65 TO IP67	10/1/14	EBP

THE INFORMATION CONTAINED IN THIS DOCUMENT IS PROPRIETARY TO E-SWITCH AND IS NOT TO BE COPIED OR TRANSFERRED

E-SWITCH®

TITLE RP8300B2M1CEBLKBLKGRN

SCALE	DATE	DR	DWG	REV
3:2	5/4/2011	BMA	ST083005	D