

IS31FL3746A

24-RGB MATRIX LED DRIVER

Advance Information
July 2018

GENERAL DESCRIPTION

The IS31FL3746A is a general purpose 18×n (n=1~4) LED Matrix programmed via 1MHz I2C compatible interface. Each LED can be dimmed individually with 8-bit PWM data and 8-bit DC scaling (Color Calibration) data which allowing 256 steps of linear PWM dimming and 256 steps of DC current adjustable level.

Additionally each LED open and short state can be detected, IS31FL3746A store the open or short information in Open-Short Registers. The Open-Short Registers allowing MCU to read out via I2C compatible interface. Inform MCU whether there are LEDs open or short and the locations of open or short LEDs.

The IS31FL3746A operates from 2.7V to 5.5V and features a very low shutdown and operational current.

IS31FL3746A is available in QFN-32 (4mm×4mm) package. It operates from 2.7V to 5.5V over the temperature range of -40°C to +125°C.

FEATURES

- Supply voltage range: 2.7V to 5.5V
- 18 current sinks
- Support 18×n (n=1~4) LED matrix configurations
- Individual 256 PWM control steps
- Individual 256 DC current steps
- Global 256 current steps
- SDB rising edge reset I2C module
- 24kHz PWM frequency
- 1MHz I2C-compatible interface
- State lookup registers
- Individual open and short error detect function
- De-Ghost
- QFN-32 (4mm×4mm) package

APPLICATIONS

- Mobile phones and other hand-held devices for LED display
- Gaming device (Mouse, Mouse MAT etc.)
- IOT device (AI speaker etc.)

TYPICAL APPLICATION CIRCUIT

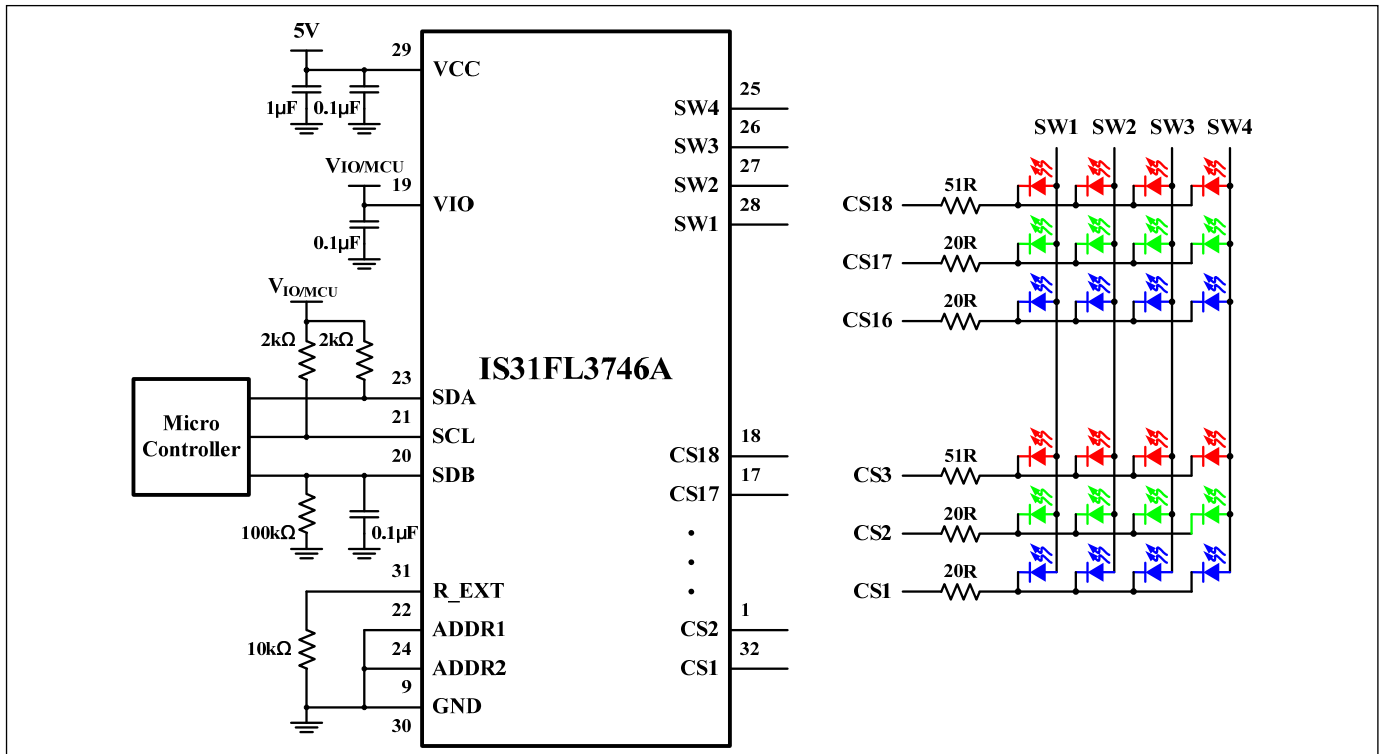
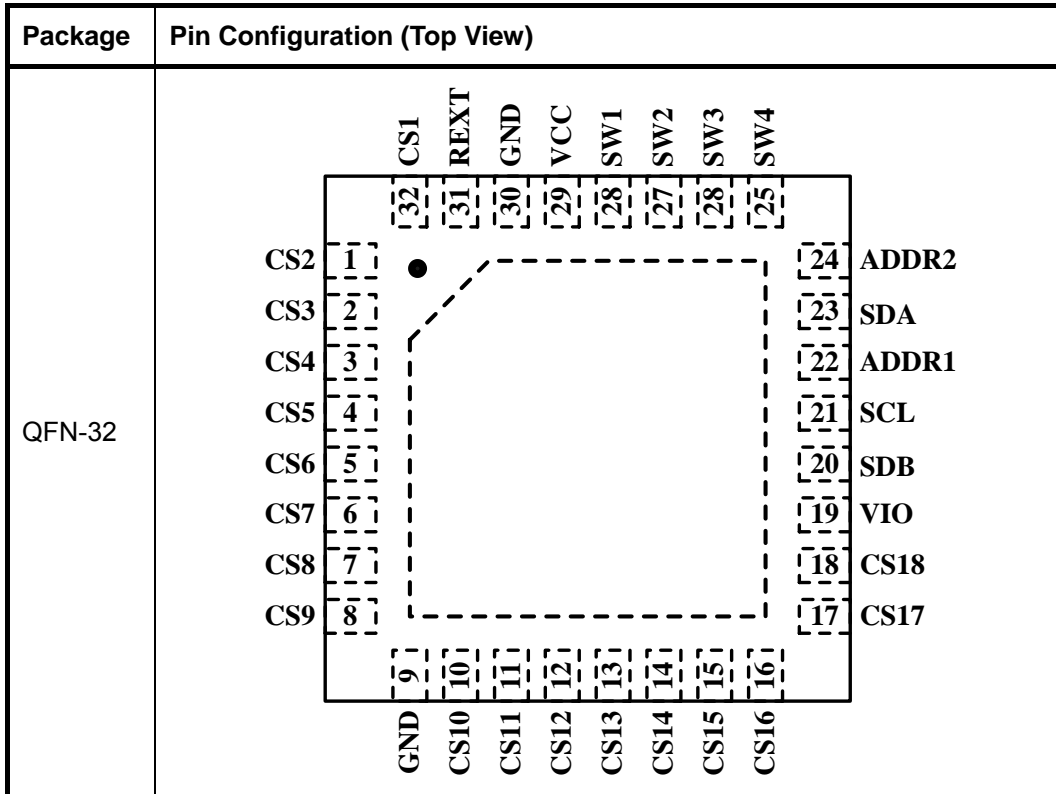

Figure 1 Typical Application Circuit: 18×4, 24 RGBs

IS31FL3746A

PIN CONFIGURATION



PIN DESCRIPTION

No.	Pin	Description
28~25	SW1~SW4	Power SW.
18~10,8~1,32	CS18~CS1	Current sink pin for LED matrix.
9,30	GND	Ground.
19	VIO	Input logic reference voltage, can't be floated.
20	SDB	Shutdown pin.
21	SCL	I2C compatible serial clock.
22	ADDR1	I2C address select.
23	SDA	I2C compatible serial data.
24	ADDR2	I2C address select.
29	VCC	Power for current source SW and analog.
31	R_EXT	Set the maximum IOUT current.
	Thermal Pad	Connect to GND.



IS31FL3746A

ORDERING INFORMATION

Industrial Range: -40°C to +125°C

Order Part No.	Package	QTY/Reel
IS31FL3746A-QFLS4-TR	QFN-32, Lead-free	2500

Copyright © 2018 Integrated Silicon Solution, Inc. All rights reserved. ISSI reserves the right to make changes to this specification and its products at any time without notice. ISSI assumes no liability arising out of the application or use of any information, products or services described herein. Customers are advised to obtain the latest version of this device specification before relying on any published information and before placing orders for products. Integrated Silicon Solution, Inc. does not recommend the use of any of its products in life support applications where the failure or malfunction of the product can reasonably be expected to cause failure of the life support system or to significantly affect its safety or effectiveness. Products are not authorized for use in such applications unless Integrated Silicon Solution, Inc. receives written assurance to its satisfaction, that:

- a.) the risk of injury or damage has been minimized;
- b.) the user assume all such risks; and
- c.) potential liability of Integrated Silicon Solution, Inc is adequately protected under the circumstances