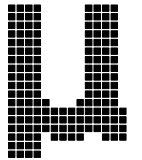

Embedded low power radio modem **MU-4****MU-4 RS232C Interface Board****MU4-RS2IF**

Operation Guide

Version 1.0 (Sep. 2020)

CIRCUIT DESIGN, INC.,7557-1 Hotaka, Azumino-city
Nagano 399-8303 JAPAN

Tel: +81+(0263)-82-1024

Fax: +81+(0263)-82-1016

E-mail: info@circuitdesign.jpWeb site: <https://www.cdt21.com/>

Contents

Chapter 1 The MU4-RS2IF	2
1.1 Outline	2
1.2 System Requirements	3
1.3 Product Name and Part Number	4
1.4 Board and contents	4
Chapter 2 The MU4-RS2 (MU-4 + MU4-RS2IF)	5
2.1 Part Names and Functions	5
2.2 Block Diagram	6
2.3 Main Specifications	7
2.4 Channel Table	7
2.5 External dimensions	8
2.6 Circuit Diagram	9
Chapter 3 How to Use the MU4-RS2	10
3.1 System Configuration Example	10
3.2 Resetting	11
3.3 Initializing	11
3.4 Connection example	11
Chapter 4 How to Design a User System	12
4.1 Embedding the Product	12
4.2 The antenna	13
4.3 Regulatory Compliance	13
4.4 Cautions	13
Chapter 5 How to Develop a Program	14

Chapter 1 The MU4-RS2IF

1.1 Outline

The MU-4 RS232C interface board, MU4-RS2IF is a development board for planning radio system with an RS232C interface connection function that uses the embedded low power radio modem MU-4. Purchasing the board enables you to begin evaluating communication with the MU-4 immediately.

The board with MU-4 can be controlled using simple dedicated commands, so that the developer can concentrate on designing the protocols for transmitting and receiving data, without needing to be aware of control of the radio component. Since the control program created by the user accesses the host COM port, users can apply their fund of knowledge of RS232C technology.

■ 1.1.1 The MU4-RS2

In this operation guide, for the sake of convenience, the MU-4 RS232C interface board, MU4-RS2IF with the embedded low power radio modem MU-4 mounted on it is referred to as the MU4-RS2. Before using the board, mount the MU-4 on the MU4-RS2IF. When mounting the MU-4, observe the following cautions, and carry out the soldering carefully.



MU-4-434

MU4-RS2IF

MU4-RS2



Cautions for soldering

- To prevent damage to the connectors, solder the joints quickly.
- Avoid connection defects.
- In order to prevent damage to the MU-4 and the MU4-RS2IF from static electricity, earth yourself before starting work.
- Do not cause short circuits by dripping solder on the board.

🔑 Important

The development board does not include module MU-4. Please make sure to order it if needed.

It is not possible simply to replace communication using existing RS232C system equipment connected with a cable, with MU4-RS2 wireless communication. The hardware and software must be designed specifically for the MU-4.

■ 1.1.2 Explanation of terminology

The meaning of the terminology used in this Operation Guide is as follows.

1. The **“Evaluation program and driver”** is the zip file that is available from the Circuit Design website, that contains the setup program, Operation Guide and so on.
The program is located on MU-4 documents page.
2. The **“Evaluation Program”** is a program for evaluation of the MU-2-R and series of products, called the MU-2-R Evaluation Software Program MU2-ESP. After installation it is found inside the “Circuit Design” folder that appears on the desktop of your PC. MU-4 that is compatible with commands and interface, can also use this program.

■ 1.1.3 Features

- ◆ Circuit diagrams for making user systems are publicly available.
- ◆ Compact size (47 × 71 × 18 mm) fits in a small housing.
- ◆ Features of the MU2-ESP evaluation program;
 1. You can issue all commands for controlling the interface board with module.
 2. There is a test program for checking the communication performance of the interface board with module.
 3. There is an air monitor function for checking the status of radio waves in the field.

■ 1.1.4 Applications

- ◆ Serial data transmission
Energy monitoring, data monitoring devices, handy terminals, barcode readers
- ◆ Telecontrol
Remote control for construction machinery, display devices, motor control, lifters
Remote control of FA equipment
- ◆ Telemetry
Water level monitors for rivers and dams, temperature and humidity gauges, rain gauges, pressure gauges, voltmeters, ammeters

1.2 System Requirements

Systems used with MU4-RS2IF must meet the following conditions.

1. OS: Windows 8 and 10
2. Hard disk capacity: 30 MB or more
3. Memory: 64 MB or more

1.3 Product Name and Part Number

Product name: MU-4 RS232C interface board

Part number: MU4-RS2IF

1.4 Board and contents

The board and contents are as follows. First, please check that you have all the items.

■ 1.4.1 Accessories

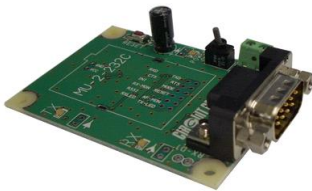

MU4-RS2IF x 1



Screw(M2.6 x 6mm) x 4
Spacer(10mm) x 4



Battery holder x 1

- | | |
|--|---|
| 1. MU-4 RS232C interface board MU4-RS2IF | 1 |
| 2. Battery holder | 1 |
| 3. Spacers (used as legs) 10 mm | 4 |
| 4. Screws for spacers M 2.6 x 6 mm | 4 |

Chapter 2 The MU4-RS2 (MU-4 + MU4-RS2IF)

2.1 Part Names and Functions

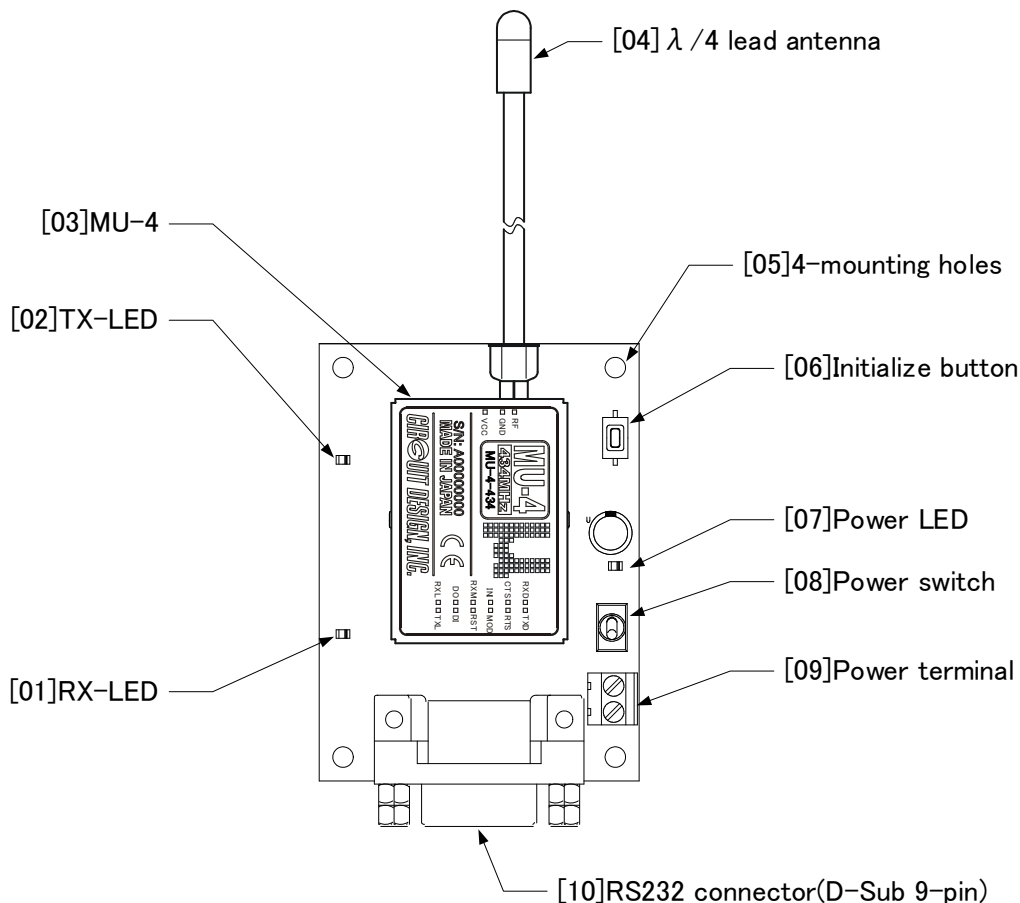

[01] RX-LED: On when data is received.

[02] TX-LED: On when data is transmitted.

[03] MU-4: A low power serial data transmission modem.

[04] $\lambda/4$ Lead antenna: A $\lambda/4$ long lead antenna (ANT-LEA-01, ANT-RIG-01-R).

[05] Mounting holes: 3 Φ holes for mounting

[06] Initialize button: Resets the MU-4 mounted on the MU4-RS2IF to the factory default settings. Follow the procedure below.

1. Turn on the power while pressing the initialize button.
2. Turn off the power and on once again after a while (approx. 5 seconds).

[07] Power LED: The LED comes on when the power switch is turned on.

[08] Power switch: A power switch. Check that the power terminal is connected before turning it on.

[09] Power terminal: The connector for the power supply. Connect a 9 V battery with the battery snap provided.

* If you connect to a power supply other than a 9 V dry battery, ensure that it is DC +3.2 V to DC +12 V. Be sure to connect the power supply with the correct polarity. Add a noise filter to the power line.

[10] RS232C connector (D-Sub 9-pin socket): A D-Sub 9-pin socket for RS232C. Connect the RS232C straight cable provided. You can also supply power from the RS232C connector pin No.1. In this case, take the voltage drop (approx. 0.6 V) due to the diodes into consideration. For details, refer to the circuit diagram.

2.2 Block Diagram

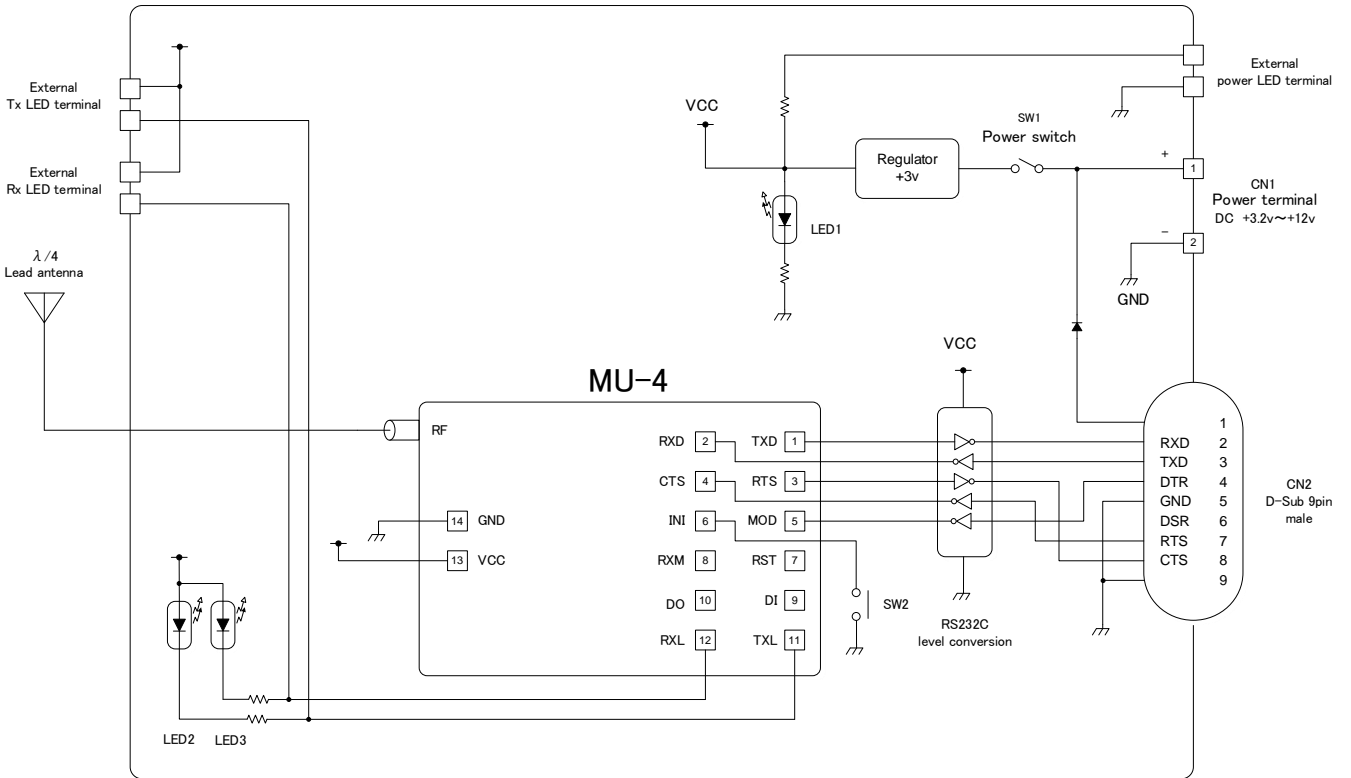

2.3 Main Specifications

■ 2.3.1 General specifications

Parameter	Specification	Unit	Remark
Supply voltage	DC +3.2 to +12 V	V	
Consumption current	Transmitting: 48 / Receiving: 28	mA	
Operating temperature	-20 to +65	°C	The operation range varies with the temperature conditions.
LED indicator	Tx, Rx, Power		
Power connector	Terminal block (2 pin)		
Switch	Power, initialize		
External dimensions	47 × 71 × 18 (W × D × H)	mm	Including the connector. Not including the antenna.
Unit weight	24	g	

■ 2.3.2 RS232C interface specifications

Communication method	Serial communication (RS232C format)
Synchronization	Asynchronous
Data speed	1,200 / 2,400 / 4,800 / 9,600 / 19,200 / 38,400 / 57,600 bps
Flow control	RTS/CTS hardware flow control
Other parameters	Data length 8 bits, no parity, 1 or 2 stop bits
RS232C output level	+/-5 V (power 3.2 V)
Connector	D-Sub 9-pin male

2.4 Channel Table

Refer to the operation guide of the MU-4 mounted on the MU4-RS2IF for the channel table. The frequency band is shown on the label of the MU-4.

2.5 External Dimensions

MU4-RS2 = MU-4 + MU4-RS2IF

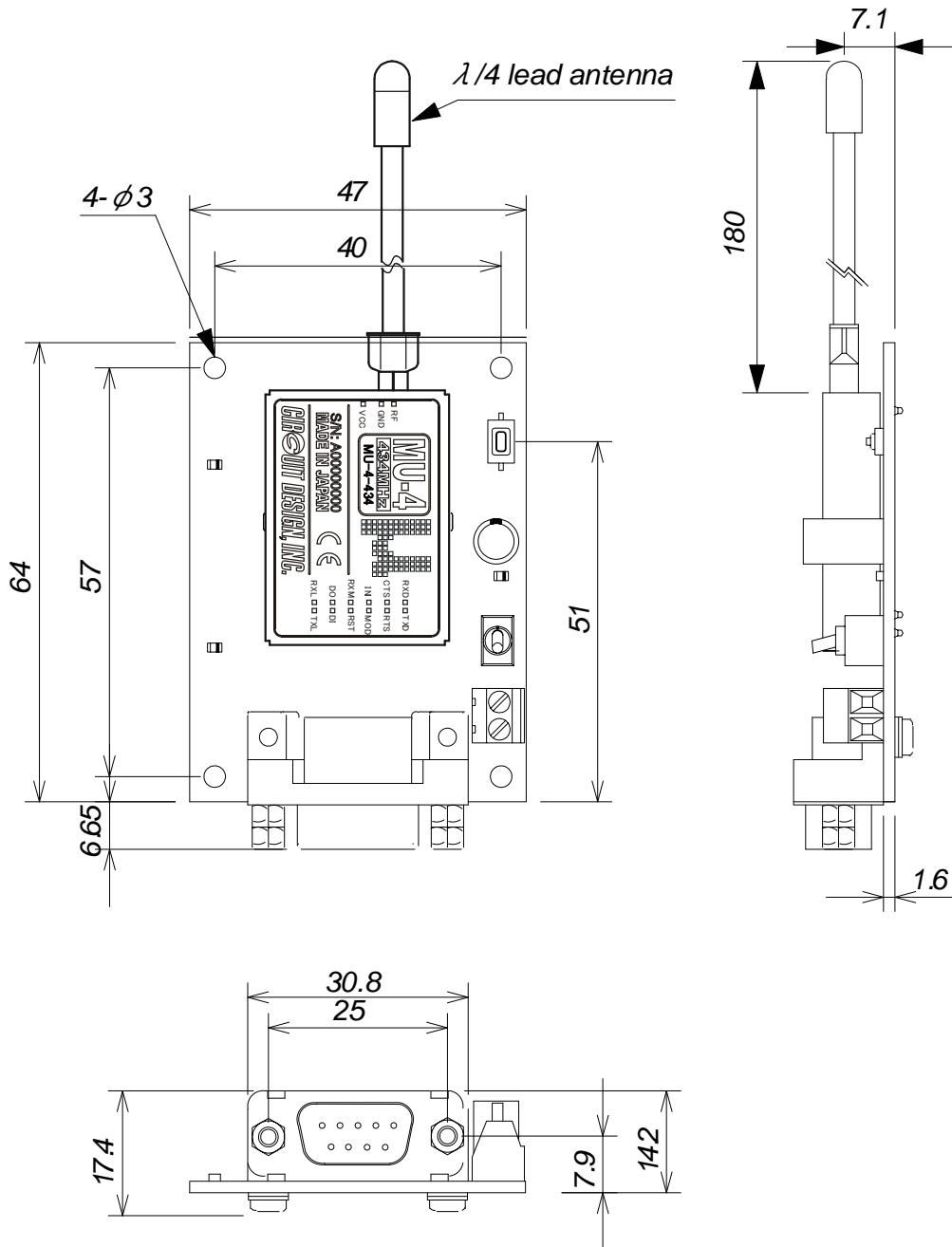

2.6 Circuit Diagram

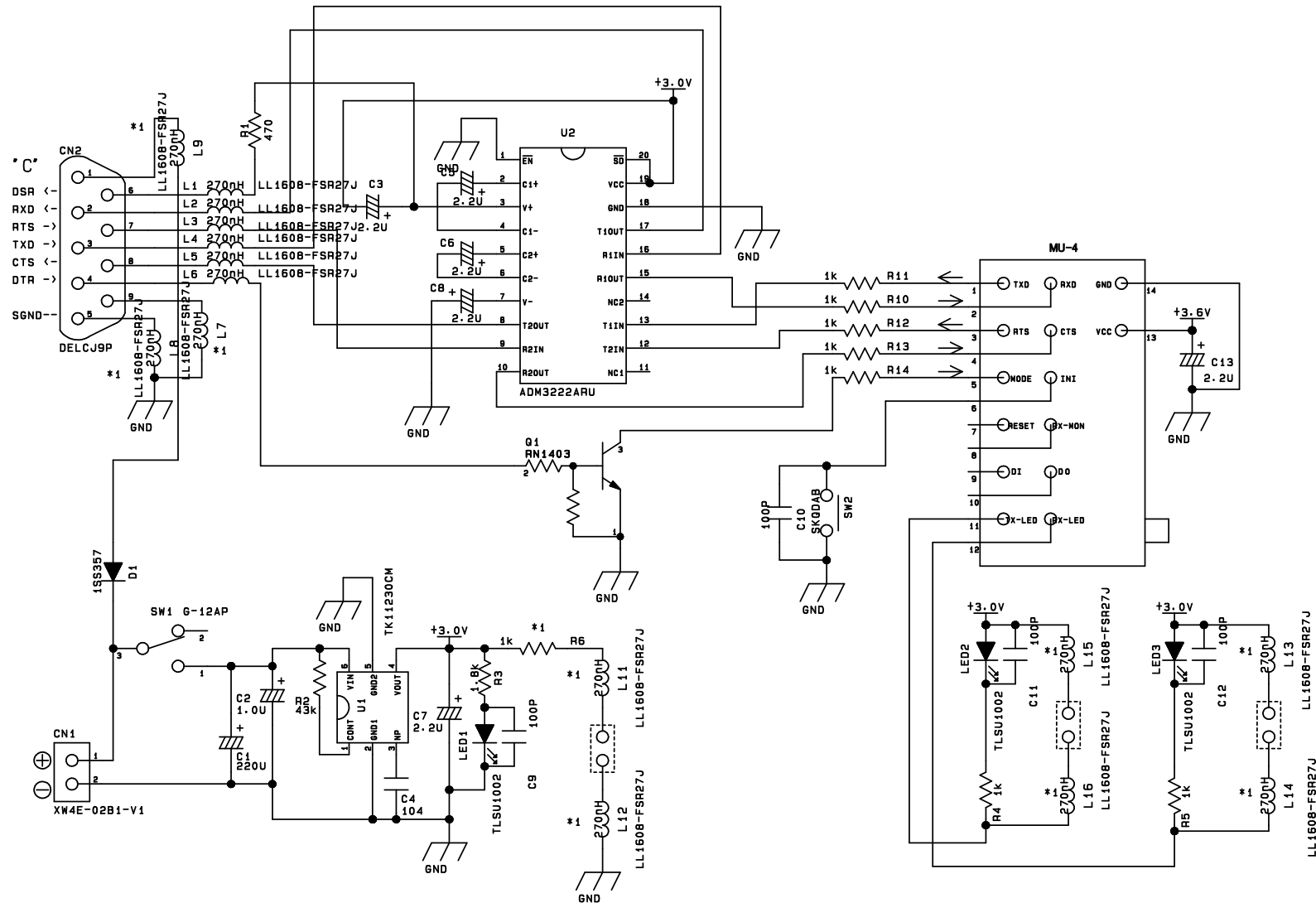

Chapter 3 How to Use the MU4-RS2

3.1 System Configuration Example

Since it is treated in the same way as the MU-4, refer to “Chapter 4 How to Use the MU-4” in the MU-4 operation guide.

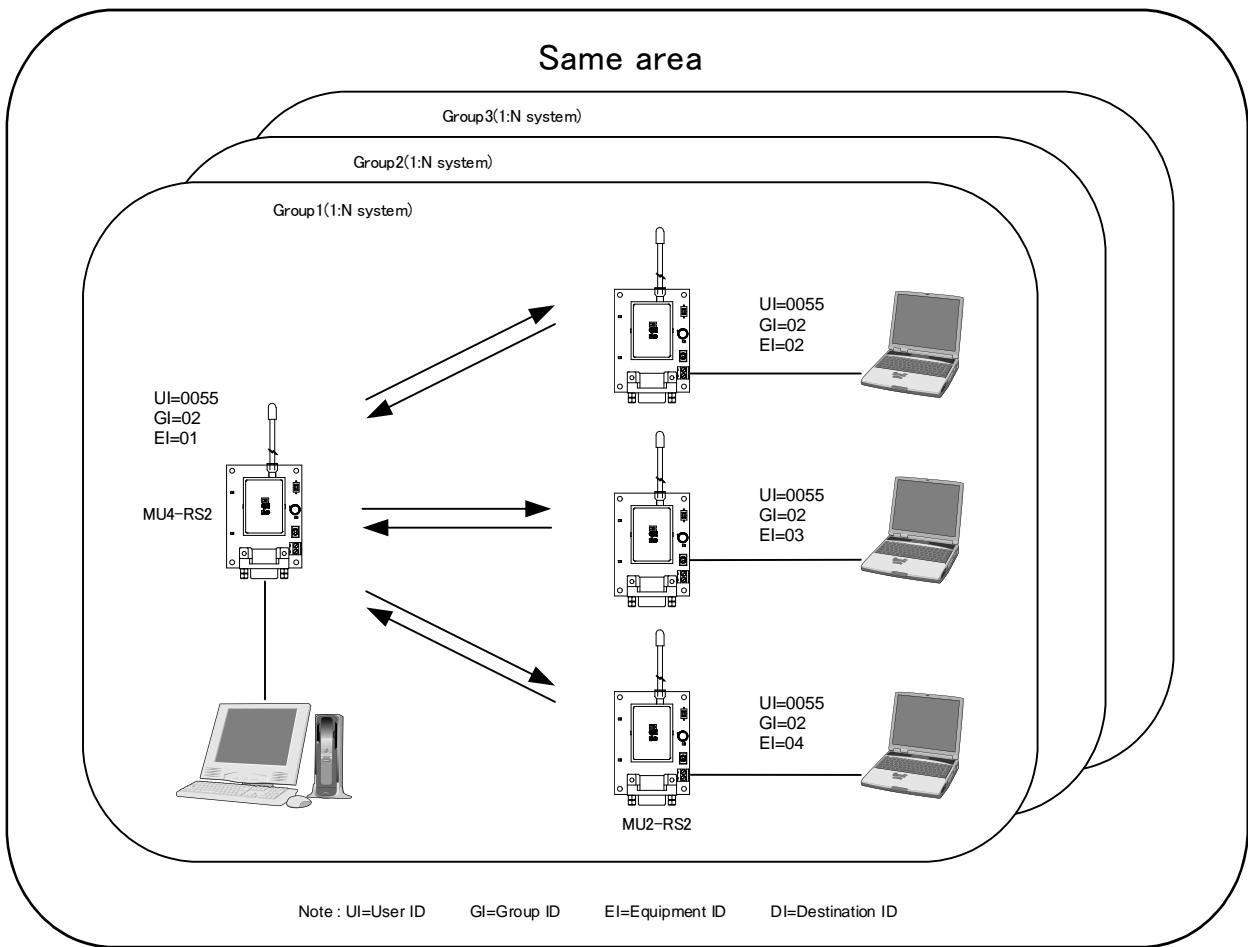

3.2 Resetting

Using the reset command @SR, the MU4-RS2 can be reset to the status when the power was turned on. The parameters set in the EEPROM remain unchanged.

3.3 Initializing

Reset the unit to the factory default settings if communication with the MU-4 mounted on the MU4-RS2 is not possible or if you are uncertain of the internal settings.

How to initialize the MU-4

Turn on the power while pressing the initialize button. Then turn the power off and on once again to reset the unit to the default settings. For details of the default status, refer to the default values for each command in the MU-4 Operation guide.

The MU-4 can also be initialized using the initialize command @IZ.

Status after initializing

The values of the main parameters after initializing are as follows.

1. Link related parameters
User ID: UI = 0000, Group ID: GI = 00, Equipment ID: EI = 01, Destination ID: DI = 01, Channel = 0 channel
2. UART related parameters
Baud rate = 19,200 bps, parity = none, stop bit = 1
3. Parameters related to internal operation
Mode = command

3.4 Connection example

The diagram below is an example of how to connect the MU4-RS2 and the single-chip CPU. Insert an RS232C transceiver in the CPU signal line.

Since the MU4-RS2 DTR line is connected to the MU-4 MODE terminal, be sure to control the level in accordance with the MU-4 mode being used.

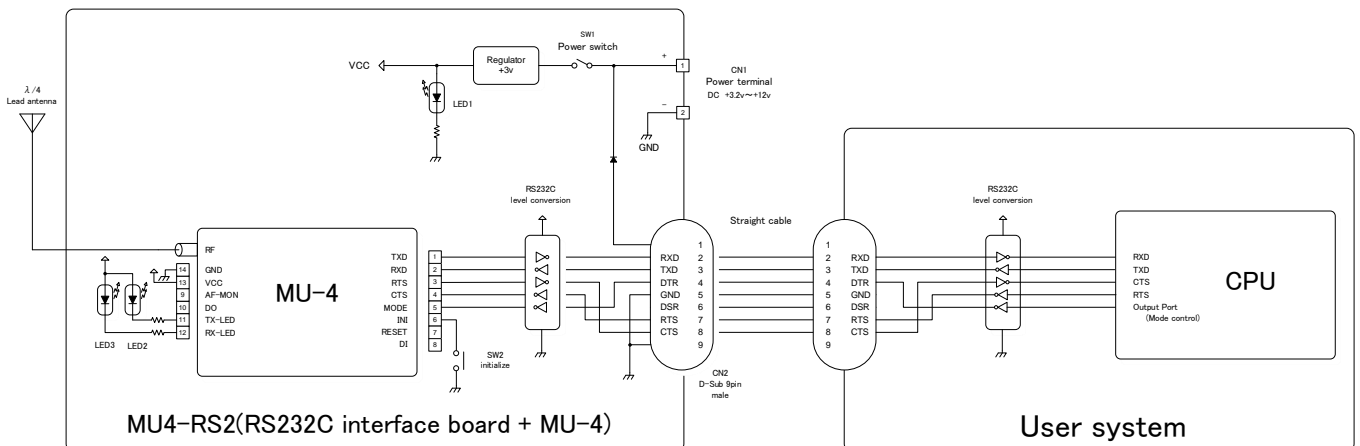

Chapter 4 How to Design a User System

The MU4-RS2 is not optimized from the point of view of physical functionality for embedding in final products. When designing systems that use the RS232C interface, we recommend that you refer to the circuit diagram of the MU4-RS2 given in this operation guide, and implement the interface part in your user system. When using the MU4-RS2 without further modification, ground the unit from the MU-4 leg nearest the antenna (the leg on the soldered side) to the case. Moreover, determine the position and number of grounds through testing.

4.1 Embedding the Product

If you house the product in a case, determine the position of the ground and antenna through a variety of tests. External LED terminals have been newly added to this product. In addition, if you attach LEDs to the case, connect them with inch-pitch through holes with reference to the diagram below.

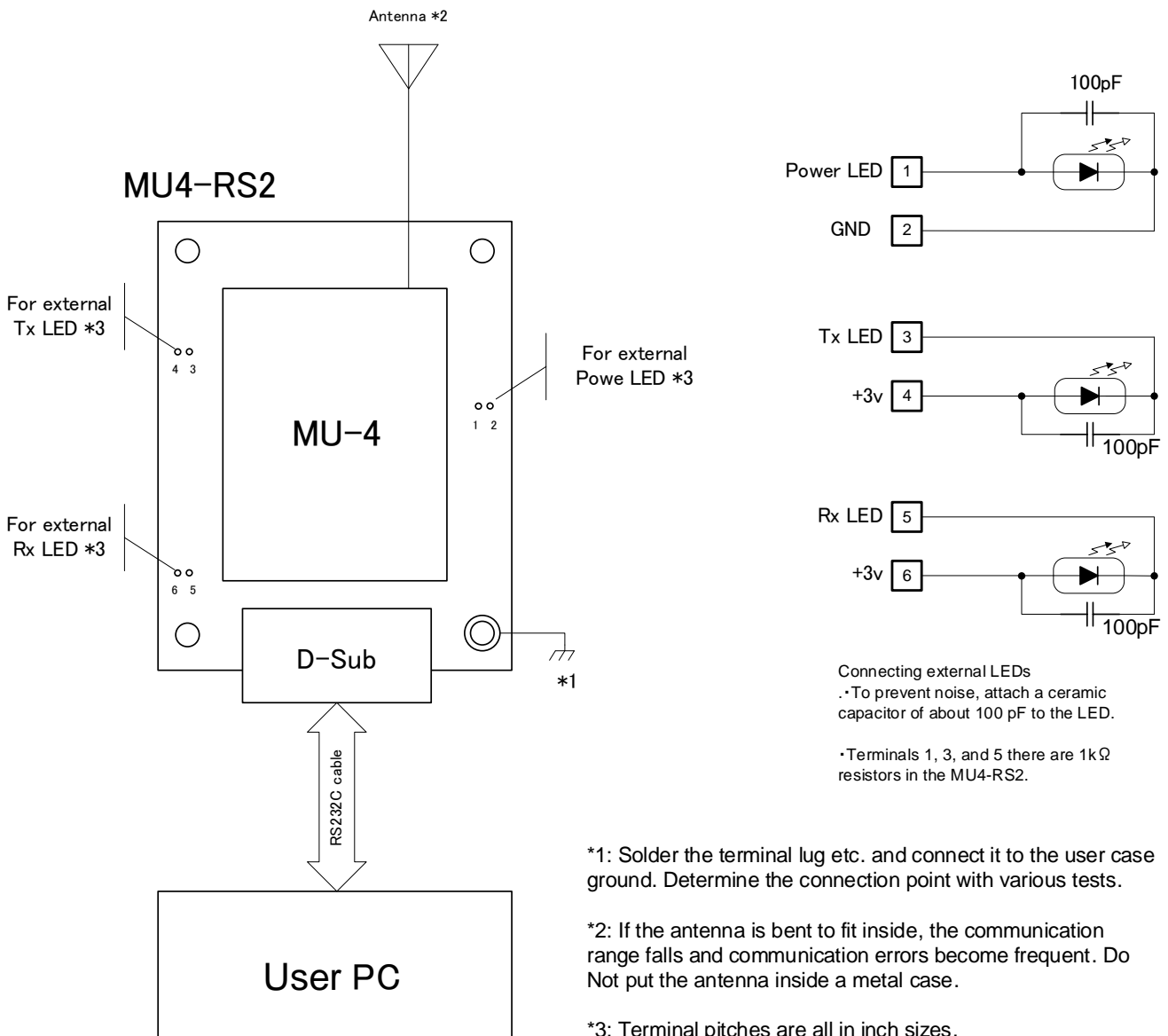

4.2 The Antenna

In systems where a non-directional antenna is required, it is important that the antennas of the transmitting station and target stations stand vertically in order to exploit communication performance to the maximum. If the planes of polarisation of the radio waves do not match, receive sensitivity may drop significantly.

Note that if, for reasons peculiar to the equipment, the antenna must be inside the case, communication performance will be very significantly degraded when handled in the following ways, since these methods contravene antenna theory. It is the responsibility of the user to test performance thoroughly when designing equipment.

1. Putting the antenna inside a metal case
2. Wrapping the antenna around the circuit board
3. Locating the antenna beside the ground pattern of the circuit board
4. Fitting the antenna inside by bending it
5. Cutting the antenna to make it shorter

The antenna provided with the MU-4 is a $1/4\lambda$ whip antenna. Whip antennas are antennas that substitute the ground as one end of a dipole antenna. For this reason the ground has a very important meaning. Although the main unit of the MU-4 has the function of a ground, in order to exploit its performance fully, connect it to the largest possible ground pattern when mounting the MU-4 on your circuit board.

In addition, in the case of two way communication between fixed stations, inclining the whip antenna of the MU-4 forwards may increase its communication range. Carry out tests in the specific environment of use.

4.3 Regulatory Compliance

The MU4-RS2 is a product that uses an RS232C interface to interface with external equipment. If the MU4-RS2 is used embedded in a final product, the regulatory compliance assessment in accordance with the RE Directive depends on the final product. Regulatory compliance assessment should be carried out on the responsibility of the manufacturer of the final product.

For details of the CE mark, refer to the MU-4 Operation Guide.

☞ Point:

The MU-4 radio modem has passed the regulatory compliance assessment in accordance with RE Directive a stand-alone product, and has received the CE mark.

4.4 Cautions

1. Devise ways of isolating the unit as far as possible from noise from other embedded equipment and from other sources of noise.
2. Arrange the system equipment so that it will not be covered by the operator's hand or the like.
3. The MU-4 does not have a waterproof structure. If the antenna is located outside the main unit, use a structure that prevents water droplets from entering the case.

Chapter 5 How to Develop a Program

The program that controls the MU4-RS2 (MU-4 + MU4-RS2IF) is a program that accesses the COM port. The method of developing a program is basically the same as for the MU-4, except for accessing a virtual COM port. Refer to “Chapter 6 How to Develop a Program” in the MU-4 Operation Guide.

Important notice

- Customers are advised to consult with Circuit Design sales representatives before ordering.

Circuit Design believes the provided information is accurate and reliable. However, Circuit Design reserves the right to make changes to this product without notice.

- Circuit Design products are neither designed nor intended for use in life support applications where malfunction can reasonably be expected to result in significant personal injury to the user. Any use of Circuit Design products in such safety-critical applications is understood to be fully at the risk of the customer and the customer must fully indemnify Circuit Design, Inc for any damages resulting from any improper use.
- As the radio module communicates using electronic radio waves, there are cases where transmission will be temporarily cut off due to the surrounding environment and method of usage. The manufacturer is exempt from all responsibility relating to resulting harm to personnel or equipment and other secondary damage.
- The manufacturer is exempt from all responsibility relating to secondary damage resulting from the operation, performance and reliability of equipment connected to the radio module.

Copyright

- All rights in this operation guide are owned by Circuit Design, Inc. No part of this document may be copied or distributed in part or in whole without the prior written consent of Circuit Design, Inc.

Cautions

- Do not use the equipment within the vicinity of devices that may malfunction as a result of electronic radio waves from the radio module.
- Communication performance will be affected by the surrounding environment, so communication tests should be carried out before actual use.
- Ensure that the power supply for the radio module is within the specified rating. Short circuits and reverse connections may result in overheating and damage and must be avoided at all costs.
- Ensure that the power supply has been switched off before attempting any wiring work.
- The case is connected to the GND terminal of the internal circuit, so do not make contact between the '+' side of the power supply terminal and the case.
- When batteries are used as the power source, avoid short circuits, recharging, dismantling, and pressure. Failure to observe this caution may result in the outbreak of fire, overheating and damage to the equipment. Remove the batteries when the equipment is not to be used for a long period of time. Failure to observe this caution may result in battery leaks and damage to the equipment.
- Do not use this equipment in vehicles with the windows closed, in locations where it is subject to direct sunlight, or in locations with extremely high humidity.
- The radio module is neither waterproof nor splash proof. Ensure that it is not splashed with soot or water. Do not use the equipment if water or other foreign matter has entered the case.
- Do not drop the radio module or otherwise subject it to strong shocks.
- Do not subject the equipment to condensation (including moving it from cold locations to locations with a significant increase in temperature.)
- Do not use the equipment in locations where it is likely to be affected by acid, alkalis, organic agents or corrosive gas.
- Do not bend or break the antenna. Metallic objects placed in the vicinity of the antenna will have a great effect on communication performance. As far as possible, ensure that the equipment is placed well away from metallic objects.
- The GND for the radio module will also affect communication performance. If possible, ensure that the case GND and the circuit GND are connected to a large GND pattern.

Warnings

- Do not take a part or modify the equipment.
- Do not remove the product label (the label attached to the upper surface of the module.) Using a module from which the label has been removed is prohibited.

Copyright 2020, Circuit Design, Inc.

REVISION HISTORY

Version	Date	Description	Remark
1.0	Sep. 2020	MU4-RS2IF The first issue	