



ANATECH ELECTRONICS INC
RF & Microwave Filters & Products

310 MHz LC Bandpass Filter

Part Number: AE310B10542



Electrical Specifications

Center Frequency: 310 MHz
3 dB Bandwidth: 380 MHz
Passband: 120MHz to 500 MHz
Return loss: 15dB
Impedance: 50 Ohms
Rejection: <20dB @ <30 MHz
Rejection2: <20dB @ >2000 MHz
Insertion loss: 3 dB 120 to 500 MHz
Insertion loss2: 3 dB @310 MHz

Mechanical

Connector Type: SMA(Female)
Dimensions: 1.50" X 0.75" x 0.5" in.

Environmental

Operating Temperature: -25°C to +70°C
Storage Temperature: -40°C to +90°C
Shock: 10 G. 11ms
Vibration: 10 G. 5 to 200Hz

Outline Drawing:

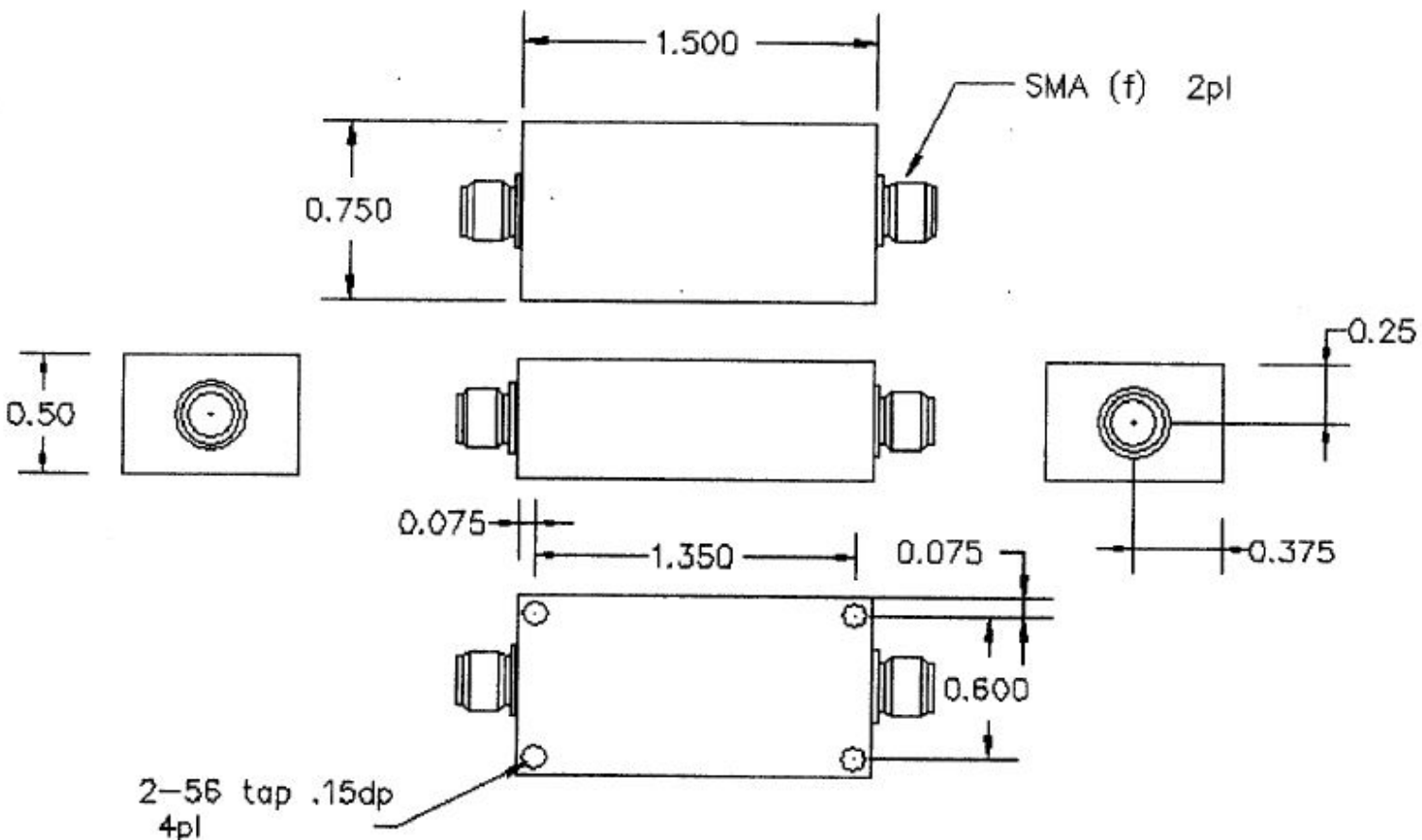



ANATECH ELECTRONICS INC
RF & Microwave Filters & Products

310 MHz LC Bandpass Filter

Part Number: AE310B10542



Response Plot:

