

User Manual

RaspBee™



Document Version V1.6
2017-12-10



Table of contents

1. Overview	6
2. Applications	6
3. Features	6
3.1. Short facts	6
3.2. How does the RaspBee work?	7
4. Quick start	8
4.1. Content of delivery	8
4.2. Requirements	9
4.2.1. Hardware	9
4.2.2. Software	9
4.3. Setup the components	9
5. Preconfigured image	10
5.1. Install and start the application without preconfigured image	10
6. Software	10
6.1. deCONZ on RPi	11
6.1.1. Installation	11
6.1.2. Configure serial port	11
6.1.3. Start and run the application	11
6.1.4. Autostart deCONZ GUI on boot	11
6.1.5. Autostart deCONZ headless on boot	12
6.2. Notes on custom firmware	12
6.3. GCFFlasher	12
6.3.1. Installation	12
6.3.2. Commands	12
6.3.3. Flash firmware file	13
6.4. EEPROM layout	13
6.5. Fuse setting	13
7. LED user interface	14



8. Technical data	15
9. Mechanical size	18
9.1. Dimensions	18
9.2. Housing	18
10. Pin assignment	19
11. Hardware modifications	20
11.1. Assemble the service header	21
11.2. Using an external antenna	21
12. Radio certification	22
12.1. United States (FCC)	22
12.2. European Union (ETSI)	22
12.3. Approved antenna list	23
13. Ordering information	23
14. Packaging dimension	24
15. Revision notes	24
References	25



Document history

Date	Version	Description
2013-07-22	1.0	Initial version
2013-09-09	1.1	Update of radio certification section due to successful passed certification Availability of basic variant included
2016-04-04	1.2	Including support of RPi2 and RPi3 RaspBee basic is obsolete
2016-04-04	1.3	Update Raspbian Jessie UART configuration
2017-04-25	1.4	Adjust installation of the deCONZ software
2017-07-20	1.5	Add installation firmware by using GCFFlasher
2017-12-10	1.6	Update deCONZ installation for Raspbian Jessi and Stretch. Update preconfigured SD-card image from Raspbian Jessi to Stretch. Document deCONZ GUI and headless autostart. Add GCFFlasher description. Introduce Phoscon App as WebApp update.



Abbreviations

Abbreviation	Description
IEEE 802.15.4	Communication standard, applicable to low-rate Wireless Personal Area Networks (WPAN)
CE	Consumer Electronics
ETSI	European Telecommunications Standards Institute
FCC	Federal Communications Commission
GPIO	Generals Purpose Input Output
JTAG	Joint Test Action Group, digital interface for debugging of embedded devices, also known as IEEE 1149.1 standard interface
MAC	Medium (Media) Access Control
MCU, μ C	Microcontroller Unit
OS	Operating System
RF	Radio Frequency
RPi	Raspberry Pi, a famous inexpensive single board computer in credit card size
R&TTE	Radio and Telecommunications Terminal Equipment (Directive of the European Union)
U[S]ART	Universal [Synchronous/]Asynchronous Receiver Transmitter
ZHA	ZigBee Home-Automation profile
ZigBee	Low-cost, low-power wireless mesh network standard. The ZigBee Alliance is a group of companies that maintain and publish the ZigBee standard.
ZHA	ZigBee Home Automation profile
ZLL	ZigBee Light Link profile



1. Overview

The RaspBee™ is a ZigBee addon board for the Raspberry Pi (RPI). By using the RaspBee the Raspberry Pi becomes a full functional wireless node which can be seamlessly integrated into ZigBee networks. This will enhance the application range of RPi with monitoring and controlling ZigBee networks. ZigBee compatible devices are available from a lot of manufacturers.

The RaspBee addon board has been designed to interconnect with the RPi standard user header. Due to its slim size the RPi still fits into most housings available on the market.

The addon board contains a powerful radio module with integrated power amplifier and low noise amplifier. Together with the assembled onboard chip antenna which has been optimally tuned this ensures a superior RF performance.

The RaspBee board “premium” is shipped with a pre-flashed ZigBee firmware. In delivery condition it includes a bootloader for simple firmware updates.

The ZigBee firmware is interfaced by a program called deCONZ which runs on the RPi and is responsible for ZigBee network control and monitoring.

Basically, the RaspBee is a reference design for the ZigBee radio module deRFmega256-23M12 by dresden elektronik.

2. Applications

Mainly the RaspBee is designed to handle ZigBee 3.0, ZigBee Light Link (ZLL) and ZigBee Home Automation (ZHA) applications in connection with the RaspBee ZigBee firmware and RPi software deCONZ. A more detailed description of the ZLL standard, the features, benefits and available certified products can be found on the official alliance website [1].

It is also possible to use a custom firmware for wireless applications. Follow the instructions in **Sections 6** and **11** for detailed instructions on software installation and customer modifications.

Note: Regard that dependent on the modifications the radio certification and compliance may become invalid. Please get in contact with us to advise you for a custom FCC certified and/or compliant design.

3. Features

The RaspBee board contains the features listed below. **Figure 1** illustrates the feature parts in a detailed view.

3.1. Short facts

- Slim size: 48.0 x 16.5 x 12.0 mm
- Supply voltage: 5.0 V
- Onboard 2.4 GHz ZigBee radio module ‘deRFmega256-23M12’



- Application interfaces:
 - 1x UART, 1x Reset, 1x GPIO
 - User interface: 2x LED (red and green)

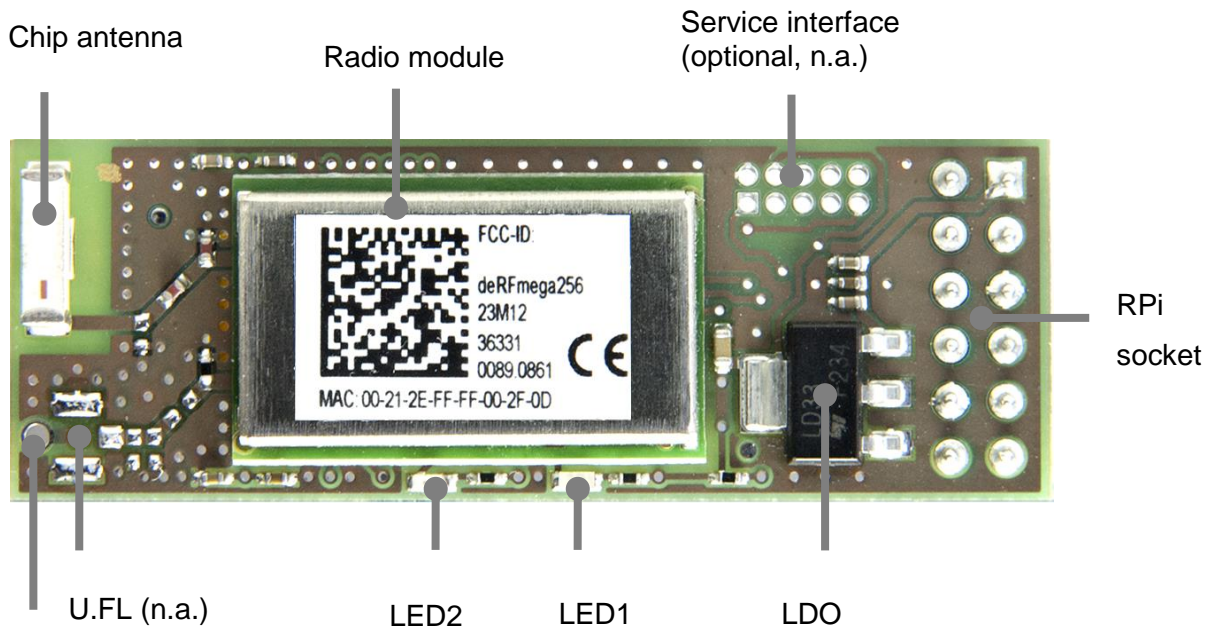

Wire antenna (n.a.)

Figure 1: RaspBee in detail

3.2. How does the RaspBee work?

The functional parts of the RaspBee are shown in a schematic overview in **Figure 2**.

The RaspBee will be supplied by the RPi 5.0 V domain. Therefore the AC/DC supply must be sufficient to support the additional load. The most used AC/DC converters for RPi supply enough power to compensate the slightly increased current consumption of the RaspBee. An onboard low-drop-out voltage regulator generates a stable 3.3 V voltage to supply the radio module and LEDs.

Note: All RaspBee signals (UART, RESET, GPIO, JTAG) work on a 3.3 V domain. A level shifting of the signals to other voltage domains may be required if the RaspBee is used on other base boards than the RPi.

The onboard placed radio module deRFmega256-23M12 by dresden elektronik contains an 8-bit AVR microcontroller with an integrated low-power 2.4 GHz transceiver for ZigBee and IEEE 802.15.4 applications. The firmware is stored in the MCU internal flash and starts automatically after the board gets powered on. Each RaspBee contains a world-wide unique identifier, named MAC-ID. It consists of an 8 byte address, including the vendor ID and product ID. The MAC-ID is stored in the MCU internal EEPROM.



Communication between RPi and RaspBee is established via UART interface by using a proprietary protocol. The application protocol frames which are used by the deCONZ application to communicate with the microcontroller are encapsulated in the Serial Line Internet Protocol (SLIP).

The used signals are TXD and RXD without any handshake signals. It is important to enable the access to RPi serial port (see **Section 6.1.2**) to ensure the proper function. Two user LEDs (red, green) are available to show RaspBee status. The low-active reset signal can be controlled by the RPi and will cause a hardware reset of the built-in microcontroller. An onboard 10k pull-up resistor avoids an unintended reset trigger.

Via a service adapter footprint the JTAG signals of the built-in microcontroller are available. In delivery state the adapter header is not assembled. See **Section 11.1** for a custom modification.

The 2.4 GHz radio module has two RF output traces. In default delivery state, only one RF line is used which is routed to the assembled onboard chip antenna. Each firmware shall ensure that the correct RF port gets selected. Although the chip antenna covers most of the applications it is also possible to use an external antenna. This requires custom modifications described in **Section 11.2** as well as firmware changes.

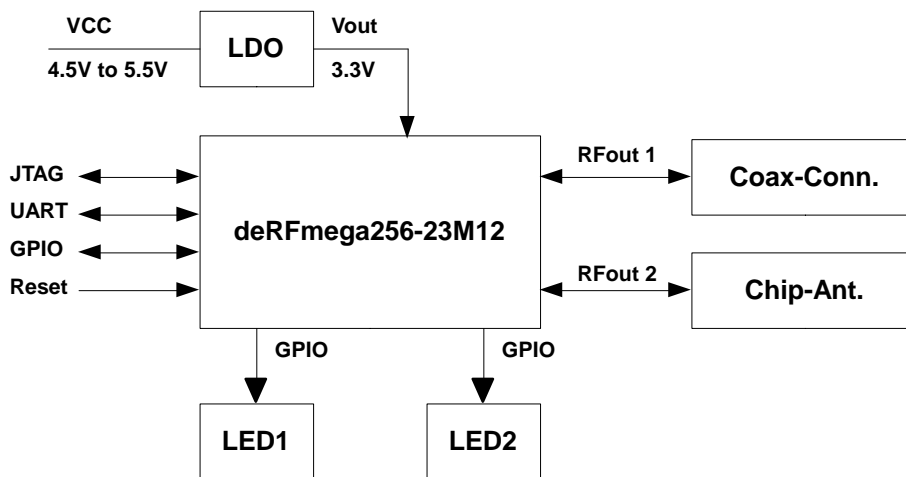

Figure 2: Block Diagram

4. Quick start

This section describes in short steps a fast start-up of the RaspBee board to control and monitor a ZigBee network. Detailed descriptions about the firmware, software and functionality can be found in **Section 6**.

4.1. Content of delivery

One shipped RaspBee package contains the following:

- 1x RaspBee board



-
- 1x Instruction leaflet

4.2. Requirements

The RaspBee is designed to work on a Raspberry Pi. In general all actual available types of RPi will work with the RaspBee. However we recommend RPi type B, RPi2 and RPi3 with assembled Ethernet components. For full functionality the following additional components are required:

4.2.1. Hardware

- Raspberry Pi (type B), RPi2 or RPi3
- Recommended Power supply for Raspberry Pi, RPi2 or RPi3 (AC/DC to Micro-USB, 5.0 V DC, min. 2 A)
- SD card / MicroSD card for OS and software

4.2.2. Software

- Linux operating system (Raspbian Jessie or Stretch¹)
- deCONZ for ARMv6 Linux²
- ZigBee firmware for RaspBee³ (optionally)

4.3. Setup the components

1. Unpack the RaspBee unit.
2. Please make sure that the Pi is switched off.
3. Connect the RaspBee to the RPi user header. Pin 1 of RaspBee (square marker) must be connected to Pin 2 of RPi header P1 at the board edge. Use the same header position for RPi2 or RPi3.

¹ Refer to <http://www.raspbian.org/> for download and installation instructions

² deCONZ is available in the download area on <http://www.dresden-elektronik.de>

³ ZigBee firmware is available in the download area on <http://www.dresden-elektronik.de>. (section deCONZ, file extension `.bin.GCF`).

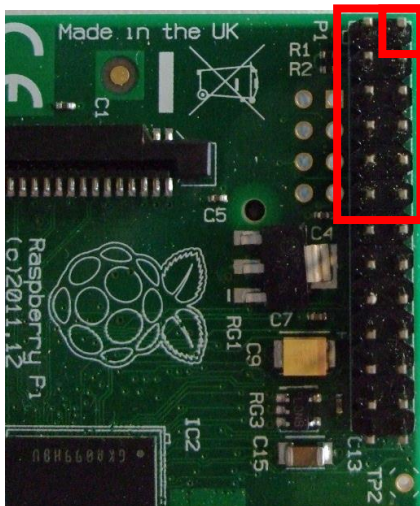

Figure 3: RPi user header

- Notes:**
- Double check that the header is **NOT** shifted inadvertently since this may damage the RaspBee board irreversible.
 - Do not connect the RaspBee if the RPi is powered since this will cause a restart of the host device.

5. Preconfigured image

We recommend the use of the preconfigured MicroSD-card image with Raspbian Stretch, deCONZ and VNC-Server which is available for download here:

<https://www.dresden-elektronik.de/funktechnik/solutions/wireless-light-control/raspbee-gw-sd-card-image/?L=1>

Otherwise, please follow the installation instructions of the **chapter 5.1**.

1. Power-On the RPi and wait until the main screen is available
2. The deCONZ application starts automatically.

5.1. Install and start the application without preconfigured image

3. Power-On the RPi and wait until the login prompt is available.
4. Log in and acquire superuser rights.
5. Install the ZigBee control and monitoring software 'deCONZ' on RPi (see **Section 6.1.1**).
6. Start the deCONZ application (see **Section 6.1.3**).

6. Software

All following explanations assume the customer fulfils the software prerequisites as given in **Section 4.2.2** and the initial setup (see **Section 4.3**) has been performed.



6.1. deCONZ on RPi

deCONZ is a powerful program which allows the configuration, operation, monitoring and maintenance of ZigBee networks.

6.1.1. Installation

1. Download deCONZ software package:

```
$ wget http://www.dresden-elektronik.de/rpi/deconz/deconz-latest.deb
```

2. Install deCONZ software package:

Important: This step might print some errors due missing dependencies; that's expected and will be fixed afterwards in the step 3.

```
$ sudo dpkg -i deconz-latest.deb
```

3. Install missing dependencies:

```
$ sudo apt update  
$ sudo apt install -f
```

6.1.2. Configure serial port

1. Open RPi config tool

```
$ sudo raspi-config
```

2. Select "Interfacing Options"

3. Select "Serial"

4. "Would you like a login shell to be accessible over serial?" → <No>

5. "Would you like the serial port hardware to be enabled?" → <Yes>

6. Exit config tool and reboot RPi

6.1.3. Start and run the application

1. If not already running start the desktop environment

```
$ startx
```

2. Start deCONZ application from start menu

Menu / Programming / deCONZ

The application shall now connect to the RaspBee shield automatically and a blue node with address 0x0000 which represents the RaspBee coordinator appears. For details on the operation, refer to the deCONZ user manual [2]. Once running, deCONZ is also accessible via browser based Phoscon App [3].

6.1.4. Autostart deCONZ GUI on boot

Use this if deCONZ GUI should be started automatically on each boot.

1. Enable deCONZ systemd GUI service

```
$ sudo systemctl enable deconz-gui
```



6.1.5. Autostart deCONZ headless on boot

Use this to start deCONZ on each boot in a headless environment, without a running X11 or VNC server.

1. Enable deCONZ systemd headless service

```
$ sudo systemctl enable deconz
```

6.2. Notes on custom firmware

For communication between RPi and Raspberry, set the UART speed to 38400 baud preferably. To upload the firmware or recover the ZigBee firmware, use GCFFlasher⁴.

Notes: When using the JTAG interface, do not touch sensitive EEPROM areas (Bootloader control section, ZigBee firmware settings, NV-section containing i.e. MAC address) unless you are absolutely sure what you are doing.

Please also note that dresden elektronik will neither provide firmware images of the bootloader nor support restoring the bootloader or EEPROM once overwritten.

6.3. GCFFlasher

GCFFlasher is a command line tool for which can be used to update the RaspBee firmware without additional programming hardware. It is also used by deCONZ if the ZigBee firmware needs to be updated.

GCFFlasher accepts firmware files in binary file format and in dresden elektronik proprietary GCF file format. There is no EEPROM programming support within GCFFlasher. EEPROM programming must be done within your application code. Please note that modifying the EEPROM may cause irreversibly damage to your RaspBee board. Use with care. GCFFlasher also provides the option '-r' to set the target device into reset state.

6.3.1. Installation

1. Download GCFFlasher

```
$ wget http://www.dresden-  
elektronik.de/rpi/gcflasher/gcflasher-latest.deb
```

2. Install GCFFlasher

Important: This step might print some errors due missing dependencies; that's expected and will be fixed afterwards in the step 3.

```
$ sudo dpkg -i gcflasher-latest.deb
```

3. Install missing dependencies:

```
$ sudo apt update  
$ sudo apt install -f
```

6.3.2. Commands

The GCFFlasher command description is available by start the program:

⁴ Images of the ZigBee Firmware are available in the download section on <http://www.dresden-elektronik.de>



```
$ sudo GCFFlasher
```

The available commands are:

- r force device reset without programming
- f <firmware> flash firmware file
- d <device> device to use
- sn <serial> FTDI device with serial number to use
- l list devices
- h -? print this help

Note: The FTDI based commands are only applicable for firmware uploads of the ZigBee USB Dongle ConBee. See <https://www.dresden-elektronik.de/funktechnik/solutions/wireless-light-control/conbee/> for product details.

6.3.3. Flash firmware file

To upload the firmware, invoke GCFFlasher with superuser rights as follows:

```
$ sudo GCFFlasher -f <filename>.bin.GCF
```

6.4. EEPROM layout

The radio module contained on the RaspBee uses the following EEPROM sections. If developing custom firmware, please do not modify the sections already used.

Table 1: EEPROM sections

EEPROM sections	
<i>address range</i>	<i>content / remark</i>
0x0000 ... 0x00FF	Bootloader specific
0x0100 ... 0x1EFF	user available
0x1F00 ... 0x1FDF	ZigBee firmware specific
0x1FE0 ... 0x1FFF	NV-section

6.5. Fuse setting

The table below shows the recommended fuse byte settings for the RaspBee which the board also comes with in factory new condition. Please refer to the radio module user manual [4] for their description and alternative configurations.

Table 2: Extended fuse bytes

Fuse bytes	Setting	Description
EXTENDED	0xF8	Extended fuse byte
HIGH	0x90	Fuse high byte



LOW	0xCE	Fuse low byte
-----	------	---------------

7. LED user interface

The LED user interface consists of a red and a green low-active low-current LED. They show the actual status of the RaspBee board (**Table 3**).

Table 3: LED status

LED status			
<i>Application</i>	<i>Application state</i>	<i>LED1 (red)</i>	<i>LED2 (green)</i>
Bootloader	during initial 200 ms after start (awaiting commands)	Off	Blinking
	firmware update	Off	Blinking
	no target application (invalid Firmware/empty FLASH)	Off	Blinking
	target application started	depending application	
ZigBee firmware	Idle mode (TRX OFF)	Fast blinking	Off
	Connecting	Slow blinking	Off
	Connected	On	Off
	Transmit	Off	On
	Transmitted	Off	Off
custom firmware	n/a	depending application	



8. Technical data

The RaspBee contains the 2.4 GHz IEEE 802.15.4 radio module 'deRFmega256-23M12' by dresden elektronik. A detailed description of the module's characteristics and properties can be found in the radio module user manual [4].

Table 4: Mechanical data

Mechanical data						
Value	Descriptor	Parameter	Min	Typ	Max	Unit
Size	L			48.0		mm
	W			16.5		mm
	H			12.0		mm

Table 5: Temperature range

Temperature range ⁵						
Value	Descriptor	Parameter	Min	Typ	Max	Unit
Working temperature	T _{work}		-40	+25	+85	°C

Table 6: Absolute maximum ratings

Absolute maximum ratings						
Value	Descriptor	Parameter	Min	Typ	Max	Unit
Supply voltage	V _{in_max}	T=25°C			5.5	V
Supply current	I _{in_max}	TX_ON, TX_PWR=0x0			215	mA

Note: Stresses beyond those listed under “Absolute maximum ratings” may cause permanent damage to the device. This is a stress rating only and functional operation of the device at these or any other conditions beyond those indicated in the operational sections of this manual are not implied. Exposure to absolute maximum rating conditions for extended periods may affect device reliability. For more details about these parameters, refer to individual datasheets of the components used.

⁵ The given values are only valid for the RaspBee board. They may differ from the Raspberry Pi or other custom base boards. Check the appropriate documentations for the working and storage temperature of the whole system.



Table 7: Electrical characteristics

Electrical characteristics						
<i>Value</i>	<i>Descriptor</i>	<i>Parameter</i>	<i>Min</i>	<i>Typ</i>	<i>Max</i>	<i>Unit</i>
Supply voltage	V _{in}		4.5	5.0	5.5	V
Output voltage	V _{out}			3.3		V
Supply current	I _{in_trxoff}	V _{in} =5.0 V		15.8		mA
	I _{in_txon}	V _{in} =5.0 V, TX_PWR=0x0		213.7		mA
		V _{in} =5.0 V, TX_PWR=0x6		168.2		mA
		V _{in} =5.0 V, TX_PWR=0xF		55.1		mA
I _{in_rxon}		V _{in} =5.0 V, Max. Sens.		32.0		mA
		V _{in} =5.0 V, Reduced Sens.		31.7		mA
		V _{in} =5.0 V, RPC On		26.6		mA

Table 8: MCU clock

MCU clock						
<i>Value</i>	<i>Descriptor</i>	<i>Parameter</i>	<i>Min</i>	<i>Typ</i>	<i>Max</i>	<i>Unit</i>
MCU clock	CLK _{MCU}			8		MHz

Table 9: Radio characteristics

Radio characteristics						
<i>Value</i>	<i>Descriptor</i>	<i>Parameter</i>	<i>Min</i>	<i>Typ</i>	<i>Max</i>	<i>Unit</i>
Antenna	ANT1	Type	Chip Ceramic			
		Gain		-0.7		dBi
Coaxial connector	COAX	Type	U.FL			
Frequency range	F _{range}	PHY_CC_CCA = 0x0B..0x1A	2405		2480	MHz
Channels	CH	PHY_CC_CCA = 0x0B..0x1A	16			



Absolute TX power	POUT	Vin=5.0 V, TX_PWR=0x0	20.9	dBm
		Vin=5.0 V, TX_PWR=0x6	19.6	dBm
		Vin=5.0 V, TX_PWR=0xF	3.0	dBm
Receiver sensitivity	SENS	Data Rate = 250 kBit/s	-105	dBm
		Data Rate = 500 kBit/s	-101	dBm
		Data Rate = 1000 kBit/s	-99	dBm
		Data Rate = 2000 kBit/s	-94	dBm
Data rate (gross)	DR	TRX_CTRL_2 = 0x00	250	kbps
		TRX_CTRL_2 = 0x01	500	kbps
		TRX_CTRL_2 = 0x02	1000	kbps
		TRX_CTRL_2 = 0x03	2000	kbps



9. Mechanical size

9.1. Dimensions

The RaspBee board (**Figure 4**) has a length of 48.0 mm, a width of 16.5 mm and a height of 12.0 mm (including socket for RPi).

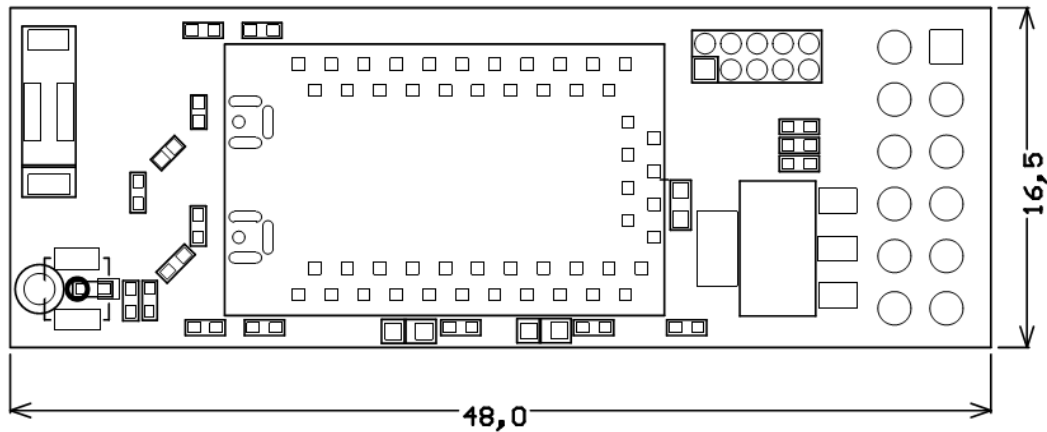

Figure 4: Mechanical size

9.2. Housing

The slim board size allows the usage of housing for the RPi. Tested and recommended items are:

- MULTICOMP - MC-RP001 white (FARNELL order code 2113797)
- MULTICOMP - MC-RP001 black (FARNELL order code 2113798)
- MULTICOMP - MC-RP001 clear (FARNELL order code 2113799)

Recommended housing for RPi2 and RPi3 is:

- RS Pro - ASM-1900036-11 (RS-Online order code 908-4212)



10. Pin assignment

This section lists all available signals and their function on the RaspBee.

Note: The signal NC means Not Connected.

Table 10: Signal pin description

Signal pin description			
<i>Radio module pin</i>	<i>Signal</i>	<i>Function</i>	<i>Comment</i>
28	PE0/RXD0	UART RX	Communication interface
29	PE1/TXD0	UART TX	Communication interface
4	RESET	Reset	10k pull-up onboard, low-active
27	PB7	SW1 / GPIO	
15	PD7	LED1	Red, low-active
8	PG2	LED2	Green, low-active
57	RFOUT1	Wire antenna or coaxial connector	Not assembled, trace terminated with 49R9 resistor
53	RFOUT2	Chip antenna	
48	PF4/TCK	JTAG	Header not assembled
47	PF5/TMS	JTAG	Header not assembled
46	PF6/TDO	JTAG	Header not assembled
45	PF7/TDI	JTAG	Header not assembled
-	Vin	Voltage supply	5 V supplied by RPi
2, 50	VCC	Voltage supply	3.3 V generated internally
1, 31, 44, 49, 51	GND	Ground	System ground

Table 11: Header pin description

Header pin description			
<i>Header</i>	<i>Pin</i>	<i>Signal</i>	<i>Comment</i>
RPi socket	1	Vin	5.0 V supplied by RPi



	2	NC	
	3	NC	
	4	NC	
	5	GND	
	6	NC	
	7	RXD	UART RX
	8	NC	
	9	TXD	UART TX
	10	GND	
	11	SW1	GPIO for RaspBee
	12	RESET	Reset signal for RaspBee
Service socket (not assembled)	1	TCK	JTAG
	2	GND	
	3	TDO	JTAG
	4	VCC	3.3 V generated internally
	5	TMS	JTAG
	6	RESET	Reset signal for RaspBee
	7	VCC	3.3 V generated internally
	8	NC	
	9	TDI	JTAG
	10	GND	

11. Hardware modifications

Besides the factory-default RaspBee configuration it is also possible to modify the hardware to enhance its functionality.



11.1. Assemble the service header

The service interface provides the microcontroller programming interface of the radio module. It is useful to assemble a 50 mil 10-pin header on the top side to ensure a proper connection. We recommend the use of the listed header:

- MOUSER ELECTRONICS order number: 855-M50-3500542
- FARNELL order number: 1022305
- DIGI-KEY order number: 952-1383-ND

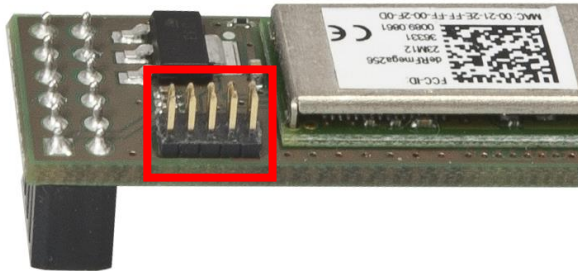

Figure 5: RaspBee service header (default not assembled)

The pin description can be found in **Section 10** in **Table 11**. A detailed description of suitable programmers and related software tools are listed in **[5]**.

Note: Improper handling in respect of erasing or overwriting the MCU internal flash or EEPROM completely or in parts may result in an unusable RaspBee unit. Modification of the pre-allocated EEPROM memory sections or removal of the pre-installed bootloader will irreversibly preclude restoring, booting or upgrading the shipping firmware at all. dresden elektronik will neither support such modifications (see **Section 6.2** for details).

11.2. Using an external antenna

External antennas will be often used if an improved radio characteristics performance is needed or the device is put into a metallized enclosure. In this case it is possible to assemble a surface-mount coaxial connector. The footprint is designed to use the coaxial connector 'U.FL-R-SMT-1(10)' by HIROSE. It can be obtained from i.e. the following distributors:

- MOUSER ELECTRONICS order number: 798-U.FL-R-SMT-110
- FARNELL order number: 1688077
- DIGI-KEY order number: H11891CT-ND

Additionally the terminating resistor must be removed from the antenna port. Assemble a 22 pF coupling capacitor and a 10 k resistor in parallel directly next to the U.FL connector.

The RaspBee has been tested and measured with the approved antenna(s) listed in **Section 12.3**.



Notes: The use of antenna types other than the listed approved antennas will cause in loss of the FCC certification. Regard the notes in **Section 12.3** to work with a custom antenna in respect of CE and FCC requirements.

The pre-installed ZigBee firmware does not support the 2nd antenna port.

12. Radio certification

12.1. United States (FCC)

The RaspBee contains the radio module 'deRFmega256-23M12', which is certified according to FCC part 15. The FCC-ID of the radio module deRFmega256-23M12 is XVV-MEGA23M12 and is printed on a visible permanently affixed label on the top of the module's RF shielding.

This equipment complies with Part 15 of the FCC Rules. Operation is subject to the following two conditions: (1) this device may not cause harmful interference, and (2) this device must accept any interference received, including interference that may cause undesired operation (FCC 15.19). The internal / external antenna(s) used for this mobile transmitter must provide a separation distance of at least 20 cm from all persons and must not be co-located or operating in conjunction with any other antenna or transmitter.

Modifications not expressly approved by the manufacturer could void the user's authority to operate this equipment (FCC section 15.21).

This equipment has been tested and found to comply with the limits for a Class A digital device, pursuant to Part 15 of the FCC Rules. These limits are designed to provide reasonable protection against harmful interference when the equipment is operated in a commercial environment. This equipment generates, uses, and can radiate radio frequency energy and, if not installed and used in accordance with the instruction manual, may cause harmful interference to radio communications. Operation of this equipment in a residential area is likely to cause harmful interference in which case the user will be required to correct the interference at their own expense (FCC section 15.105).

12.2. European Union (ETSI)

The RaspBee is conforming for use in European Union countries.

If the RaspBee is incorporated into a product, the manufacturer must ensure compliance of the final product to the European harmonized EMC and low-voltage/safety standards. A Declaration of Conformity must be issued for each of these standards and kept on file as described in Annex II of the R&TTE Directive.

The manufacturer must maintain a copy of the RaspBee documentation and ensure the final product does not exceed the specified power ratings, antenna specifications, and/or installation requirements as specified in the user manual. If any of these specifications are exceeded in the final product, a submission must be made to a notified body for compliance testing to all required standards.

The CE marking must be affixed to a visible location on the OEM product. The CE mark shall consist of the initials "CE" taking the following form:

- If the CE marking is reduced or enlarged, the proportions must be respected.
- The CE marking must have a height of at least 5 mm except where this is not possible on account of the nature of the apparatus.



- The CE marking must be affixed visibly, legibly, and indelibly.

More detailed information about CE marking requirements can be found in [6].

12.3. Approved antenna list

The RaspBee has an integrated chip antenna. The design is fully compliant with all regulations and certified as reference design of the radio module deRFmega256-23M12 (FCC-ID: XVV-MEGA23M12).

As approved antenna(s) in connection with the coaxial connector (see **Section 11.2**) and a suitable U.FL to RP-SMA adapter cable, the following antenna(s) are allowed to use:

Table 12-1: Approved antenna(s)

Approved antenna(s) for deRFmega256-23M12				
Type	Gain	Mount	Order code	Vendor / Supplier
<i>External antenna</i>				
2400 to 2483.5 MHz Rubber antenna	+5dBi (peak)	RP-SMA	17013.RSMA	WiMo
U.FL-to-RP-SMA pigtail, 15 cm	-0.5dB		BN-023769	dresden elektronik
<i>Integrated antenna</i>				
2400 to 2483.5 MHz Chip antenna	+1.3dBi (peak)	SMT	2450AT43B100	Johanson Technology

According to KDB 178919 it is allowed to substitute approved antennas through equivalent antennas of the same type:

'Equivalent antennas must be of the same type (e.g., yagi, dish, etc.), must be of equal or less gain than an antenna previously authorized under the same FCC ID, and must have similar in band and out-of-band characteristics (consult specification sheet for cutoff frequencies).'

Additional description to certification and approved antenna issues can be found in the radio module's user manual [4].

13. Ordering information

Table 2: Ordering Information

Ordering information		
Part Number	Product Name	Comment
BN-600052	RaspBee premium	Contains bootloader and ZigBee firmware



14. Packaging dimension

Default package size: 138 x 90 x 29 mm (LxWxH).

One package contains one RaspBee unit.

15. Revision notes

Actually no design issues are known.



References

- [1] ZigBee Light Link, URL: <http://www.zigbee.org/zigbee-products-2/>
- [2] User Manual deCONZ;
URL: <https://www.dresden-elektronik.de/funktechnik/service/downloads/documentation/>
- [3] Quick Start Guide Wireless Light Control, URL: https://www.dresden-elektronik.de/funktechnik/service/download/documentation/?L=1&eID=dam_frontend_push&docID=4621
- [4] User Manual deRFmega256 radio modules; URL: http://www.dresden-elektronik.de/funktechnik/service/downloads/documentation/?eID=dam_frontend_push&docID=1250
- [5] Software Programming User Manual; URL: http://www.dresden-elektronik.de/funktechnik/products/radio-modules/oem-derfmega/description/?L=0&eID=dam_frontend_push&docID=1917
- [6] Directive 1999/5/EC, European Parliament and the Council, 9 March 1999, section 12



dresden elektronik ingenieurtechnik gmbh
Enno-Heidebroek-Straße 12
01237 Dresden
GERMANY

Phone +49 351 31850-0

Fax +49 351 31850-10

Email wireless@dresden-elektronik.de

Trademarks and acknowledgements

- IEEE 802.15.4™ is a trademark of the Institute of Electrical and Electronics Engineers (IEEE).
- ZigBee® is a registered trademark of the ZigBee Alliance.
- RaspBee™ is a registered trademark of the dresden elektronik ingenieurtechnik gmbh.

All trademarks are registered by their respective owners in certain countries only. Other brands and their products are trademarks or registered trademarks of their respective holders and should be noted as such.

Disclaimer

This note is provided as-is and is subject to change without notice. Except to the extent prohibited by law, dresden elektronik ingenieurtechnik gmbh makes no express or implied warranty of any kind with regard to this guide, and specifically disclaims the implied warranties and conditions of merchantability and fitness for a particular purpose. dresden elektronik ingenieurtechnik gmbh shall not be liable for any errors or incidental or consequential damage in connection with the furnishing, performance or use of this guide.

No part of this publication may be reproduced, stored in a retrieval system, or transmitted in any form or any means electronic or mechanical, including photocopying and recording, for any purpose other



than the purchaser's personal use, without the written permission of dresden elektronik ingenieurtechnik gmbh.

Copyright © 2017 dresden elektronik ingenieurtechnik gmbh. All rights reserved.