



- 1
- 2
- 3
- 4
- 5
- 6
- 7
- 8
- 9
- 10
- 11
- 12
- 13
- 14
- 15
- 16
- 17
- 18

**HANDLE SHANKS**

Glass-fibre reinforced polyamide based (PA) technopolymer, matte finish.

**COVERS**

- ECA.T: Polyamide based (PA) technopolymer, white colour similar to RAL 9002, glossy finish, press-fit assembly. Supplied, removable by a screwdriver.

Available also as accessory sold separately (see table).

**ANTI-ROTATION TUBE ASSEMBLING SYSTEM**

Special expansion-assembly system between the tube and the handle shanks to prevent rotation during operation.

**STANDARD EXECUTION**

Pass-through holes for cylindrical-head screws with hexagon socket, hexagonal-head screws or standard lock nuts.

- Aluminium tube, coating in white colour similar to RAL 9002, glossy finish. Side shanks in white colour similar to RAL 9002.

Suggested tightening torque:

- back mounting with plain holes: 8 [Nm]
- front mounting with plain or tapped holes: 15 [Nm].

**ERGONOMY AND DESIGN**

The large diameter of the tube offers a good and comfortable grip; the antirotation assembly system of the handle shanks to the tube has been developed to offer a firm and secure manoeuvrability during operations.

**TECHNICAL DATA**

Tensile stress: F2 values reported in the table are the result of breaking tests carried out with the appropriate dynamometric equipment under the test conditions shown in the figure with ambient temperature.

**SPECIAL EXECUTIONS ON REQUEST**

Different lengths.

**ACCESSORIES ON REQUEST**

- DS-ETH: ECA.T1-\*
- ECA.T: polyamide based (PA) technopolymer closing caps, white similar to RAL 9002 (CLEAN), glossy finish, press-fit assembly.



ERGOSTYLE® ELESA Original design red dot design award



**ECA.T**

Code	Description	Cover for
29871	ECA.T 1-CLEAN	ETH.28-CLEAN
29872	ECA.T 2-CLEAN	ETH.35-CLEAN

DS-ETH

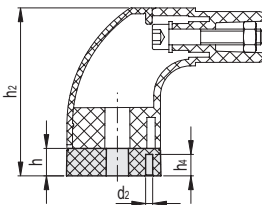

Code	Description	d2	h	h2	h4	For handle	⚖️
15256	DS-ETH.35-16-CLEAN	4	16	101.5	12.5	ETH.35	25
15258	DS-ETH.35-32-CLEAN	4	32.5	118	15	ETH.35	55



Conversion Table			
1 mm = 0,039 inch			
L		d	
mm	inch	mm	inch
339	13.35	10.5	0.41
357	14.05		
439	17.28		
457	18.00		
539	21.22		
557	21.93		
639	25.16		
657	25.87		
739	29.09		
757	29.80		
1057	41.61		

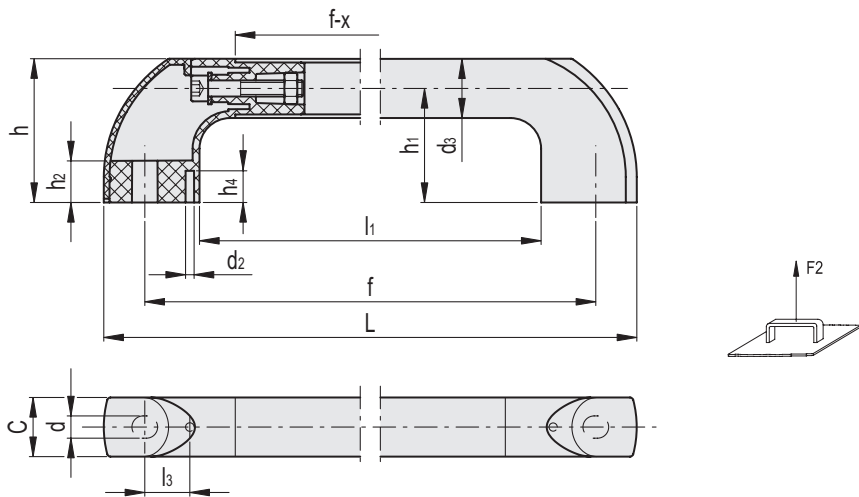

METRIC

Code	Description	d3	fz1	L	d	h	h1	h2	h4	l1	l3	d2	C	x	F2 [N]*	F2 [N]#	⚖️
150911	ETH.28-300-CLEAN	27.5	300	339	10.5	68	54	20	15	248	20.3	4	28	86	2400	2800	235
150913	ETH.28-400-CLEAN	27.5	400	439	10.5	68	54	20	15	348	20.3	4	28	86	2000	2300	268
150915	ETH.28-500-CLEAN	27.5	500	539	10.5	68	54	20	15	448	20.3	4	28	86	1800	2000	301
150917	ETH.28-600-CLEAN	27.5	600	639	10.5	68	54	20	15	548	20.3	4	28	86	1200	1500	335
150919	ETH.28-700-CLEAN	27.5	700	739	10.5	68	54	20	15	648	20.3	4	28	86	900	1200	368
150931	ETH.35-300-CLEAN	34.5	300	357	10.5	85	67.5	28	15	251	18.5	4	35	91	3000	3100	397
150933	ETH.35-400-CLEAN	34.5	400	457	10.5	85	67.5	28	15	351	18.5	4	35	91	2700	2800	456
150935	ETH.35-500-CLEAN	34.5	500	557	10.5	85	67.5	28	15	451	18.5	4	35	91	2500	2600	515
150937	ETH.35-600-CLEAN	34.5	600	657	10.5	85	67.5	28	15	551	18.5	4	35	91	1900	2100	574
150939	ETH.35-700-CLEAN	34.5	700	757	10.5	85	67.5	28	15	651	18.5	4	35	91	1900	2100	633
150941	ETH.35-1000-CLEAN	34.5	1000	1057	10.5	85	67.5	28	15	951	18.5	4	35	91	1200	1400	810

\* Maximum working load  
# Load at breakage