

RECOMMENDED BOARD LAYOUT

SPECIFICATIONS  
 MAKE-BEFORE-BREAK

MATERIALS:  
 ACTUATOR- POM, UL94HB BLACK  
 TERMINAL BOARD- PHENOLIC LAMINATED SHEET, UL94HB, NATURAL  
 FRAME- STEEL, NICKEL PLATE  
 TERMINAL/FIXED CONTACT- COPPER ALLOY, GOLD OR SILVER OVER NICKEL PLATE  
 MOVING CONTACT- COPPER ALLOY, GOLD OR SILVER OVER NICKEL PLATE  
 DETENT BALL- STEEL  
 COIL SPRING- GALVANIZED SPRING WIRE  
 SEAL- EPOXY

ELECTRICAL:  
 CONTACT RATING- .4VA@20VDC OR PEAK AC (GOLD); 300mA@125V AC (SILVER)  
 INITIAL CONTACT RESISTANCE- 30 milliohm max.  
 FINAL CONTACT RESISTANCE- 100 milliohm max. (AFTER TEST)  
 INSULATION RESISTANCE- 1,000 Megohms min.  
 DIELECTRIC STRENGTH- 500V RMS@SEA LEVEL  
 LIFE EXPECTANCY- 15,000 CYCLES MIN.

MECHANICAL:  
 ACTUATION FORCE- 600+/-300 GRAMS  
 TRAVEL- 2.0 +/-0.50 (.079 +/-0.020)

ENVIRONMENTAL:  
 OPERATING TEMPERATURE- -20 TO +85 DEGREES C  
 STORAGE TEMPERATURE- -40 TO +100 DEGREES C  
 RESISTANCE TO SOLDER HEAT PER 109-202, CONDITION B  
 SOLDERABILITY PER EIA-364-52, CLASS 2, CATEGORY 1, 95% MIN COVERAGE

NOTES:

1. COUNTRY OF ORIGIN AND TE LOGO LOCATED APPROXIMATELY AS SHOWN
2. ALL MATERIALS AND FINISHES SHALL COMPLY WITH EU DIRECTIVE 2002/95/EC OF 27JAN2003 (ROHS)
3. ANTI SOLDER WICK SEAL AT TERMINAL TO BOARD INTERFACE
4. ALL PERFORMANCE TESTING WAS DONE IN ACCORDANCE TO TYCO SPECIFICATION 102-2469

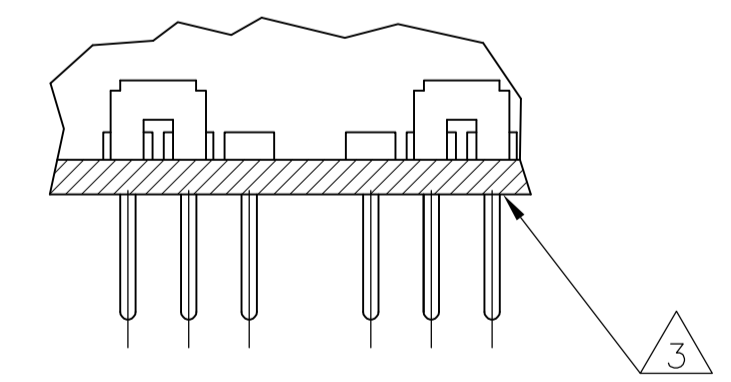

SECTION A-A

1825268-2	MSS4300RG04	GOLD	1 TO 2 5 TO 6 9 TO 10 13 TO 14	2 TO 3 6 TO 7 10 TO 11 14 TO 15	2 TO 4 6 TO 8 10 TO 12 14 TO 16
1825268-1	MSS4300R04	SILVER	1 TO 2 5 TO 6 9 TO 10 13 TO 14	2 TO 3 6 TO 7 10 TO 11 14 TO 15	2 TO 4 6 TO 8 10 TO 12 14 TO 16
TE PART NO.	T&B PART NO.	PLATING			

TERMINALS CONNECTED WHEN SLIDE IS IN POSITION SHOWN.

THIS DRAWING IS A CONTROLLED DOCUMENT.

DIMENSIONS:	TOLERANCES UNLESS OTHERWISE SPECIFIED:	DIN	R BROWN	21DEC05	Tyco Electronics Corporation Harrisburg, Pa 17105-3608
mm	0 PLC ± - 1 PLC ± 0.3 [.012] 2 PLC ± - 3 PLC ± - 4 PLC ± - ANGLES ± -	CHK	M SARVER	21DEC05	
MATERIAL	FINISH	APVD	M SARVER	21DEC05	NAME
					SLIDE SWITCH, MSS 4300R SERIES
		SIZE	CAGE CODE	DRAWING NO	RESTRICTED TO
		WEIGHT	A1	00779	1825268
		CUSTOMER DRAWING	SCALE	4:1	SHEET 1 OF 1 REV A1