

# SPECIFICATION CONTROL DRAWING

THIS DRAWING CONTAINS INFORMATION PROPRIETARY TO RF INDUSTRIES, LTD. ANY UNAUTHORIZED USE OF THIS DRAWING IS EXPRESSLY PROHIBITED. ANY VIOLATION IS PUNISHABLE UNDER U.S. COPYRIGHT LAWS.

REV	DESCRIPTION	DWN	DATE	APPROVED
A	ENGINEERING RELEASE	KMM	2/20/95	R. RICE
B	ENGINEERING RELEASE	CZS	7/15/97	R. RICE
C	CHANGE CONTACT ID / ADD CABLE GROUPS	CZS	9/16/97	R. RICE

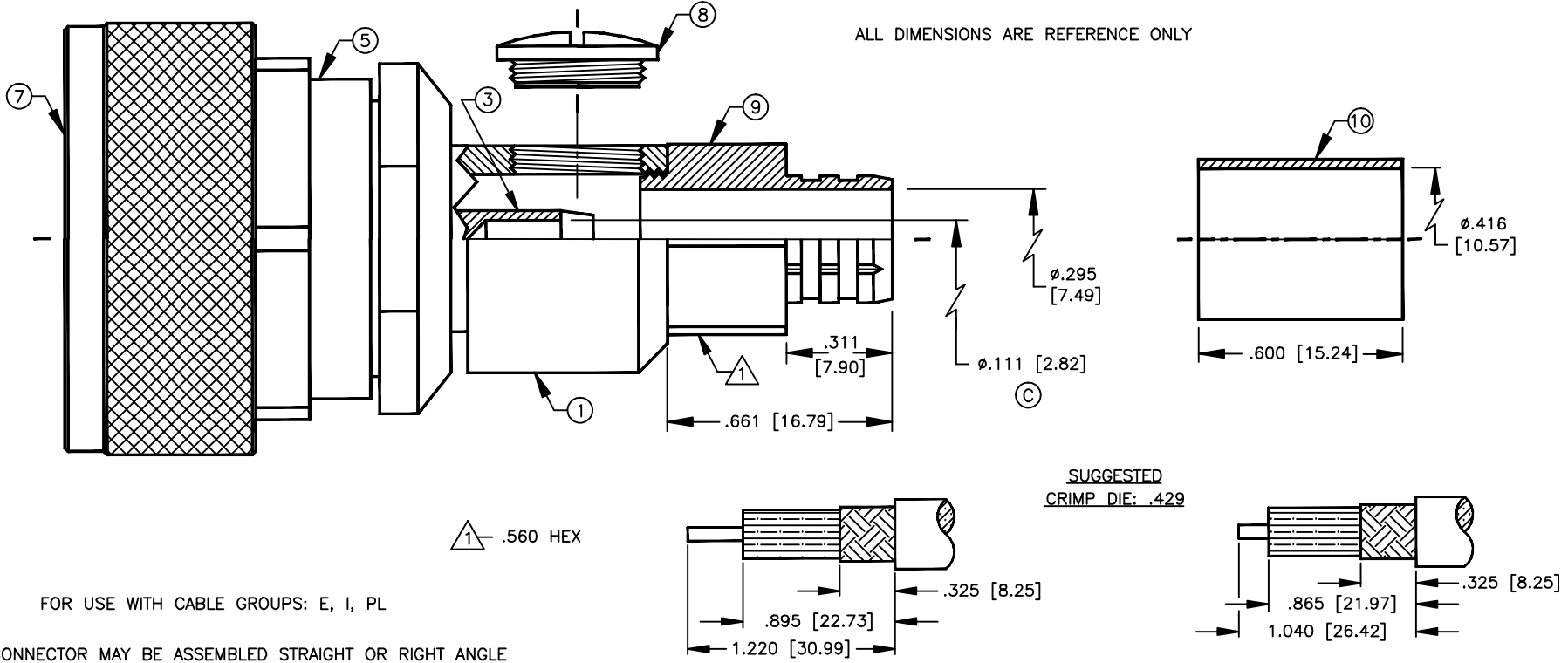

## SPECIFICATIONS:

IMPEDANCE: 50 OHMS

ITEM	DESCRIPTION	PART NUMBER	QTY	MATERIAL	FINISH
10	FERRULE	FER-205	1	BRASS	SILVER
9	BACK NUT	004-XXX0009BE	1	BRASS	SILVER
8	SCREW CAP	020-XXX0001BE	1	BRASS	SILVER
7	SHELL	012-16M0001BE	1	BRASS	SILVER
6	GASKET	GSO-211	1	S.I. RUBBER	RED
5	GROUND RING	014-16M0001BE	1	BRASS	SILVER
4	DIELECTRIC	010-16X0001TX	1	PTFE	NONE
3	CONTACT, CABLE	005-XXX0006BE	1	BRASS	SILVER
2	PIN	009-16M0001BE	1	BRASS	SILVER
1	BODY	001-16X0003BE	1	BRASS	SILVER

DIMENSIONS ARE IN INCHES AND [MILLIMETERS]	
UNLESS OTHERWISE NOTED TOLERANCES ARE:	
DECIMALS	DIAMETER
DRAWN C. ZUNIGA	9/16/97
CHECKED	
ORJ DRAWN K. MAXWELL	2/20/95
APPROVALS	DATE

7610 MIRAMAR RD  
SAN DIEGO, CA 92126  
(858)549-6340  
(858)549-6345 FAX

# RF connectors

DIVISION OF RF INDUSTRIES, LTD.

## RFD-1605-2-E

7/16 DIN MALE CRIMP

SIZE A	CABLE GROUP E, I, PL	DWG NO. 8440	REV C
SCALE: NT		CAD FILE 13ARC B	SHEET 1 OF 1