

## Harvatek Surface Mount PLCC IC+RGB LEDs Data Sheet T3A33BRG-H9C0002X1U1930

Official Product	HT Part No.T3A33BRG-H9C0002X1U1930		
Tentative Product	*****	*****	*****
Specifications are subject to changes for improvement without advance notice. Proprietary data, drawings, company confidential all rights reserved.		1/14/2022	Version 1.0 Page 1/18

<b>DISCLAIMER</b> .....	<b>3</b>
<b>LIFE SUPPORT POLICY</b> .....	<b>3</b>
<b>PRODUCT SPECIFICATIONS</b> .....	<b>4</b>
<b>ATTENTION: ELECTROSTATIC DISCHARGE (ESD) PROTECTION</b> .....	<b>4</b>
<b>LABEL SPECIFICATIONS</b> .....	<b>5</b>
<b>PRODUCT FEATURES</b> .....	<b>6</b>
<b>PACKAGE OUTLINE DIMENSION AND RECOMMENDED SOLDERING PATTERN FOR REFLOW</b>	
<b>SOLDERING</b> .....	<b>6</b>
<b>ABSOLUTE MAXIMUM RATINGS</b> .....	<b>7</b>
<b>ELECTRICAL CHARACTERISTICS</b> .....	<b>7</b>
<b>PRECAUTION FOR USE</b> .....	<b>12</b>
<b>PACKAGING</b> .....	<b>13</b>
<b>TAPE DIMENSION</b> .....	<b>13</b>
<b>REEL</b> .....	<b>14</b>
<b>DIMENSION</b> .....	<b>14</b>
<b>PACKING</b> .....	<b>14</b>
<b>DRY PACK</b> .....	<b>15</b>
<b>BAKING</b> .....	<b>15</b>
<b>PRECAUTIONS</b> .....	<b>15</b>
<b>HANDLING OF SILICONE RESIN LEADS</b> .....	<b>16</b>
<b>REFLOW SOLDERING</b> .....	<b>17</b>
<b>REWORKING</b> .....	<b>17</b>
<b>CLEANING</b> .....	<b>17</b>
<b>CAUTIONS OF PICK AND PLACE</b> .....	<b>17</b>
<b>REVISE HISTORY</b> .....	<b>18</b>

Official Product	HT Part No.T3A33BRG-H9C0002X1U1930		
Tentative Product	*****	*****	
Specifications are subject to changes for improvement without advance notice. Proprietary data, drawings, company confidential all rights reserved.		1/14/2022	Version 1.0 Page 2/18

## DISCLAIMER

HARVATEK reserves the right to make changes without further notice to any products herein to improve reliability, function or design. HARVATEK does not assume any liability arising out of the application or use of any product or circuit described herein; neither does it convey any license under its patent rights, nor the rights of others.

## Life Support Policy

HARVATEK's products are not authorized for use as critical components in life support devices or systems without the express written approval of the President of HARVATEK or HARVATEK INTERNATIONAL. As used herein:

1. Life support devices or systems are devices or systems which, (a) are intended for surgical implant into the body, or (b) support or sustain life, and (c) whose failure to perform when properly used in accordance with instructions for use provided in the labeling, can be reasonably expected to result in a significant injury of the user.
2. A critical component in any component of a life support device or system whose failure to perform can be reasonably expected to cause the failure of the life support device or system, or to affect its safety or effectiveness.

Official Product	HT Part No.T3A33BRG-H9C0002X1U1930		
Tentative Product	*****	*****	*****
Specifications are subject to changes for improvement without advance notice. Proprietary data, drawings, company confidential all rights reserved.		1/14/2022	Version 1.0 Page 3/18

## Product Specifications

Item	Specification	Material	Quantity
Luminous Intensity (Iv)	R:560.0-1125.0 mcd G:1125.0-2850.0 mcd B:285.0-715.0 mcd IC@5V T <sub>s</sub> = 25°C;Tolerance: ± 10%		
Dominant Wavelength (Wd)	R:615.0-630.0 nm G:515.0-535.0 nm B:460.0-476.0 nm IC@5V T <sub>s</sub> = 25°C;Tolerance: ± 1 nm		
Applied voltage	5V_DC		
Resin	Clear	Silicone	
Carrier tape	EIA 481-1A specs	Conductive black tape	1000
Reel	EIA 481-1A specs	Conductive black	
Label	HT standard	Paper	
Packing bag	220x240mm	Aluminum laminated bag/ no-zipper	One reel per bag
Carton	HT standard	Paper	Non-specified

**Others:**

Each immediate box consists of 5 reels. The 5 reels may not necessarily have the same lot number or the same bin combinations of Iv, λ<sub>D</sub> and Vf. Each reel has a label identifying its specification; the immediate box consists of a product label as well.

Note :This is shipped test conditions

※Remarks: This product should be operated in forward bias. If a reverse voltage is continuously applied to the product, such operation can cause migration resulting in LED damage.

**ATTENTION: Electrostatic Discharge (ESD) protection**



The symbol to the left denotes that ESD precaution is needed. ESD protection for GaP and AlGaAs based chips is necessary even though they are relatively safe in the presence of low static-electric discharge. Parts built with AlInGaP, GaN, or/and InGaN based chips are **STATIC SENSITIVE devices**. ESD precaution must be taken during design and assembly.

If manual work or processing is needed, please ensure the device is adequately protected from ESD during the process.

Official Product	HT Part No.T3A33BRG-H9C0002X1U1930		
Tentative Product	*****	*****	
Specifications are subject to changes for improvement without advance notice. Proprietary data, drawings, company confidential all rights reserved.	1/14/2022	Version 1.0	Page 4/18

## Label Specifications

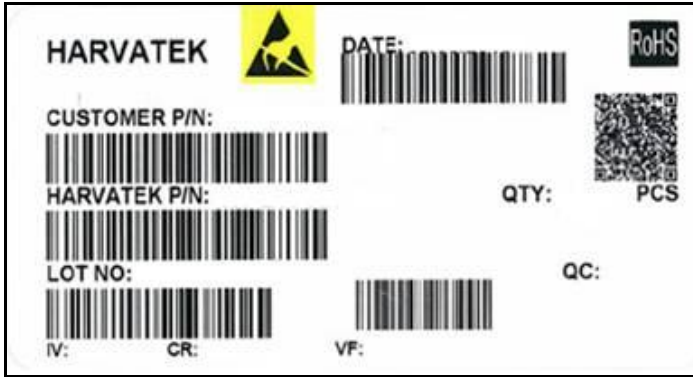

### Harvatek P/N:

**T 3A3 3 BRG- H9C- 0002 X1 U1930**

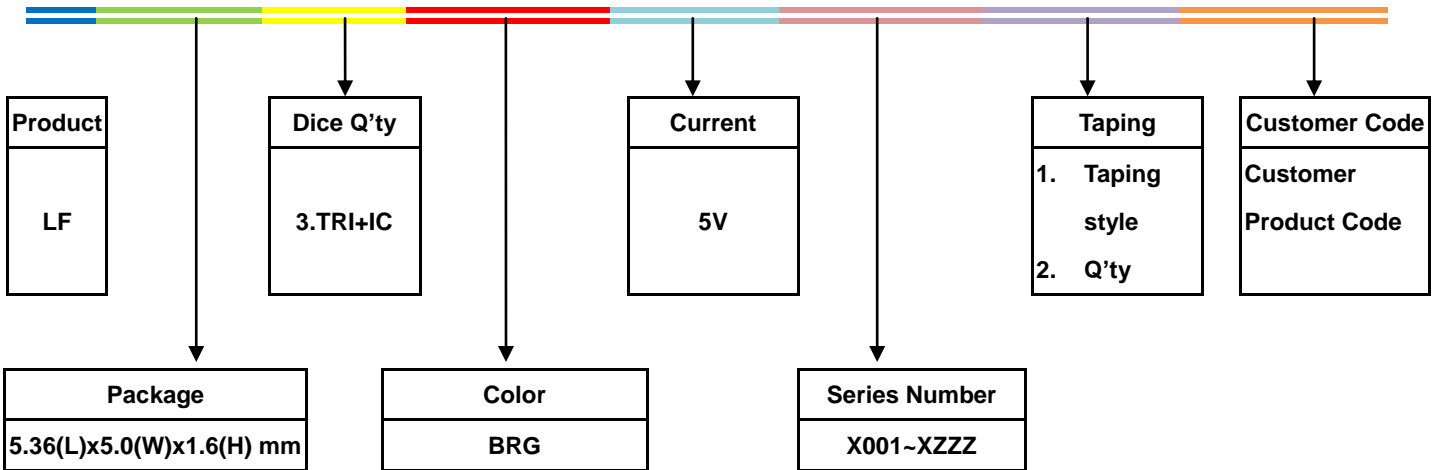

### Lot No.:

1	2	3	4	5	6	7	8	9	10
E	1	A	1	A	2	2	L	1	2
Code 1 2		Code 3	Code 4	Code 5	Code 6	Code 7	Code 8	Code 9	Code 10
		Mfg. Year	Mfg. Month	Mfg. Date	Consecutive number		Special code		
Internal Tracing Code		2010-A		1:A	01~ZZ		000~ZZZ		
		2011-B		2:B					
		2012-C	1:Jan.	3:C					
		...	2:Feb.	...					
		2018-I/J	...	26:Z					
		2019-K	A:Oct.	27:7					
		...	B:Nov.	28:8					
2022-N	C:Dec.	29:9							
2023-P		30:3							
...		31:4							

Official Product	HT Part No. T3A33BRG-H9C0002X1U1930		
Tentative Product	*****	*****	*****
Specifications are subject to changes for improvement without advance notice. Proprietary data, drawings, company confidential all rights reserved.	1/14/2022	Version 1.0	Page 5/18

## Product Features

### Electro-Optical Characteristics

(T<sub>Soldering</sub> , 25 °C)

Series	Emitting Color	Material	Wavelength λ(nm)			I <sub>v</sub> (mcd)	Viewing
			λ <sub>D</sub>	λ <sub>P</sub>	Δλ	Typical	Angle $2\theta \frac{1}{2}$
T3A33BRG	B	InGaN	470	465	25	400	120
	R	AlInGaP	624	630	18	800	120
	G	InGaN	523	518	35	1800	120

### Package Outline Dimension and Recommended Soldering Pattern for Reflow Soldering

(Unit:mm Tolerance: +/-0.1)

Outline Dim.

The diagram shows three views of the package: a top view, a side view, and a bottom view. The top view shows a square package with a diameter of 5.00 ± 0.2 mm and a central circular area with a diameter of 4.30 mm. The pins are labeled: Pin 6 (GND), Pin 5 (CIN), Pin 4 (DIN) on the top edge; Pin 1 (VDD), Pin 2 (COUT), Pin 3 (DOUT) on the bottom edge. The side view shows a height of 1.60 mm. The bottom view shows the lead frame and plastic housing, with dimensions for the pin spacing: 0.70 mm between Pin 4 and Pin 5, 0.90 mm between Pin 5 and Pin 6, and 0.90 mm between Pin 3 and Pin 2. The soldering pattern shows the recommended dimensions for the solder pads: Pin 6 (1.30 mm width), Pin 5 (1.30 mm width), Pin 4 (1.30 mm width), Pin 1 (1.30 mm width), Pin 2 (1.30 mm width), Pin 3 (1.30 mm width). The overall width of the soldering pattern is 4.10 mm, and the height is 3.62 mm. The distance between the center of Pin 4 and Pin 1 is 0.70 mm, and the distance between the center of Pin 3 and Pin 2 is 0.90 mm.

Soldering Pattern

Soldering terminals may shift in the Wd direction.

Official Product	HT Part No. T3A33BRG-H9C0002X1U1930		
Tentative Product	*****	*****	*****
Specifications are subject to changes for improvement without advance notice. Proprietary data, drawings, company confidential all rights reserved.	1/14/2022	Version 1.0	Page 6/18

## Absolute Maximum Ratings

(TA=25°C)

Symbol	Parameter	Range	Units
V <sub>DD</sub>	Supply Voltage	6.5	V
P <sub>D</sub>	Power Dissipation	<400	mW
I <sub>LEDOUT</sub>	Maximum Output Current	30	mA
T <sub>M</sub>	Welding Temperature	300(8S)	°C
T <sub>OPR</sub>	Operating Temperature Range	-40~+85	°C
T <sub>STO</sub>	Storage Temperature Range	-65+125	°C

## Electrical characteristics

(unless otherwise specified, Temperature=25°C & V<sub>DD</sub>=5.0V)

Symbol	Characteristic	Min.	Typ.	Max.	Units	Condition
V <sub>DD</sub>	Supply Voltage	3.3	5.0	5.5	V	-
I <sub>dyn</sub>	Operation Current	-	-	2	mA	V <sub>DD</sub> =5V, RGB off
I <sub>sleep</sub>	Standby Current	-	-	5	μA	-
<b>Logic input control DIN/CIN</b>						
V <sub>IH</sub>	Input High "H"	2.7	-	V <sub>DD</sub> +0.4	V	-
V <sub>IL</sub>	Input High "L"	-0.4	-	1.0	V	-
R <sub>IN</sub>	DIN Pull-up resistance @normal mode	-	80k	-	Ω	-
C <sub>FREQ</sub>	CIN Frequency	-	-	15	MHz	-
T <sub>CKH</sub>	CIN High pulse width	30	-	-	ns	-
T <sub>CKL</sub>	CIN Low pulse width	30	-	-	ns	-
T <sub>SETUP</sub>	DIN to CIN setup	10	-	-	ns	-
T <sub>HOLD</sub>	DIN to CIN hold time	5	-	-	ns	-
<b>Logic output DOUT/COUT</b>						
V <sub>OH</sub>	Output High "H"	4.5	-	-	V	4mA@V <sub>DD</sub> =5V
V <sub>OL</sub>	Output High "L"	-	-	0.4	V	4mA@V <sub>DD</sub> =5V
<b>Sink Current R/G/B</b>						
I <sub>SINK</sub>	Sink Current	19	20	21	mA	@V <sub>DD</sub> -V <sub>fLED</sub> ≥1.5V

Official Product	HT Part No.T3A33BRG-H9C0002X1U1930		
Tentative Product	*****	*****	*****
Specifications are subject to changes for improvement without advance notice. Proprietary data, drawings, company confidential all rights reserved.		1/14/2022	Version 1.0 Page 7/18

■ Application circuit

Block Diagram

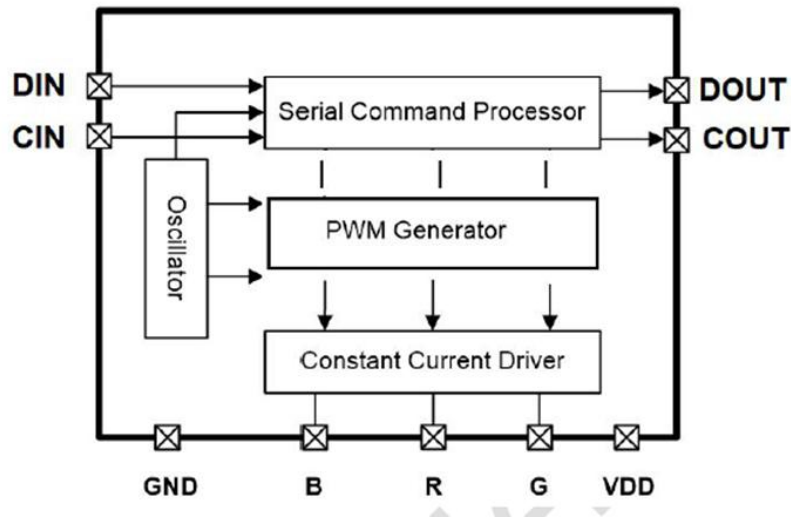

Pin Function Description

Pin Name	IO	Description
VDD	P	Power Supply
GND	G	Ground
DIN	I	Series data input
DOUT	I	Series data output
CIN	O	Clock input
COUT	O	Clock output
R	O	Red LED output driver
G	O	Green LED output driver
B	O	Blue LED output driver

Official Product	HT Part No. T3A33BRG-H9C0002X1U1930		
Tentative Product	*****	*****	*****
Specifications are subject to changes for improvement without advance notice. Proprietary data, drawings, company confidential all rights reserved.		1/14/2022	Version 1.0 Page 8/18



## ■ Cascading data structure

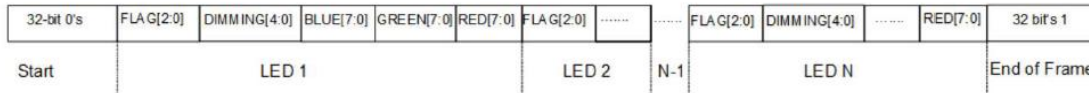

32 consecutive 0's denote the start of a command for an RGB LED. After receiving 32 0's, IC gets the following 32 bits as the received command, including FLAG, DIMMING, BLUE, GREEN and RED fields.

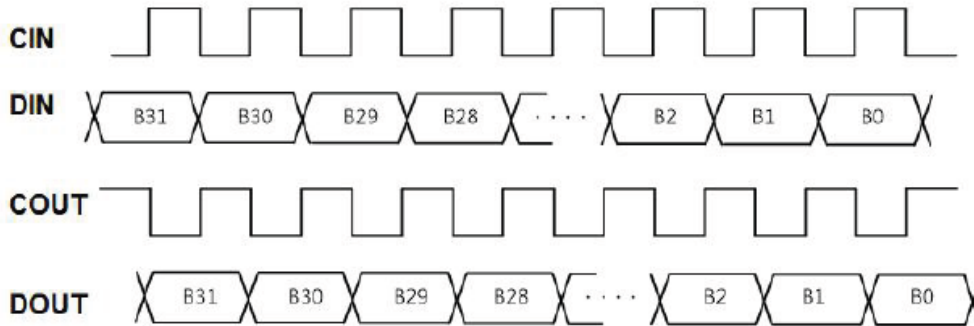

The serial command is transmitted with MSB first, DIN is latched at the rising edge of CIN clock. COUT and DOUT are re-generated for the next RGB LED. COUT is inverted from CIN. When 32 consecutive 0's are encountered, the next 1 is expected to start a 32-bit command, i.e., FLAG [2:0]=111. When FLAG [2:0]=111, then DIMMING, BLUE, GREEN and RED fields are latched respectively. While the current 32-bit command is got, IC passes remaining command bits to the next RGB LED.

After the last one command is issued for the last LED (LED n), the following 32 consecutive 1's denote the end of the current command for an RGB LED(End of Frame) and wait for next 32 consecutive 0's to start a new command set.(Note: IC is workable either with or without "End of Frame" command, but MCU should issue the extra N/2 numbers of clocks signal if there are N LED lamps totally connected in the strip to make sure the data transfer and display of the last one LED lamp is complete and correct)

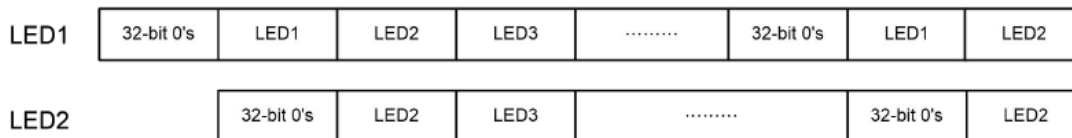

Official Product	HT Part No.T3A33BRG-H9C0002X1U1930		
Tentative Product	*****	*****	*****
Specifications are subject to changes for improvement without advance notice. Proprietary data, drawings, company confidential all rights reserved.	1/14/2022	Version 1.0	Page 9/18

- FLAG [2:0]** : 111 to start a 32-bit command
- DIMMING [4:0]** : 32-level current control for R/G/B drivers
- BLUE [7:0]** : 256 gray levels for blue LED
- GREEN [7:0]** : 256 gray levels for green LED
- RED [7:0]** : 256 gray levels for red LED

## Sleep and power saving mode

IC supports the sleep/wake-up modes for power-saving purpose. In sleep mode, the built-in oscillator and associated circuitry will be disabled. The quiescent current of IC is approximately 1uA (typ.).

## Command Setup to enable sleep or wake up mode

When receiving 24-bit 0's BGR data (that is BLUE [7:0]=8h00, G [7:0]=8h00, R [7:0]=8h00), in the meantime, both of the data in 3-bits' flag and 5-bits' DIMMING is 8h'A0' (that is FLAG [2:0]=3b101 and DIMMING [4:0]=5b00000), IC will enter sleep mode.

IC will wake up from sleep mode once receiving the new data with the data of Flag [2:0], DIMMING [4:0] is not 8h"A0"; after wake-up, all sleeping circuits in IC return to normal working mode within 1ms. Since it takes 1ms for a sleeping IC returning to normal function mode, it is recommended for a host to wait for 1ms to send display data and command after issuing a wake-up command.

Sleep power-saving mode example:

32 bits 0	Flag[2:0]=3'b101	Dimming[4]=5'b00000	Blue[8'h00]	Green[8'h00]	Red[8'h00]	Sleep mode
-----------	------------------	---------------------	-------------	--------------	------------	------------

Official Product	HT Part No.T3A33BRG-H9C0002X1U1930				
Tentative Product	*****	*****			*****
Specifications are subject to changes for improvement without advance notice. Proprietary data, drawings, company confidential all rights reserved.		1/14/2022	Version 1.0	Page 10/18	

**Case 1:**

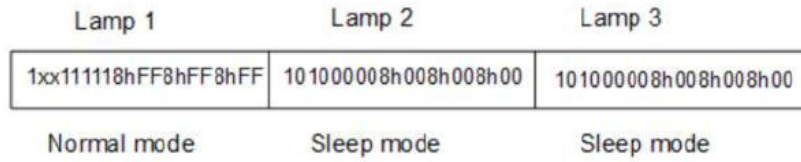

**Case 2:**

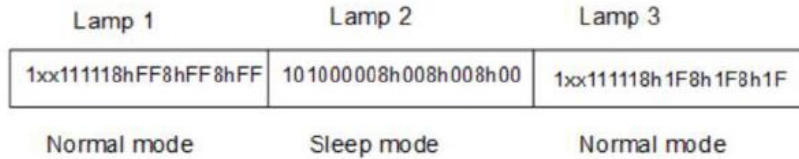

In case 2, while lamp2 is under sleep mode, in the following data transfer process, the state of lamp 2 will be not changed as long as the 32 bits data for lamp 2 is received with data of Flag [2:0]·DIMMING [4:0] being 8h"A0". It means lamp2 will keep in sleep mode as well. In the situation, lamp2 can pass through the remaining data to lamp 3 (32bits) to change the display data of lamp 3. In other words, the sleeping chip is able to pass the data to the next chips.

**Typical Circuit of an RGB LED strip application**

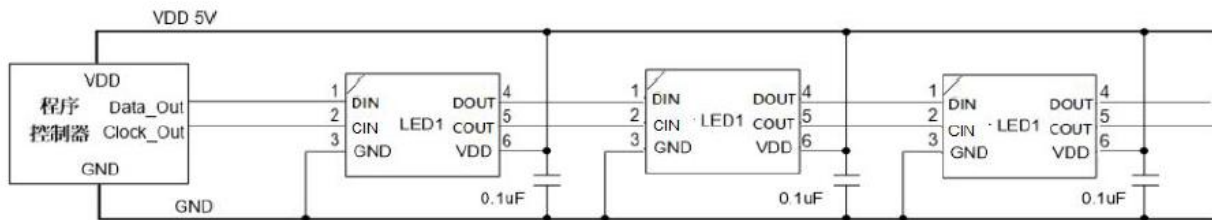

Official Product	HT Part No.T3A33BRG-H9C0002X1U1930		
Tentative Product	*****	*****	*****
Specifications are subject to changes for improvement without advance notice. Proprietary data, drawings, company confidential all rights reserved.	1/14/2022	Version 1.0	Page 11/18

### Precaution for Use

1. The chips should not be used directly in any type of fluid such as water, oil, organic solvent, etc.
2. When the LEDs are illuminating, the maximum ambient temperature should be first considered before operation.
3. LEDs must be stored in a clean environment. A sealed container with a nitrogen atmosphere is necessary if the storage period is over 3 months after shipping.
4. The LEDs must be used within 24 hrs after unpacked. Unused products must be repacked in an anti-electrostatic package, folded to close any opening and then stored in a dry and cool space.
5. The appearance and specifications of the products may be modified for improvement without further notice.
6. The LEDs are sensitive to the static electricity and surge. It is strongly recommended to use a grounded wrist band and anti-electrostatic glove when handling the LEDs. If a voltage over the absolute maximum rating is applied to LEDs, it will damage LEDs. Damaged LEDs will show some abnormal characteristics such as remarkable increase of leak current, lower turn-on voltage and getting unlit at low current.

Official Product	HT Part No. T3A33BRG-H9C0002X1U1930		
Tentative Product	*****	*****	*****
Specifications are subject to changes for improvement without advance notice. Proprietary data, drawings, company confidential all rights reserved.		1/14/2022	Version 1.0 Page 12/18

## Packaging Tape Dimension

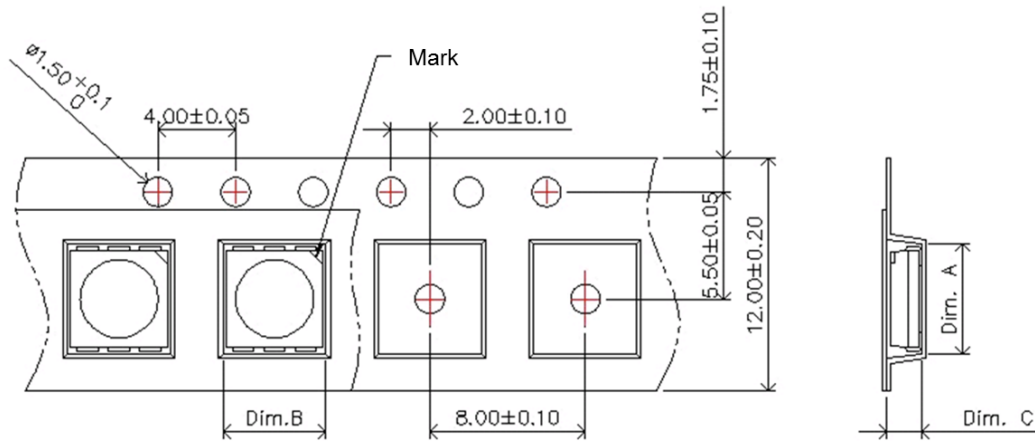

Dim. A	Dim. B	Dim. C	Q'ty/Reel
5.70 ± 0.10	5.30 ± 0.10	1.80 ± 0.10	1000

Unit : mm

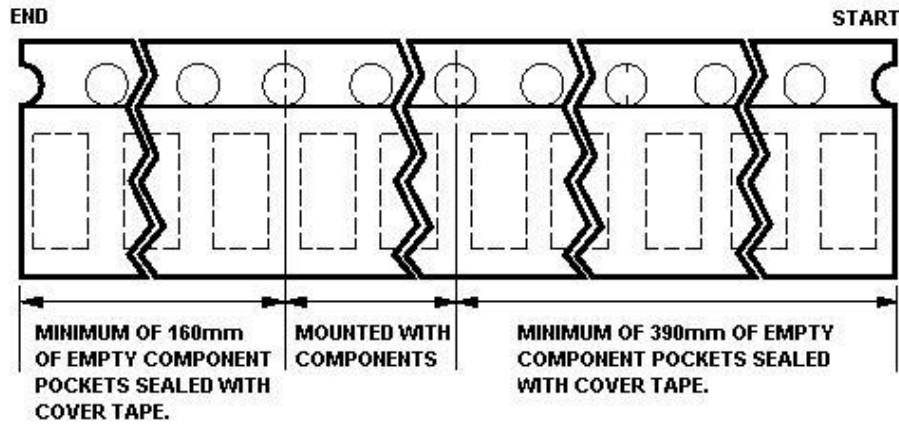

Official Product	HT Part No. T3A33BRG-H9C0002X1U1930		
Tentative Product	*****	*****	*****
Specifications are subject to changes for improvement without advance notice. Proprietary data, drawings, company confidential all rights reserved.		1/14/2022	Version 1.0 Page 13/18

## Reel Dimension

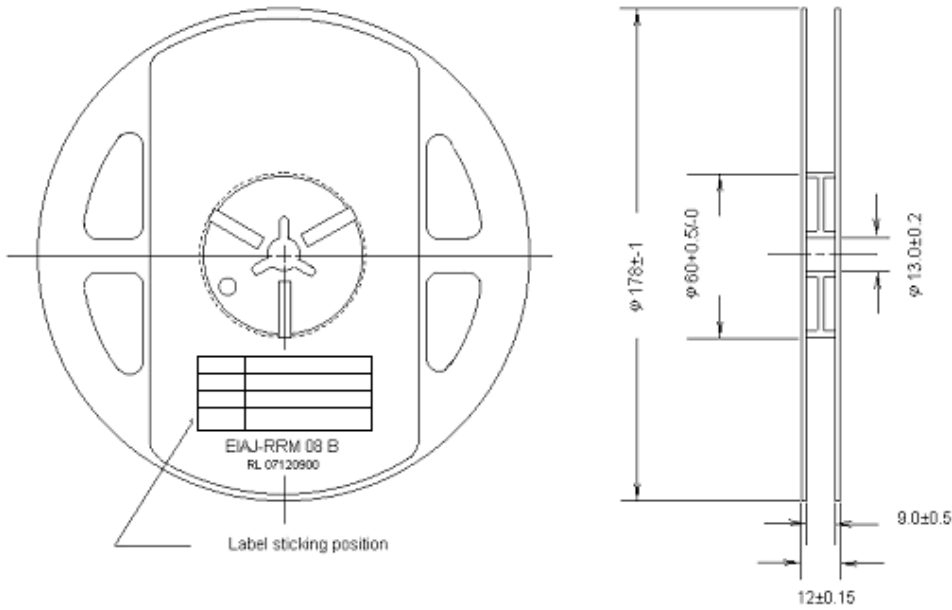

Unit : mm

## Packing

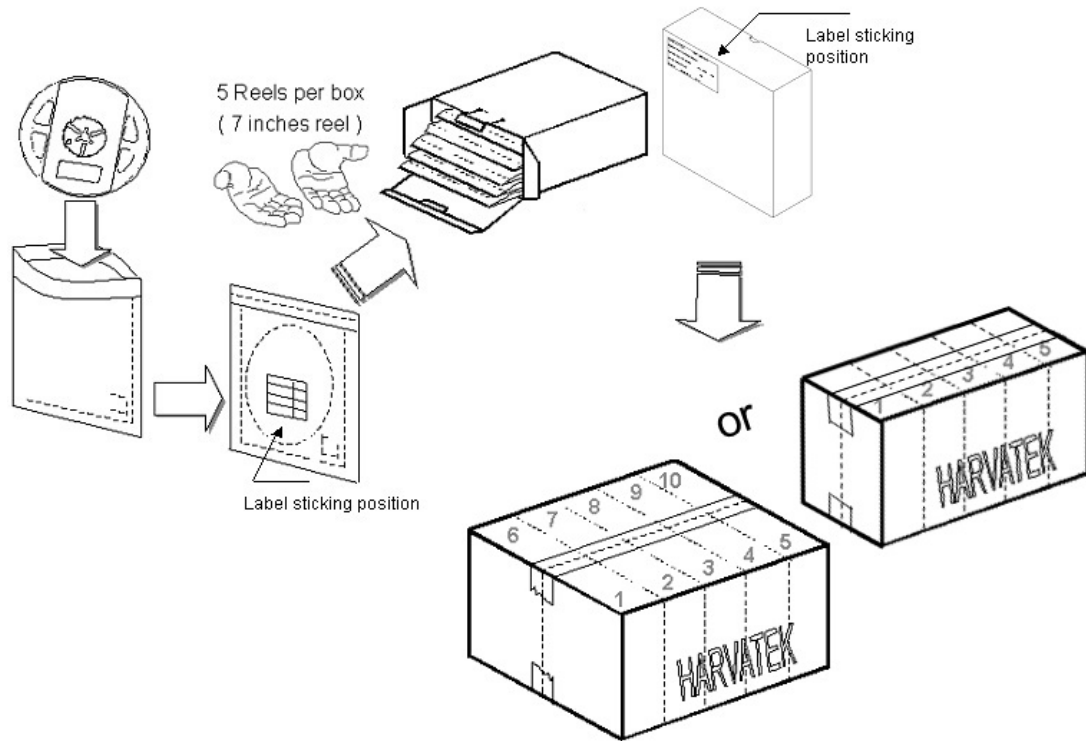

5 or 10 boxes per carton is available depending on shipment quantity.

Official Product	HT Part No. T3A33BRG-H9C0002X1U1930		
Tentative Product	*****	*****	
Specifications are subject to changes for improvement without advance notice. Proprietary data, drawings, company confidential all rights reserved.	1/14/2022	Version 1.0	Page 14/18

**Dry Pack**

All SMD optical devices are **MOISTURE SENSITIVE**. Avoid exposure to moisture at all times during transportation or storage. Every reel is packaged in a moisture protected anti-static bag. Each bag is properly sealed prior to shipment.

Upon request, a humidity indicator will be included in the moisture protected anti-static bag prior to shipment.

The packaging sequence is as follows:

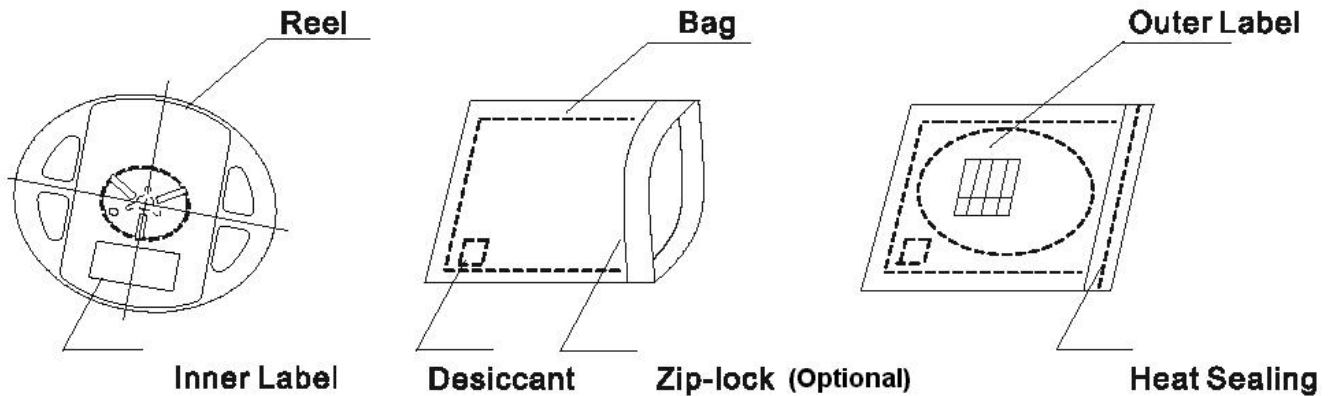

**Baking**

Baking before soldering is recommended when the package has been unsealed for 72 hrs.

The conditions are as followings:

1.  $60\pm3^{\circ}\text{C} \times (12\sim 24\text{hrs})$  and  $<5\%RH$ , taped reel type.
2.  $100\pm3^{\circ}\text{C} \times (45\text{min}\sim 1\text{hr})$ , bulk type.
3.  $130\pm3^{\circ}\text{C} \times (15\text{min}\sim 30\text{min})$ , bulk type.

**Precautions**

1. Avoid exposure to moisture at all times during transportation or storage.
2. Anti-Static precaution must be taken when handling GaN, InGaN, and AlInGaP products.
3. It is suggested to connect the unit with a current limiting resistor of the proper size. Avoid applying a reverse voltage beyond the specified limit.
4. Avoid operation beyond the limits as specified by the absolute maximum ratings.
5. Avoid direct contact with the surface through which the LED emits light.
6. If possible, assemble the unit in a clean room or dust-free environment.

Official Product	HT Part No. T3A33BRG-H9C0002X1U1930		
Tentative Product	*****	*****	*****
Specifications are subject to changes for improvement without advance notice. Proprietary data, drawings, company confidential all rights reserved.	1/14/2022	Version 1.0	Page 15/18

**Handling of Silicone Resin LEDs**

Handling Indications

During processing, mechanical stress on the surface should be minimized as much as possible.

Sharp objects of all types should not be used to pierce the sealing compound.



Figure 1

In general, LEDs should only be handled from the side. By the way ,this also applies to LEDs without a silicone sealant, since the surface can also become scratched.

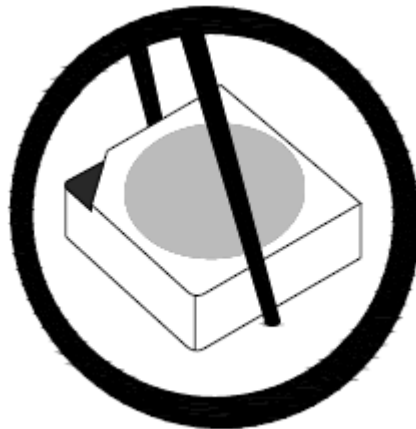

Figure 2

When populating boards in SMT production, there are basically no restrictions regarding the from of the pick and place nozzle, except that mechanical pressure on the surface of the resin must be prevented.

This is assured by choosing a pick and place nozzle which is large than LEDs reflector area.

Official Product	HT Part No.T3A33BRG-H9C0002X1U1930		
Tentative Product	*****	*****	*****
Specifications are subject to changes for improvement without advance notice. Proprietary data, drawings, company confidential all rights reserved.		1/14/2022	Version 1.0 Page 16/18



**Reflow Soldering**

Recommend soldering paste specifications:

1. Operating temp.: Above 217 °C ,60~150 sec.
2. Peak temp.:260 °CMax.,10sec Max.
3. Reflow soldering should not be done more than two times.
4. Never attempt next process until the component is cooled down to room temperature after reflow.
5. The recommended reflow soldering profile (measured on the surface of the LED terminal) is as following:

Lead-free Solder Profile

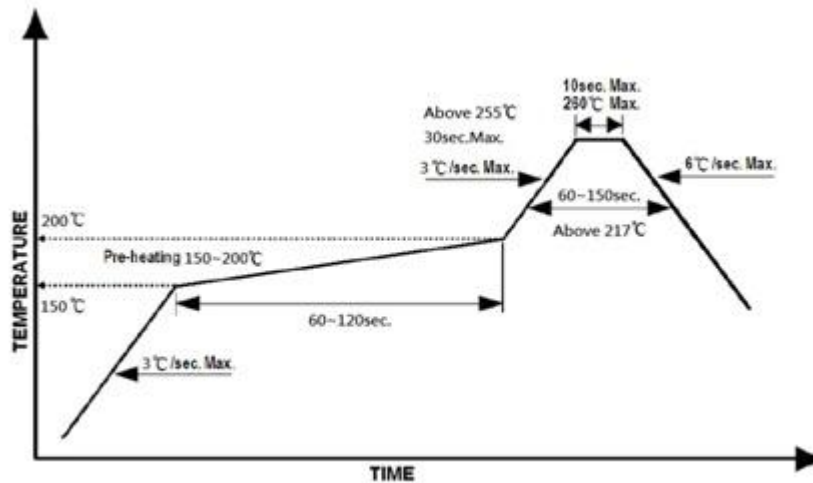

**Reworking**

- Rework should be completed within 5 seconds under 260 °C.
- The iron tip must not come in contact with the copper foil.
- Twin-head type is preferred.

**Cleaning**

Following are cleaning procedures after soldering:

- An alcohol-based solvent such as isopropyl alcohol (IPA) is recommended.
- Temperature x Time should be 50°C x 30sec. or <30°C x 3min
- Ultrasonic cleaning: < 15W/ bath; bath volume ≤ 1liter
- Curing: 100 °C max, <3min

Cautions of Pick and Place

- Avoid stress on the resin at elevated temperature.

Official Product	HT Part No.T3A33BRG-H9C0002X1U1930		
Tentative Product	*****	*****	*****
Specifications are subject to changes for improvement without advance notice. Proprietary data, drawings, company confidential all rights reserved.	1/14/2022	Version 1.0	Page 17/18

- Avoid rubbing or scraping the resin by any object.
- Electric-static may cause damage to the component. Please ensure that the equipment is properly grounded. Use of an ionizer fan is recommended.
- 

### Revise History

Rev.	Descriptions	Date	Page
1.0	New Format	1/14/2022	-