

# VC.253 | Shortened lobe knobs

Duroplast

# VC.254 | Lobe knobs

Duroplast



## MATERIAL

Phenolic based (PF) Duroplast, black colour, glossy finish.

## STANDARD EXECUTION

Black-oxide steel boss, threaded pass-through hole.

## MATERIAL

Phenolic based (PF) Duroplast, black colour, glossy finish.

## STANDARD EXECUTION

Brass boss, threaded pass-through hole and large metal locking face.

## CONFORMITY

UNI 6960-71 type B with pass-through hole.



ELESA Original design



ELESA Original design

Conversion Table	
1 mm = 0.039 inch	
D	
mm	inch
40	1.57
50	1.97
60	2.36
70	2.76
85	3.35

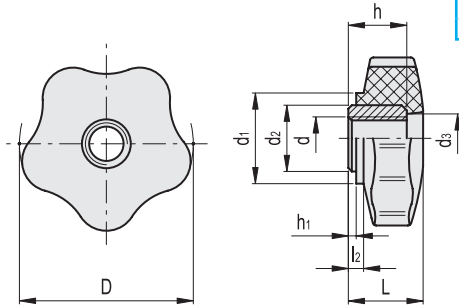

METRIC

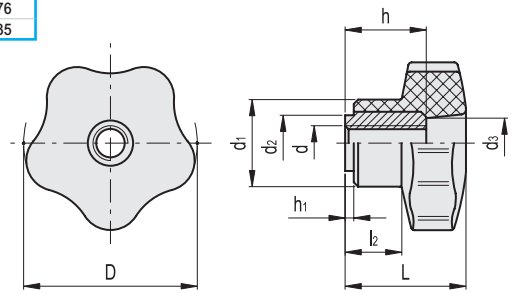

METRIC

Code	Description	D	d6H	L	d1	d2	d3	l2	h	h1	Δ
66951	VC.253/40 A-M8	40	M8	19	23	17	14	3	15	1.5	38
67001	VC.253/40 A-M10	40	M10	19	23	17	14	3	15	1.5	34
67011	VC.253/40 A-M12	40	M12	19	23	17	14	3	15	1.5	30
67101	VC.253/50 A-M12	50	M12	21	26	19	14	3	16	1.5	50
67201	VC.253/60 A-M12	60	M12	24	30	19	16	4	16	1.5	75
67301	VC.253/85 A-M14	85	M14	30	32	18	18	6	22	1.5	135

Code	Description	D	d6H	L	d1	d2	d3	l2	h	h1	Δ
67501	VC.254/40 B-M6	40	M6	28	21	14	13	13	18	1.5	42
67511	VC.254/40 B-M8	40	M8	28	21	14	13	13	18	1.5	38
67521	VC.254/40 B-M10	40	M10	28	21	14	13	13	18	1.5	34
67601	VC.254/50 B-M10	50	M10	34	25	16	13	15	22	1.5	62
67611	VC.254/50 B-M12	50	M12	34	25	16	13	15	22	1.5	55
67701	VC.254/60 B-M10	60	M10	38	27	17	15	18	26	1.5	97
67711	VC.254/60 B-M12	60	M12	38	27	17	15	18	26	1.5	90
67721	VC.254/60 B-M14	60	M14	38	27	17	15	18	26	1.5	85
67801	VC.254/70 B-M12	70	M12	45	30	17	17	21	26	1.5	125
67811	VC.254/70 B-M14	70	M14	45	30	17	17	21	26	1.5	115
67901	VC.254/85 B-M16	85	M16	56	35	24	18	32	35	2	210