

## SUMMARY

### # Wires

Triax 1



*Image is for illustrative purpose only*

Series	0S
Termination type	Female print PCB
IP rating	50
AWG wire size	0.00 - 0.00
Cable Ø	0.00 - 0.00 mm
Status	active
Matching parts	<a href="#">FFA.0S.650.CLAC17</a>

### Download

- [Request a quote](#)
- [PCB Eagle Pattern](#)
- [PCB Altium Pattern](#)
- [PCB KiCad Pattern](#)
- [Catalog](#)

## TECHNICAL DETAILS

### Mechanics

Shell Style/Model	EPL*: Elbow receptacle for printed circuit
Keying	Circular, female
Housing Material	Brass (nickel plated [SAE AMS QQ N 290]) collet and crimping tube, brass (chrome plated [SAE AMS 2460]) collet nut
Weight	8.02 g

### Performance

Configuration	0S.650 : 1 Triax (50 Ohm)
Insulator	T: PTFE
Rated Current	6 Amps

### Specifications

Test Voltage(kV rms) 1.2  
Cable type: RGT 178, RGT 174

### Others

Endurance (Shell): 5000 mating cycles  
Temp (min / max): -55°C / +250°C  
Humidity (max): <=95% [at 60 deg C / 140 F]

*LEMO products and services are provided "as is". LEMO makes no warranties or representations with regard to LEMO product & services or use of them, express, implied or statutory, including for accuracy, completeness, or security. The user is fully responsible for his products and applications using LEMO components.*

Vibration: 15 g [10 Hz - 2000 Hz]  
 Shock Resistance: 100 g [ 6 ms]  
 Climatical Category: 50/175/21  
 Shielding (min): 75 dB (10 MHz)  
 Shielding (min): 40 dB (1 GHz)  
 Salt Spray Corrosion: >144 hr

## DRAWINGS

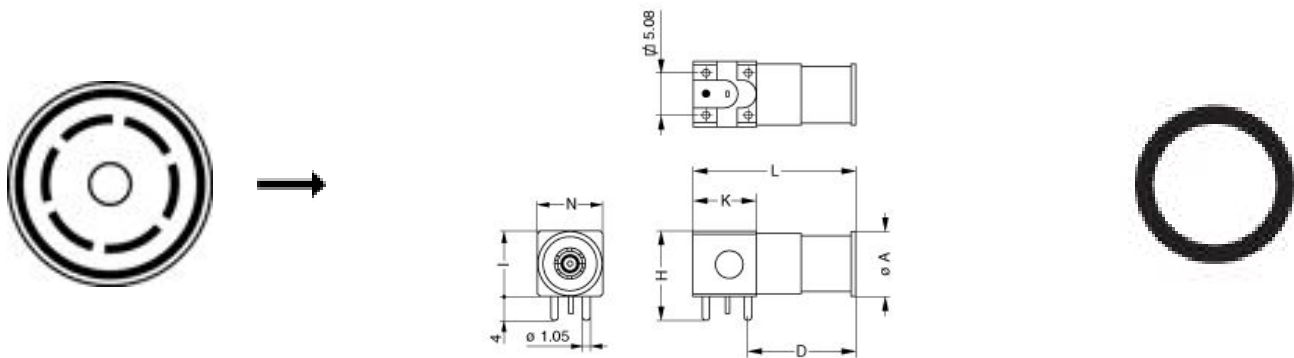

### Dimensions

	A	H	I	L	N	d
mm.	8.8	13	9	23.6	9	5.08
in.	0,35	0,51	0,35	0,93	0,35	0,20

## RECOMMENDED BY LEMO

### Tools

Spanner wrench: [Socket for torque wrench DCM.05.M09.4](#)

*LEMO products and services are provided "as is". LEMO makes no warranties or representations with regard to LEMO product & services or use of them, express, implied or statutory, including for accuracy, completeness, or security. The user is fully responsible for his products and applications using LEMO components.*