



# APPLICATION SPECIFICATION

## SQUBA 3.6

### INTERCONNECT SYSTEMS



REVISION: <b>B</b>	ECM INFORMATION: EC No: <b>732935</b> DATE: <b>2022/12/22</b>	TITLE: <b>APPLICATION SPECIFICATION SQUBA 3.6 INTERCONNECT SYSTEM</b>	SHEET No. <b>1 of 14</b>
DOCUMENT NUMBER: <b>2077760000-AS</b>	DOC TYPE: <b>PS</b>	DOC PART: <b>000</b>	CREATED / REVISED BY: <b>VENKAS5</b>
		CHECKED BY: <b>VENKAS5</b>	APPROVED BY: <b>MRAMAKRISHNA</b>

**1.0 SCOPE**

This Application Specification covers the application and end-usage requirements for the Squba 3.6 Sealed Wire-To-Wire, 3.60mm pitch single row connector series which uses copper terminals with tin plated contact interface terminated with 16, 18 and 20 AWG wire using Molex crimp technology. The mated system meets IP68 requirements.

**2.0 PRODUCT DESCRIPTION****2.1 NAMES AND SERIES NUMBER(S)**

Description	Series Number
Squba 3.6 Receptacle Assembly	207782
Squba 3.6 Plug Assembly	207778
Squba 3.6 Receptacle Crimp Terminal	207777
Squba 3.6 Plug Crimp Terminal	207776
Squba Plug Weather Cap	220423
Squba receptacle Weather cap	220424

**2.2 DIMENSIONS, MATERIALS, PLATINGS AND MARKINGS**

See the appropriate sales drawings for the information on dimensions, materials, platings and markings.

REVISION: <b>B</b>	ECM INFORMATION: EC No: <b>732935</b> DATE: <b>2022/12/22</b>	TITLE: <b>APPLICATION SPECIFICATION SQUBA 3.6 INTERCONNECT SYSTEM</b>	SHEET No. <b>2 of 14</b>		
DOCUMENT NUMBER: <b>2077760000-AS</b>	DOC TYPE: <b>PS</b>	DOC PART: <b>000</b>	CREATED / REVISED BY: <b>VENKAS5</b>	CHECKED BY: <b>VENKAS5</b>	APPROVED BY: <b>MRAMAKRISHNA</b>

### 3.0 APPLICABLE DOCUMENTS AND SPECIFICATIONS

Product Specification.....	2077760000-PS
Receptacle Assembly sales drawing.....	2077820000-SD
Plug Assembly sales drawing.....	2077780000-SD
Receptacle Crimp Terminal sales drawing.....	2077770000-SD
Plug Crimp Terminal sales drawing.....	2077760000-SD
Plug weather Cap sales drawing.....	2204230000-SD
Receptacle Weather Cap sales drawing.....	2204240000-SD
Test Summary.....	2077760000-TS
Receptacle Assembly Packaging Specification.....	2077820000-PK
Plug Assembly Packaging Specification.....	2077780000-PK
Receptacle Crimp Terminal Packaging Specification.....	2077770000-PK
Plug Crimp Terminal Packaging Specification.....	2077760000-PK
Plug weather Cap Packaging Specification .....	2204230000-PK
Receptacle Weather Cap Packaging Specification .....	2204240000-PK
Applicator Tool Crimp Specification.....	Refer table under section 4.2
Hand Tool Crimp Specification.....	Refer table under section 4.2

### 4.0 PRODUCT DEFINITION

#### 4.1 CONNECTOR ASSEMBLIES (4 CKT CONNECTORS SHOWN)

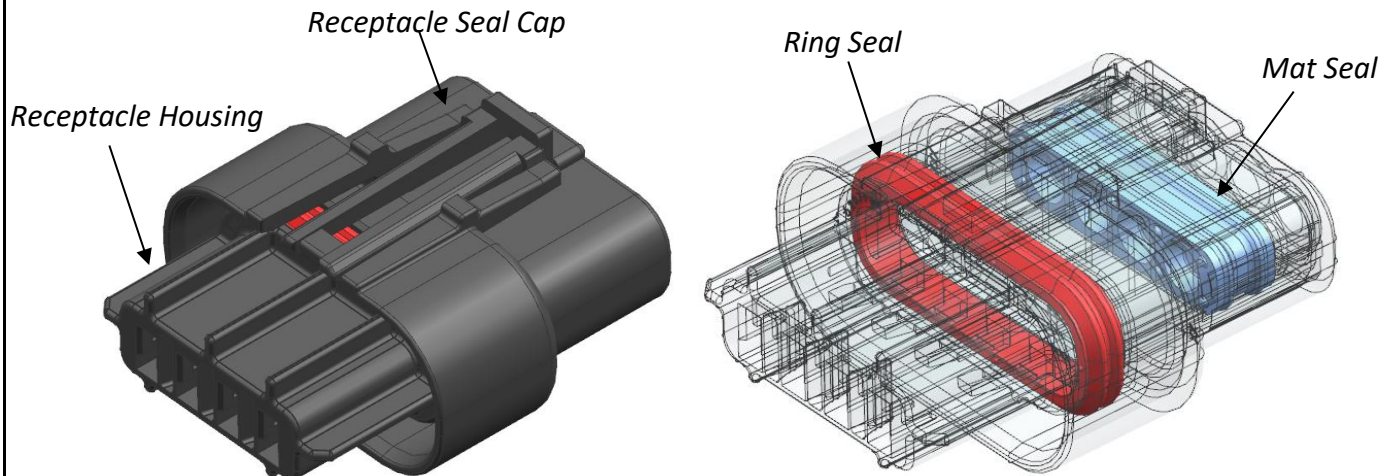

REVISION: <b>B</b>	ECM INFORMATION: EC No: <b>732935</b> DATE: <b>2022/12/22</b>	TITLE: <b>APPLICATION SPECIFICATION SQUBA 3.6 INTERCONNECT SYSTEM</b>	SHEET No. <b>3 of 14</b>
DOCUMENT NUMBER: <b>2077760000-AS</b>	DOC TYPE: <b>PS</b>	DOC PART: <b>000</b>	CREATED / REVISED BY: <b>VENKAS5</b>
		CHECKED BY: <b>VENKAS5</b>	APPROVED BY: <b>MRAMAKRISHNA</b>

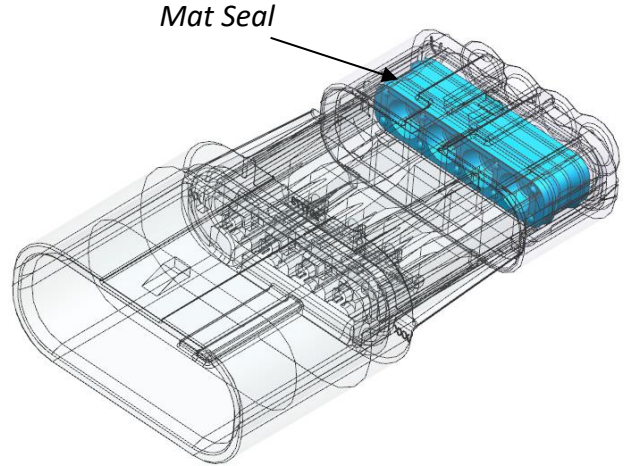
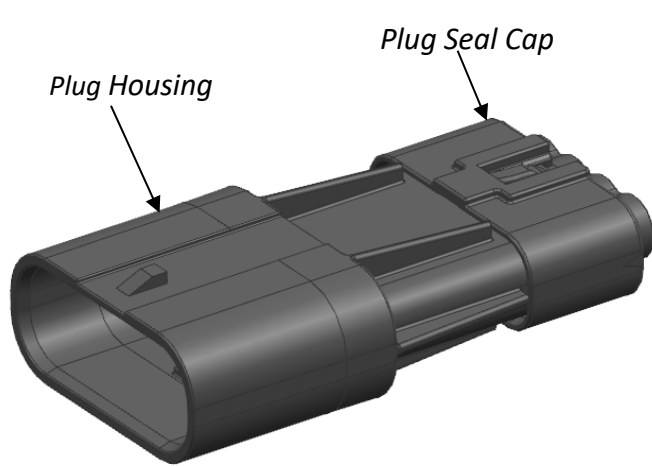

## 4.2 CRIMP TERMINALS

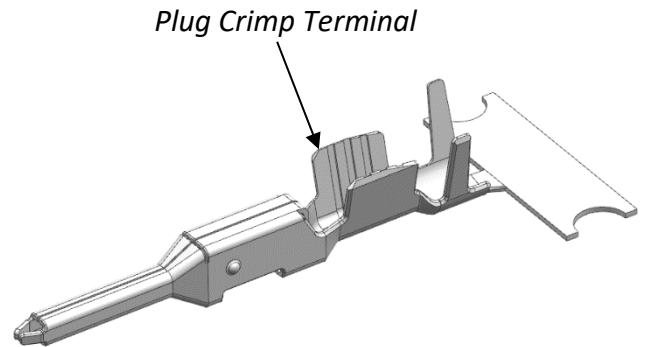
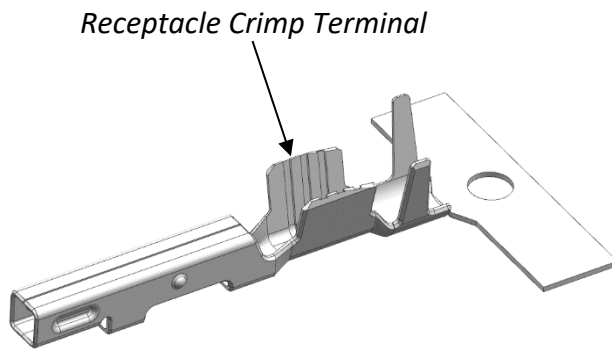

Crimp Tools	Description	Wire Style	Order Number	Crimp Spec Document Number
Crimp Hand Tools	16 AWG Male & Female Terminal	UL 1007/1061	2133090000	2133090000
	18 AWG Male & Female Terminal	UL 1007/1061	2133090100	2133090100
	20 AWG Male & Female Terminal	UL 1007/1061	2133090200	2133090200
Crimp Applicators	16 AWG Female Terminal	UL 1007/1061	2130690600	2130690600
	16 AWG Male Terminal	UL 1007/1061	2130690700	2130690700
	18-20 AWG Female Terminal	UL 1007/1061	2130690800	2130690800
	18-20 AWG Male Terminal	UL 1007/1061	2130690900	2130690900
	18-20 AWG Female Terminal	UL 1015/1230	2130695000	2130695000
	18-20 AWG Male Terminal	UL 1015/1230	2130694900	2130694900

REVISION: <b>B</b>	ECM INFORMATION: EC No: <b>732935</b> DATE: <b>2022/12/22</b>	TITLE: <b>APPLICATION SPECIFICATION SQUBA 3.6 INTERCONNECT SYSTEM</b>	SHEET No. <b>4 of 14</b>
DOCUMENT NUMBER: <b>2077760000-AS</b>	DOC TYPE: <b>PS</b>	DOC PART: <b>000</b>	CREATED / REVISED BY: <b>VENKAS5</b>
		CHECKED BY: <b>VENKAS5</b>	APPROVED BY: <b>MRAMAKRISHNA</b>

**Crimp Applicator**

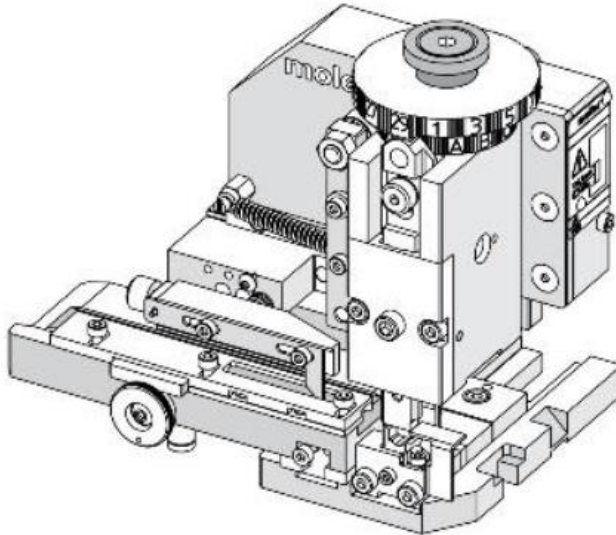

**Hand Tool**

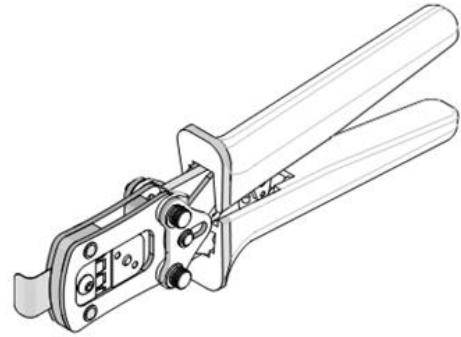

### 4.3 WEATHER CAPS

*Plug Weather Cap*



*Receptacle weather cap*

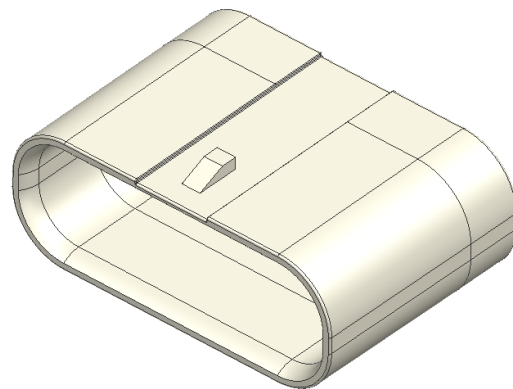

REVISION: <b>B</b>	ECM INFORMATION: EC No: <b>732935</b> DATE: <b>2022/12/22</b>	TITLE: <b>APPLICATION SPECIFICATION SQUBA 3.6 INTERCONNECT SYSTEM</b>	SHEET No. <b>5 of 14</b>
DOCUMENT NUMBER: <b>2077760000-AS</b>	DOC TYPE: <b>PS</b>	DOC PART: <b>000</b>	CREATED / REVISED BY: <b>VENKAS5</b>
		CHECKED BY: <b>VENKAS5</b>	APPROVED BY: <b>MRAMAKRISHNA</b>

## 5.0 TERMINAL ORIENTATION DURING INSERTION INTO HOUSING

Terminals are to be inserted in the housings as shown below on sheet 5-8. Notice the orientation of the terminal body relative to the receptacle thumb latch and plug thumb latch hook. Notice the orientation of the terminal body relative to the “U” marking in the housings. Do not force terminals into the housing cavity. The terminal and housing are designed with silicon seals and other features that will provide some light resistance during insertion as well as retention after insertion but if excessive resistance is felt during insertion pull terminal back out and double check that the terminal orientation per sheets 5-8. Terminals are to be inserted until they are fully seated and audible click is heard. The housing provides a stopping surface and the housing lock finger provides terminal retention and a light audible click to indicate a fully inserted terminal. You can use the PUSH → CLICK → PULL method (sheet 10) during terminal insertion to ensure fully seated terminal.

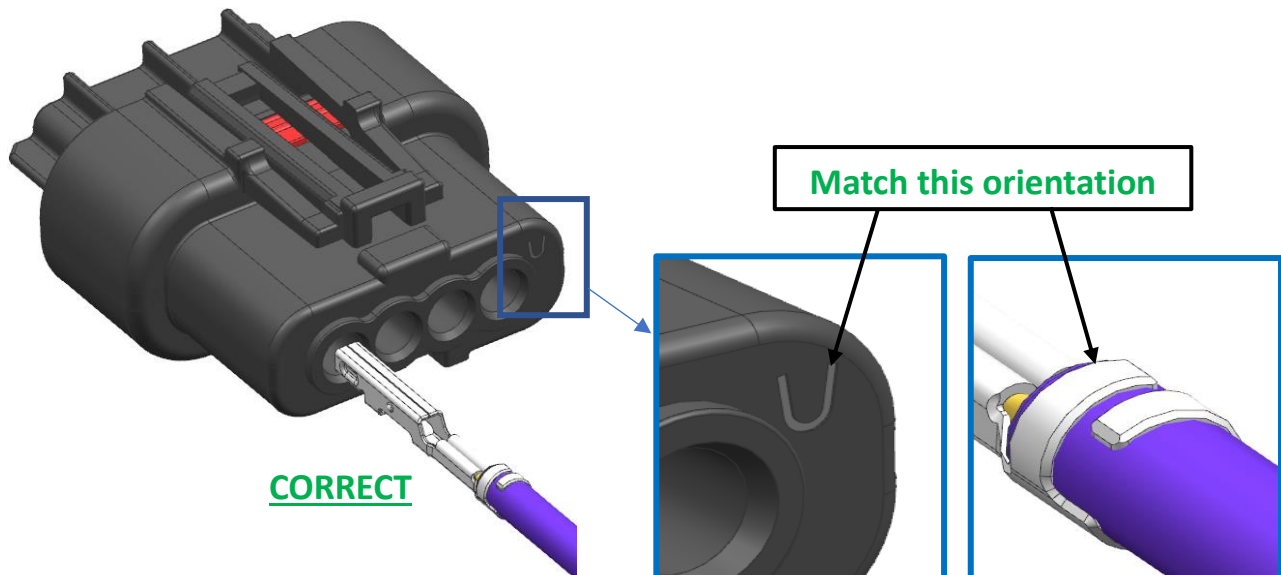
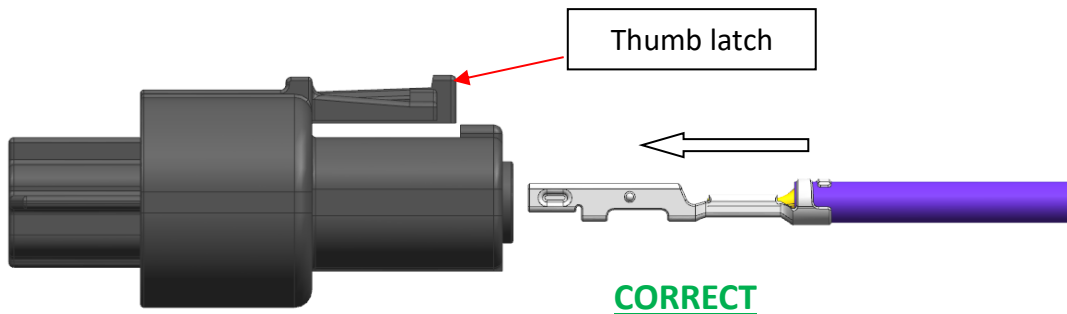

REVISION: <b>B</b>	ECM INFORMATION: EC No: <b>732935</b> DATE: <b>2022/12/22</b>	TITLE: <b>APPLICATION SPECIFICATION SQUBA 3.6 INTERCONNECT SYSTEM</b>	SHEET No. <b>6 of 14</b>
DOCUMENT NUMBER: <b>2077760000-AS</b>	DOC TYPE: <b>PS</b>	DOC PART: <b>000</b>	CREATED / REVISED BY: <b>VENKAS5</b>
		CHECKED BY: <b>VENKAS5</b>	APPROVED BY: <b>MRAMAKRISHNA</b>

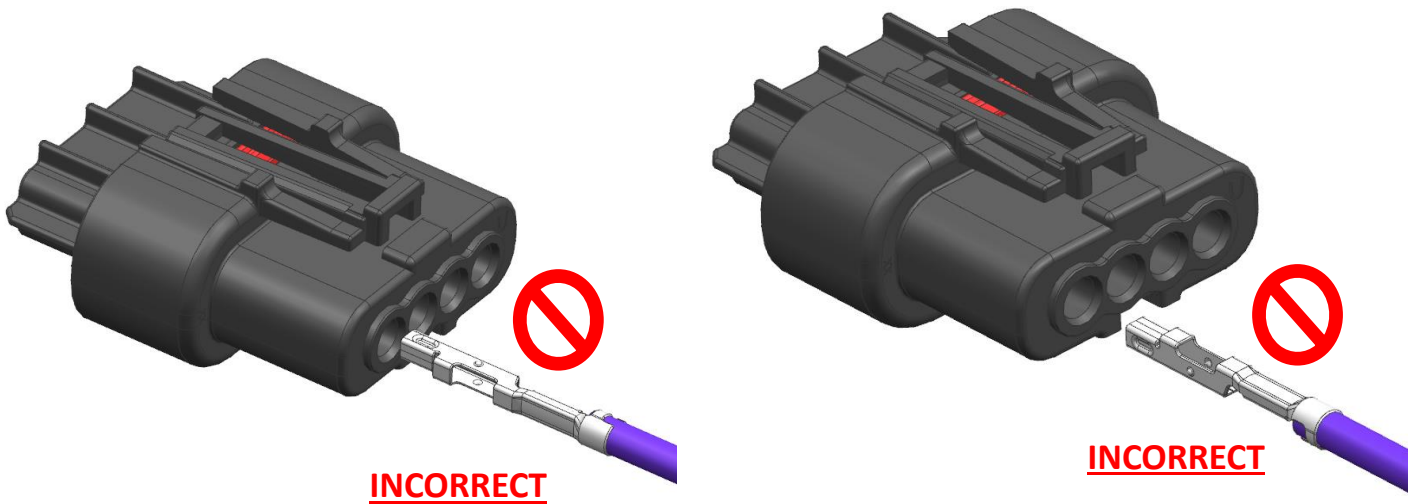
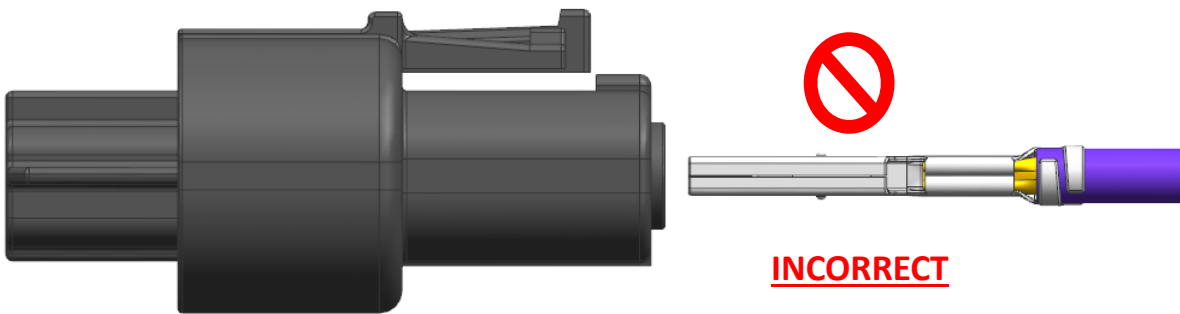
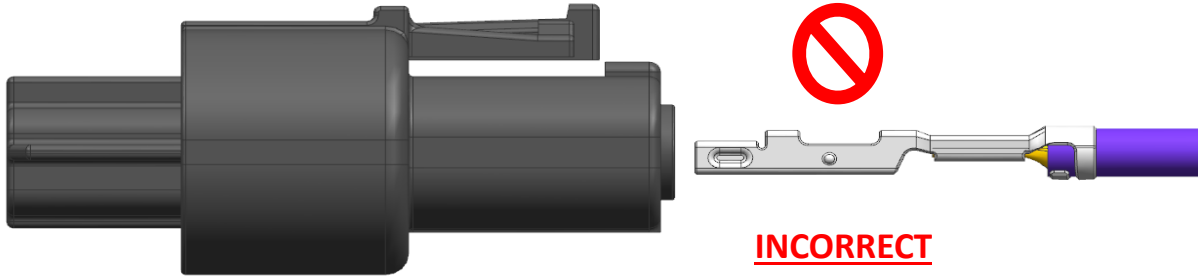

REVISION: <b>B</b>	ECM INFORMATION: EC No: <b>732935</b> DATE: <b>2022/12/22</b>	TITLE: <b>APPLICATION SPECIFICATION SQUBA 3.6 INTERCONNECT SYSTEM</b>	SHEET No. <b>7 of 14</b>
DOCUMENT NUMBER: <b>2077760000-AS</b>	DOC TYPE: <b>PS</b>	DOC PART: <b>000</b>	CREATED / REVISED BY: <b>VENKAS5</b>
		CHECKED BY: <b>VENKAS5</b>	APPROVED BY: <b>MRAMAKRISHNA</b>

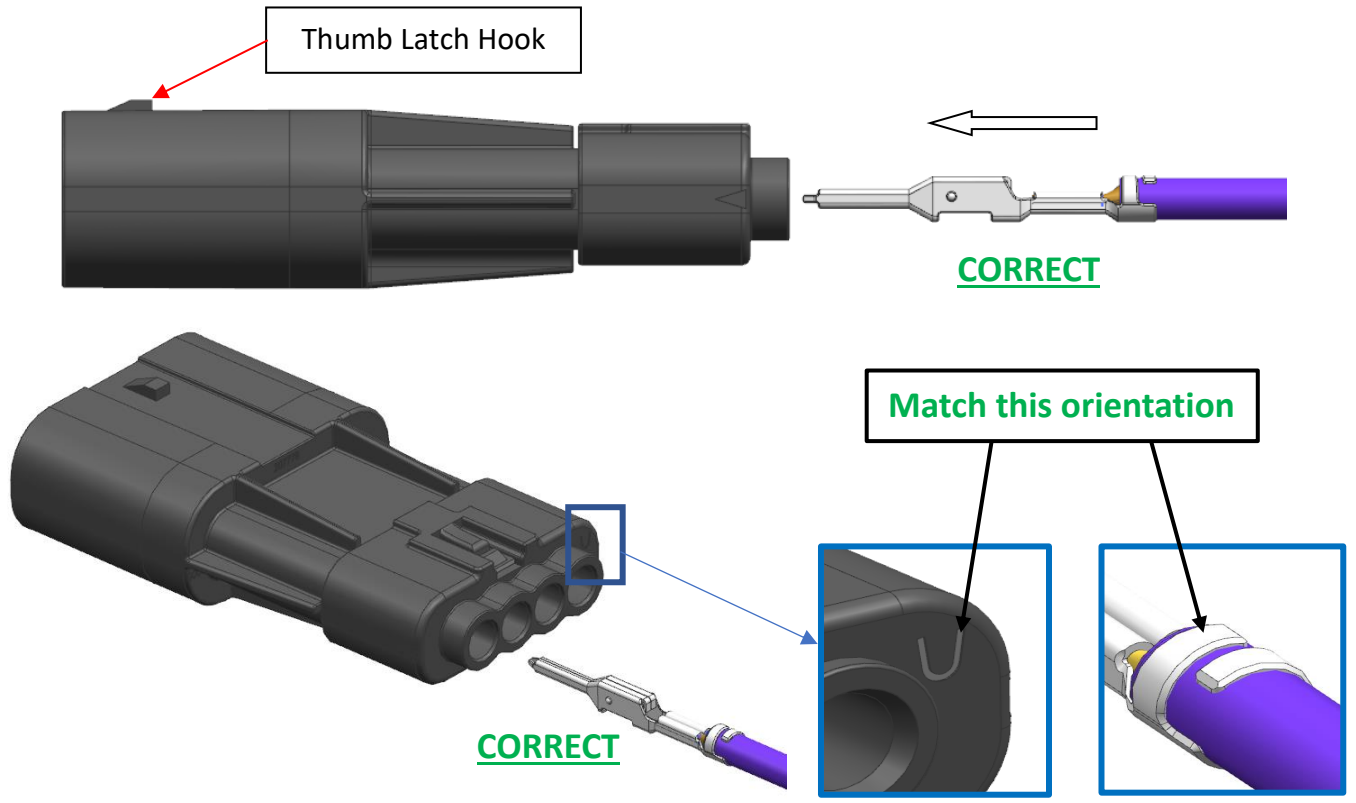

### INSERTION SKEW

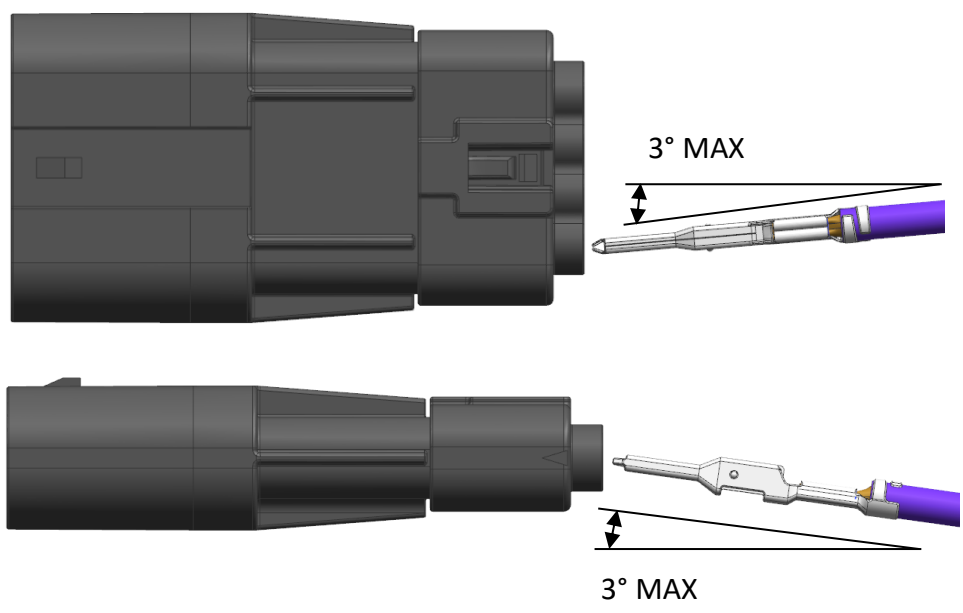

REVISION: <b>B</b>	ECM INFORMATION: EC No: 732935 DATE: 2022/12/22	TITLE: <b>APPLICATION SPECIFICATION SQUBA 3.6 INTERCONNECT SYSTEM</b>	SHEET No. <b>8 of 14</b>
DOCUMENT NUMBER: <b>2077760000-AS</b>	DOC TYPE: <b>PS</b>	DOC PART: <b>000</b>	CREATED / REVISED BY: <b>VENKAS5</b>
		CHECKED BY: <b>VENKAS5</b>	APPROVED BY: <b>MRAMAKRISHNA</b>



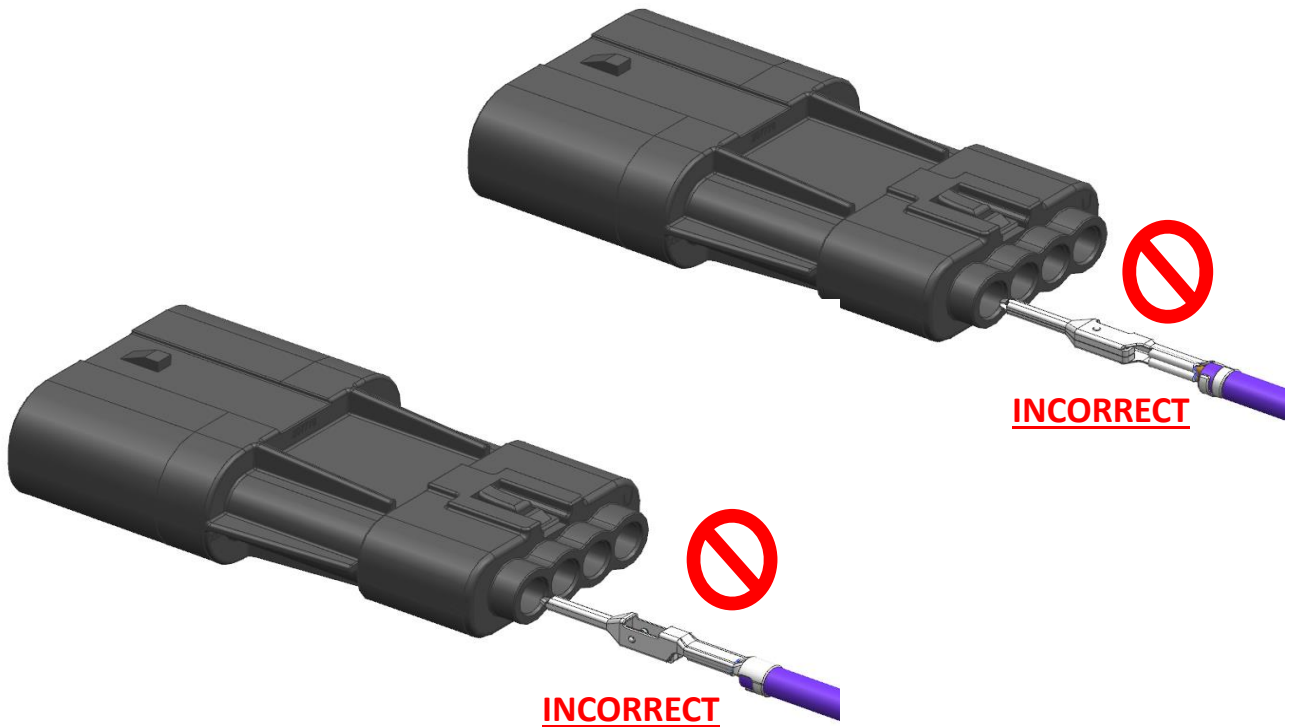
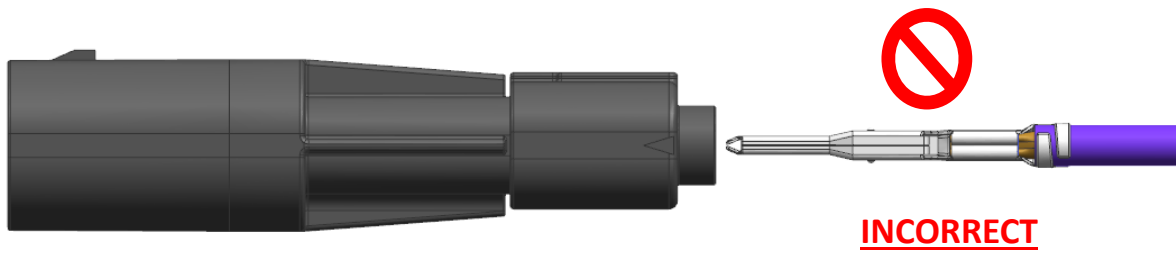

REVISION: <b>B</b>	ECM INFORMATION: EC No: 732935 DATE: 2022/12/22	TITLE: <b>APPLICATION SPECIFICATION SQUBA 3.6 INTERCONNECT SYSTEM</b>	SHEET No. <b>9 of 14</b>
DOCUMENT NUMBER: <b>2077760000-AS</b>	DOC TYPE: <b>PS</b>	DOC PART: <b>000</b>	CREATED / REVISED BY: <b>VENKAS5</b>
		CHECKED BY: <b>VENKAS5</b>	APPROVED BY: <b>MRAMAKRISHNA</b>

**CARE MUST BE TAKEN WHEN HANDLING THE TERMINAL PINS.**

**DO NOT USE OR TRY TO ATTEMPT TO REWORK BENT OR DAMAGED TERMINAL PINS**

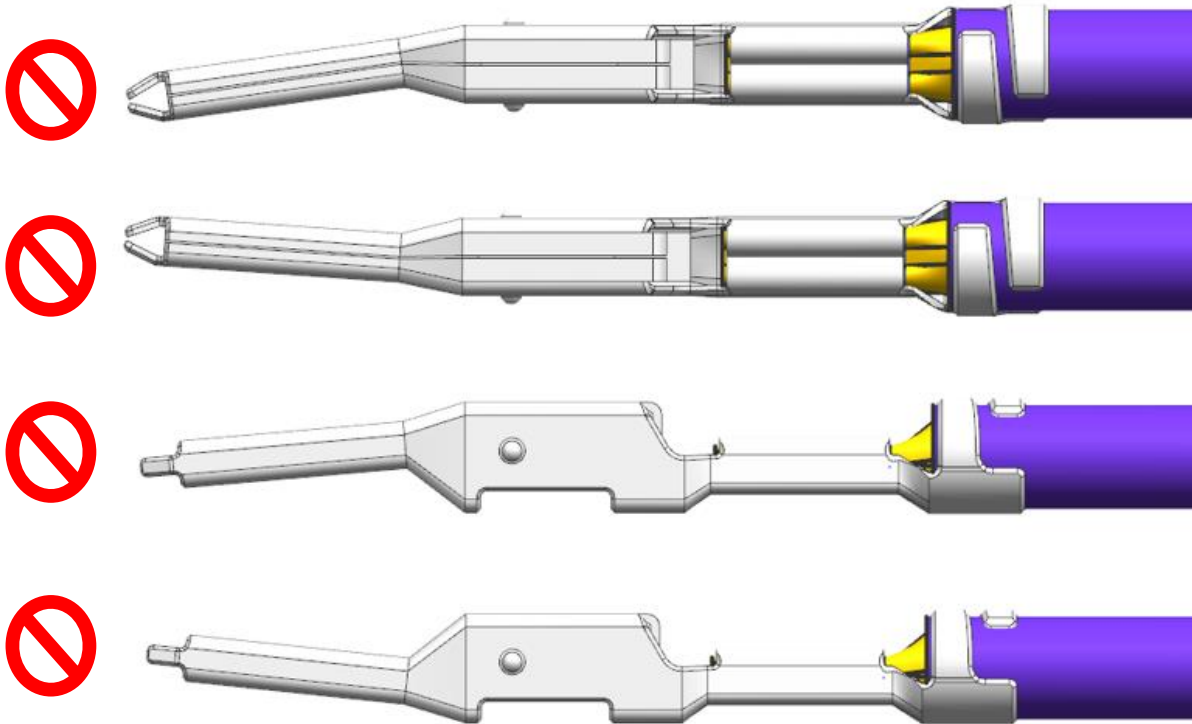

REVISION: <b>B</b>	ECM INFORMATION: EC No: <b>732935</b> DATE: <b>2022/12/22</b>	TITLE: <b>APPLICATION SPECIFICATION SQUBA 3.6 INTERCONNECT SYSTEM</b>	SHEET No. <b>10 of 14</b>
DOCUMENT NUMBER: <b>2077760000-AS</b>	DOC TYPE: <b>PS</b>	DOC PART: <b>000</b>	CREATED / REVISED BY: <b>VENKAS5</b>
		CHECKED BY: <b>VENKAS5</b>	APPROVED BY: <b>MRAMAKRISHNA</b>

## PUSH → CLICK → PULL

(APPLIES TO BOTH RECEPTACLE AND PLUG)

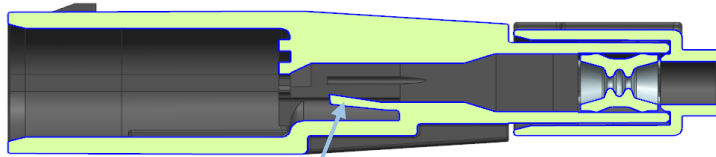

HOUSING LOCK

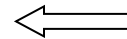
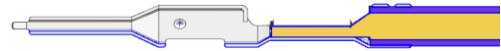

**PUSH** (INSERT TERMINAL)

SLIGHT RESISTANCE WILL BE FELT AS TERMINAL PUSHES THROUGH THE SEAL THEN AGAIN AS THE TERMINAL ENGAGES THE HOUSING LOCK.

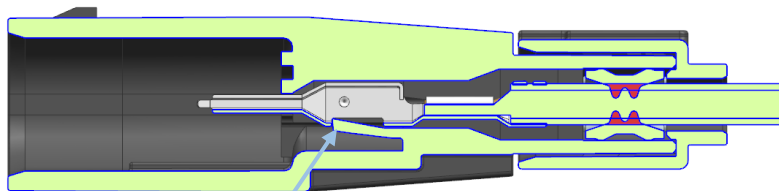

**CLICK** (LISTEN FOR AUDIBLE CLICK)

AUDIBLE CLICK IS HEARD AFTER TERMINAL ENGAGES THE HOUSING LOCK

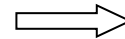
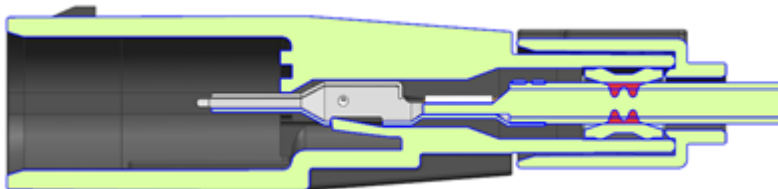

**PULL** (GENTLY PULL ON WIRE)

PULL GENTLY ON WIRE TO ENSURE TERMINAL IS FULLY SEATED AND SECURED BY HOUSING LOCK.

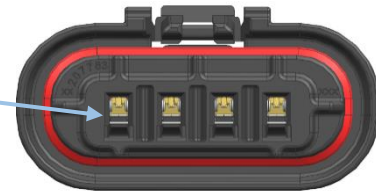
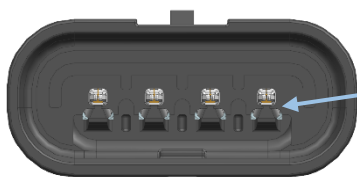

**FULLY SEATED**  
MATING SIDE VIEW

REVISION: <b>B</b>	ECM INFORMATION: EC No: <b>732935</b> DATE: <b>2022/12/22</b>	TITLE: <b>APPLICATION SPECIFICATION SQUBA 3.6 INTERCONNECT SYSTEM</b>	SHEET No. <b>11 of 14</b>
DOCUMENT NUMBER: <b>2077760000-AS</b>	DOC TYPE: <b>PS</b>	DOC PART: <b>000</b>	CREATED / REVISED BY: <b>VENKAS5</b>
		CHECKED BY: <b>VENKAS5</b>	APPROVED BY: <b>MRAMAKRISHNA</b>

## 6.0 MATING AND UN-MATING

### 6.1 CONNECTORS

This product contains a polarization feature to ensure proper orientation during mating. This rib feature is shown below. When mated in the improper orientation this rib feature will not allow the product to be mated.

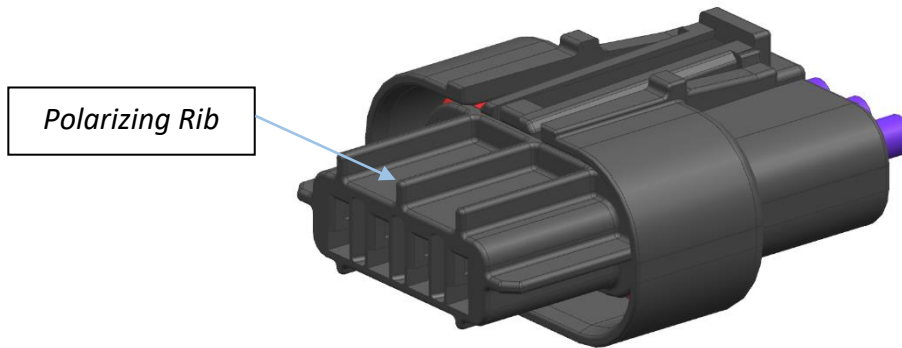

This product also contains a positive locking thumb latch and corresponding latch hook to ensure full mating and prevent accidental un-mating during normal operation. This thumb latch and latch hook features and full mating of the connectors occurs when and after the thumb latch is fully engaged and locked as shown below. A light audible click is heard to indicate fully mated connectors.

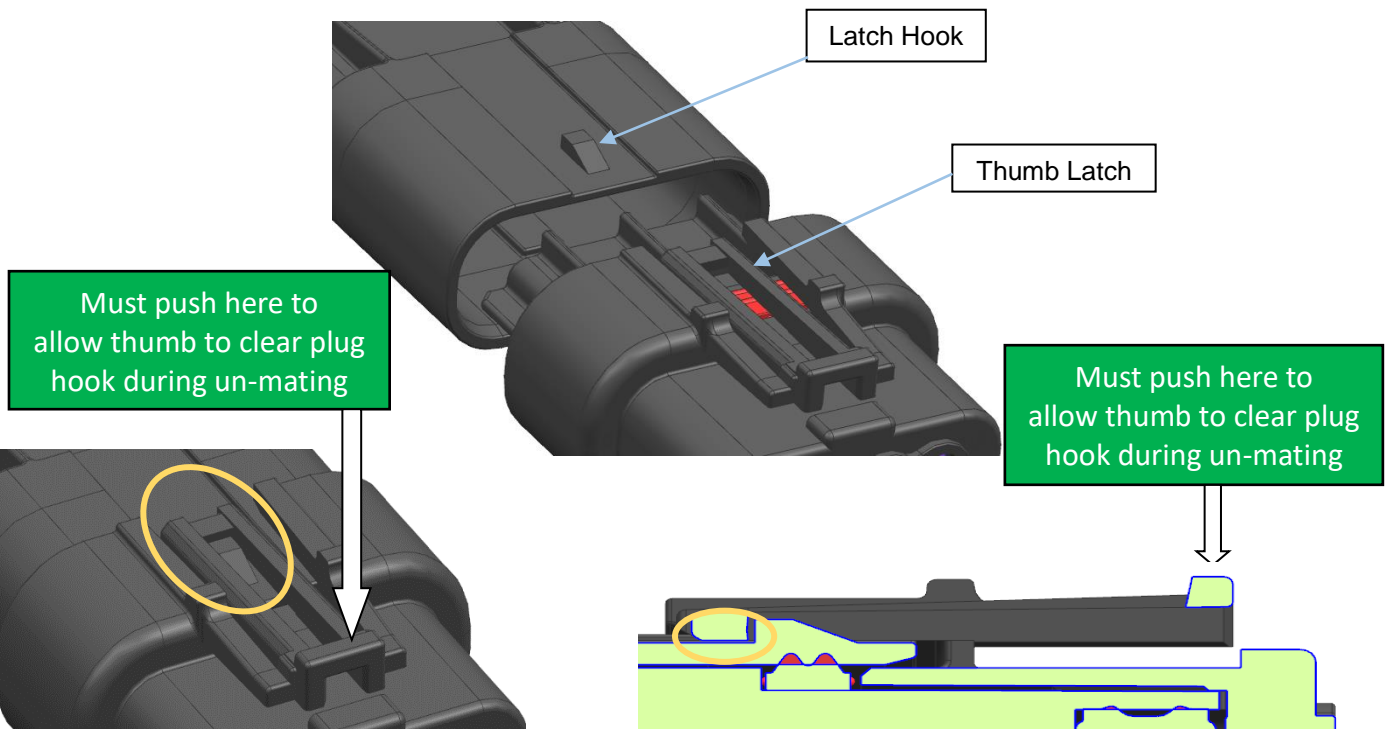

REVISION: <b>B</b>	ECM INFORMATION: EC No: <b>732935</b> DATE: <b>2022/12/22</b>	TITLE: <b>APPLICATION SPECIFICATION SQUBA 3.6 INTERCONNECT SYSTEM</b>	SHEET No. <b>12 of 14</b>
DOCUMENT NUMBER: <b>2077760000-AS</b>	DOC TYPE: <b>PS</b>	DOC PART: <b>000</b>	CREATED / REVISED BY: <b>VENKAS5</b>
		CHECKED BY: <b>VENKAS5</b>	APPROVED BY: <b>MRAMAKRISHNA</b>

## 6.2 WEATHER CAPS

Plug Weather Caps are to be inserted in the Plug housings as shown below. Notice the orientation of the Cap with the plug Housing.

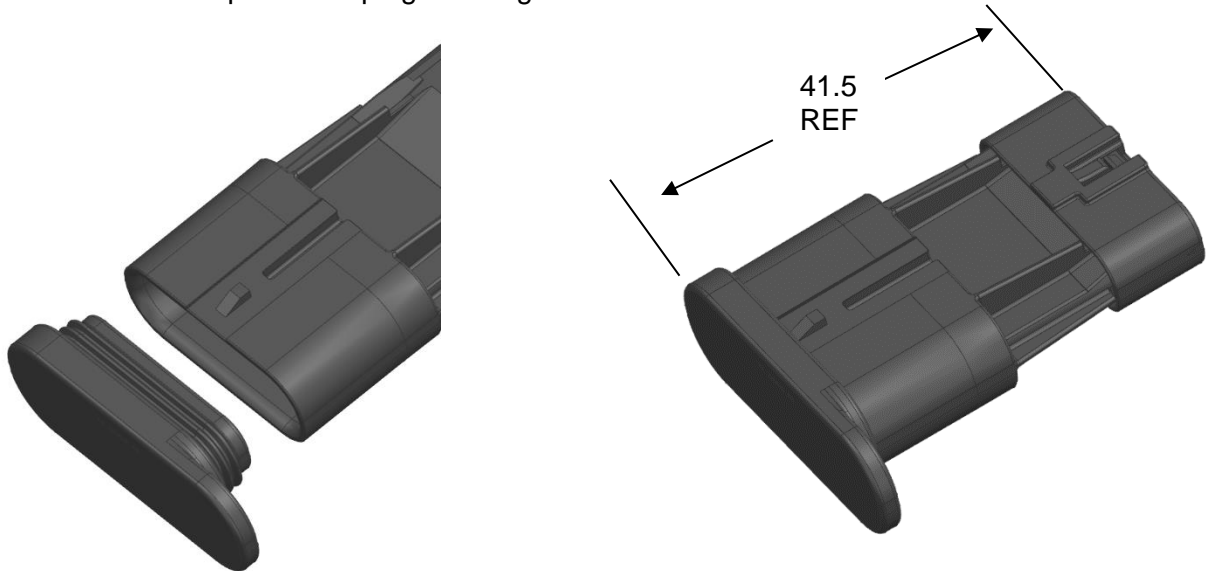

Receptacle weather cap can be mated to receptacle which a positive locking thumb latch and corresponding latch hook to ensure full mating and prevent accidental un-mating during normal operation. This thumb latch and latch hook features and full mating of the assembly occurs when and after the thumb latch is fully engaged and locked as shown below. A light audible click is heard to indicate fully mated.

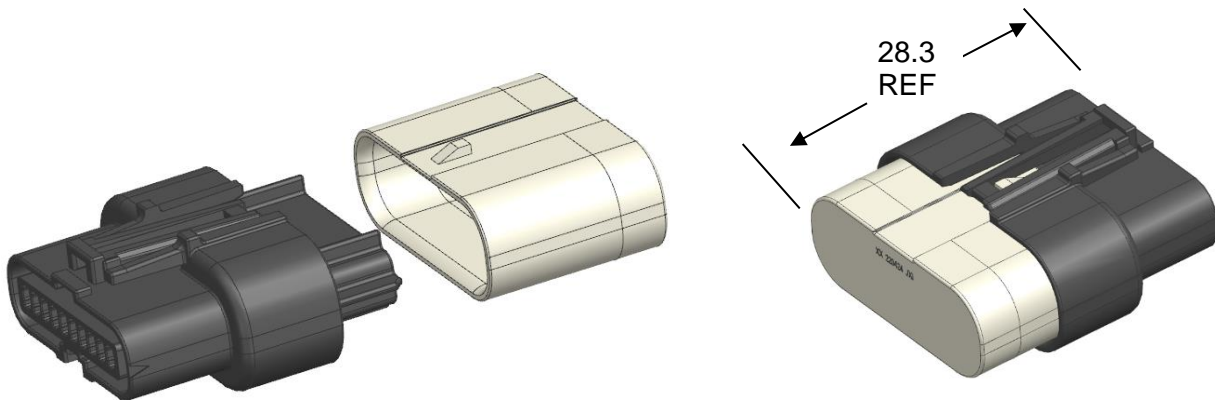

REVISION: <b>B</b>	ECM INFORMATION: EC No: <b>732935</b> DATE: <b>2022/12/22</b>	TITLE: <b>APPLICATION SPECIFICATION SQUBA 3.6 INTERCONNECT SYSTEM</b>	SHEET No. <b>13 of 14</b>
DOCUMENT NUMBER: <b>2077760000-AS</b>	DOC TYPE: <b>PS</b>	DOC PART: <b>000</b>	CREATED / REVISED BY: <b>VENKAS5</b>
		CHECKED BY: <b>VENKAS5</b>	APPROVED BY: <b>MRAMAKRISHNA</b>

## 7.0 PACKAGING

Parts shall be packaged to protect against damage during handling, transit and storage. See packaging specifications listed in section 3.0 (sheet 2).

## 8.0 OTHER INFORMATION

### 8.1 CABLE TIE AND OR WIRE TWIST LOCATION

CKT Size	Dim T Min.
2	50.8 mm (2.00")
3	50.8 mm (2.00")
4	76.2 mm (3.00")

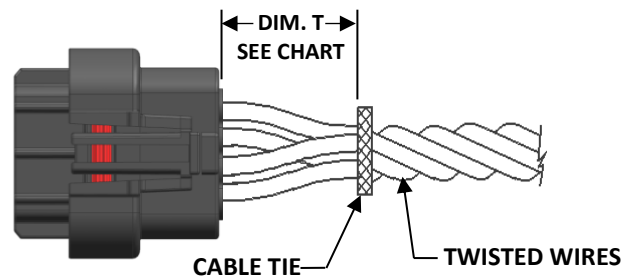

The “T” dimension defines a “free” length of wire, or a length of wire that is not subject to significant bias by external factors such as a wire tie, wire twisting, or other means of bending or deforming of the wires that repositions them from their natural relaxed state or location where they enter the housing. Wires are to be dressed in such a manner to allow the terminals to float freely in the pocket. This dimension is a general recommendation and may need to be adjusted for different wire gauges and wire type and insulation thickness and insulation material.

REVISION: <b>B</b>	ECM INFORMATION: EC No: <b>732935</b> DATE: <b>2022/12/22</b>	TITLE: <b>APPLICATION SPECIFICATION SQUBA 3.6 INTERCONNECT SYSTEM</b>				SHEET No. <b>14 of 14</b>
DOCUMENT NUMBER: <b>2077760000-AS</b>	DOC TYPE: <b>PS</b>	DOC PART: <b>000</b>	CREATED / REVISED BY: <b>VENKAS5</b>	CHECKED BY: <b>VENKAS5</b>	APPROVED BY: <b>MRAMAKRISHNA</b>	