

THIS DRAWING IS UNPUBLISHED. RELEASED FOR PUBLICATION, 19
 © COPYRIGHT 19 BY AMP INCORPORATED. ALL INTERNATIONAL RIGHTS RESERVED.

LOC	DIST	P	F	REVISIONS			
ZONE	LTR	DESCRIPTION	DATE	APPD			
AF	50			B	REL PER 063A-0580-01	150CT01	JR/PD

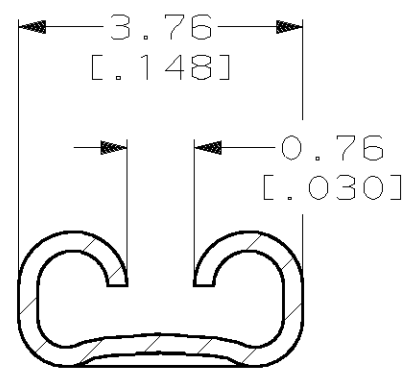
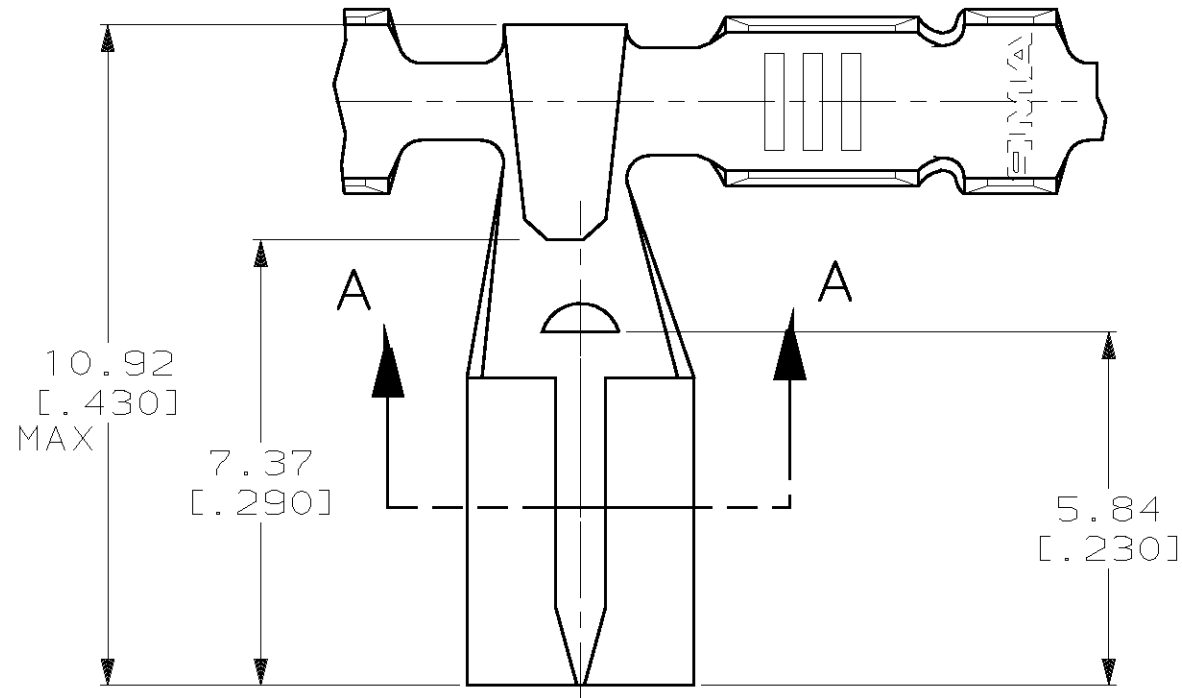

SECTION A-A
SCALE 10:1

- CONTINUOUS STRIP ON REELS
- WIRE SIZE IS [#22-#18] AWG.
- INSULATION RANGE IS 1.52-2.54 [.060-.100] DIA.
- MATING TAB THK TO BE 0.81±0.025 [.032±.001].

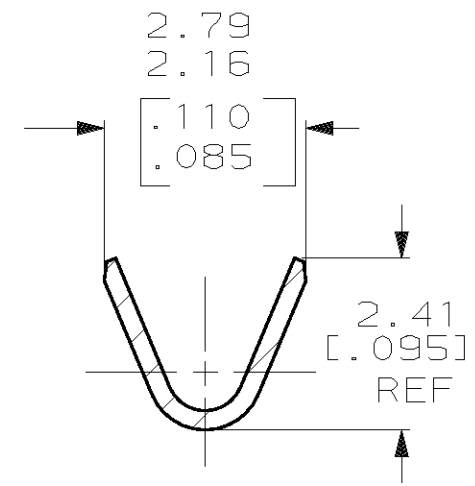

SECTION B-B
SCALE 10:1

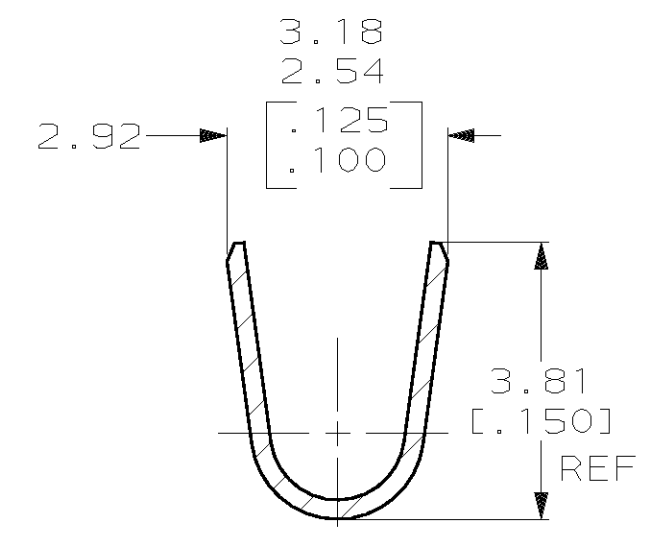

SECTION C-C
SCALE 10:1

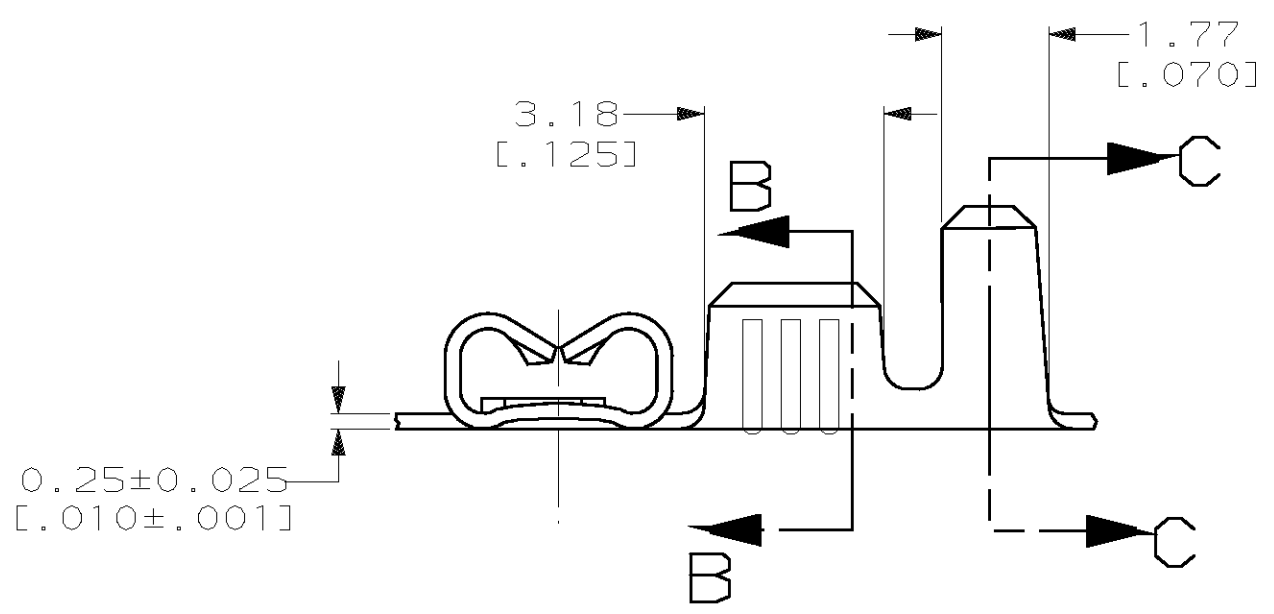

1217171-1

PART NO

DO NOT SCALE PRINT. UNLESS SPECIFIED DIMENSIONS ARE IN MM [INCHES] TOLERANCES ON: 2 PLC DEC ± - 3 PLC DEC ± 0.25 [.010] ANGLES ± -	DR 07JUN99 JR RUTH	AMP Incorporated Harrisburg, PA 17105-3608
	CHK 07JUN99 MS FEHER	
	APPD 07JUN99 S HEADER	
	APPD 07JUN99 D ROTELL	
MATERIAL H04 BRASS	PRODUCT SPEC -	NAME RECEPTACLE, FASTON, FLAG, 2.79 [.110] SERIES
FINISH TIN PLATE	APPLICATION SPEC -	SIZE B
	WEIGHT -	CAGE CODE 00779
		DRAWING NO 1217171
		SCALE 8:1
		SHEET 1 OF 1

CUSTOMER DRAWING