



American Opto Plus LED Corp.

SMA-B500LB B/W

11.5 x 2.4 x 3.1mm Blue Display Light Bar

MECHANICAL DIMENSIONS

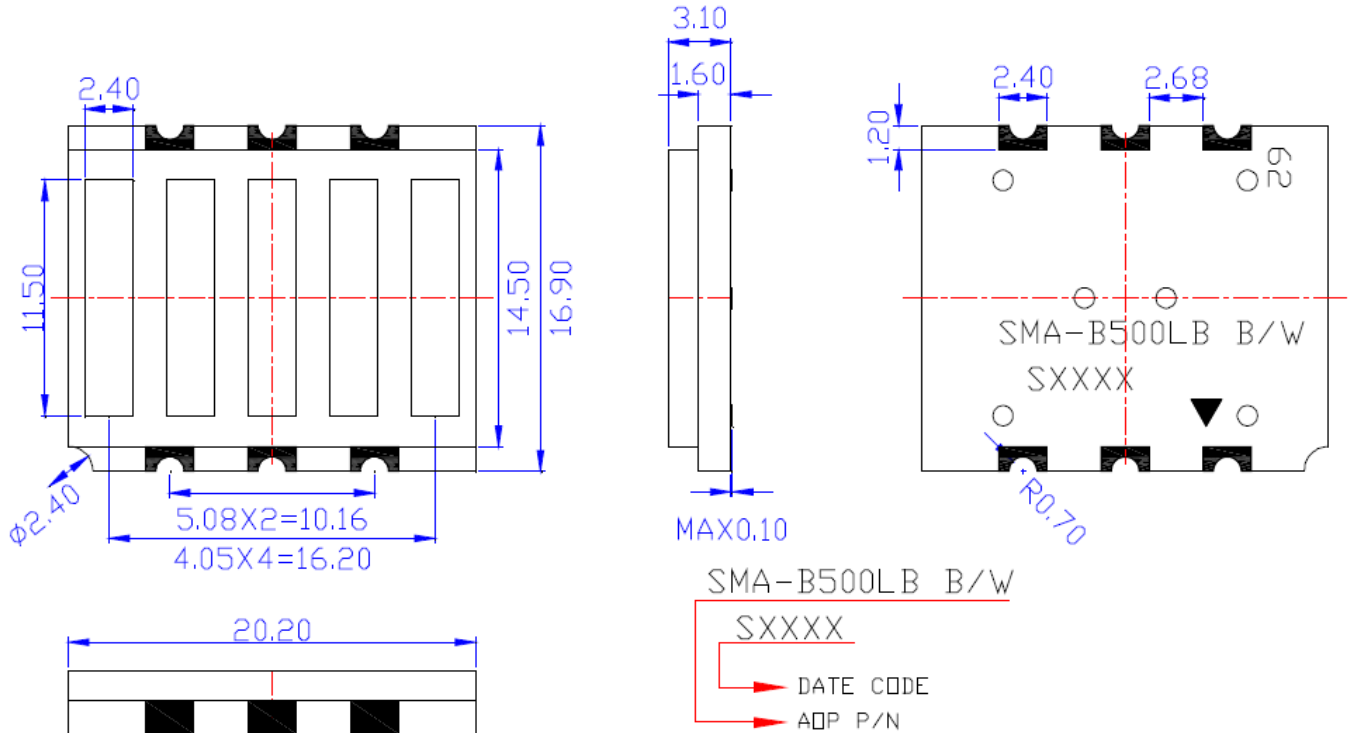

Notes:

1. Dimension in millimeter [inch], tolerance is ± 0.25 [0.10] unless otherwise noted.
2. Bending ≤ 0.25 mm

Chip Material	Emitted Color	Segment/Face	Description
InGaN	Blue	White/Black	Common Anode



American Opto Plus LED Corp.

SMA-B500LB B/W

11.5 x 2.4 x 3.1mm Blue Display Light Bar

ALL LIGHT ON SEGMENTS FEATURE & PAD POSITION

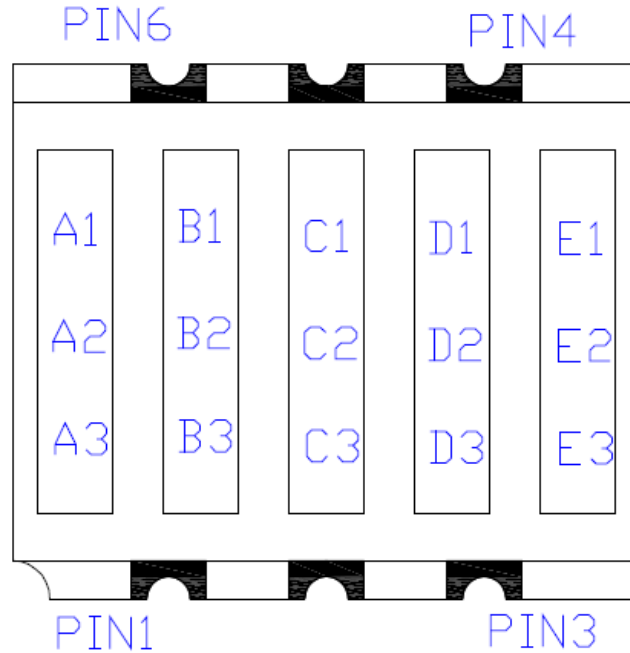

INTERNAL CIRCUIT DIAGRAMS

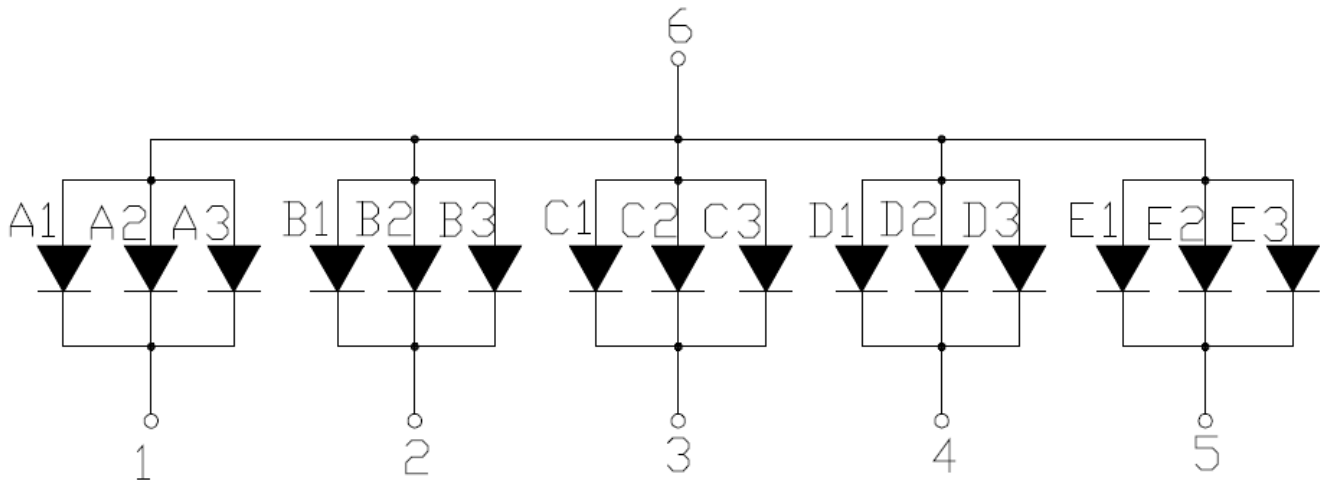



American Opto Plus LED Corp.

SMA-B500LB B/W

11.5 x 2.4 x 3.1mm Blue Display Light Bar

ABSOLUTE MAXIMUM RATING

(Ta=25°C)

Parameter	Symbol	Rating	Unit
Power Dissipation (Per Dice)	P_D	120	mW
Continuous Forward Current (Per Dice)	I_F	30	mA
Peak Current (Per Dice, duty cycle 1/10,1KHz)	I_{FP}	100	mA
Derating Liner from 25°C(Per Dice)	$\Delta I_F/\Delta T$	0.3	mA/°C
Reverse Voltage (Per Dice)	V_R	5	V
Electrostatic Discharge (HBM)	ESD	1000	V
Operating Temp.	T_{OPR}	-40 ~ +105	°C
Storage Temp.	T_{STG}	-40 ~ +105	°C
Hand Soldering Temp.	T_{SOL}	350	°C

ELECTRO-OPTICAL CHARACTERISTICS

(Ta=25°C)

Parameter	Symbol	Condition	Min.	Typ.	Max.	Unit
Forward Voltage (Per Dice)	V_F	IF=20mA	--	3.2	4	V
Dominant Wavelength	Λ_d		--	470	--	nm
Spectrum Radiation Bandwidth	$\Delta\lambda$		--	30	--	nm
Luminous Intensity (Per Icon)	I_V		--	50	--	mcd
Luminous Intensity Matching Ratio	I_V-m		--	--	2:1	--
Reverse Current	I_r	VR=8V	--	--	10	μA



American Opto Plus LED Corp.

SMA-B500LB B/W

11.5 x 2.4 x 3.1mm Blue Display Light Bar

ELECTRICAL/OPTICAL CHARACTERISTICS CURVES

($T_a = 25^\circ\text{C}$ Unless Otherwise Noted)

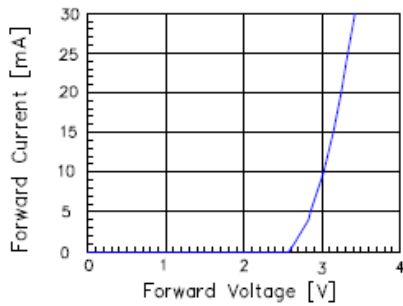

Fig 1. Forward Current vs. Forward Voltage

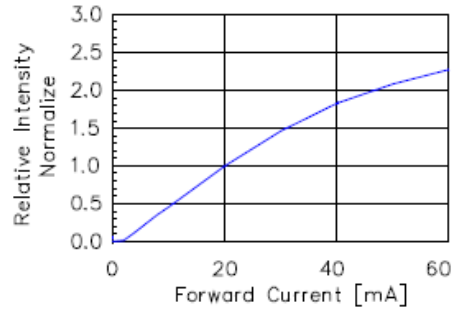

Fig 2. Relative Intensity vs. Forward Current

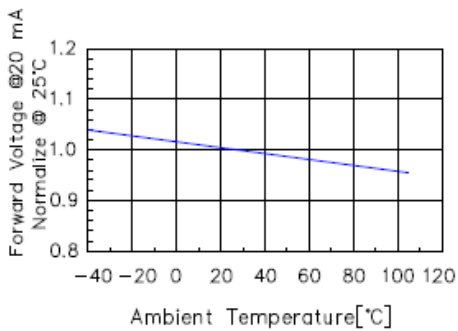

Fig 3. Forward Voltage vs. Temperature

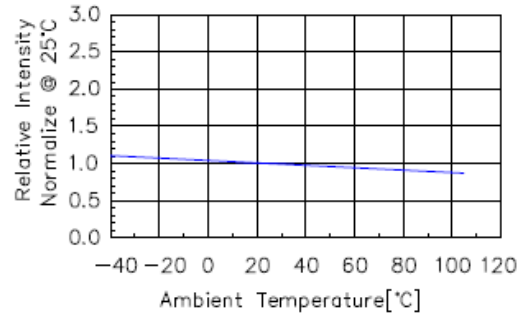

Fig 4. Relative Intensity vs. Temperature

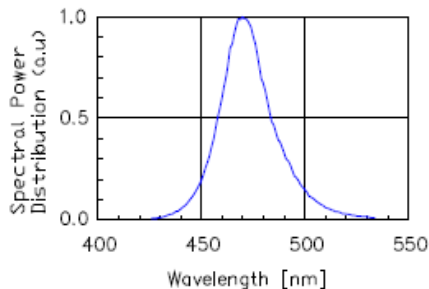

Fig 5. Spectral Power Distribution vs. Wavelength

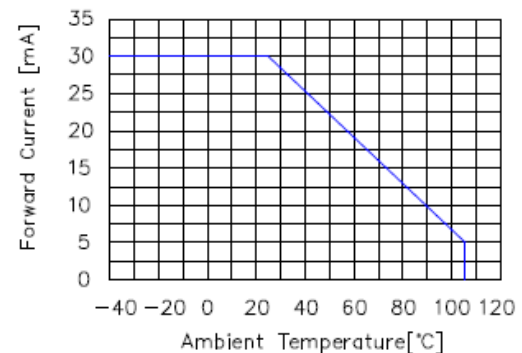

Fig 6. Forward current vs. Temperature



American Opto Plus LED Corp.

SMA-B500LB B/W

11.5 x 2.4 x 3.1mm Blue Display Light Bar

SOLDERING CHARACTERISTICS

1. IR-Reflow Soldering Profile

Item	Title	Symbol	Min	Max	Unit
Preheat	Ramp-Up Rate	Vp	1	5	°C/Sec
	Temperature	Tp	150	--	°C
	Time	tp	--	--	Sec
Solder Dip	Ramp-Up Rate	Ve	--	--	°C/Sec
	Temperature	Te	150	200	°C
	Time	te	60	120	Sec
Reflow	Ramp-Up Rate	Vr	1	5	°C/Sec
	Temperature	Tr	220	--	°C
	Time	tr	--	60	Sec
	Peak Temperature	Trp	--	260	°C
	Peak Time	trp	--	10	Sec
Cooling	Ramp-Down Rate	Vc	3	6	°C/Sec

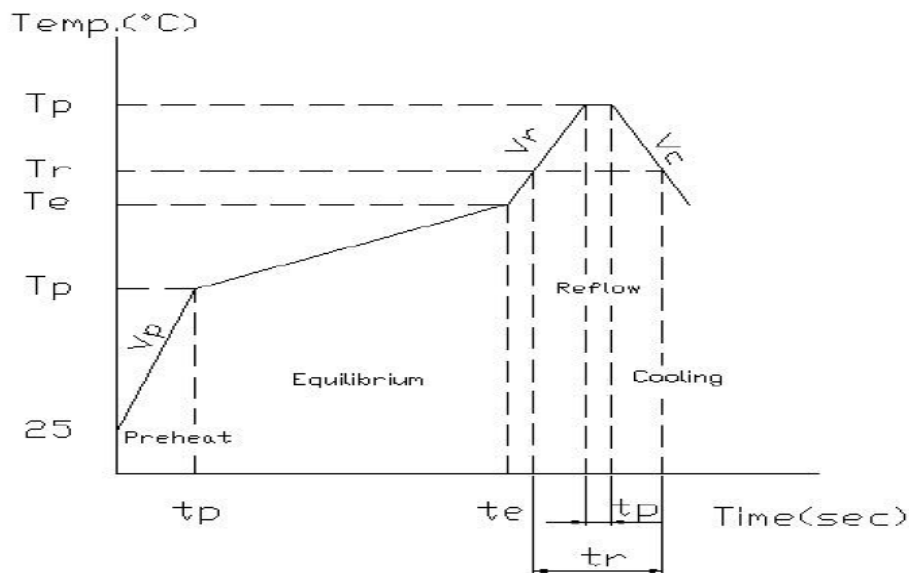



American Opto Plus LED Corp.

SMA-B500LB B/W

11.5 x 2.4 x 3.1mm Blue Display Light Bar

2. Hand Soldering Condition

1. Soldering Iron: 30W Max.
2. Temperature: 350°C Max.
3. Soldering Time: 3 seconds Max. (1 time)
4. Distance: 1.6mm min.(from seating plane)

SOLDERING PAD SIZE

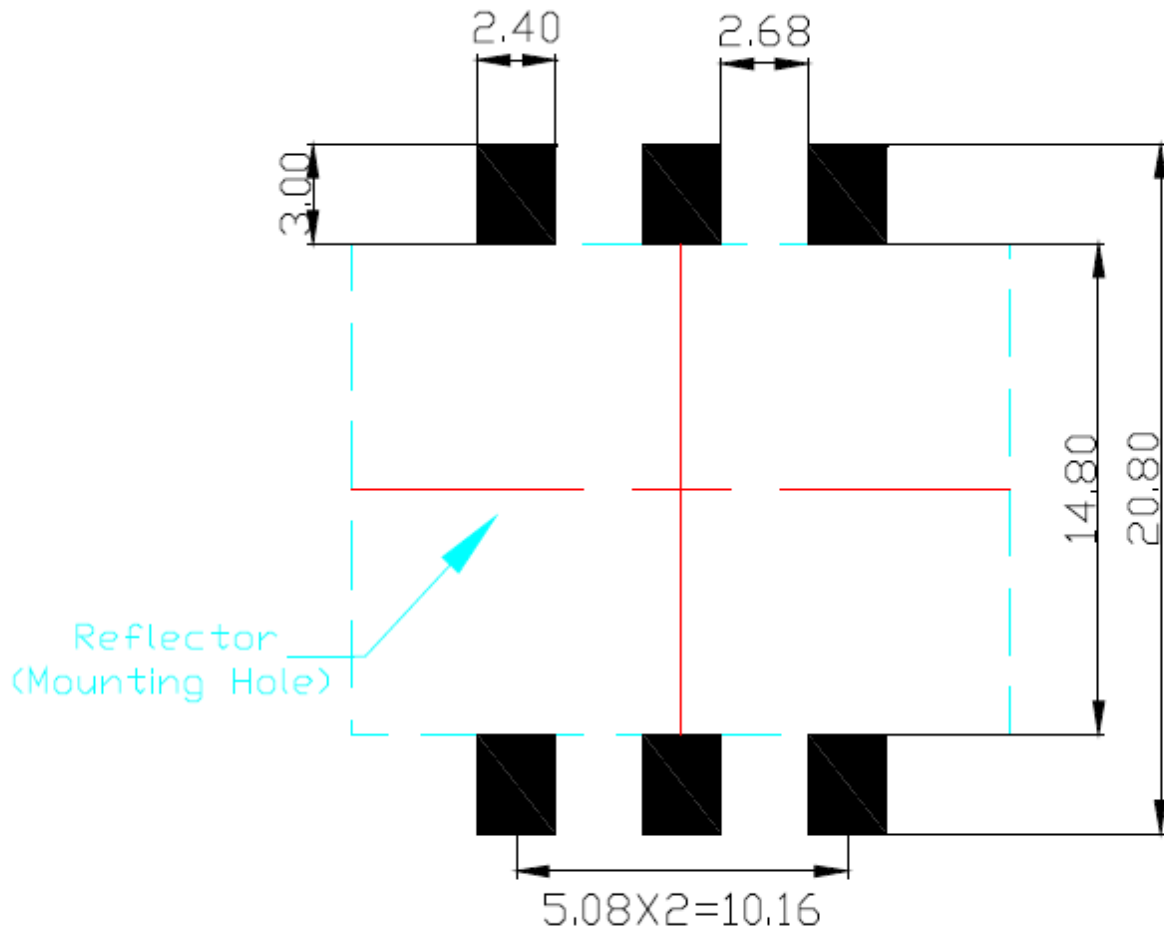



American Opto Plus LED Corp.

SMA-B500LB B/W

11.5 x 2.4 x 3.1mm Blue Display Light Bar

REEL DIMENSIONS

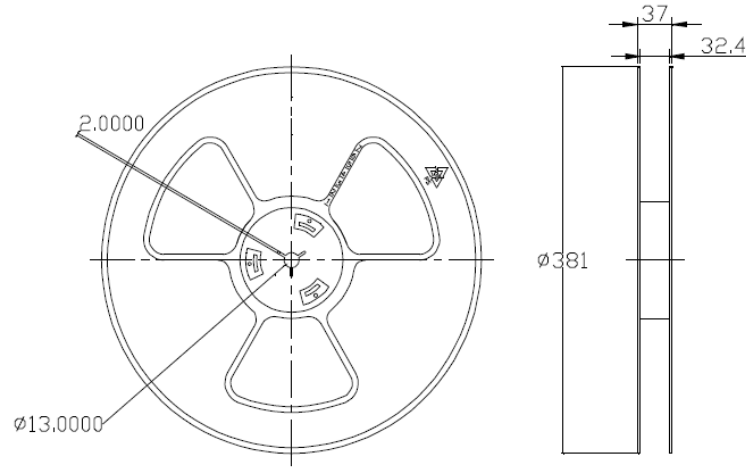

PACKING & LABEL DIMENSIONS

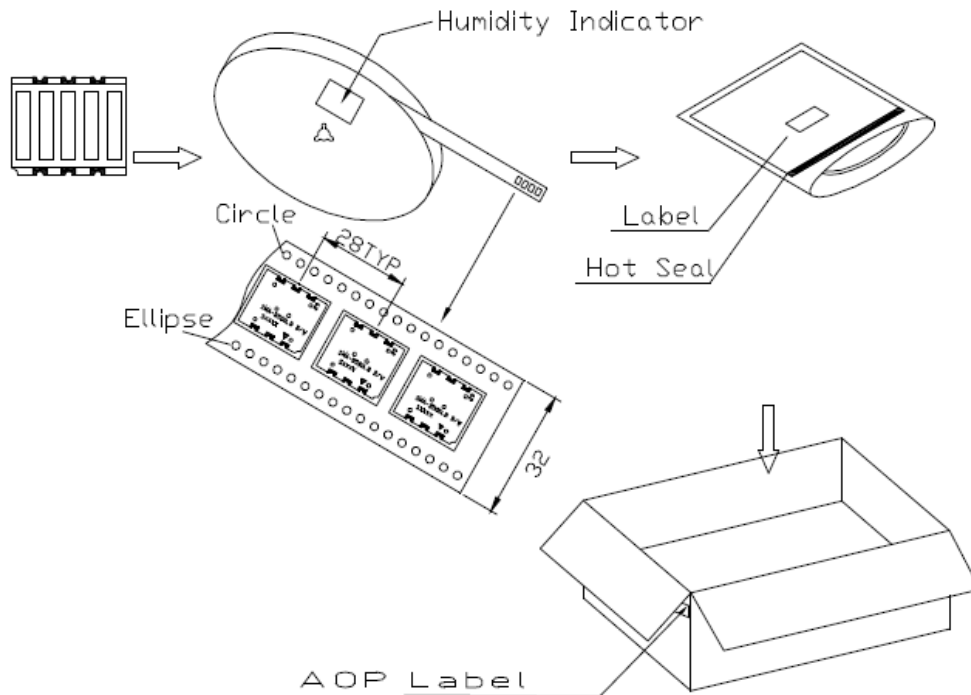

Package Name	Size	Unit	Amount	Unit	Amount	Unit	Note
Reel	Φ381	mm	1	Reel	600	Pcs	/
Bag	L450*W430	mm	1	Reel	600	Pcs	/
Outer Box	L430*W390*H300	mm	7	Inner Box	4200	Pcs	/



American Opto Plus LED Corp.
SMA-B500LB B/W
11.5 x 2.4 x 3.1mm Blue Display Light Bar

STORAGE METHOD

1. Storage Conditions:

Before opening the package:

The LEDs should be kept at 30°C or less and 90%RH or less. The LEDs should be used within a year. When storing the LEDs, moisture proof packaging with absorbent material (silica gel) is recommended.

After opening the package:

The LEDs should be kept at 30°C or less and 70%RH or less. The LEDs should be soldered within 168 hours (7days) after opening the package. If unused LEDs remain, they should be stored in moisture proof packages, such as sealed containers with packages of moisture absorbent material (silica gel). It is also recommended to return the LEDs to the original moisture bag and to reseal the moisture proof bag again.

2. If the moisture absorbent material (silica gel) has faded away or the LEDs have exceeded the storage time, baking treatment should be performed using the following conditions:

Baking treatment: more than 24hours at 65±5°C