

General Description

The AOZ7270 is a 600V AlphaZBL™ product that uses an internal 190mΩ N-channel MOSFET to replace a diode when used in AC/DC diode-bridge application. The AOZ7270 reduces power consumption and improves thermals.

The Schottky diode bridge rectifier is a classic circuit used for full-wave ac-to-dc rectification and dc polarity correction. The high VF of high voltage Schottky diodes cause high power loss and pose a thermal challenge. AOS' AlphaZBL product uses a controller + 600V MOSFET to enable ideal diode operation and can be used to replace the schottky diode. Replacing the 4 diodes in a full-wave bridge rectifier circuit with a low loss MOSFET reduces power dissipation and results in improved thermals and higher reliability operation.

The AOZ7270 is self-powered from the AC line without the need of an extra voltage supply.

The AOZ7270 is available in a 5mm×7mm DFN-12L package and is rated over a -40°C to +125°C ambient temperature range.

Features

- Replaces a power diode in HV bridge rectifier
- Self-powered in AC system
- Internal 0.19Ω 600V N-channel MOSFET
- Low reverse threshold 1mV
- Low quiescent current 5uA
- Thermally enhanced

Applications

- AC/DC
- HV bridge rectifier



Typical Application

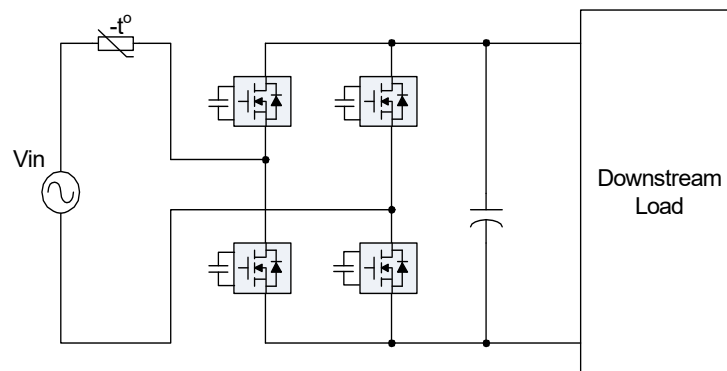

Ordering Information

Part Number	Ambient Temperature Range	Package	Environmental
AOZ7270DI	-40°C to +125°C	DFN5x7-12L	RoHS



AOS Green Products use reduced levels of Halogens, and are also RoHS compliant. Please visit www.aosmd.com/media/AOSGreenPolicy.pdf for additional information.

Pin Configuration

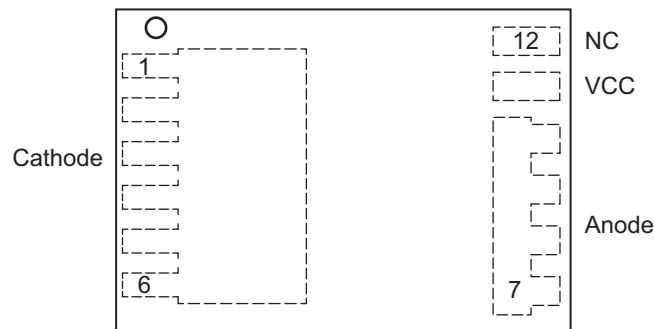

5mm x 7mm DFN-12L
(Top Transparent View)

Pin Description

Pin Number	Pin Name	Pin Function
1-6	Cathode	Cathode of diode
7-10	Anode	It is like anode of diode, and it is reference ground of controller
11	VCC	Power source for controller
12	NC	No connection

Absolute Maximum Ratings

Exceeding the Absolute Maximum ratings may damage the device.

Parameter	Rating
V _{CC} to Anode	-0.3V to 24V
Cathode to Anode	-1V to 600V
Junction Temperature (T _J)	150°C
Storage Temperature (T _S)	-65°C to 150°C
ESD Rating ⁽¹⁾	2kV

Note:

1. Devices are inherently ESD sensitive, handling precautions are required. Human body model rating: 1.5kΩ in series with 100pF.

Recommend Operating Ratings

The device is not guaranteed to operate beyond the Maximum Operating Ratings.

Parameter	Rating
Supply Voltage (V _{CC})	16V
Ambient Temperature (T _A)	-40°C to 125°C
Package Thermal Resistance 5x7 DFN-12 (θ _{JA})	60°C/W
Package Thermal Resistance 5x7 DFN-12 (θ _{JC})	2.6°C/W

Electrical Characteristics

T_A = 25°C, V_{CC} = 16V, V_{anode} = 0V, unless otherwise specified. Specifications in **Bold** indicate an ambient temperature range of -40°C to +125°C. These specifications are guaranteed by design.

Symbol	Parameter	Conditions	Min.	Typ.	Max.	Units
V _{RRM}	Repetitive peak reverse voltage		600			V
R _{DS(ON)}	Static cathode-anode on-resistance				0.19	Ω
I _S	Max. body-diode continuous current ⁽²⁾				20	A
I _{SM}	Max. body-diode pulsed current ⁽²⁾⁽³⁾				80	A
V _{CC_UP}	V _{CC} UVLO rising	V _{ca} = -0.2V, V _{CC} rising monitor I _{ca} > 0.1A	13.5	15.2	17	V
V _{CC_UVLO}	V _{CC} UVLO falling	V _{ca} = -0.2V, V _{CC} falling monitor I _{ca} = 0A	11	12.9	14	V
I _{Charge}	Charging for V _{CC}	V _{ca} = 30V, V _{CC} = 12V, measure I _{cathode}	1			mA
I _{OP}	V _{CC} operation current at on-state	V _{CC} = 16V, V _{ca} = -0.1V, measure I _{VCC}		12		μA
I _Q	V _{CC} quiescent current at off-state	V _{CC} = 16V, V _{ca} = 0.1V, measure I _{VCC}		5		μA
V _{CA_ON}	Switch turn-on threshold	V _{CC} = 16V, V _{ca} falling, monitor I _{ca} > 0.1A		-105		mV
V _{CA_OFF}	Switch turn-off threshold	V _{CC} = 16V, V _{ca} falling, monitor I _{ca} = 0A		1		mV
I _D	Continuous Drain Current ⁽²⁾	T _c = 25°C			20	A
		T _c = 100°C			12	A
V _{SD}	Diode Forward Voltage	I _S = 10A, V _{GS} = 0V		0.85	1.2	V

Notes:

2. Guaranteed by design.
3. Repetitive rating, pulse width limited by junction temperature T_{J(MAX)} = 150°C, Ratings are based on low frequency and duty cycles to keep initial T_J = 25°C.

Functional Block Diagram

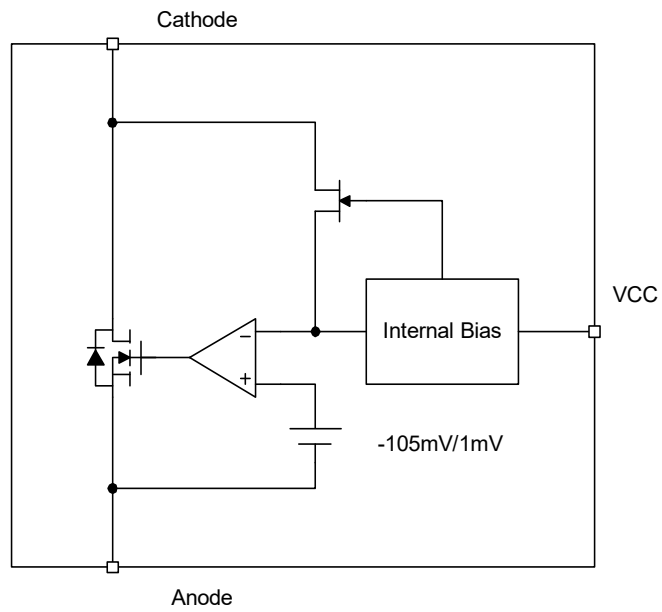

Typical Performance Characteristics

$T_A = 25^\circ\text{C}$, $V_{\text{anode}} = 0\text{ V}$, $V_{\text{CC}} = 16\text{ V}$, unless otherwise specified.

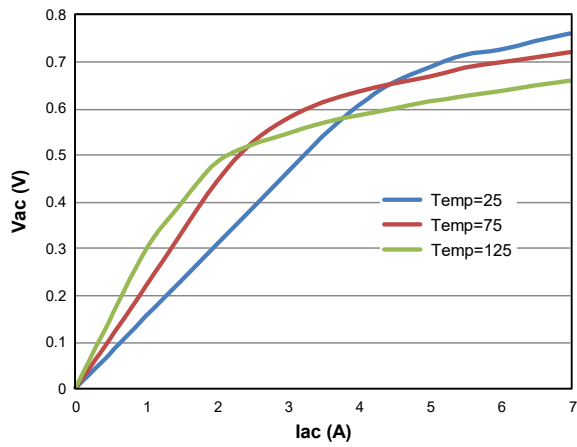

Figure 1. I_{ac} vs. V_{ac}

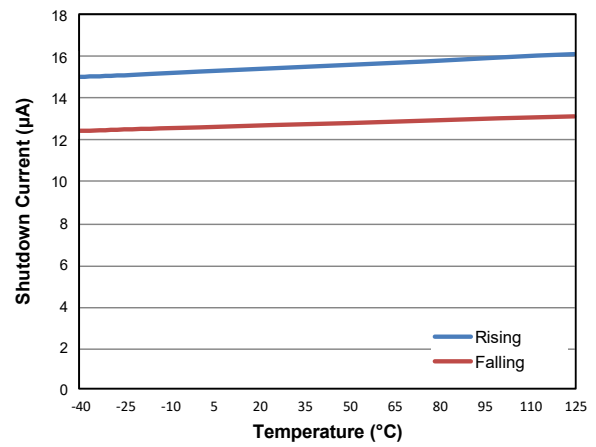

Figure 2. UVLO vs. Temperature

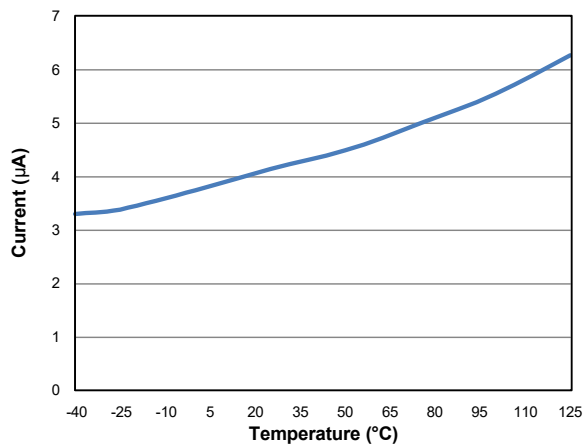

Figure 3. Quiescent Current vs. Temperature

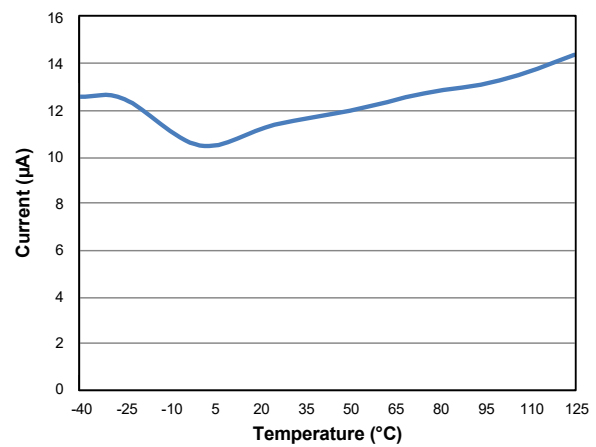

Figure 4. Operation Current vs. Temperature

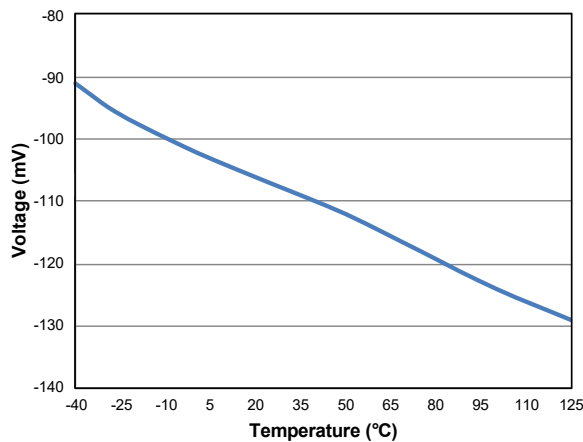

Figure 5. V_{CA_ON} vs. Temperature

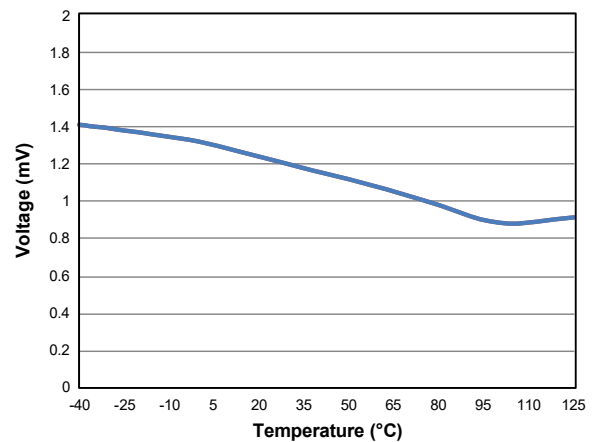

Figure 6. V_{CA_OFF} vs. Temperature

Efficiency

60W Non-PFC Rectifier Efficiency Comparison, Output capacitor is 120uF and Loading is 60W.

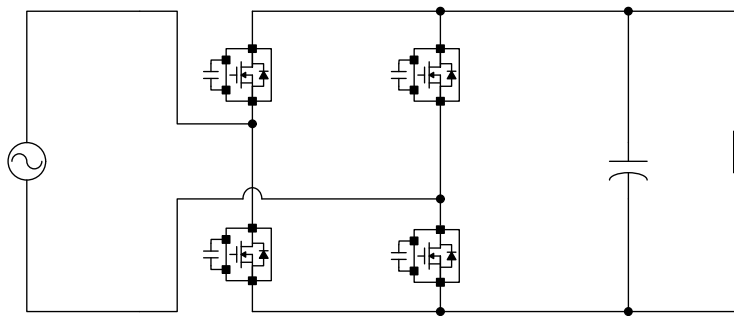

Figure 7. Application Circuit Used for Testing

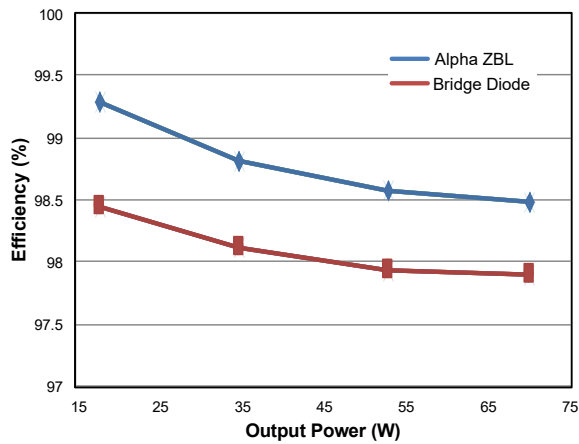

Figure 8. Efficiency Comparison at 115V

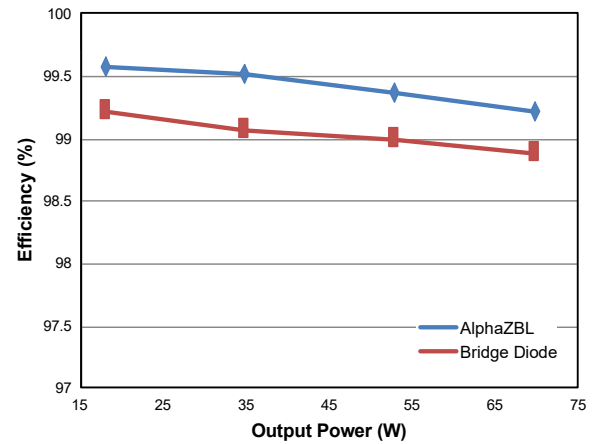

Figure 9. Efficiency Comparison at 230Vac

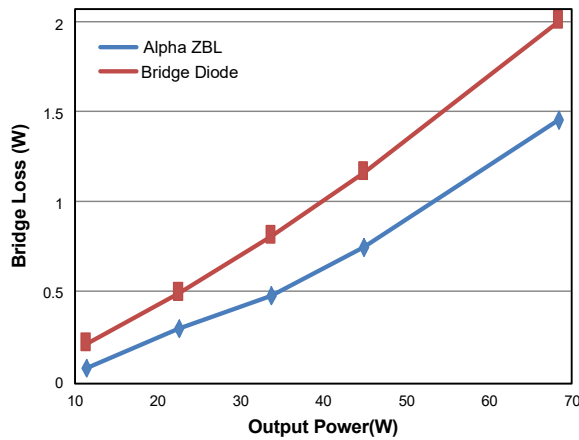

Figure 10. Power loss saved on 60W Rectifier Load Efficiency Comparison

Efficiency (Continued)

100W PFC Converter Efficiency Comparison.

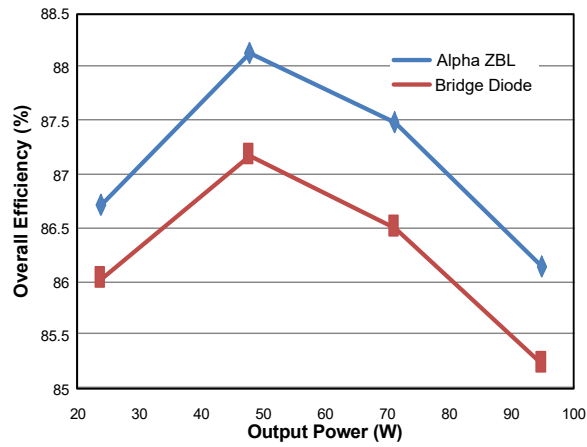

Figure 11. 100W PFC Efficiency at 115V

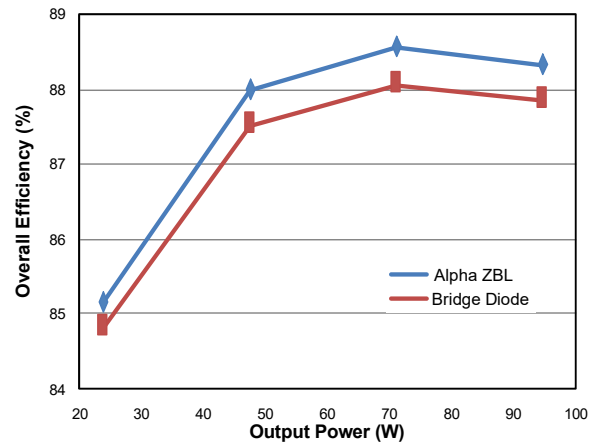

Figure 12. 100W PFC Efficiency at 230Vac

Efficiency (Continued)

60W Converter Efficiency Comparison at 30W and 60W, using 2 diodes and 2 AlphaZBL.

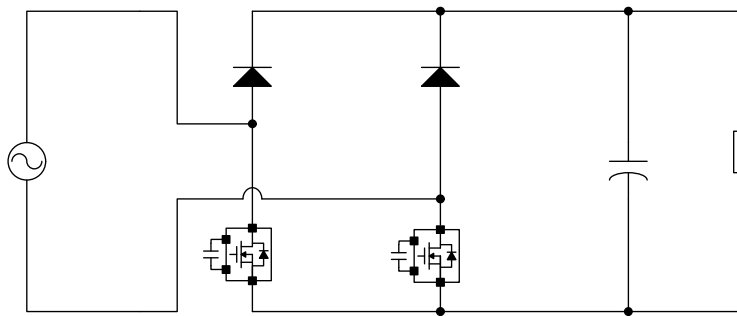

Figure 13. Application Circuit Used for Testing

Table 1. 30W Efficiency Improvement

	90V/60Hz	100V/60Hz	115V/50Hz	230V/50Hz	264V/50Hz
30W with Bridge	91.10%	91.39%	91.74%	91.70%	91.27%
30W with AZBL	91.60%	91.83%	92.12%	92.11%	91.66%
Improved by AZBL	0.50%	0.44%	0.38%	0.41%	0.39%

Table 2. 60W Efficiency Improvement

	90V/60Hz	100V/60Hz	115V/50Hz	230V/50Hz	264V/50Hz
60W with Bridge	90.28%	90.90%	91.33%	92.13%	91.81%
60W with AZBL	90.46%	91.08%	91.52%	92.39%	92.04%
Improved by AZBL	0.18%	0.18%	0.19%	0.26%	0.23%

Surge Test

Test conditions:

- 230V/50Hz Input with 60W EMI filter without NTCR
- Common mode lighting surge(L-FG; N-FG):Pass 4kV⁽²⁾
- Differential mode lighting surge (L-N):Pass 2.5kV*

Note:

4. X-Cap of EMI board broken at the 3kV DM lighting surge, so we don't keep to test at 3kV level. Even X-Cap Broken by the 3kV DM surge, AlphaZBL still in work without fail.

Inrush Current Test

Without NTCR, EMI filter, TVS and varistor. Output capacitor is 120μF. Peak current > 1.2kA_{peak} and pulse with TP=100μs.

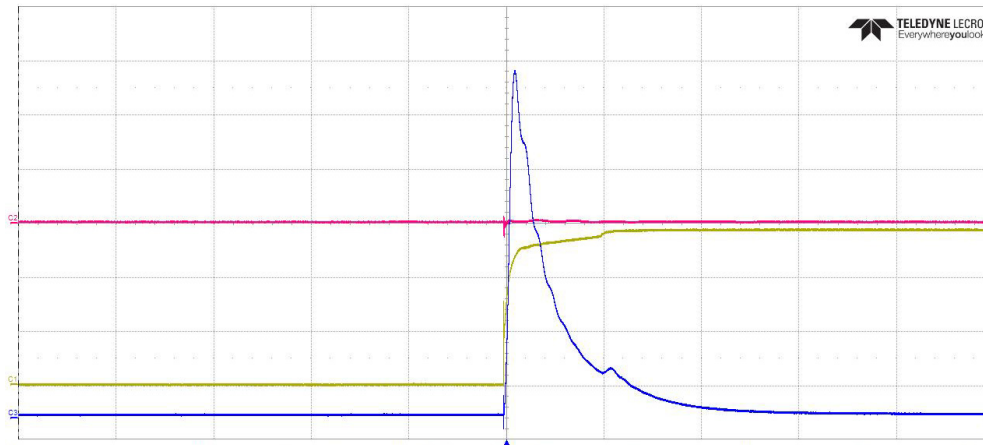

Figure 14. First Time Power On

Repeat inrush current test by the repeat duration with 1 sec and repeat 10k times.

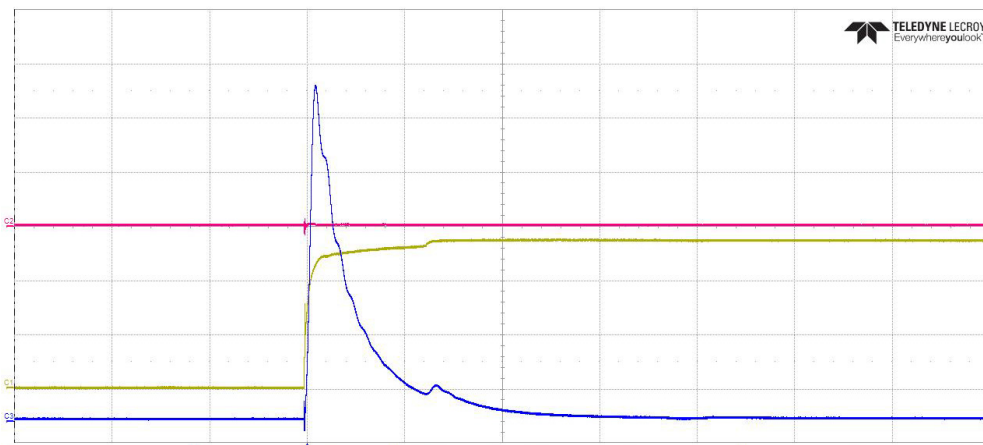

Figure 15. 10k Times Power On

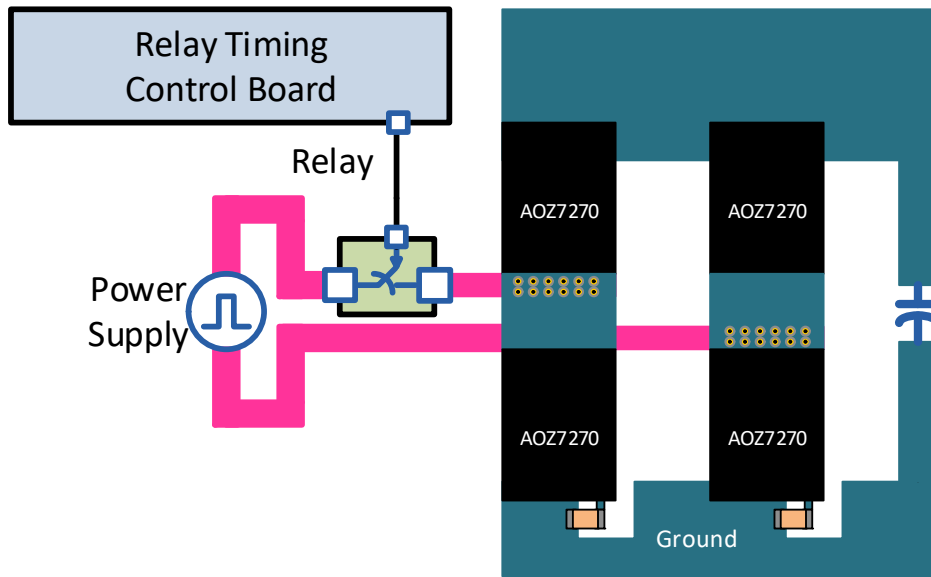

Figure 16. Inrush Test Fixture

Detailed Description

The AOZ7270 with a low-voltage capacitor can replace each diode in high-voltage bridge rectifier application. In normal operation, after V_{CC} UVLO AOZ7270 will sense the voltage between Cathode and Anode, if this voltage is less than -105mV , controller will turn on internal switch and the conduction loss is reduced. In the switch on-cycle, controller keeps to monitor this voltage, when this voltage is larger than 1mV , the controller will turn-off switch.

There is a high voltage depletion MOSFET that could help to charge the V_{CC} capacitor. In normal operation, the charging procedure happens at lower voltage drop and it helps to reduce the quiescent power. The value of V_{CC} capacitor is recommended larger than $1\mu\text{F}/25\text{V}$ for application.

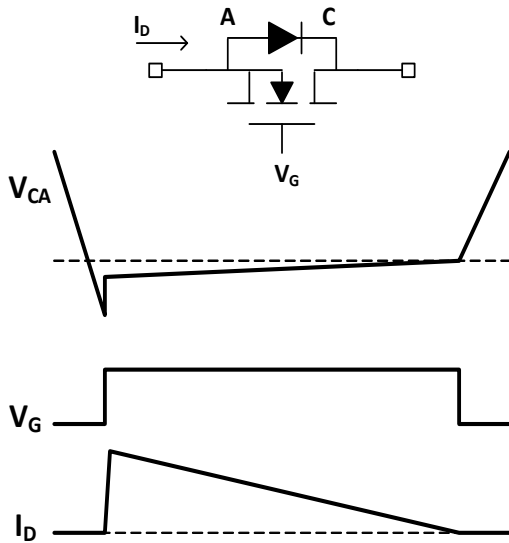

Figure 17. V_{CA} vs Switch Gate

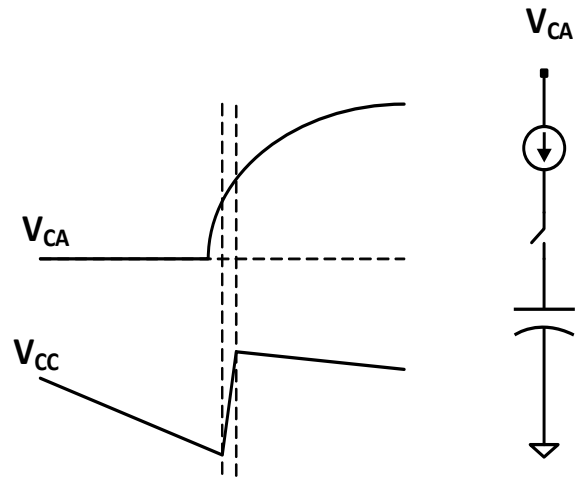

Figure 18. Charging V_{CC}

Suggested Application Circuits

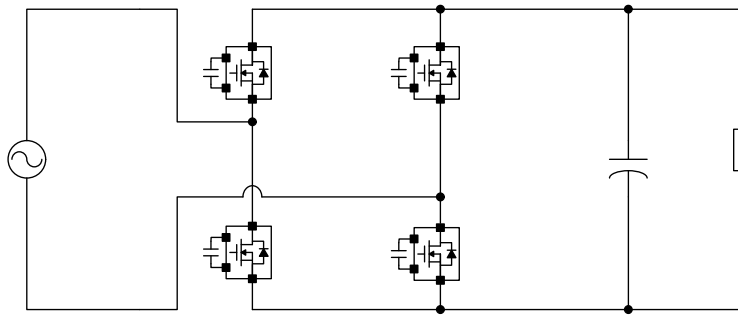

Figure 19. Application Circuit 1

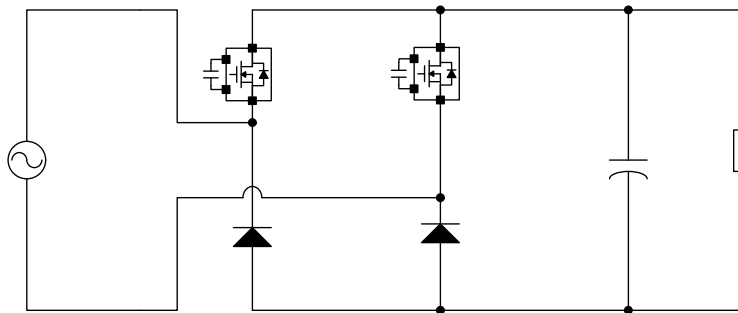

Figure 20. Application Circuit 2

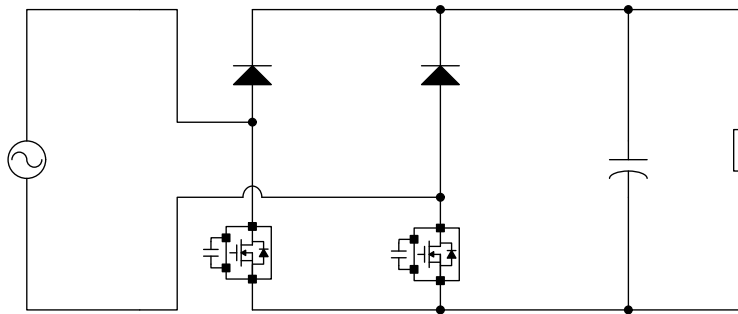

Figure 21. Application Circuit 3

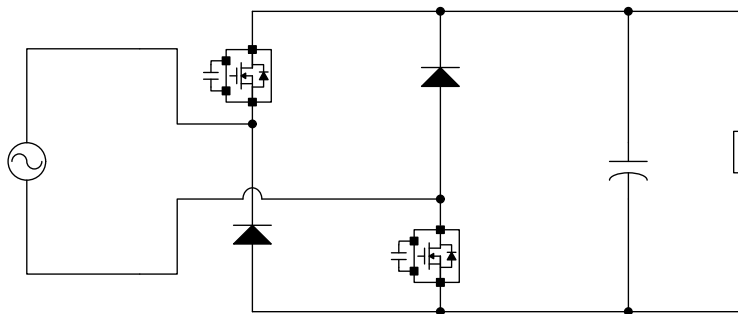

Figure 22. Application Circuit 4

Suggested Application Circuits

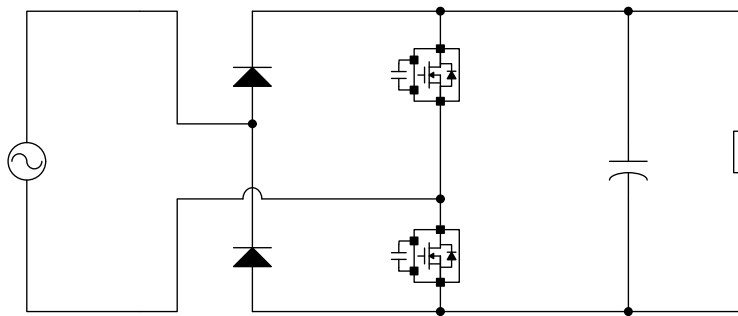

Figure 23. Application Circuit 5

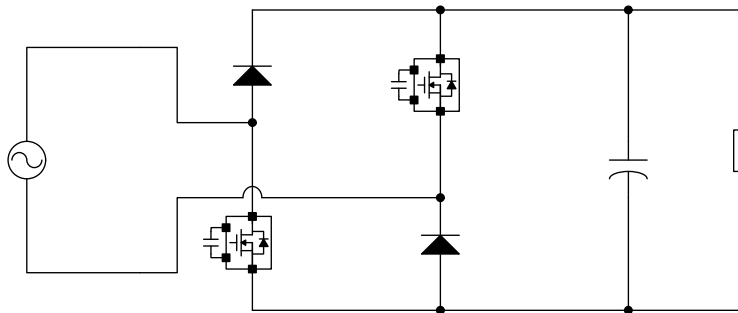

Figure 24. Application Circuit 6

Layout Guidelines

1. Large copper-clad and multi-layer PCB are recommended for cooling.
2. Don't place rectifier too close to AlphaZBL.
3. Adding VIAs on the exposed pad can let thermal pass through to other layer easily.
4. For MOSFET TC characteristic, the AlphaZBL must be as cool as possible.
5. If using Bridge and AlphaZBL together, split Bridge and AlphaZBL cooling areas.
6. AlphaZBL needs a large cooling copper-clad, and should not be placed too close to the Bridge Diode.
7. Bridge Rectifier diode needs the thermal higher than 80°C to reduce forward voltage (-2mV/°C), the thermal copper can be small.
8. The below example shows the bridge rectifier and AlphaZBL with split cooling areas, the thermal of Alpha ZBL can reduce about 10°C more than Bridge Diode.

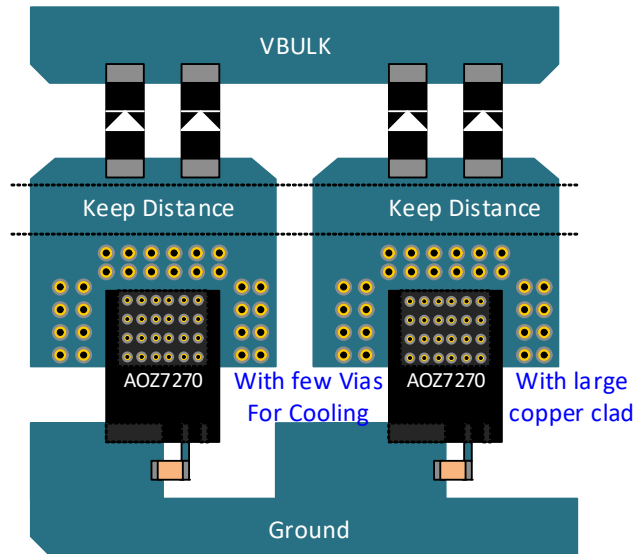
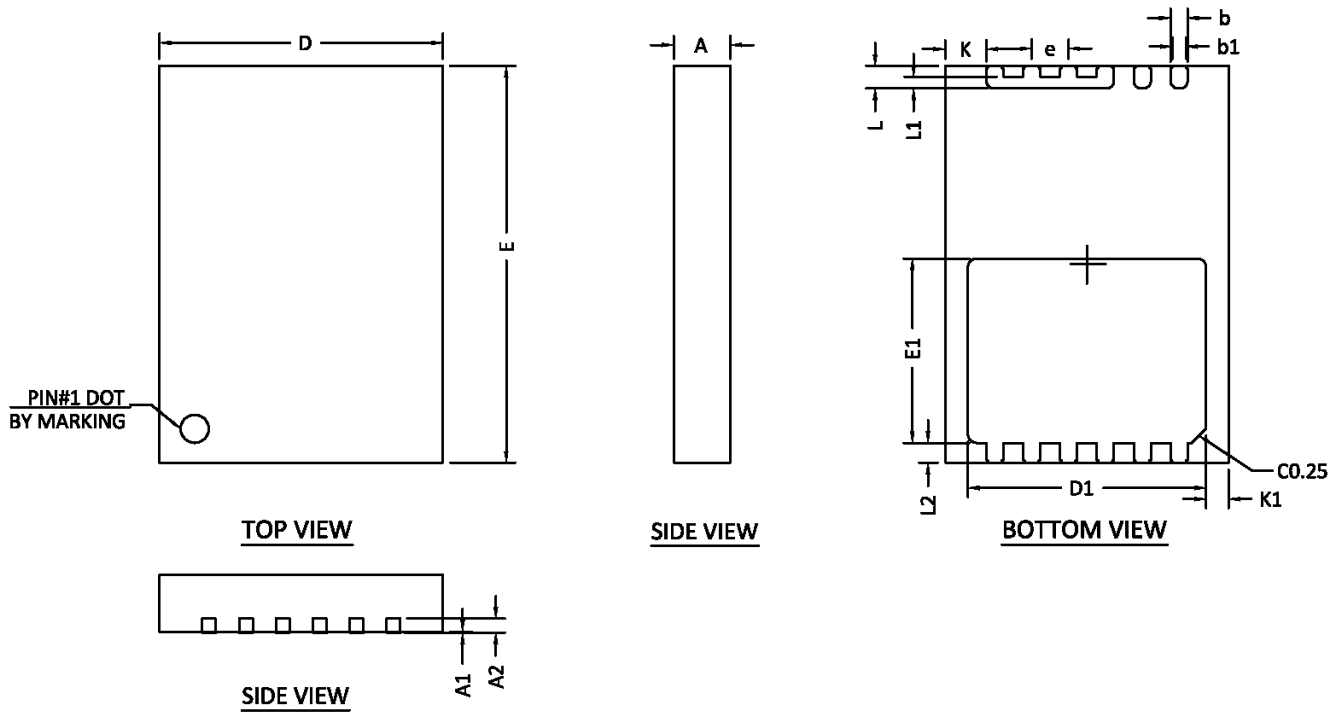
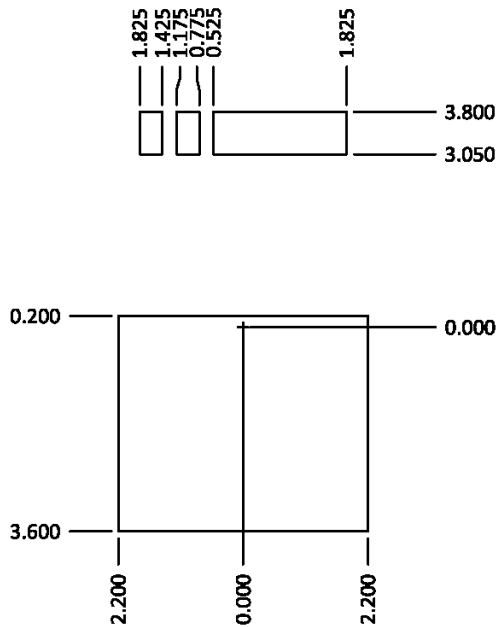

Figure 25. AOZ7270DI Evaluation Board Layout

Package Dimensions, DFN5x7-12L



RECOMMENDED LAND PATTERN



UNIT: mm

NOTE:
CONTROLLING DIMENSION IS MILLIMETER.
CONVERTED INCH DIMENSIONS ARE NOT NECESSARILY EXACT.

SYMBOLS	DIMENSION IN MM			DIMENSION IN INCHES		
	MIN	NOM	MAX	MIN	NOM	MAX
A	0.85	0.95	1.05	0.033	0.037	0.041
A1	0.00	-	0.05	0.000	-	0.002
A2	0.25REF			0.010REF		
E	6.95	7.00	7.05	0.274	0.276	0.278
E1	3.20	3.25	3.30	0.126	0.128	0.130
D	4.90	5.00	5.10	0.193	0.197	0.201
D1	4.15	4.20	4.25	0.163	0.165	0.167
L	0.35	0.40	0.45	0.014	0.016	0.018
L1	0.15	0.20	0.25	0.006	0.008	0.010
L2	0.30	0.35	0.40	0.012	0.014	0.016
K	0.63	0.73	0.83	0.025	0.029	0.033
K1	0.35	0.40	0.45	0.014	0.016	0.018
b	0.25	0.30	0.35	0.010	0.012	0.014
b1	0.19	0.24	0.29	0.007	0.009	0.011
e	0.65BSC			0.025BSC		

Tape and Reel Dimensions, DFN5x7-12L

DFN5x7 12L EP1 S Carrier Tape

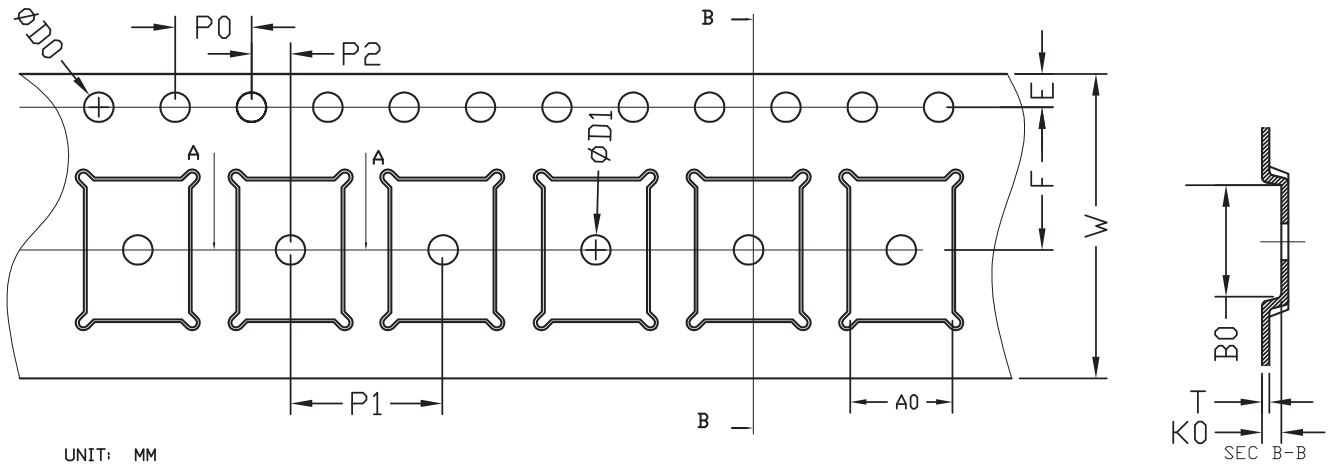

UNIT: MM

PACKAGE	A0	B0	K0	D0	D1	W	E	F	P0	P1	P2	T
DFN5x7	5.35 ±0.1	7.50 ±0.10	1.30 ±0.10	∅1.55 ±0.10	∅1.50 MIN.	16.00 ±0.3	1.75 ±0.10	7.50 ±0.10	4.00 ±0.10	8.00 ±0.10	2.00 ±0.10	0.30 ±0.05

DFN5x7 12L EP1 S Reel

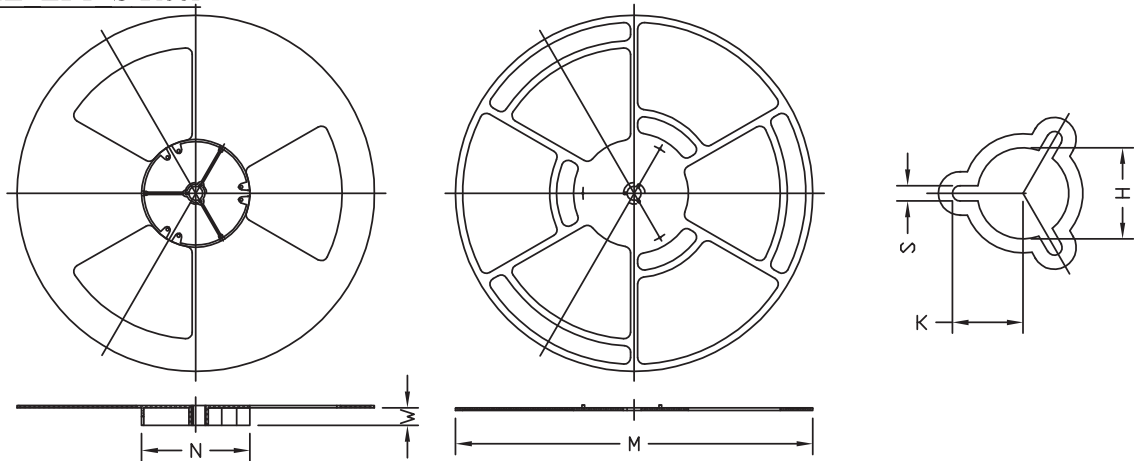

UNIT: MM

TAPE SIZE	REEL SIZE	M	N	W	H	K	S
16 mm	∅330	∅330.00 +0.25 -4.00	∅100.00 ±0.2	16.4 +2.0 -0.0	∅13.00 +0.50 -0.20	10.5 ±0.25	2.2 ±0.25

DFN5x7 12L EP1 S Tape

Leader / Trailer
& Orientation

Unit Per Reel:
3000pcs

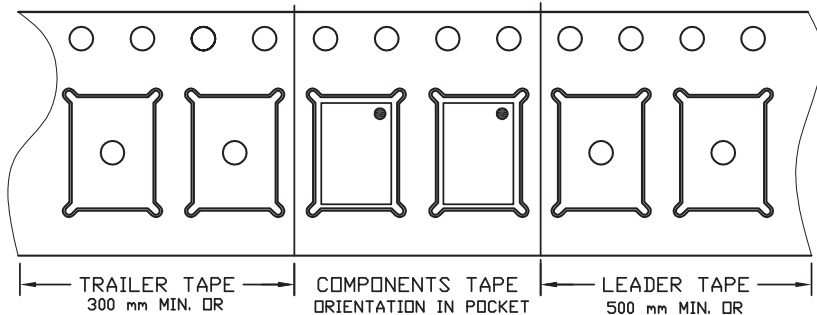

Part Marking

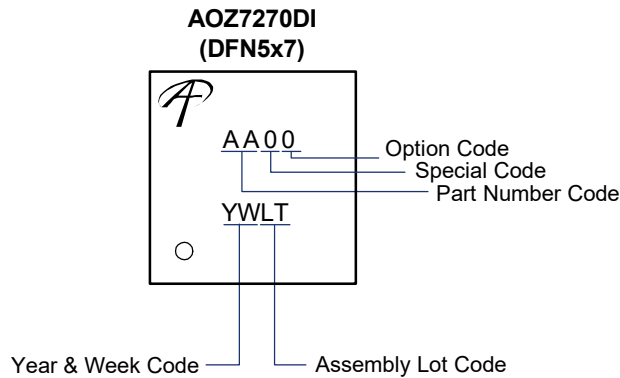

LEGAL DISCLAIMER

Applications or uses as critical components in life support devices or systems are not authorized. AOS does not assume any liability arising out of such applications or uses of its products. AOS reserves the right to make changes to product specifications without notice. It is the responsibility of the customer to evaluate suitability of the product for their intended application. Customer shall comply with applicable legal requirements, including all applicable export control rules, regulations and limitations.

AOS' products are provided subject to AOS' terms and conditions of sale which are set forth at:
http://www.aosmd.com/terms_and_conditions_of_sale

LIFE SUPPORT POLICY

ALPHA AND OMEGA SEMICONDUCTOR PRODUCTS ARE NOT AUTHORIZED FOR USE AS CRITICAL COMPONENTS IN LIFE SUPPORT DEVICES OR SYSTEMS.

As used herein:

- | | |
|---|---|
| <p>1. Life support devices or systems are devices or systems which, (a) are intended for surgical implant into the body or (b) support or sustain life, and (c) whose failure to perform when properly used in accordance with instructions for use provided in the labeling, can be reasonably expected to result in a significant injury of the user.</p> | <p>2. A critical component in any component of a life support, device, or system whose failure to perform can be reasonably expected to cause the failure of the life support device or system, or to affect its safety or effectiveness.</p> |
|---|---|