

This document is the property of Amphenol Corporation and is delivered on the express condition that it not be disclosed, reproduced or used, in whole or in part, for manufacture or sale by anyone other than Amphenol Corporation without its prior consent, and that no right is granted to disclose or to use any information in this document.

The marking on this product doesn't contain environmental hazardous material and must follow one or more specifications per Material Specification SS-00259 for Sony GP compliant or per directive 2011/65/EC for RoHS compliant or per IEC 61249-2-21 for Halogen Free compliant.



ORIGINAL



REVISIONS				
SYM	ECN No.	DESCRIPTION	DATE	BY
F	NE-13115	MODIFIED PACKING DRAWING	07/16/2013	Sondra Sang
A1	NE-14150	CHANGED REEL	08/13/2014	Sondra Sang

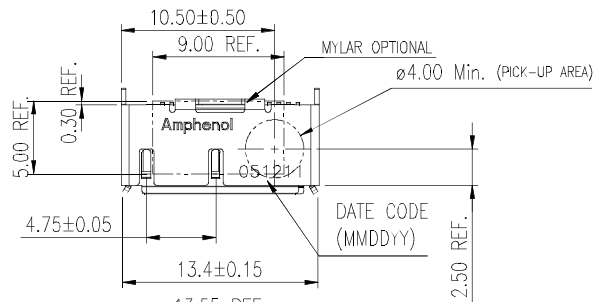

PART NUMBER:
GSB3 43T 3 3 X HR

CONTACT FINISH:
3: 30µ" GOLD

VARIATION CODE
BLANK: STANDARD T&R PACKING
A: W/ MYLAR, T&R PACKING

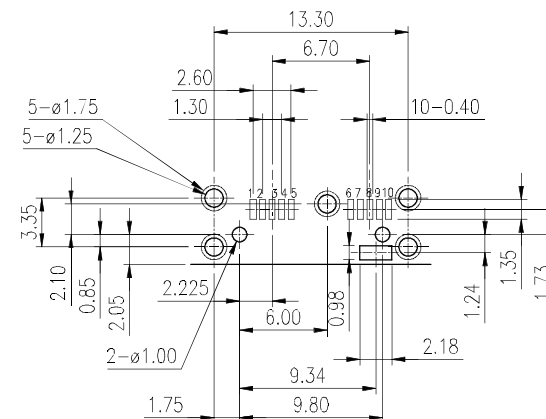
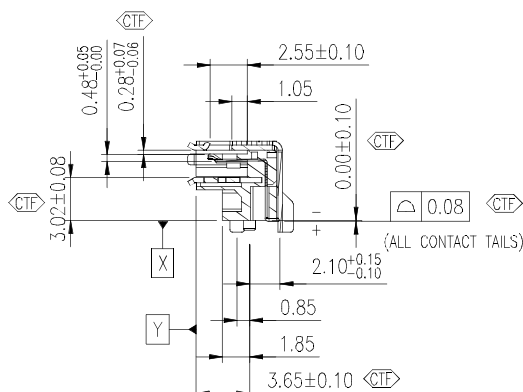
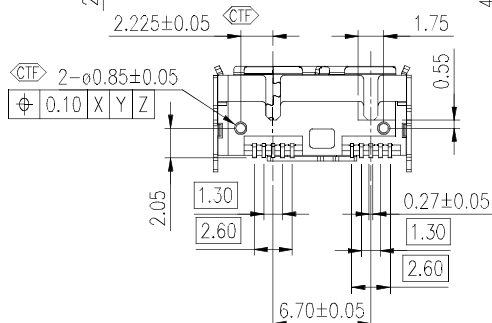
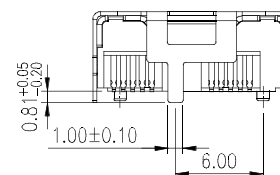
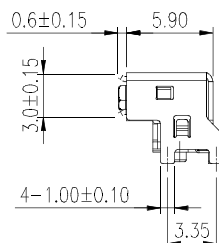
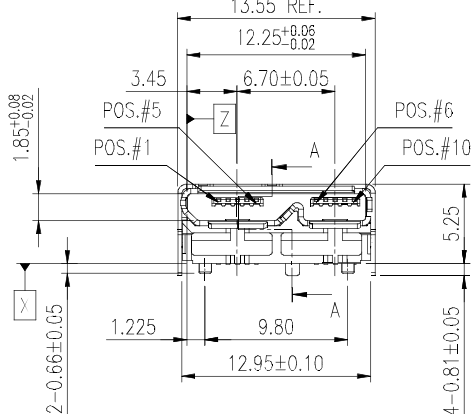
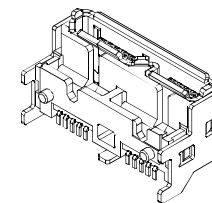
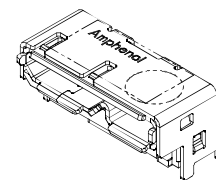

RECOMMENDED PCB LAYOUT - TOP VIEW
(GENERAL TOLERANCE: ±0.05)

NOTES:

- HOUSING: HIGH TEMP. THERMOPLASTIC, UL 94V-0, COLOR- BLACK
- CONTACT: COPPER ALLOY, 0.15mm THICKNESS, 30µ" MIN. GOLD PLATED ON CONTACT AREA, 150µ" MATTE TIN PLATED ON SOLDERING TAIL, 80µ" MIN. NICKEL UNDER-PLATED OVERALL
- INNER SHELL: STAINLESS, 0.35mm THICKNESS
- OUTER SHELL: STAINLESS, 0.30mm THICKNESS, 50µ" MIN. NICKEL PLATED ON THE SOLDERING TAILS
- CTF ARE THE CRITICAL DIMENSIONS MUST BE INSPECTED BY SPC.
- PACKING: PLEASE REFER TO PKS-GSB343PT01HR
- THIS PRODUCT DOESN'T CONTAIN ENVIRONMENTAL HAZARDOUS MATERIALS PER DIRECTIVE 2002/95/EC FOR RoHS AND PER IEC 61249-2-21 FOR HALOGEN FREE COMPLIANT.

TOLERANCE	APPROVALS	DATE	TITLE		
X. ±0.30	DRAWN Sondra Sang	8/13/2014	USB 3.0 CONNECTOR MICRO_B, RECEPTACLE R/A SMT, HIGHT RISE		
X.X ±0.20	CHECKED Chenny Yeh	8/13/2014			
X.XX ±0.10	APPROVED Hank Hsu	8/13/2014			
ANGULAR ±1°	DWG TYPE CUST DWG	PROJECT CODE T512			
UNLESS OTHERWISE SPECIFIED			UNIT mm	SIZE A3	PART No. GSB3 43T 33X HR
			SCALE NA	SHEET 1 OF 1	DWG No. GSB343T33HR
					REV. A1

Amphenol®

Amphenol Corporation
Amphenol Taiwan Corporation

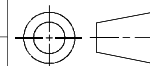

UNIT mm
SCALE NA

SIZE A3
SHEET 1 OF 1

PART No. GSB3 43T 33X HR
DVG No. GSB343T33HR

REV. A1

This document is the property of Amphenol Corporation and is delivered on the express condition that it is not to be disclosed, reproduced or used, in whole or in part, for manufacture or sale by anyone other than Amphenol Corporation without its prior consent, and that no right is granted to disclose or to use any information in this document.
The marking on this product doesn't contain environmental hazardous material and must follow one or more specifications per Material Specification SS-00259 for Sony GP compliant or per directive 2011/65/EC for RoHS compliant or per IEC 61249-2-21 for Halogen Free compliant.



ORIGINAL



REVISIONS				
SYM	ECN No.	DESCRIPTION	DATE	BY
F	NE-13115	MODIFIED PACKING DRAWING	07/16/2013	Sondra Sang
A1	NE-14150	CHANGED REEL	08/13/2014	Sondra Sang

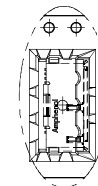
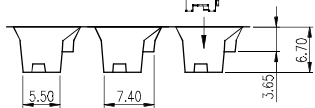
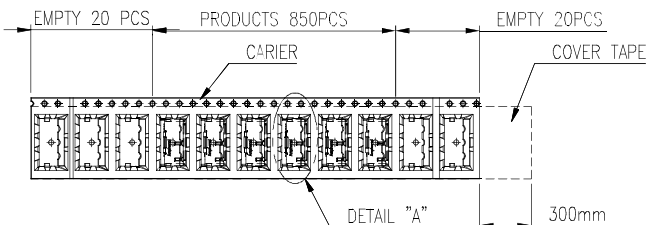
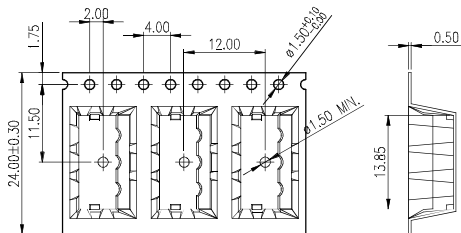

DETAIL "A"

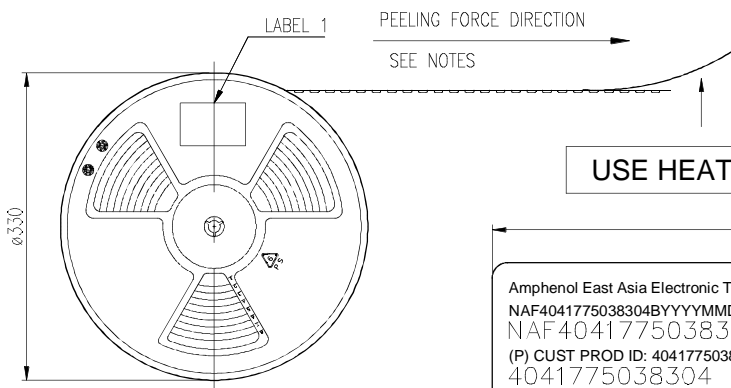

LABEL 1 = Q'TY : Q850
LABEL 2 = Q'TY : Q10200

Amphenol East Asia Electronic Technology(Shen Zhen)Co., Ltd.
NAF4041775038304BYYYYMMDD
NAF4041775038304B20120101
(P) CUST PROD ID: 4041775038304
4041775038304
(Q) QUANTITY: 850 (T) DATE CODE: YYYYMMDD
850 *YYYYMMDD*
(1T) LOT CODE: 102711
123456
(1P) Amphenol P/N: GSB343T33HR
GSB343T33HR
**RoHS & HF
Compliant**

LABEL1 & LABEL2

PART NO.	PCS./REEL-T1	PCS/CARTON-T2	N.W.	G.W.
GSB343TXXHR	850 PCS.	850X12=10200 PCS.	*	*

("**") FOR REFERENCE

NOTES:

- MATERIAL: CONDUCTIVE POLYSTYRENE ALLOY, COLOR- BLACK
- THICKNESS: 0.50±0.05 mm
- TAPE HAVE TO USE HEAT SEAL TYPE
- ALL DIMENSIONS MEET EIA-481-C REQUIREMENTS
- COMPONENT LOAD PER 13" REEL: 850 PCS.
- LABEL: 3 OF 9 CODE OR 128 CODE
- THIS PRODUCT DOESN'T CONTAIN ENVIRONMENTAL HAZARDOUS MATERIALS PER DIRECTIVE 2002/95/EC FOR RoHS COMPLIANT.

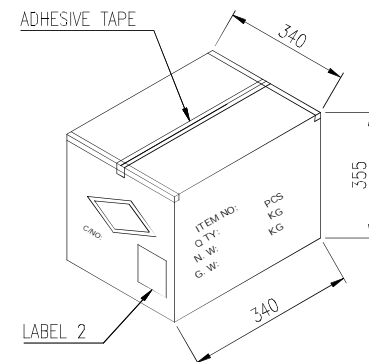
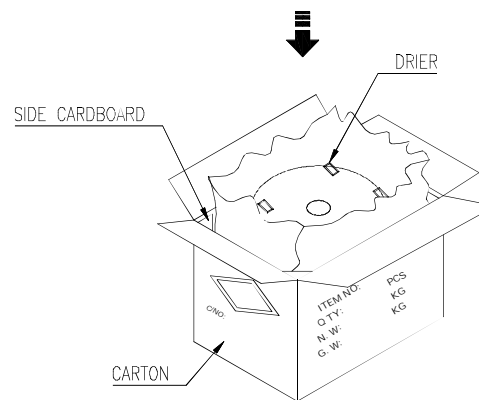
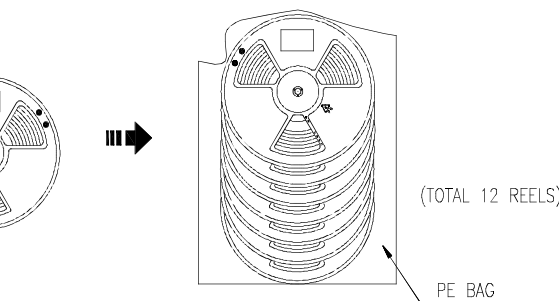

TOLERANCE	APPROVALS	DATE	TITLE		UNIT		SIZE	PART No.
X. ±0.20	DESIGNED: Sondra Sang	8/13/2014	USB3.0 CONNECTOR MICRO_B, HI-RISE RECEPT, R/A SMT TYPE		mm	A3	PKS-GSB343PT01HR	
X.X ±0.15	CHECKED: Chenny Yeh	8/13/2014						
X.XX ±0.10	APPROVED: Hank Hsu	8/13/2014	UNLESS OTHERWISE SPECIFIED		SCALE: NA	SHEET: 2 OF 2	DVG No: PKS-GSB343PT01HR	
X.XXX ±0.05	DWG TYPE: CUST DWG	PROJECT CODE: T512						REV: A1

Amphenol®

Amphenol Corporation
Amphenol Taiwan Corporation

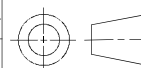

UNIT: mm
SCALE: NA
SIZE: A3
SHEET: 2 OF 2

PART No. PKS-GSB343PT01HR
DVG No. PKS-GSB343PT01HR
REV: A1