



A Product Line of
Diodes Incorporated



SPECIFICATION FOR APPROVAL

CUSTOMER _____

NOMINAL FREQUENCY 6.000000 MHz

PRODUCT TYPE **TYPE F8 8.0x4.5 GLASS SEALED CRYSTAL**

SPEC. NO. (P/N) F80600004

CUSTOMER P/N _____

ISSUE DATE January 3, 2018

VERSION C

APPROVED	PREPARED	QA
<i>Brenda</i>	<i>Kelly</i>	<i>Song Yang</i>

Diodes Incorporated

No.2, Ziqiang 5th Rd., Zhongli Industrial Park,
Zhongli Dist., Taoyuan City 32063, Taiwan (R.O.C.)
TEL: 886-3-451-8888
FAX: 886-3-461-3865
<https://www.diodes.com>

*RoHS Exemption
*HF-Halogen Free
*REACH Compliant

TYPE F8 8.0x4.5 GLASS SEALED CRYSTAL

F80600004

VER. C 3-Jan-18

VERSION HISTORY

Version No.	Version Date	Description	Notes
A	Jun.2,2009	Initial Release	
B	Jul.5,2013	Updated Suggested IR Reflow Profile, Format & Logo	
C	Jan.3,2018	Updated logo	



TYPE F8 8.0x4.5 GLASS SEALED CRYSTAL

F80600004

VER. C 3-Jan-18

ELECTRICAL SPECIFICATIONS

Item	Symbol	Specifications	Units	Notes
Nominal Frequency	Fn	6.000000	MHz	
Mode of Oscillation	MO	AT Cut-Fundamental		
Calibration Load Capacitance	CL	18	pF	
Calibration Tolerance	FL	±30	ppm	at 25°C±3°C
Operating Temperature Range	TR	-20 to +70	°C	
Frequency Stability (Frequency Deviation over the Operating Temperature Range)	F/T	±30	ppm	Reference to the Frequency at 25°C
Operating Drive Level		10	µW	
Equivalent Series Resistance	ESR	100	Ω	Max
Shunt Capacitance	C0	5	pF	Max.
Aging at 25°C		±3	ppm	Max, 1st year
Storage Temperature		-55 to +125	°C	
Insulation Resistance		500	MΩ	Min

TYPE F8 8.0x4.5 GLASS SEALED CRYSTAL

F80600004

VER. C 3-Jan-18

RELIABILITY SPECIFICATIONS

MECHANICAL AND ENVIRONMENTAL RATINGS:

- a) FINE LEAK TEST: JESD22-A109 (Condition 1A)
- b) GROSS LEAK TEST: JESD22-A109 (Condition C)
- c) MOISTURE RESISTANCE: JESD22-A113
- d) SHOCK: JESD22-B104 (Condition B)
- e) SOLDERABILITY : (RoHS version): J-STD-002
- f) VIBRATION: JESD22-B103
- g) SOLVENT RESISTANCE: JESD22-B107
- h) RESISTANCE TO SOLDERING HEAT (RoHS version): J-STD-020D Table 5.2 Pb free devices (3 cycles max)

SUGGESTED IR REFLOW PROFILE

*As per IPC-JEDEC J-STD-020D

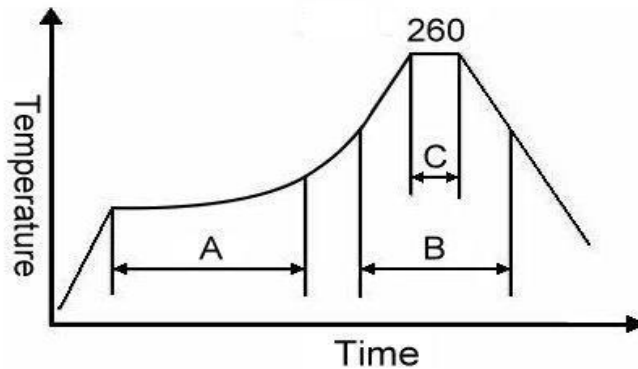

Note:

	Stage	Temperature	Time
A	Preheat	150~200°C	60~120 Sec
B	Primary Heat	217°C	60~150 Sec
C	Peak	260°C	10 Sec

TYPE F8 8.0x4.5 GLASS SEALED CRYSTAL

F80600004

VER. C 3-Jan-18

MARKING

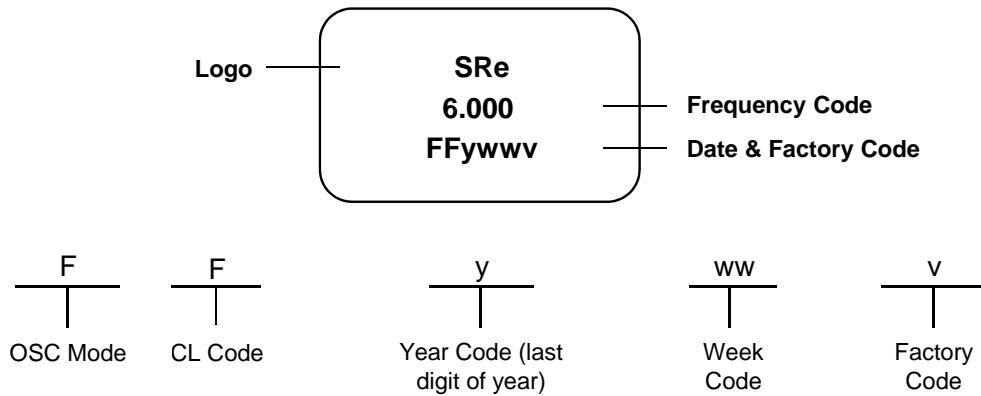

MECHANICAL DRAWINGS (Scale: None. Dimensions are in mm.)

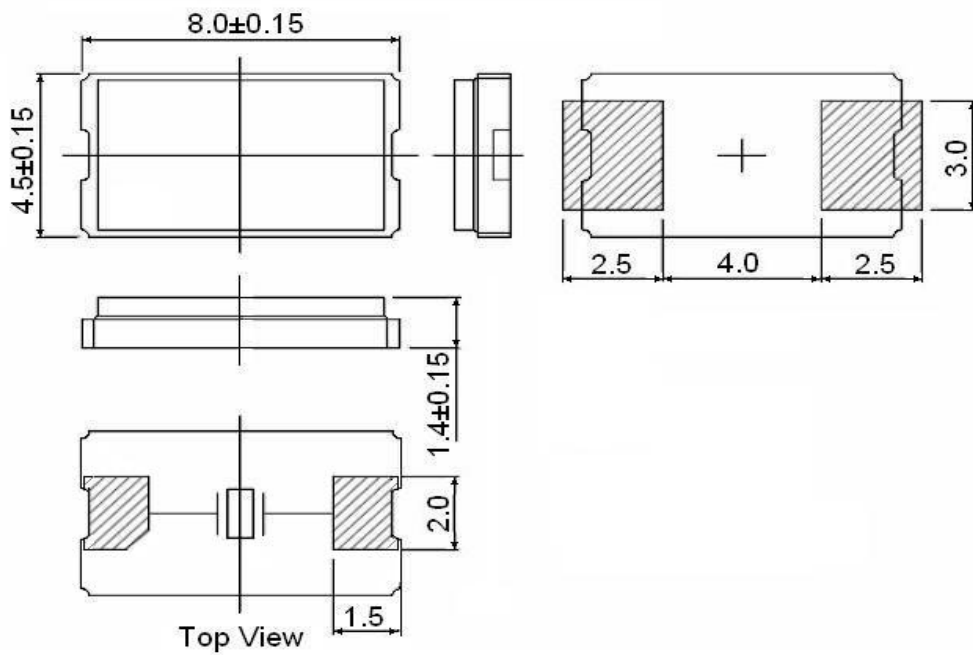

TYPE F8 8.0x4.5 GLASS SEALED CRYSTAL

F80600004

VER. C 3-Jan-18

Tape & Reel

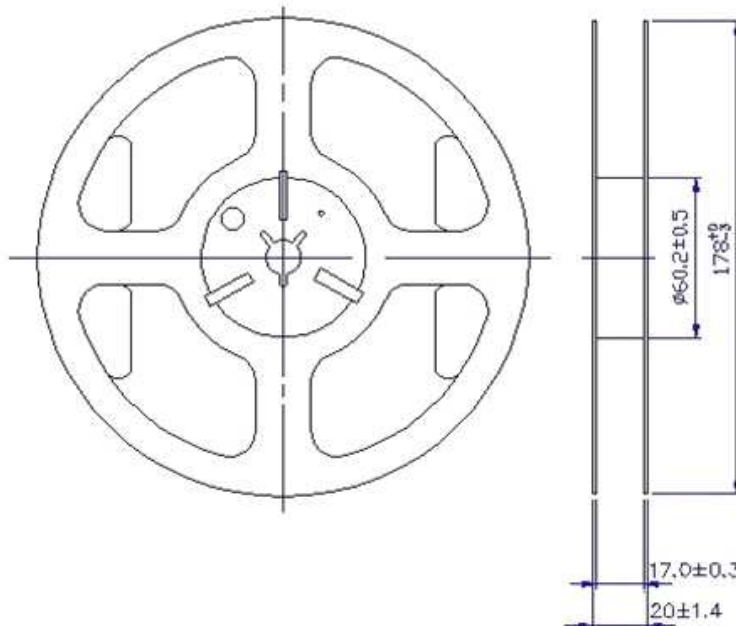
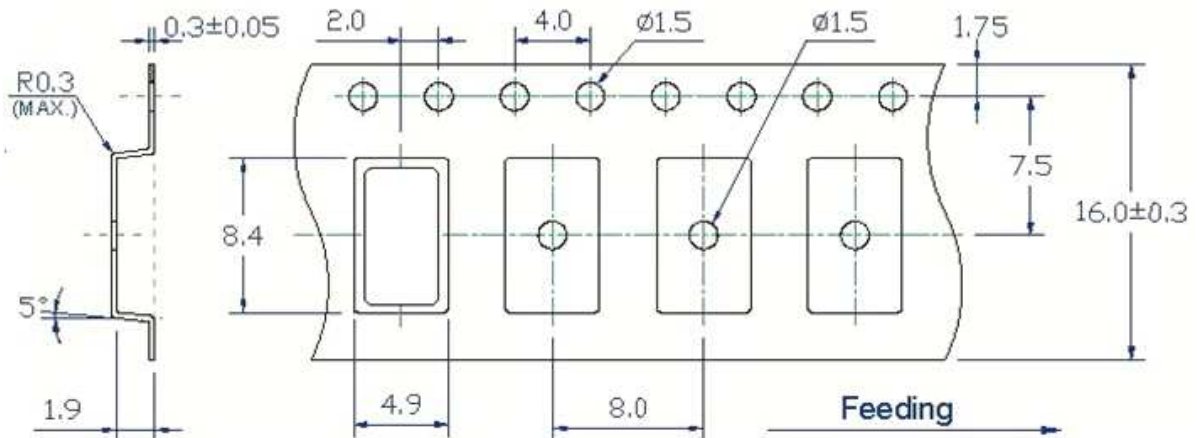

1. 230mm minimum leader which consist of carrier and/or tape followed by a minimum of 160mm of empty carrier tape sealed with cover tape.
2. 160mm minimum trailer of empty carrier tape sealed with cover tape.

TYPE F8 8.0x4.5 GLASS SEALED CRYSTAL

F80600004

VER. C 3-Jan-18

PACKING

