



Atop Technologies, Inc.

Smart MACSec Gigabit Ethernet Switch

EHG2408 Series

Hardware Installation Guide

Version 1.0
Updated in November, 2017



Tel: 886-3-5508137
Fax: 886-3-5508131
www.atop.com.tw

P/N : 89900515G

Package Check List

Inside the package you will find the following items:

- Smart MACSec Gigabit Ethernet Switch x 1
- 5-Pin 5.08mm Lockable Terminal Block x 1
- DIN-Rail Kit (Already mounted to the device) x 1
- Protective caps for all SFP (Depend on purchased model)
- Installation Guide with Warranty Card x 1



Never install or work on electrical or cabling during periods of lightning activity. Never connect or disconnect power when hazardous gases are present.



Warning: Hot Surface Do Not Touch. RESTRICTED ACCESS AREA: The equipment should only be installed in a Restricted Access Area.



Caution: CLASS 1 LASER PRODUCT. Do not stare into the laser!



This equipment should be installed indoor and not connect directly with equipment installed outdoor.

Product Layout

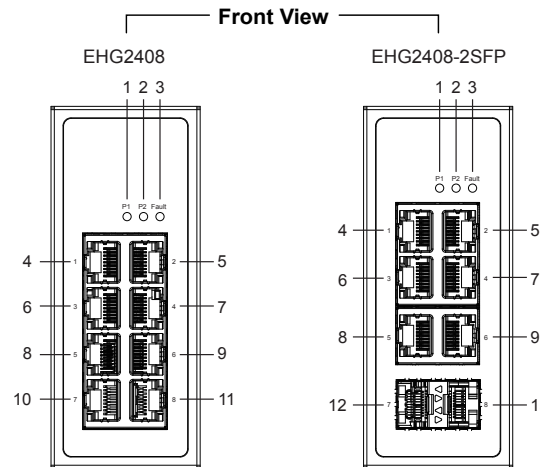

- | | |
|--------------|---|
| 1. PWR1 LED | 4 ~ 9. 10/100/1000 BASE-T(X) RJ45 Ports |
| 2. PWR2 LED | 10 ~ 11. 10/100/1000 BASE-T(X) RJ45 Ports with MACSec |
| 3. Fault LED | 12 ~ 13. 1000 BASE-X SFP Slots with MACSec |

Top View

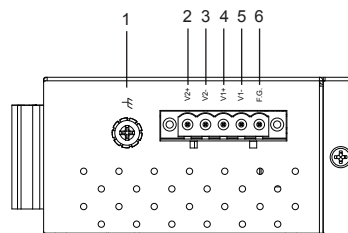

1. Grounding Screw
- 2 ~ 3. Terminal for Power 2
- 4 ~ 5. Terminal for Power 1
6. Functional Ground

Installation Overview

The device's appearance is as in the figure below.

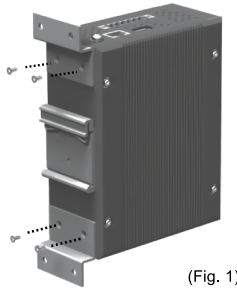

(Fig. 1)

1. If you have purchased the wall mount kit, proceed to place the screws on the back of the device as show in (Fig. 1).
2. Although internal grounding has been done inside, in order to ensure overall maximum performance and protect your device, it is still strongly advised to ground the device properly; hazardous ESD can come into contact and damage your equipment. On the power terminal block, there is a terminal for Frame Ground, you can choose whether to connect it to the grounding or you may opt to connect to the grounding screw next to the terminal block (the one chosen should be connected at all times) (Fig. 2)

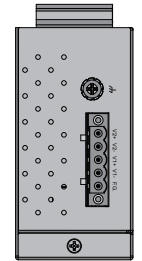

(Fig. 2)

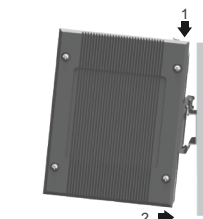

(Fig. 3)

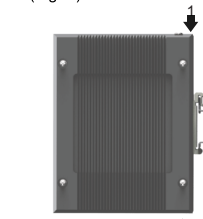

(Fig. 4)

3. You can then choose whether to plug in the other peripheral ports at this point or do it later depending on the actual location of the device or level of comfort for performing such operation.

Remember to plug in the protective caps for the unused SFP.

4. Once the plate has been firmly put in place, proceed to mount the whole device as shown in (Fig. 3). Proceed to (Fig. 4) if you want to remove the device from DIN-Rail.

5. Next we can then proceed to connect the device to the LAN (switch or PC, depending on the case), take care on using the RJ-45 connector; after this we can then proceed to the device's settings

■ The opening to the sides are for the device's heat dissipation please never obstruct or cover them with any objects or try to insert them through it.

■ This switch's factory IP by default is 10.0.50.1 you can access the device by its Web UI once it is connected to a physical network (or using Management Utility, for more information on Management Utility, please refer to its manual). Please be aware that the PC needed for this procedure needs to be in the same subnet, or you may refer yourself to the device User's Manual.

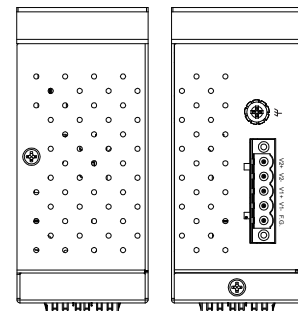

LED Indicators

LED	Color	State	Description
PWR1	Green	On	Power is supplied through PWR1
PWR2		Off	Power is supplied through PWR2
Fault	Red	On	PWR1 or PWR2 is abnormal
		Off	PWR1 and PWR2 are normal
SFP	Green	On	SFP is connected
LAN	Amber	On	Ethernet is linked at 1000Mbps
		Off	Ethernet is linked at 10Mbps or not linked
	Green	On	Ethernet is connected
		Blinking	Data is being transmitted
		Off	Ethernet is disconnected

Power Requirements

Power input : 9-48 VDC, 0.64A Max

Pin Assignments and Connections

10/100/1000BASE-T(X) Ethernet Pinouts

RJ-45								
10/100BASE-T(X)								
Pin	1	2	3	4	5	6	7	8
Signal	Tx+	Tx-	Rx+			Rx-		
1000BASE-T								
Pin	1	2	3	4	5	6	7	8
Signal	BI_DA+	BI_DA-	BI_DB+	BI_DC+	BI_DC-	BI_DB-	BI_DD+	BI_DD-

1000BASE-X Fiber Optics SFP Slot

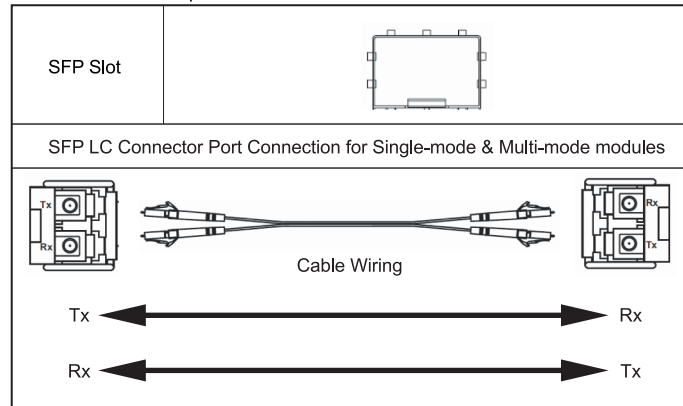

Caution

The SFP slot should be used in conjunction with a MSA compliant optical transceiver.

Field Maintenance and Service

If the device requires servicing of any kind, you may need to disconnect and remove it from its mounting. The initial installation should be done in a way that makes this as convenient as possible.

- Voltage/Power lines should be properly insulated as well as other cables. Be careful when handling the so as to not trip over
- Do not under any circumstance insert foreign objects of any kind into the heat dissipation holes located in the different faces of the device. This may not only harm the internal layout but might cause harm to you as well.
- Do not under any circumstance open the device for any reason. Please contact your dealer for any repair needed or follow the instructions on section of your User's Manual.

Mechanical Dimensions (Unit=mm)

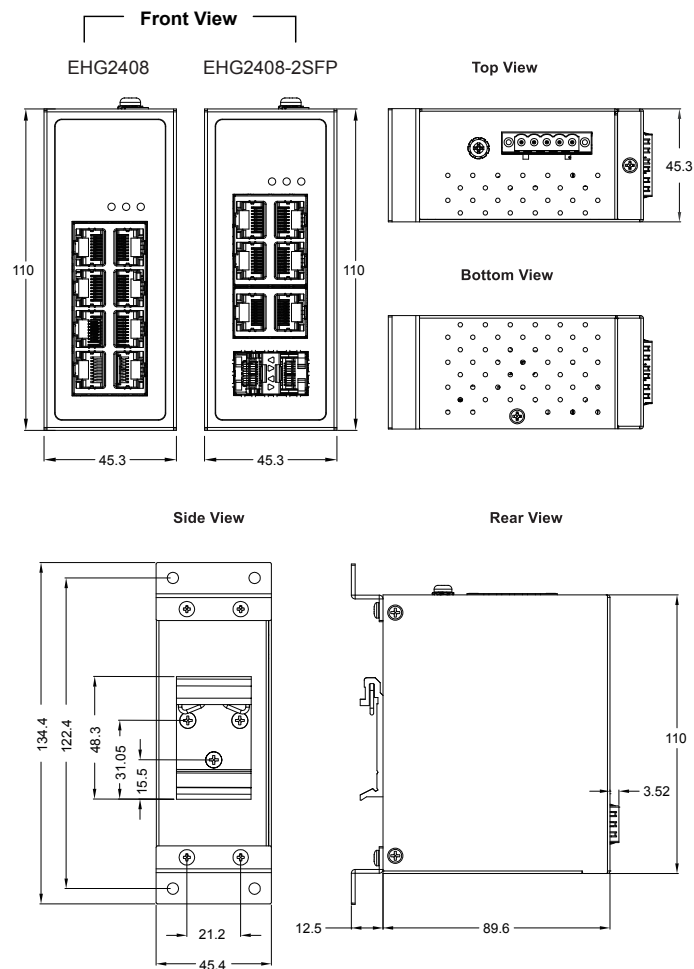

※ The wall mount kit illustrated in this document is for reference only and is not included in the package.

Warranty Policy

Warranty Conditions

Products supplied by Atop Technologies are covered in this warranty for sub-standard performance or defective workmanship. The warranty is not, however, extended to goods damaged in the following circumstances:

- Excessive forces or impacts
- War or an Act of God: wind storm, fire, flood, electric shock, earthquake
- Use of unqualified power supply, connectors, or unauthorized parts/kits
- Replacement with unauthorized parts

RMA and Shipping Costs Reimbursement

Customers shall always obtain an authorized "RMA" number from Atop before shipping the goods to be repaired to Atop. When in normal use, a sold product shall be replaced with a new one within 3 months after purchase. The shipping cost from the customer to Atop will be reimbursed by Atop.

After 3 months and still within the warranty period, it is up to Atop whether to replace the unit with a new one; normally, as long as a product is under warranty, all parts and labor are free of charge to the customers.

After the warranty period, the customer shall cover the cost for parts and labor. Three months after purchase, the shipping cost from the customer to Atop will not be reimbursed, but the shipping cost from Atop to the customer will be paid by Atop.

Limited Liability

Atop shall not be held responsible for any consequential losses from using Atop's product.

Warranty Period

Product Categories	Warranty	Product Categories	Warranty
Ethernet Switches	5 Years	DIN-Rail Power Supplies	3 Years
Wireless		Power Adaptors	1 Year
Serial Device Servers		Antennas	
Modbus Gateways		Other Accessories	
Media Converters			
Embedded Device Servers			

The warranty certification will not be effective until an authorized stamp issued by Atop's overseas agents.

Purchase Date: / / (yyyy/mm/dd)

Serial Number



Atop Customer Services and Supports

- Please contact your local dealers or Atop Technical Support Center at the following numbers.
+ 886-3-550-8137 (Atop Taiwan)
+ 86-21-6495-6232 (Atop China)
- Please report the defected problems via Atop's Web site or E-mail account
Web Site : www.atop.com.tw, e-mail : service@atop.com.tw
Web Site : www.atop.com.cn, e-mail : service@atop.com.cn

— Any changes to this material will be announced on Atop website. —