

THIS DOCUMENT IS THE PROPERTY OF KEYSTONE ELECTRONICS CORP. AND SHALL NOT BE REPRODUCED, DISTRIBUTED OR USED AS A BASIS FOR MANUFACTURE WITHOUT PRIOR WRITTEN PERMISSION FROM KEYSTONE ELECTRONICS CORP.

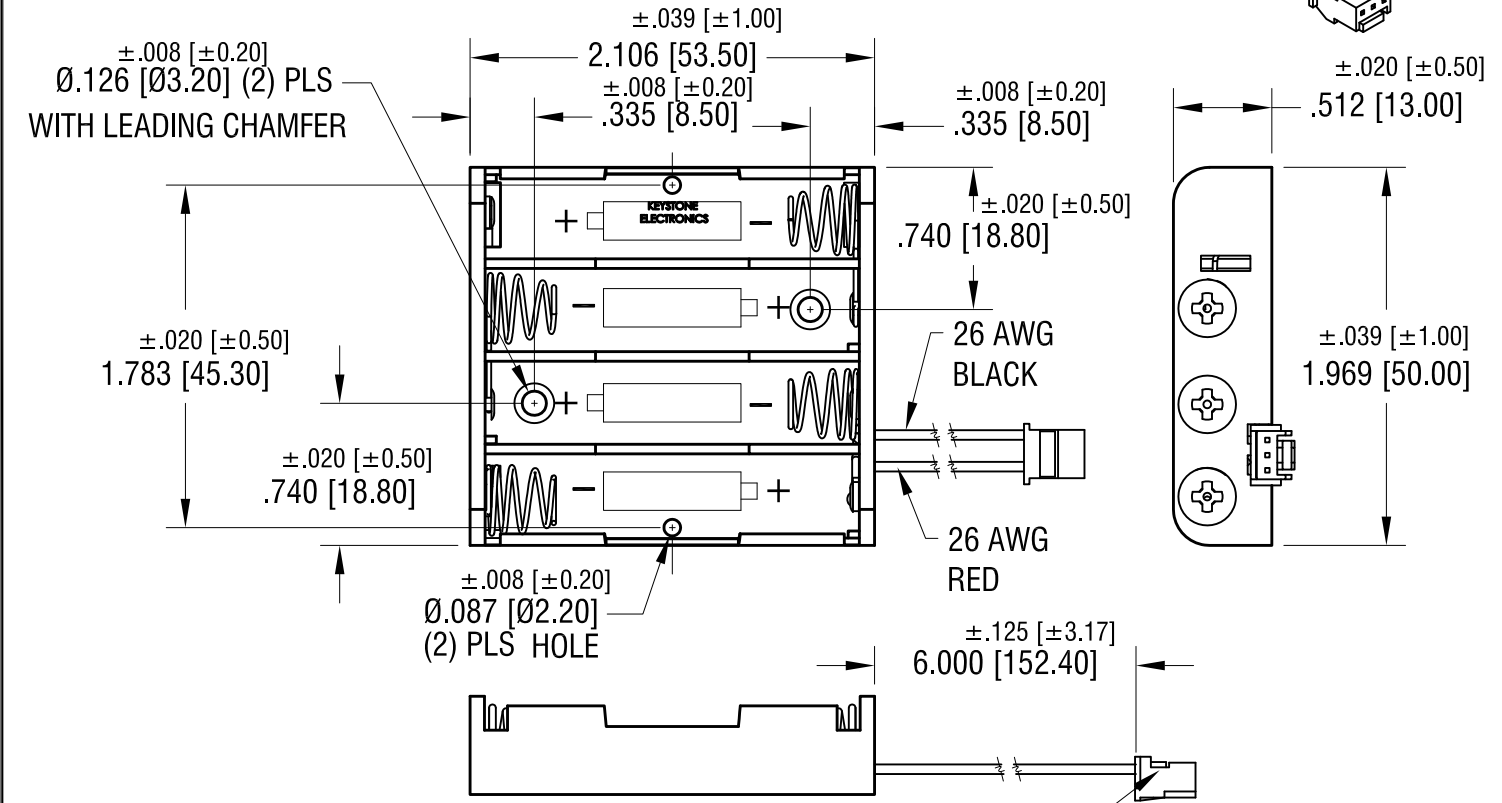
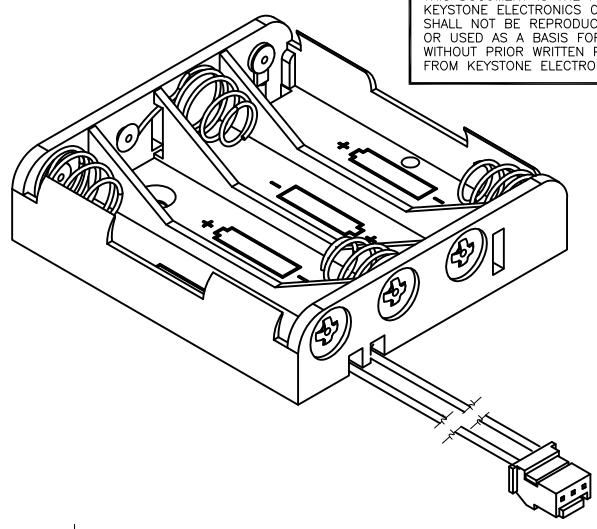
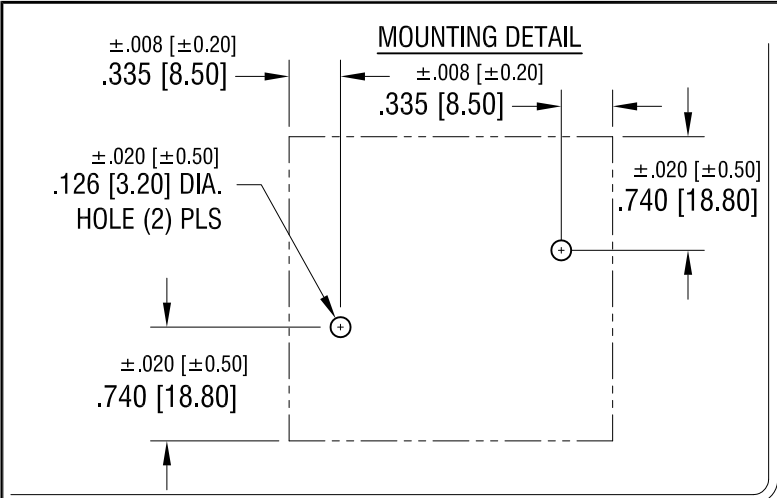

\* JST PA CONNECTOR OR EQUIVALENT

\*USE : P/N'S 974,975, 976 OR 977 FOR P.C. CONNECTOR

**NOTE:**

1. HOLDER: MAT'L: POLYPROPYLENE
2. SPRING: MAT'L: MUSIC WIRE, .024 [0.60] DIA. FINISH: NICKEL PLATE
3. CONNECTOR: MAT'L - PA 66, UL94V-0 COLOR- NATURAL
4. POSITIVE (RED) CONNECTED TO PIN 1  
NEGATIVE (BLACK) CONNECTED TO PIN 3

<b>KEYSTONE ELECTRONICS CORP.</b>			
www.keyelco.com • NEW HYDE PARK, NY 11040 • Tel (516) 328-7500			
PART NAME		BATTERY HOLDER (4) 'AAA'	
MATERIAL AS NOTED			
FINISH AS NOTED		DRN BY NT	DATE 4.08.16
		APP'D RH	SCALE 1X
TOLERANCES INCH [MM]	CODE	DWG NO.	
DECIMAL ±.015 [±0.38]	C	<b>2482CN</b>	
ANGULAR ± 1° UNLESS OTHERWISE SPECIFIED			

10.24.18	CHANGE AS PER ECN 18-045	A
DATE	DESCRIPTION	REV.