

## Data sheet

**M12 Sensor/actuator cable, A-coded, 5.0 m,  
M12 jack straight - M12 jack straight,  
unshielded, 5-pole, PUR**

Page 1/7

P/N  
**142MDA22050**  
EAN 4251394648279  
2022/03/14  
Version: E

### Illustrations



Dimensional drawing

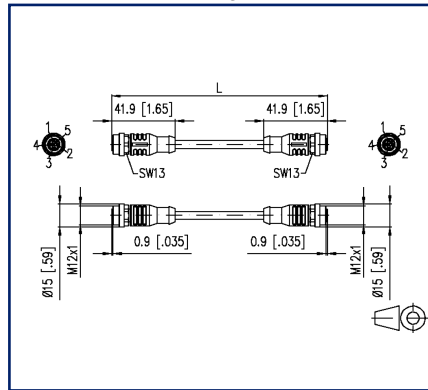

Wiring diagram

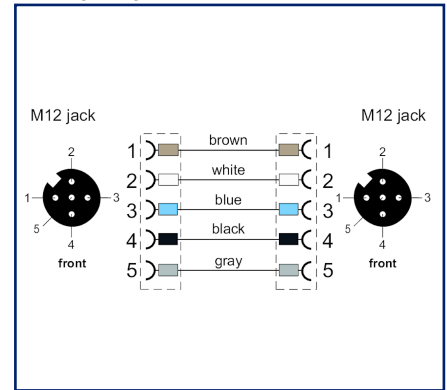

See enlarged drawings at the end of document

### Product specification

Flexible, silicone- and halogen-free control cable with high mechanical strength. The cable is resistant to chemicals, hydrolysis and microbes. The drag-chain application is possible at a bending radius of minimum 10xd. Due to its weld-field immunity, the cable is very well suited for the flexible application in robotics, machine tools and metal-cutting production. The cables meet the UL and CSA (UL10493/20549; cULus) requirements. Special features: flame retardant, seawater resistant, recyclable, LABS free, RoHs compliant, acid and alkali resistant, ozone resistant, UV resistant, hydrolysis proof, drag chain resistant, torsion resistant, welding sparks resistant, halogen free, silicone free, oil resistant

- Standard variants: 1.0 m, 2.0 m, 5.0 m, 10.0 m.
- Other cable lengths on request.

# P | Cabling

## Data sheet

Page 2/7

### M12 Sensor/actuator cable, A-coded, 5.0 m, M12 jack straight - M12 jack straight, unshielded, 5-pole, PUR

P/N  
142MDA22050  
EAN 4251394648279  
2022/03/14  
Version: E

## Technical Data

### General Data

Fields of application	Industrial Ethernet
Design	Sensor/actuator connection line M12, A-coded
Shielding	unshielded
Transmission technology	Copper
Color coding fiber/ wire(s)	brown, white, blue, black, gray
Color	black
Dimensions	
Dimension - Interface 1 (L x W x H)	41.9 mm x 15 mm x 15 mm
Dimension - Interface 1 (L x W x H)	1.65 in. x 0.591 in. x 0.591 in.
Dimension - Interface 2 (L x W x H)	41.9 mm x 15 mm x 15 mm
Dimension - Interface 2 (L x W x H)	1.65 in. x 0.591 in. x 0.591 in.
Cable length (m)	5 m
Cable length (ft)	16.4 ft
Labeling option	identification label carrier

### Connections/interfaces

Connector technology interface 1	M12-jack
Connector technology interface 2	M12-jack
Coding interface 1	A-coded
Coding interface 2	A-coded
Number of positions/contacts interface 1	5
Number of positions/contacts interface 2	5
Termination data, stranded wire (min. - max.)	
Conductor cross section, stranded wire	AWG 22/42
Conductor cross section, stranded wire	0.34 mm <sup>2</sup>
Stranded wire structure	42x0.10mm



# P | Cabling

## Data sheet

Page 3/7

**M12 Sensor/actuator cable, A-coded, 5.0 m,  
M12 jack straight - M12 jack straight,  
unshielded, 5-pole, PUR**

P/N  
142MDA22050  
EAN 4251394648279  
2022/03/14  
Version: E

## Technical Data

### Connections/interfaces

Cable sheath diameter (min. - max.)

Cable sheath diameter	5.2 mm
Cable sheath diameter	0.205 in.

### Electrical characteristics

Current carrying capacity	4 A at 40 °C
Rated voltage	60 V
Insulation resistance	min. 100 MOhm

### Mechanical data

Life - Number of mating cycles	min. 100
Torsion	+/-180°/m, < 1 million cycles
Maximum operating bending radius	52 mm
Alternating bending radius	52 mm
acceleration	5 m/s <sup>2</sup>

### Materials and material properties

Material - Conductor	Cu (copper)
Material - Conductor Insulation	polypropylene
Material - Cable jacket	PUR
Material - Body interface 1	Plastics
Material - Body interface 2	Plastics
Material - Protective housing interface 1	FPM/FKM
Material - Protective housing interface 2	FPM/FKM
Material - Contact interface 1	CuSn (tin bronze)
Material - Contact interface 2	CuSn (tin bronze)
Material - Contact finish interface 1	Au (gold)
Material - Contact finish interface 2	Au (gold)
Material - Contact carriers interface 1	Plastics
Material - Contact carriers interface 2	Plastics
Material - Union nut interface 1	CuZnPb (brass)
Material - Union nut interface 2	CuZnPb (brass)
Material - Union nut finish interface 1	Ni (nickel)
Material - Union nut finish interface 2	Ni (nickel)

# P | Cabling

Data sheet

Page 4/7

**M12 Sensor/actuator cable, A-coded, 5.0 m,  
M12 jack straight - M12 jack straight,  
unshielded, 5-pole, PUR**

P/N  
142MDA22050  
EAN 4251394648279  
2022/03/14  
Version: E

## Technical Data

### Materials and material properties

Flame retardancy	yes
Halogen free	yes
Silicone free	no paint wetting interfering substances (LaBS) in the process chain
LaBS Note	subsequent contamination possible due to handling and possible storage in your company
Oil resistance	yes
UV-resistance	yes
drag chain suitable	yes
torsional	yes
RoHS	compliant
REACH	compliant
REACH - substance (SVHC)	Lead / 7439-92-1

### Environmental conditions

Temperature (min. - max.)	
Temperature - Operating °C	-50 °C - 90 °C
Temperature - Operating °F	-58 °F - 194 °F
Temperature - Installation °C	-30 °C - 90 °C
Temperature - Installation °F	-22 °F - 194 °F
Temperature - drag chain °C	-25 °C - 60 °C
Temperature - drag chain °F	-13 °F - 140 °F
Particulate ingress interface 1	IP6X when plugged in
Liquid ingress/immersion interface 1	IPX5, IPX7, IPX8 when plugged in
Particulate ingress interface 2	IP6X when plugged in
Liquid ingress/immersion interface 2	IPX5, IPX7, IPX8 when plugged in
Pollution degree interface 1	3
Pollution degree interface 2	3

# P | Cabling

Data sheet

Page 5/7

**M12 Sensor/actuator cable, A-coded, 5.0 m,  
M12 jack straight - M12 jack straight,  
unshielded, 5-pole, PUR**

P/N  
142MDA22050  
EAN 4251394648279  
2022/03/14  
Version: E

## Technical Data

Approvals	
CE	compliant
UL listed (file no.)	Approval pending
Standards/Regulations	
Connectors for electronic equipment	
circular connector	DIN EN 61076-2-101
Classifications	
ETIM 5.0	EC001855
ETIM 6.0	EC001855
ETIM 7.0	EC001855
ETIM 8.0	EC001855
Packing details	
Type of packaging	1 pc(s) / plastic bag

© 2022 METZ CONNECT - Technische Änderungen vorbehalten! Subject to modifications! Sous réserve de modifications techniques!

# P | Cabling

Data sheet

Page 6/7

**M12 Sensor/actuator cable, A-coded, 5.0 m,  
M12 jack straight - M12 jack straight,  
unshielded, 5-pole, PUR**

P/N  
142MDA22050  
EAN 4251394648279  
2022/03/14  
Version: E

## Illustrations

Dimensional drawing

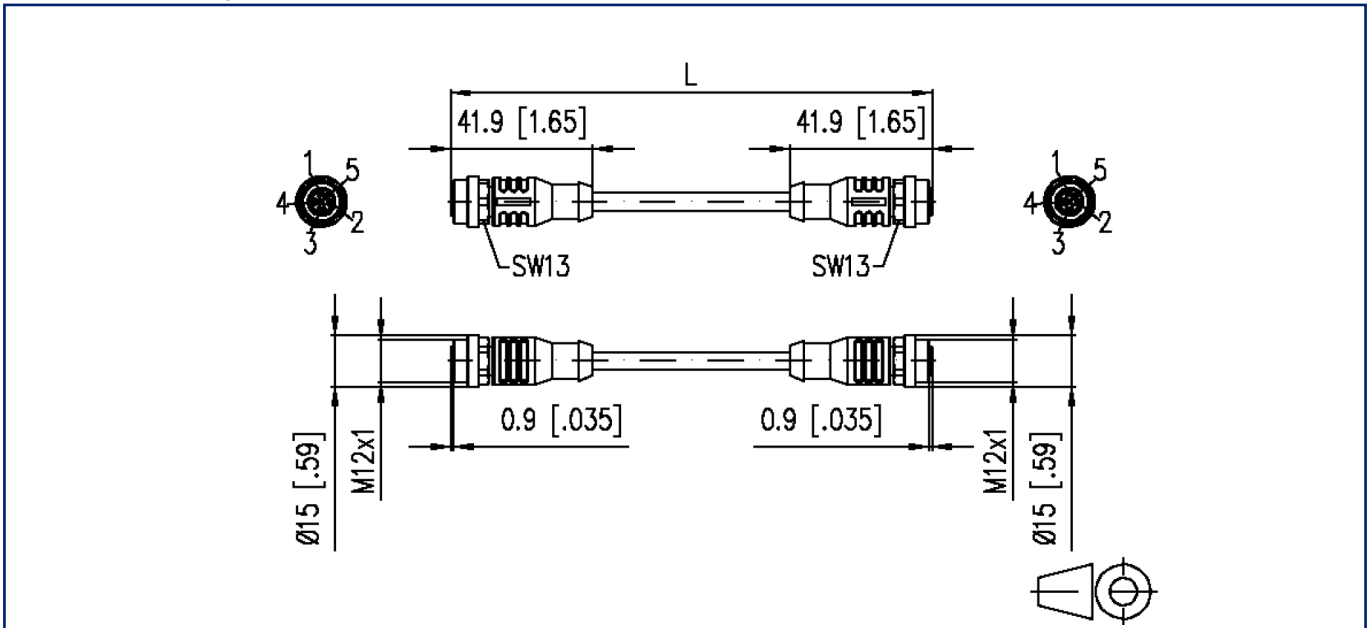

Wiring diagram

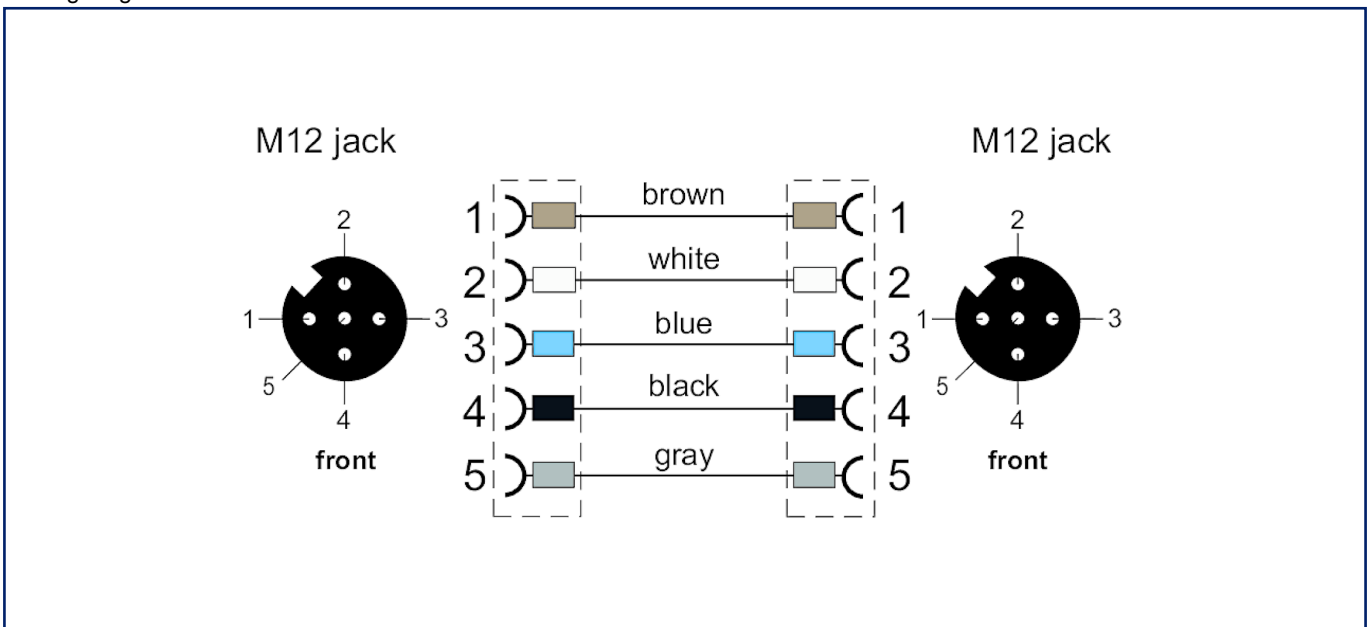

© 2022 METZ CONNECT - Technische Änderungen vorbehalten! Subject to modifications! Sous réserve de modifications techniques!

# P | Cabling

Data sheet

**M12 Sensor/actuator cable, A-coded, 5.0 m,  
M12 jack straight - M12 jack straight,  
unshielded, 5-pole, PUR**

Page 7/7

P/N

142MDA22050

EAN 4251394648279

2022/03/14

Version: E

## Illustrations

Principle diagram

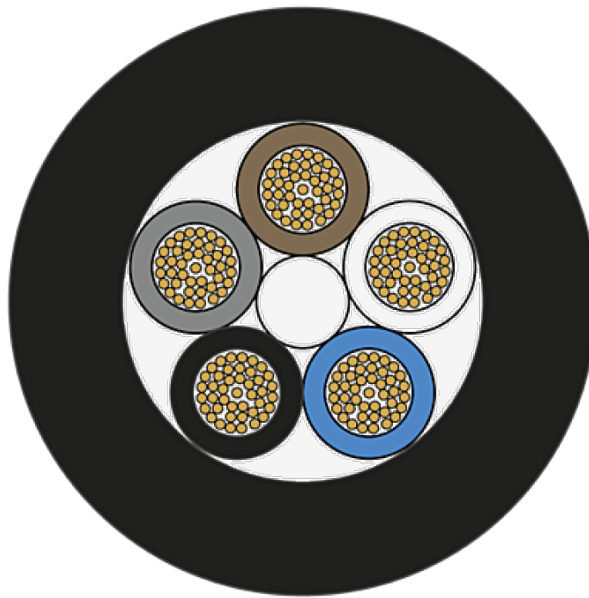

© 2022 METZ CONNECT - Technische Änderungen vorbehalten! Subject to modifications! Sous réserve de modifications techniques!

