

QUINT-PS-100-240AC/24DC/40

Power supply unit

INTERFACE

Data sheet
102315_en_02



© PHOENIX CONTACT 2010-04-23

1 Description

QUINT POWER power supply units for plant and special engineering reliably start heavy loads with high inrush currents using the POWER BOOST. Thanks to the wide-range input and extensive package of approvals, they can be used in all sectors of industry the world over. The switching output or floating relay contact are used for remote diagnostics.

Features

- Universal power supply unit with an extensive product range, including special versions and accessories
- Can be used worldwide in all industrial sectors due to a wide-range input and an international approval package
- High level of operational reliability thanks to high MTBF > 500,000 h, long mains buffering times > 20 ms
- Reliable starting of heavy loads with high inrush currents through the POWER BOOST power reserve
- Active function monitoring through switching output and preventive function monitoring through floating relay contact for remote diagnosis
- Parallel connection possible for increased performance and redundancy



DANGER OF EXPLOSION!

Only remove equipment when it is disconnected and not in the potentially explosive area.



DANGER

Components with dangerously high voltage and high stored energy are located in the device!
Never carry out work on live parts!
Depending on the ambient temperature and the load, the housing can become very hot!



Make sure you always use the latest documentation.
It can be downloaded from the product at www.phoenixcontact.net/catalog.

2 Table of contents

1	Description	1
	Features.....	1
2	Table of contents.....	2
3	Ordering data	3
4	Technical data	3
5	Structure.....	6
6	Block diagram	7
7	Safety and warning notes	7
8	Installation	8
9	Installation position.....	8
10	Mounting on DIN rails	9
	Low-profile installation	9
	Mounting position rotated 90°	9
11	Connection, network forms 100...240 V AC networks	10
12	Input	11
	Protection of the primary side.....	11
	Permissible backup fuse for mains protection	11
13	Output	11
	Protection of the secondary side.....	11
14	Signaling	12
	Floating contact.....	12
	Active signal output.....	12
	Signal loop.....	13
15	Function	13
	Output characteristic curve	13
	Thermal behavior	14
	Parallel operation	14
	Redundant operation	14
	Increased performance	15

3 Ordering data

Description	Type	Order No.	Pcs. / Pkt.
DIN rail power supply unit 24 V DC/40 A, primary switched-mode, 1-phase.	QUINT-PS-100-240AC/24DC/40	2938879	1
Accessories	Type	Order No.	Pcs. / Pkt.
Universal wall adapter	UWA 182/52	2938235	1

4 Technical data

Input data	
Input nominal voltage range	110 V AC ... 240 V AC
AC input voltage range	85 V AC ... 264 V AC (Derating < 100 V DC: 2.5%/V)
DC input voltage range	90 V DC ... 350 V DC (Derating < 110 V DC: 2.5%/V)
AC frequency range	45 Hz ... 65 Hz
DC frequency range	0 Hz
Current consumption	Approx. 12.5 A (120 V AC) Approx. 4.5 A (230 V AC)
Inrush current limitation	< 15 A (typical)
I^2t	< 3.2 A ² s
Power failure bypass	> 20 ms (120 V AC) > 20 ms (230 V AC)
Typical response time	< 1 s
Protective circuitry	Transient surge protection Varistor
Input fuse, integrated	20 A (fast blow, internal)
Recommended backup fuse for mains protection	16 A (characteristic B) 20 A (characteristic B)
Output data	
Nominal output voltage	24 V DC ±1%
Setting range of the output voltage	22.5 V DC ... 29.5 V DC (> 24 V constant capacity)
Output current	40 A (-25 °C ... 60 °C) 45 A (with POWER BOOST, -25 °C ... 40 °C permanent)
Derating	From +60 °C to 70 °C: 2.5% per Kelvin
Current limitation	Approx. $I_{BOOST} = 45$ A (for short circuit)
Max. capacitive load	Unlimited
Control deviation	< 1 % (change in load, static 10% ... 90%) < 2 % (change in load, dynamic 10% ... 90%) < 0.1 % (change in input voltage ±10%)
Efficiency	> 92 % (for 230 V AC and nominal values)
Ascent time	< 2 ms (U_{OUT} (10% ... 90%))
Residual ripple	< 30 mV _{PP} (with nominal values)
Peak switching voltages	< 50 mV _{PP} (20 MHz)
Connection in parallel	Yes, for redundancy and increased capacity
Connection in series	Yes
Surge protection against internal surge voltages	Yes, limited to approx. 35 V DC
Resistance to reverse feed	35 V DC
Power consumption	
Maximum power dissipation idling	28 W
Power loss nominal load max.	80 W

DC OK active

Output description	$U_{OUT} > 0.9 \times U_N$: High signal
Voltage	≤ 24 V
Current	≤ 20 mA (short circuit resistant)
Status display	"DC OK" LED green / $U_{OUT} < 0.9 \times U_N$: LED flashing

DC OK floating

Output description	Relay contact, $U_{OUT} > 0.9 \times U_N$: Contact closed
Voltage	≤ 30 V AC/DC
Current	≤ 1 A
Status display	"DC OK" LED green /

General data

Insulation voltage input/output	3 kV AC (type test) 2 kV AC (routine test)
Insulation voltage input / PE	3 kV AC (type test) 1.5 kV AC (routine test)
Insulation voltage output / PE	500 V DC (routine test)
Degree of protection	IP20
Class of protection	I, with PE connection
MTBF	> 500 000 h in acc. with IEC 61709 (SN 29500)
Type of housing	AluNox (AlMg1)
Dimensions W / H / D (state of delivery)	240 mm / 130 mm / 125 mm
Dimensions W / H / D (90° turned)	122 mm / 130 mm / 243 mm
Weight	3.5 kg

Ambient conditions

Ambient temperature (operation)	-25 °C ... 70 °C (> 60 °C derating)
Ambient temperature (storage/transport)	-40 °C ... 85 °C
Max. permissible relative humidity (operation)	95 % (at 25 °C, no condensation)
Vibration (operation)	< 15 Hz, amplitude ± 2.5 mm in acc. with IEC 60068-2-6 15 Hz ... 150 Hz, 2.3g, 90 min.
Shock	30g in all directions in acc. with IEC 60068-2-27
Pollution degree in acc. with EN 50178	2
Climatic class	3K3 (in acc. with EN 60721)

Standards

Electrical Equipment for Machinery	EN 60204 / Surge voltage category III
Safety transformers for power supply units	EN 61558-2-17
Electrical safety (of information technology equipment)	EN 60950/VDE 0805 (SELV) EN 61558-2-17
Electronic equipment for use in electrical power installations	EN 50178/VDE 0160 (PELV)
SELV	EN 60950 (SELV) EN 60204 (PELV)
Safe isolation	DIN VDE 0100-410 DIN VDE 0106-1010
Protection against electric shock	DIN 57100-410
Protection against electric shock, basic requirements for safe isolation in electrical equipment	DIN VDE 0106-101
Limitation of mains harmonic currents	EN 61000-3-2
Device safety	GS (tested safety)
Certificate	CB Scheme

Approvals

UL approvals	UL/C-UL listed UL 508 UL/C-UL Recognized UL 60950 UL/C-UL Listed UL 1604 Class I, Division 2, Groups A, B, C, D
Shipbuilding	Germanischer Lloyd (EMC 2), ABS, DNV



Current approvals can be found for the product in the download area.

Conformance with EMC guideline 2004/108/EC and for low-voltage guideline 2006/95/EC

Noise immunity according to EN 61000-6-2

Electrostatic discharge	EN 61000-4-2
	Housing Level 4
	Contact discharge 8 kV
	Discharge in air 15 kV
	Comments Criterion B
Electromagnetic HF field	EN 61000-4-3
	Housing Level 3
	Frequency range 80 MHz ... 1 GHz
	Field intensity 10 V/m
	Frequency range 1.4 GHz ... 2 GHz
	Field intensity 10 V/m
	Comments Criterion A
Fast transients (burst)	EN 61000-4-4
	Input 4 kV (level 4 - asymmetrical)
	Output 2 kV (Level 3 - asymmetrical)
	Signal 1 kV (Level 2 - asymmetrical)
	Comments
Surge current loads (surge)	EN 61000-4-5
	Input 4 kV (inst. class 4 - asymmetrical: conductor to ground) 2 kV (Inst. Class 4 - symmetrical: Conductor to ground)
	Output 0.5 kV (level 1 - asymmetrical: conductor to ground) 0.5 kV (Level 1 - symmetrical: Conductor to ground)
	Signal 1 kV (level 2 - asymmetrical: conductor to ground)
	Comments Criterion B
Conducted interference	EN 61000-4-6
	Input/Output/Signal Level 3 - asymmetrical
	Frequency range 0.15 MHz ... 80 MHz
	Voltage 10 V
	Comments Criterion A
Voltage dips	EN 61000-4-11
	Input (mains buffering > 20 ms)
	Comments Criterion B

Emitted interference in acc. with EN 61000-6-3

Radio interference voltage in acc. with EN 55011	EN 55011 (EN 55022) Class B, area of application: Industry and residential
Emitted radio interference in acc. with EN 55011	EN 55011 (EN 55022) Class B, area of application: Industry and residential

5 Structure

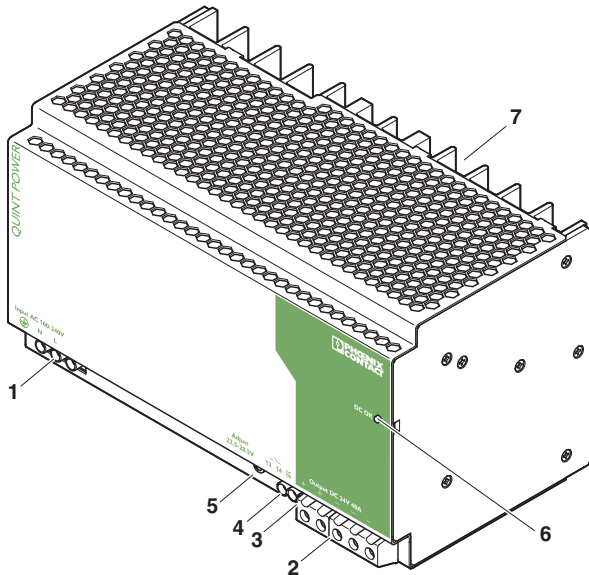

- 1 AC input
- 2 DC output
- 3 DC OK output active
- 4 DC OK output, floating
- 5 Potentiometer (covered) 22.5 ... 29.5 V DC
- 6 "DC OK" LED, green
- 7 DIN rail adapter

	[mm ²]		AWG	[Nm] Torque
	solid	stranded		
Input	0.2 - 6	0.2 - 4	24 - 10	0.5 - 0.6
Output	0.5 - 16	0.5 - 10	20 - 6	0.5 - 0.6
Signal	0.2 - 6	0.2 - 4	24 - 10	0.5 - 0.6

Input data

Input nominal voltage range	110 V AC ... 240 V AC
AC input voltage range	85 V AC ... 264 V AC (Derating < 100 V DC: 2.5%/V)
DC input voltage range	90 V DC ... 350 V DC (Derating < 110 V DC: 2.5%/V)
AC frequency range	45 Hz ... 65 Hz
DC frequency range	0 Hz
Input fuse, integrated	20 A (fast blow, internal)
Recommended backup fuse for mains protection	16 A (characteristic B) 20 A (characteristic B)
Type of connection	Screw connection
Stripping length	7 mm

Output data

Nominal output voltage	24 V DC \pm 1%
Setting range of the output voltage	22.5 V DC ... 29.5 V DC (> 24 V constant capacity)
Output current	40 A (-25 °C ... 60 °C) 45 A (with POWER BOOST, -25°C ... 40°C permanent)
Type of connection	Screw connection
Stripping length	10 mm

6 Block diagram

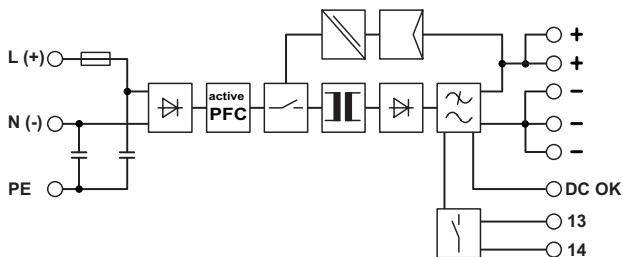

7 Safety and warning notes



DANGER OF EXPLOSION!

Only remove equipment when it is disconnected and not in the potentially explosive area.

DANGER

The device contains dangerous live elements and high levels of stored energy.
Never carry out work when the power is turned on.



Before startup please ensure:

The mains connection has been carried out by a competent person and protection against electric shock is guaranteed!

The device can be disconnected outside the power supply unit in accordance with the regulations as in EN 60950 (e.g. through primary side line protection)!

The ground conductor is connected!

All feed lines are sufficiently protected and dimensioned!

All output lines are dimensioned according to the maximum output current of the device or separately protected!

Sufficient convection must be guaranteed.



CAUTION

The power supply units are built-in devices. The device may only be installed and put into operation by qualified personnel. The corresponding national regulations must be observed.

8 Installation

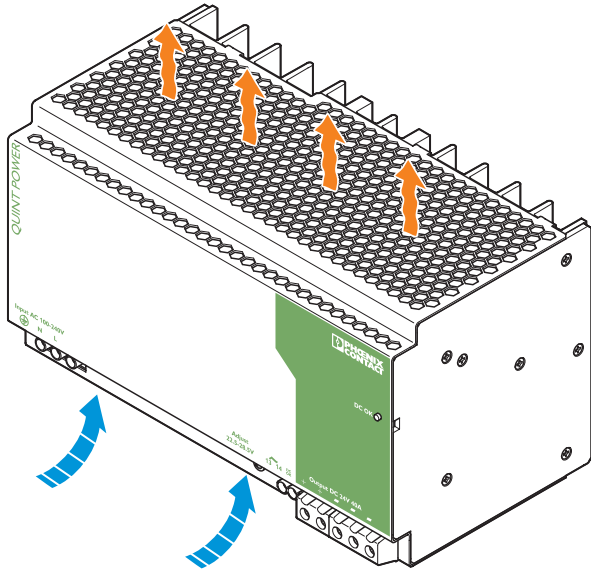

Note:

To ensure sufficient convection, we recommend the following minimum spacing be used between modules: 5 cm for vertical installation and 0 cm for horizontal installation.



The power supply unit can be snapped onto all DIN rails in acc. with EN 60715. They must be mounted horizontally (connecting terminal blocks bottom).

9 Installation position

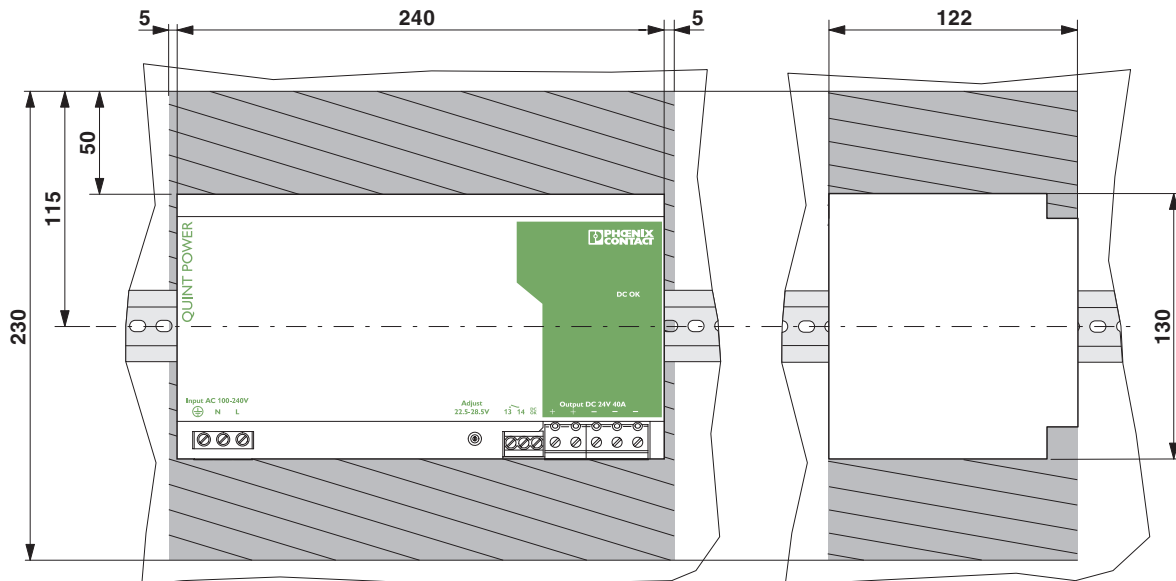

Low-profile installation: Installation depth 125 mm (+ DIN rail)

Mounting position rotated 90°: Installation depth 243 mm (+ DIN rail)

10 Mounting on DIN rails

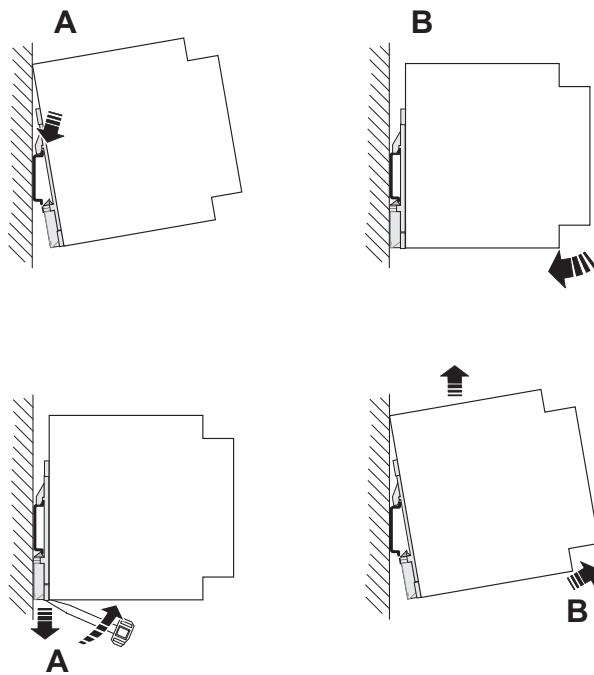

Low-profile installation

Assembly:

Position the module with the DIN rail guide on the upper edge of the DIN rail, and snap it in with a downward motion.

Removing:

Pull the snap lever open with the aid of a screwdriver and slide the module out at the lower edge of the DIN rail.

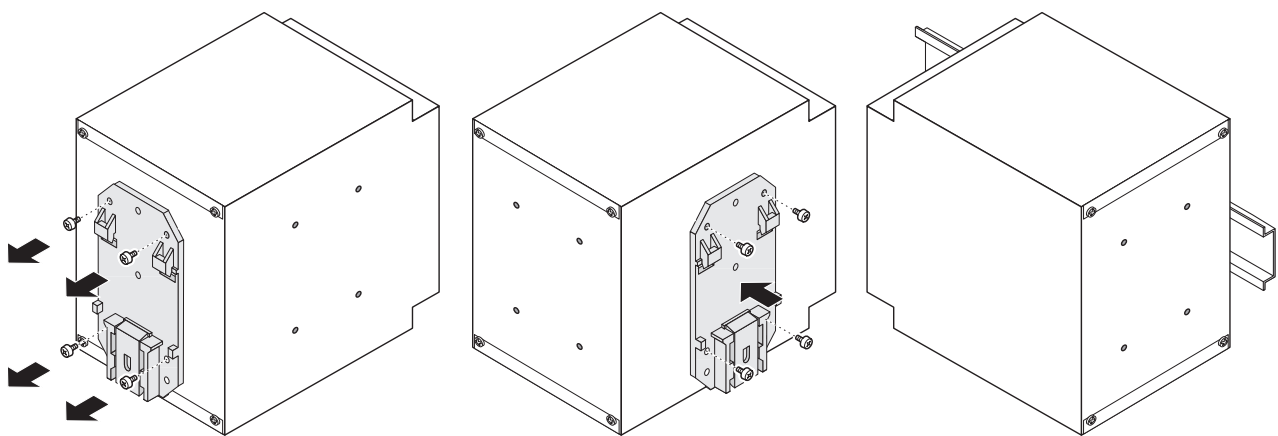

Mounting position rotated 90°

For a mounting position rotated at 90° to the DIN rail, mount the DIN rail adapter (UTA 107) as shown in the figure. No additional assembly material is required. Mounting screws: Torx T10 (0.8 Nm ... 0.9 Nm tightening torque).

11 Connection, network forms 100...240 V AC networks

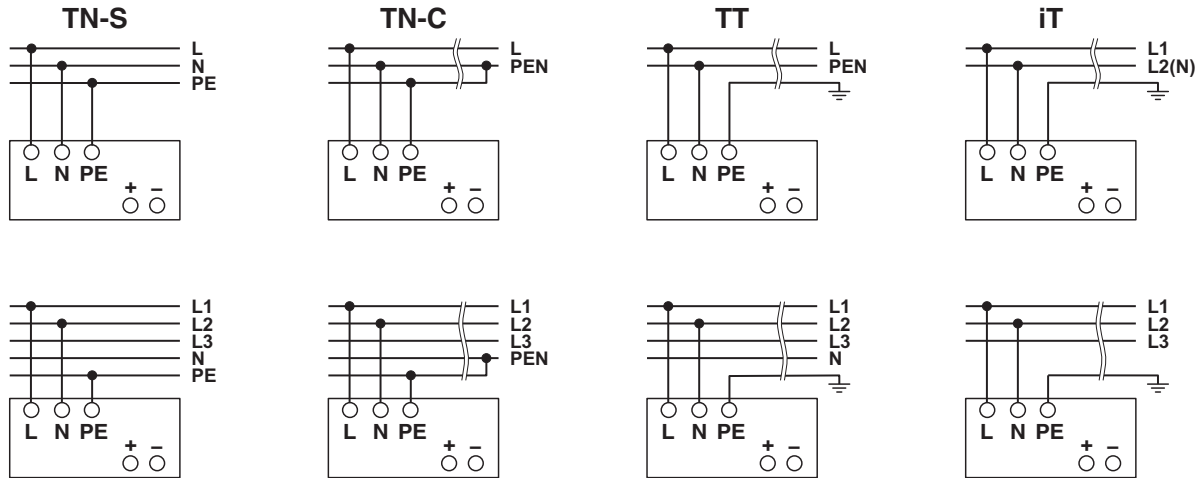

The connection for 100 V AC ... 240 V AC is established using the L, N, and P screw connections.

The device can be connected to 1-phase AC networks or to two of the phase conductors of three-phase systems (TN, TT or IT systems) in accordance with VDE 0100-300/IEC 60364-3) with nominal voltages of 100 V AC ... 240 V AC.

The device also continues to work on short-term input voltages > 300 V AC.



ATTENTION

Suggestion: In AC connections, connect a maximum of one power supply unit to a fuse or a power switch.

In order to comply with UL approval, use copper cables with an operating temperature of > 75°C (ambient temperature < 55°C) and > 90°C (ambient temperature < 75°C).

To meet EN 60950/UL 60950, flexible cables must be fitted with ferrules. To meet GL requirements, unused terminal compartments should be closed. For reliable and safe-to-touch connections, strip the cable ends according to the table in the "Structure" section.

12 Input

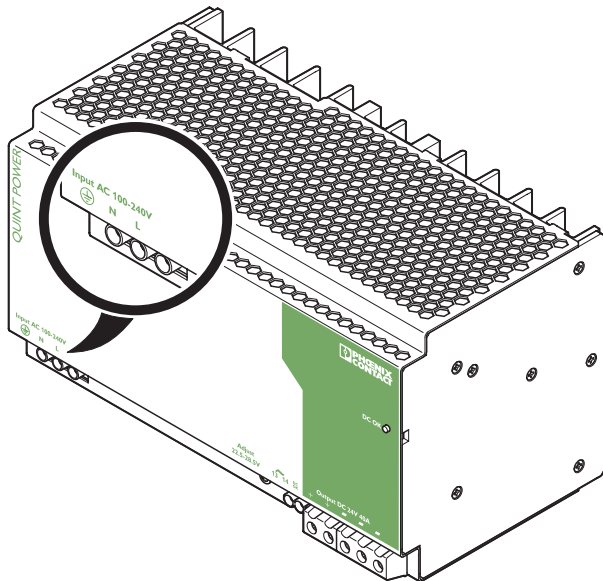

CAUTION

If an internal fuse is triggered, there is a device malfunction. In this case, the device must be inspected in the factory.

Protection of the primary side

The device must be installed in acc. with the regulations as in EN 60950. It must be possible to disconnect the device using a suitable isolating facility outside the power supply. The primary side line protection, for example, is suitable. For device protection, there is an internal fuse. Additional device protection is not necessary.

Permissible backup fuse for mains protection

Power circuit-breaker 16 A or 25 A, characteristic B (or identical function). In DC applications, a suitable backup fuse must be wired in!

13 Output

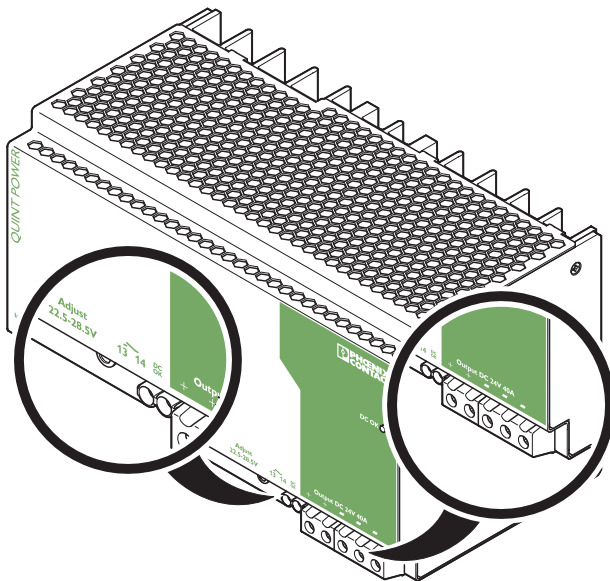

ATTENTION

Make sure that all output lines are dimensioned according to the maximum output current or are separately protected. The cables on the secondary side must have sufficiently large cross sections in order to keep the voltage drops on the lines as low as possible.

The connection is established via the screw connections on the screw connection of the DC output:
 24 V DC: "+" and "-"; DC OK switching output active: "DC OK" and "-"; DC OK output floating: "13" and "14".
 The output voltage set upon delivery is 24 V DC. The output voltage can be set on the potentiometer.

Protection of the secondary side

The device is electronically protected against short-circuit and idling. In the event of a malfunction, the output voltage is limited to 35 V DC. Make sure that all output lines are dimensioned according to the maximum output current or are separately protected! The cables on the secondary side should have large cross sections in order to keep the voltage drops on the lines as low as possible.

14 Signaling

The active DC OK signal output and the floating DC OK signal contact are provided to monitor the function. In addition, the DC OK LED can be used to evaluate the function of the power supply directly at the installation location (see output characteristic curve).

	$I < I_N$	$U_{OUT} < 0.9 \times U_N$
"DC OK" LED	ON	Flashing
Active DC OK switching output	ON	OFF
Floating DC OK output	Closed	Open
Meaning	Normal operation of the power supply unit ($U_{OUT} > 21.5 \text{ V}$)	Overload mode, e.g. consumer short circuit or overload

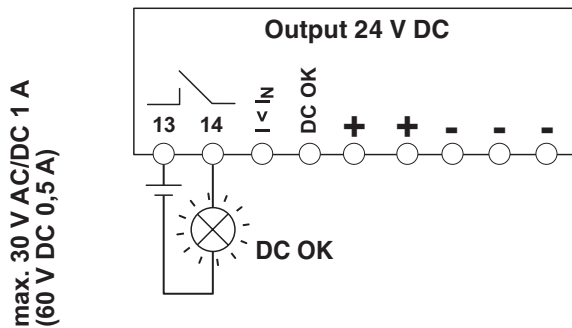

Floating contact

The floating signal contact opens and indicates that the set output voltage has been undershot by more than 10 %. Signals and ohmic loads up to a maximum of 30 V AC/DC and currents to a maximum of 1 A (or maximum of 60 V DC with a maximum of 0.5 A) can be switched. For heavily inductive loads such as a relay, a suitable protection circuit (e.g., damping diode) is necessary.

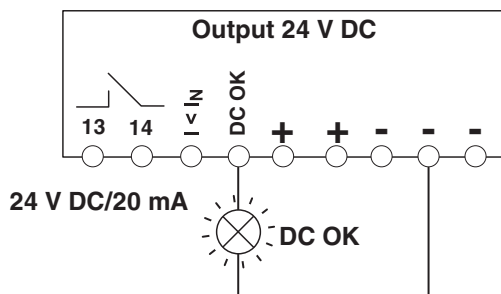

Active signal output

The 24 V DC signal is applied between the "DC OK" and "-" connecting terminal blocks and can carry up to 40 mA. This signal output signalizes when the output voltage is more than 10% below the output voltage by switching from "active high" to "low".

The DC OK signal is decoupled from the power output. It is thus not possible for parallel switched devices to provide external supply.

The 24 V DC signal can be directly connected to a logic input for evaluation.

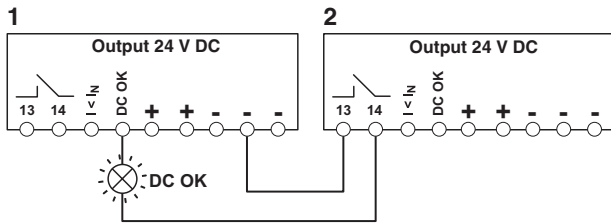

Signal loop

Monitoring two devices: Use the active signal output of device 1 and loop in the floating signal output of device 2. In the event of malfunctioning, a common alarm is output. Any number of devices can be looped in. This signal combination saves wiring costs and logic inputs.

15 Function

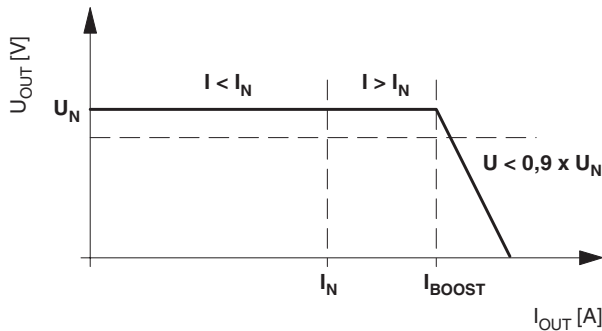

Output characteristic curve

The power supply works with the static POWER BOOST power reserve as shown in the U/I characteristic curve in the figure. At ambient temperatures $T_{amb} < +40\text{ °C}$, I_{BOOST} is available continuously. At higher temperatures, it is available for a few minutes. In the event of a secondary-side short circuit or overload, the output current is limited to I_{BOOST} . Thereby, the module does not switch off, but rather supplies a continuous output current. The secondary voltage is reduced here until the short circuit is eliminated. The U/I characteristic curve with the POWER BOOST power reserve ensures that both high inrush currents of capacitive loads as well as loads with DC/DC converters in the primary circuit can be supplied.

In order to trip standard circuit breakers magnetically and therefore quickly, power supply units have to provide a multiple of the nominal current for a short time.

The characteristic curve shows when $I < I_N$, $I > I_N$ and U is $< 0,9 \times U_N$. The "signaling" table is to be consulted for the respective signaling.

$$U_N = 24\text{ V}$$

$$I_N = 40\text{ A}$$

$$I_{BOOST} = 45\text{ A}$$

$$P_N = 960\text{ W}$$

$$P_{BOOST} = 1080\text{ W}$$

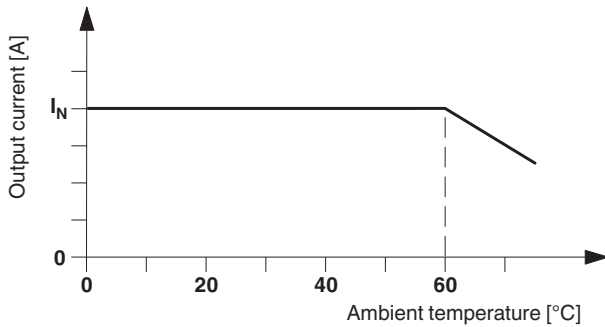

Thermal behavior

With an ambient temperature of up to +40°C, the device supplies the continuous output current of I_{BOOST} . The device can supply a nominal output current of I_N with ambient temperatures of up to +60°C. In the case of ambient temperatures above +60°C, the output current must be reduced by 2.5% per Kelvin increase in temperature. The device does not switch off at ambient temperatures of +70°C or thermal overload. The output capacity is reduced as far as necessary to provide device protection. After it has cooled down, the output capacity is increased again.

Parallel operation

Devices of the same type can be connected in parallel to increase both redundancy and power. By default upon delivery, no further adjustments are required. If the output voltage is adjusted, a uniform distribution of power is guaranteed by setting all parallel operated power supply units to exactly the same output voltage. To ensure symmetrical current distribution we recommend that all cable connections from the power supply unit to the busbar are the same length and have the same cross section. Depending on the system, for parallel connection of more than two power supplies a protective circuit should be installed at each individual device output (e.g., decoupling diode, DC fuse or circuit breaker). This prevents high return currents in the event of a secondary device fault.

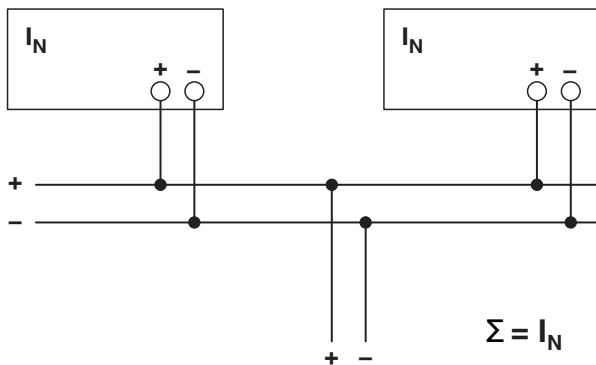

Redundant operation

Redundant circuits are suitable for the supply of systems which make especially high requirements on the operational safety. If a fault occurs in the primary circuit of the first power supply unit, the second device automatically takes over the entire power supply, without interruption, and vice versa. For this reason, the power supply units to be connected in parallel are dimensioned in such a way that the total current requirement of all consumers can be completely covered by one power supply unit. 100% redundancy makes external decoupling diodes necessary (QUINT-DIODE/40, Order No. 2938963)!

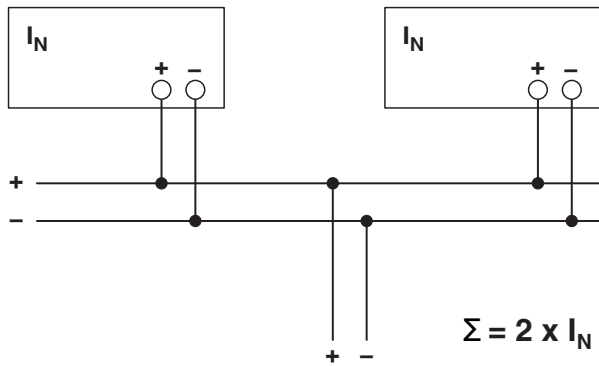

Increased performance

For n parallel connected devices, the output current can be increased to $n \times I_N$. Parallel connection for increasing power is used when extending existing systems. A parallel connection is recommended if the power supply unit does not cover the current consumption of the most powerful load. Otherwise, the load should be divided between individual devices that are independent from one another.