

SWITCH FUNCTION A1
CIRCUIT DIAGRAM

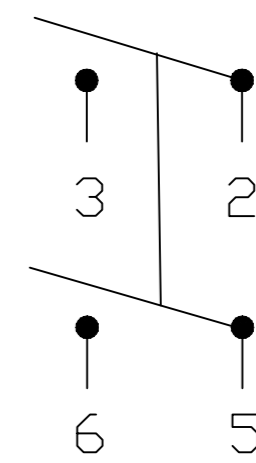

OBSOLETE 1571102-1
SHOWN

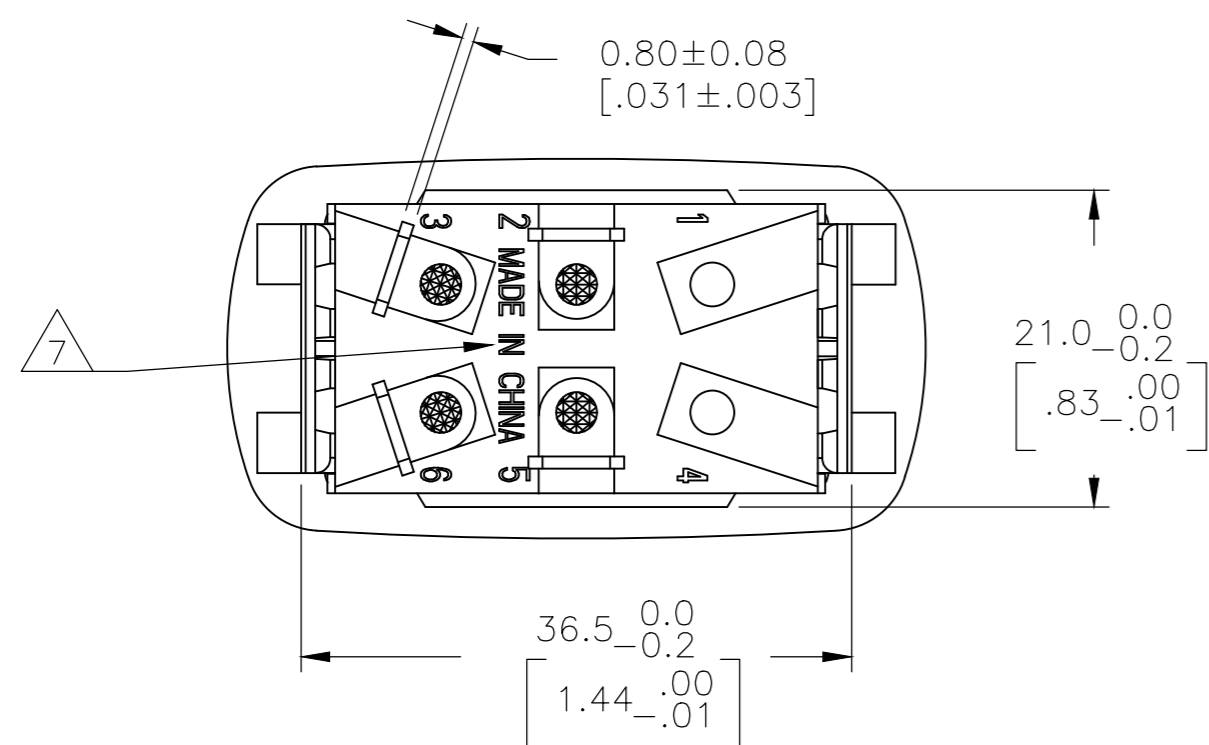

P	LTR	REVISION RECORD	DATE	DWN	APVD
E		REVISED PER ECO-18-017612	28NOV2018	RSM	PO
D1		REVISED PER ECO-16-017354	09MAR2017	RK	AS
D		REVISED PER ECO-14-016691	05NOV2014	NK	RH

DIMENSIONS: mm [INCHES]		TOLERANCES UNLESS OTHERWISE SPECIFIED:	
0 PLC	± -	0 PLC	± -
1 PLC	± -	1 PLC	± -
2 PLC	± -	2 PLC	± -
3 PLC	± -	3 PLC	± -
4 PLC	± -	4 PLC	± -
ANGLES ±		-	
SURFACE TEXTURE		√	

DWN	25FEB2002	MATERIAL	HEAT TREAT
M.BINNER		1 2	-
CHK	16NOV05		
D.ROHDE			
APVD	16NOV05	POWER ROCKER SWITCH, 21.2mm X 36.6mm MIN PANEL SIZE DPST, NON-ILLUMINATED	
D.ROHDE		SCALE	SIZE
NAME		2:1	A2
		DRAWING NO	SHEET
		1571102	1 OF 4
			REV
			E

D
C
B
A

THIS INFORMATION IS CONFIDENTIAL AND PROPRIETARY TO TYCO ELECTRONICS CORPORATION AND ITS WORLDWIDE SUBSIDIARIES AND AFFILIATES (TE). IT MAY NOT BE DISCLOSED TO ANYONE, OTHER THAN TE PERSONNEL, WITHOUT AUTHORIZATION FROM TE (www.TE.com).

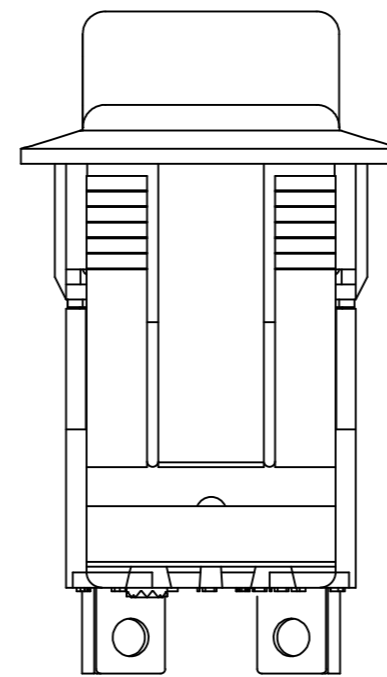
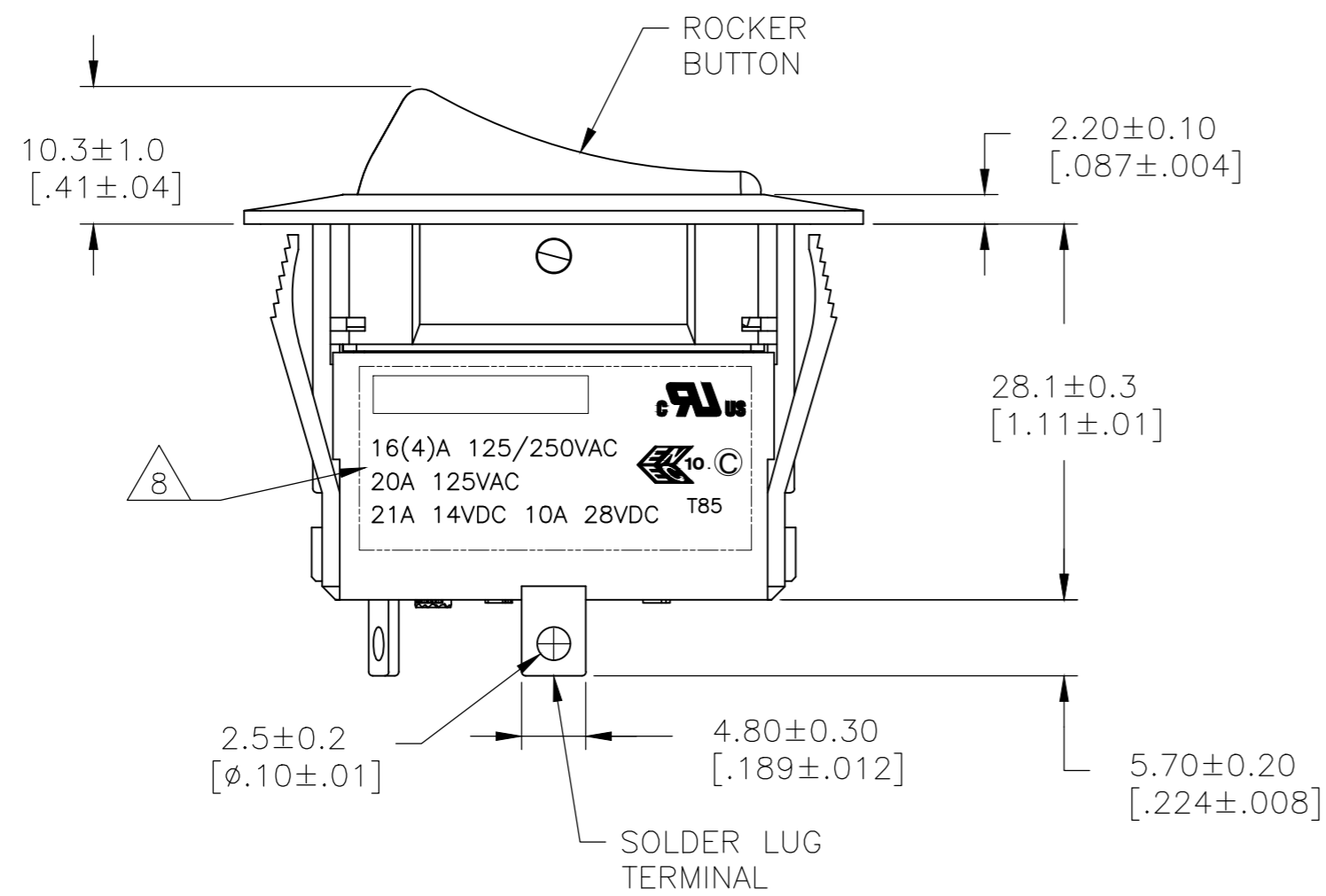
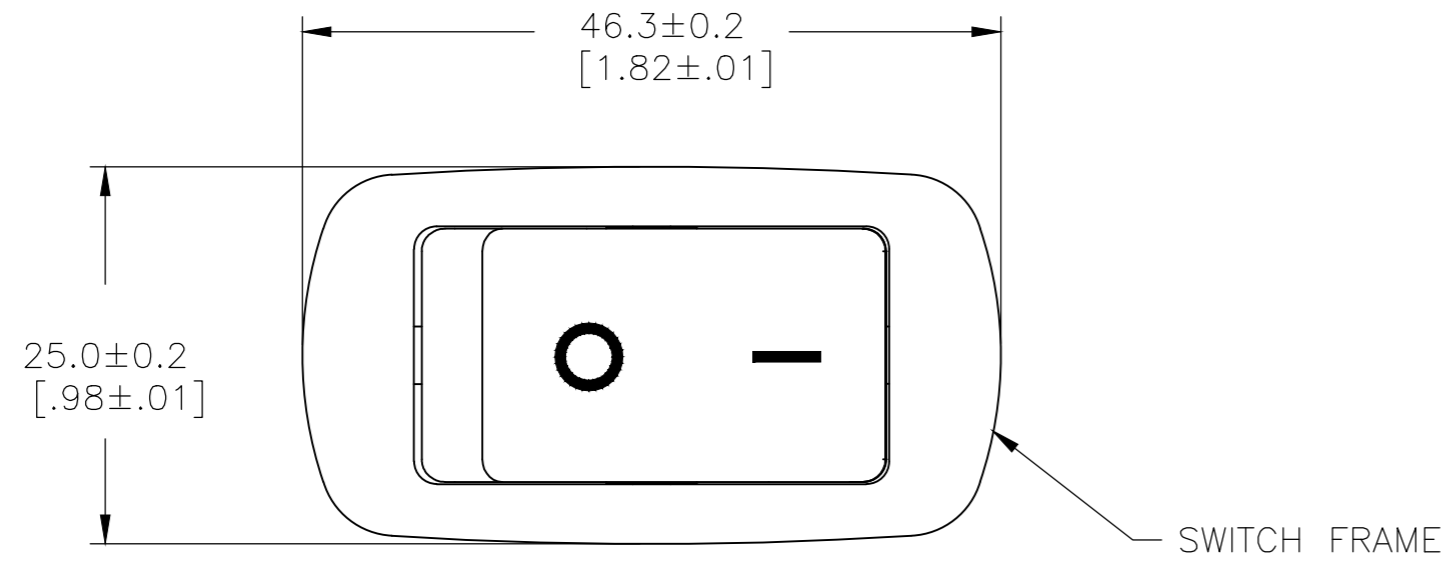

SWITCH FUNCTION A1
CIRCUIT DIAGRAM

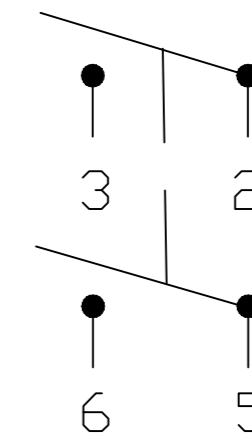

OBSOLETE 1571102-5
SHOWN

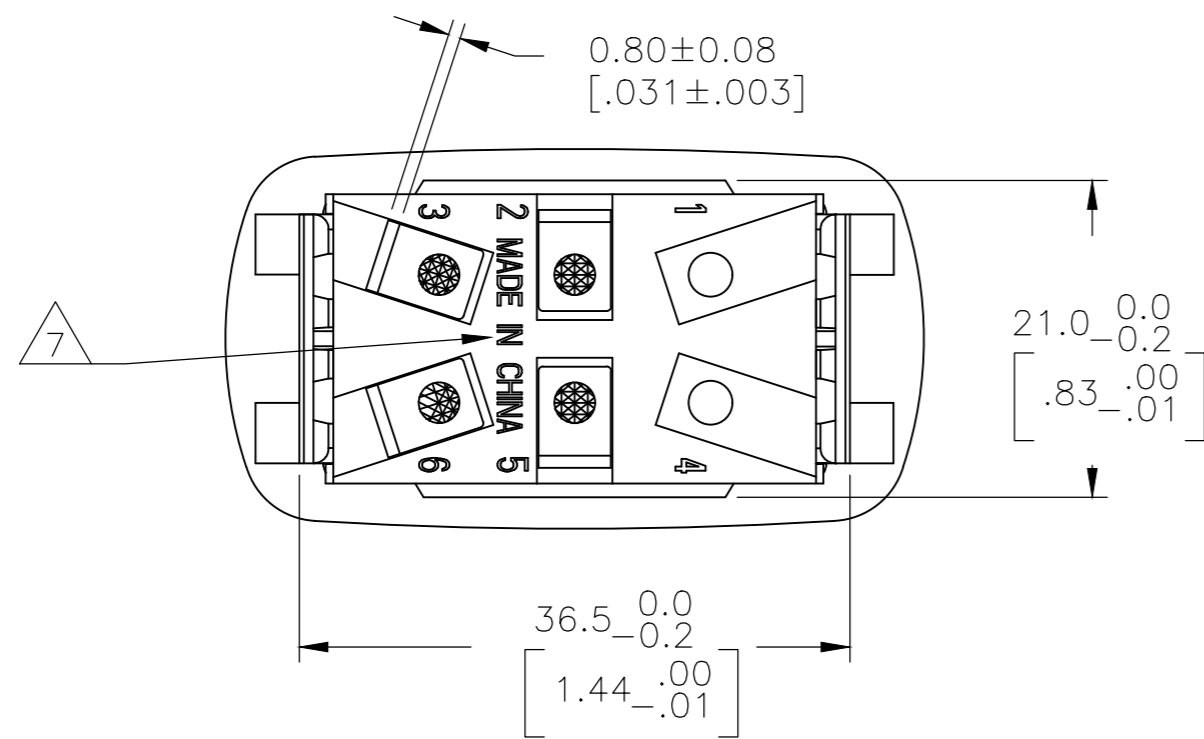

P	LTR	REVISION RECORD	DATE	DWN	APVD
-	-	SEE SHEET 1	-	-	-

DIMENSIONS: mm [INCHES]		TOLERANCES UNLESS OTHERWISE SPECIFIED:	
	0 PLC ± -	1 PLC ± -	2 PLC ± -
	3 PLC ± -	4 PLC ± -	
ANGLES ±		SURFACE TEXTURE	
-			

DWN M.BINNER	25FEB2002	MATERIAL 	HEAT TREAT -
CHK D.ROHDE	16NOV05		
APVD D.ROHDE	16NOV05		
NAME POWER ROCKER SWITCH, 21.2mm X 36.6mm MIN PANEL SIZE DPST, NON-ILLUMINATED			
SCALE 2:1	SIZE A2	DRAWING NO. 1571102	SHEET 2 OF 4
			REV E

THIS INFORMATION IS CONFIDENTIAL AND PROPRIETARY TO TYCO ELECTRONICS CORPORATION AND ITS WORLDWIDE SUBSIDIARIES AND AFFILIATES (TE). IT MAY NOT BE DISCLOSED TO ANYONE, OTHER THAN TE PERSONNEL, WITHOUT AUTHORIZATION FROM TE (www.TE.com).

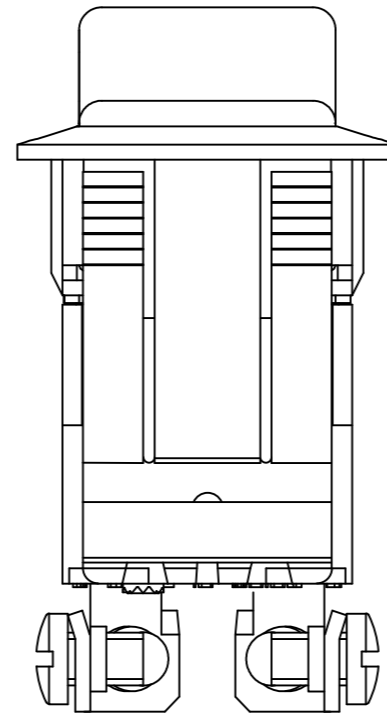
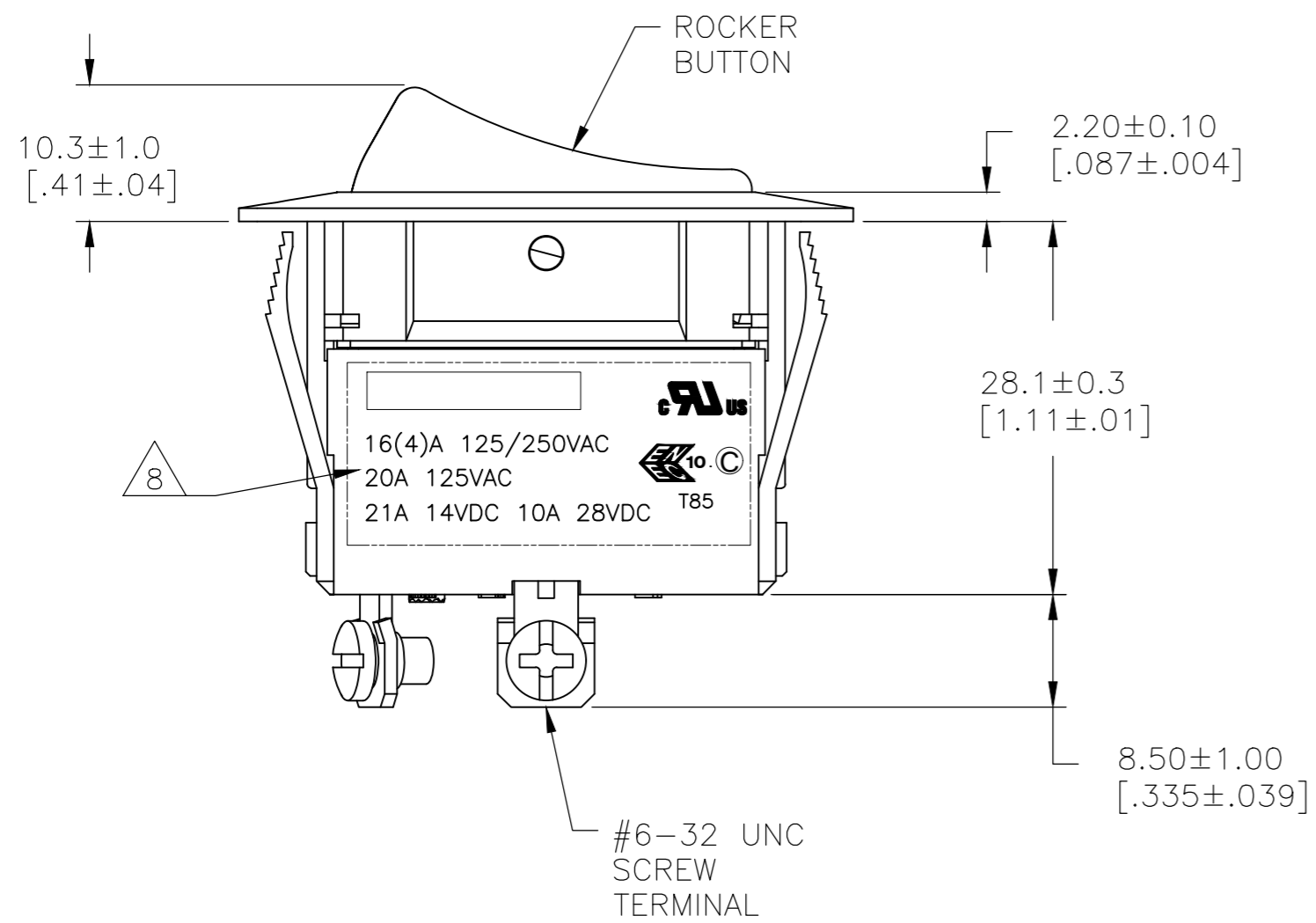
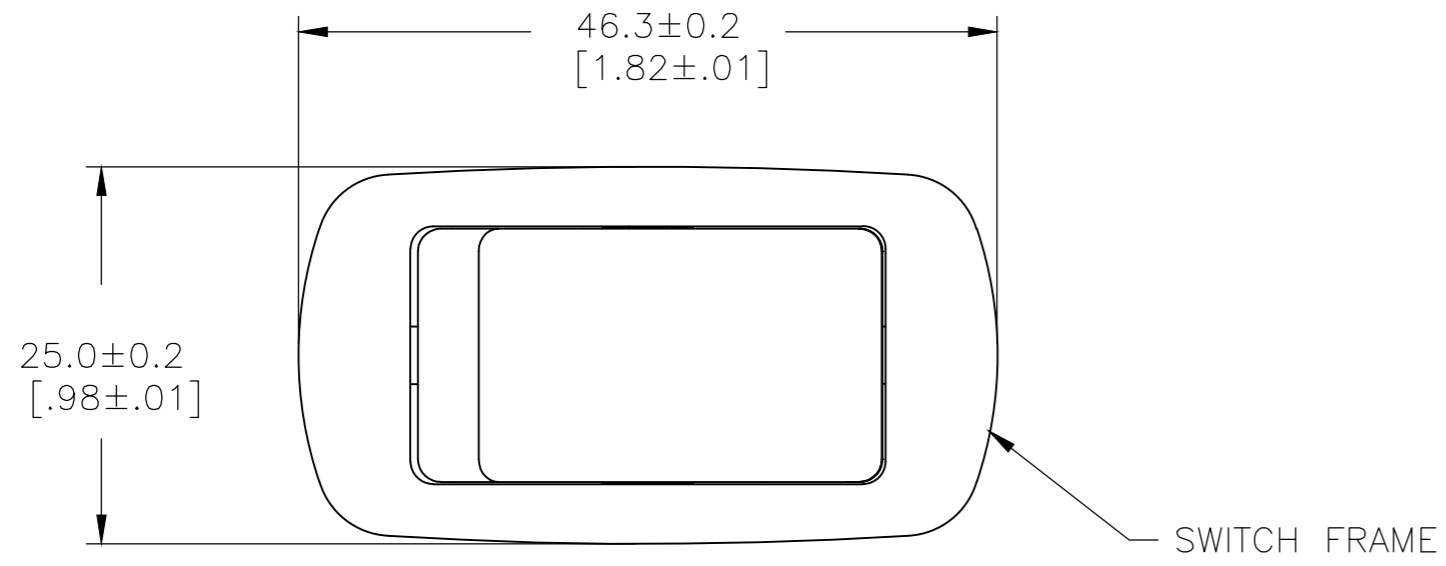

SWITCH FUNCTION A1
CIRCUIT DIAGRAM

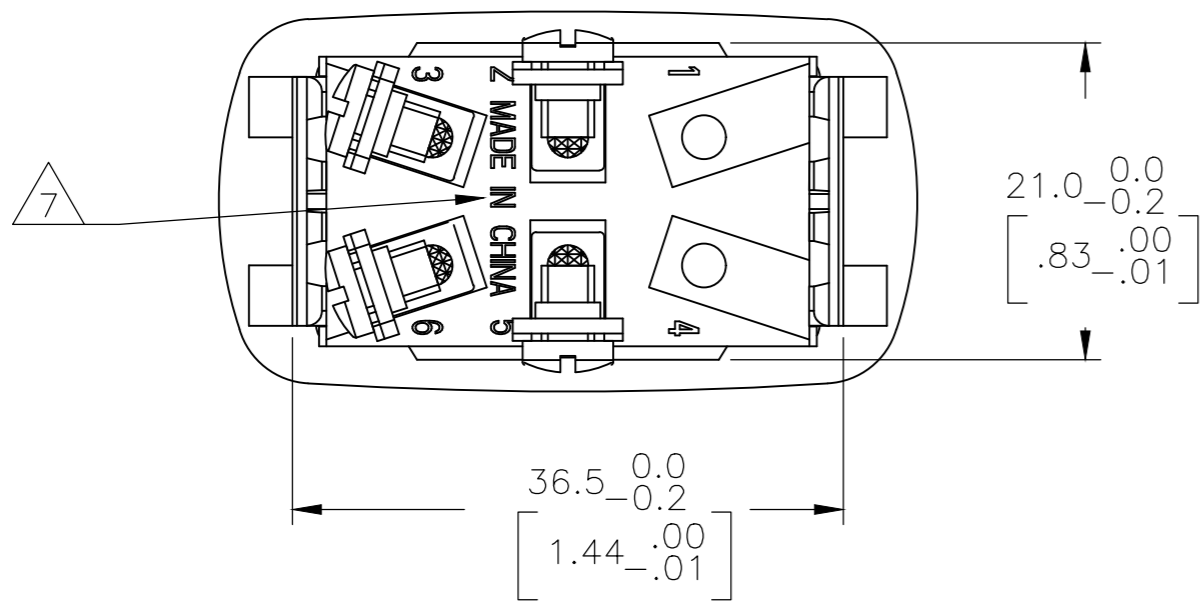
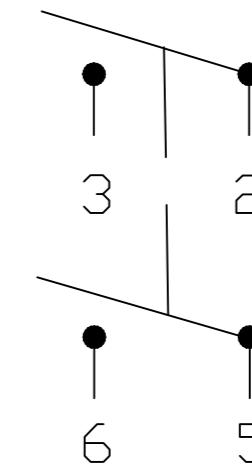

OBSOLETE 1571102-9
SHOWN

THIS INFORMATION IS CONFIDENTIAL AND PROPRIETARY TO TYCO ELECTRONICS CORPORATION AND ITS WORLDWIDE SUBSIDIARIES AND AFFILIATES (TE). IT MAY NOT BE DISCLOSED TO ANYONE, OTHER THAN TE PERSONNEL, WITHOUT AUTHORIZATION FROM TE (www.TE.com).

P	LTR	REVISION RECORD	DATE	DWN	APVD
-	-	SEE SHEET 1	-	-	-

DIMENSIONS: mm [INCHES]		TOLERANCES UNLESS OTHERWISE SPECIFIED:	
	0 PLC ± -	1 PLC ± -	2 PLC ± -
	3 PLC ± -	4 PLC ± -	
ANGLES ±		SURFACE TEXTURE	
-			

DWN M.BINNER	25FEB2002	MATERIAL 	HEAT TREAT -
CHK D.ROHDE	16NOV05	TE Connectivity	
APVD D.ROHDE	16NOV05		
NAME POWER ROCKER SWITCH, 21,2mm X 36,6mm MIN PANEL SIZE DPST, NON-ILLUMINATED			
SCALE 2:1	SIZE A2	DRAWING NO. 1571102	SHEET 3 OF 4
			REV E

