

High-side Gate Driver IC SSC4S790

Data Sheet

Description

SSC4S790 is a single channel high-side gate driver. The IC incorporates a floating drive circuit for a high-side power MOSFET, which can be used for a high-side gate driver such as a half-bridge converter or bridgeless PFC.

The IC is provided in the compact and low profile SOIC8 package.

Features

- Single Input and Output
- Breakdown Voltage of Floating Driver: 600 V
- 3.3 V Logic Signal Compatible
- CMOS Schmitt-trigger Input with Pull-down
- Output in Phase with Input
- Protections
 - High-side Driver Undervoltage Lockout (UVLO): Auto-restart
 - VCC Pin Overvoltage Protection (OVP): Latched shutdown
 - Thermal Shutdown (TSD): Latched shutdown

Package

SOIC8

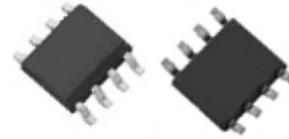

Not to scale

Specifications

- Power Supply Voltage, V_{CC} : 12 V to 18 V
- VGO Pin Peak Source Current: -300 mA
- VGO Pin Peak Sink Current: 550 mA

Applications

- White Goods
- Office Automation Equipment
- Audio Visual Equipment
- Industrial Equipment
- Other Switched Mode Power Supply (SMPS)

Typical Application

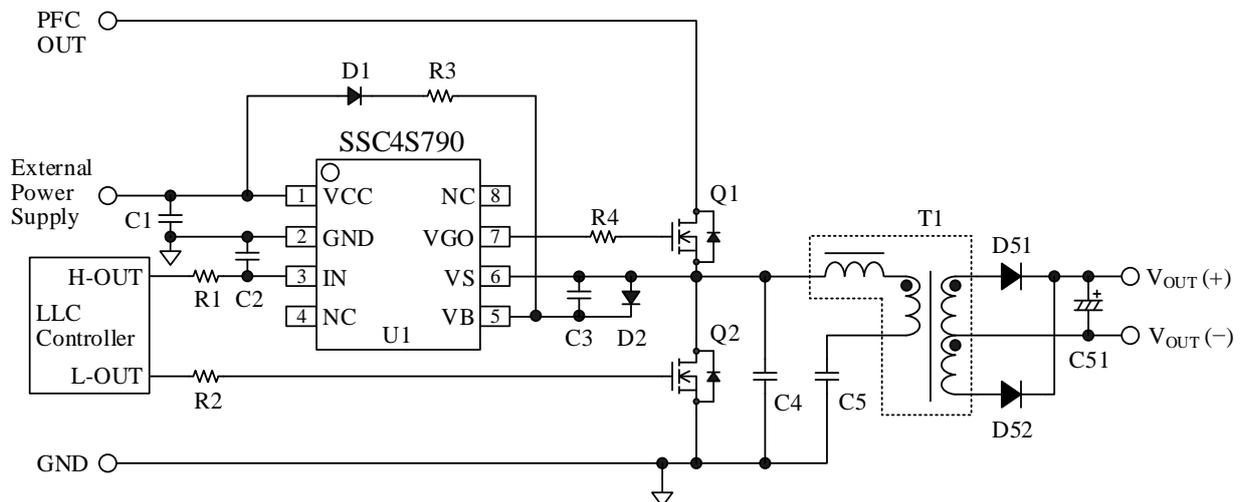

Contents

Description	1
Package	1
Contents	2
1. Absolute Maximum Ratings	3
2. Electrical Characteristics	4
3. Block Diagram	5
4. Pin Configuration Definitions	5
5. Typical Application	6
6. Physical Dimensions	7
7. Marking Diagram	8
8. Operational Description	9
8.1. Start / Stop Operation	9
8.2. Pin Descriptions	9
8.2.1. IN	9
8.2.2. VB and VS	9
8.2.3. VGO	10
8.3. High-side Driver Undervoltage Lockout	10
8.4. VCC Pin Overvoltage Protection (OVP)	10
8.5. Thermal Shutdown (TSD)	10
Important Notes	11

1. Absolute Maximum Ratings

Current polarities are defined as follows: current going into the IC (sinking) is positive current (+); current coming out of the IC (sourcing) is negative current (-). Unless otherwise specified, $T_A = 25\text{ }^\circ\text{C}$. Surge withstand capability (HBM) of the SSC4S790 is guaranteed up to 2000 V. Note that the following pins are guaranteed to withstand surges up to 1000 V: 5, 6, 7.

Parameter	Symbol	Conditions	Pins	Rating	Unit
VCC Pin Voltage	V_{CC}		1 – 2	-0.3 to 20	V
IN Pin Voltage	V_{IN}		3 – 2	-0.3 to 5	V
High-side Driver Control Voltage	V_{BS}	$V_B - V_S$	5 – 6	-0.3 to 20	V
VS Pin Voltage	V_S		6 – 2	-1 to 600	V
VGO Pin Voltage	V_{GO}		7 – 6	$V_S - 0.3$ to $V_B + 0.3$	V
Power Dissipation	P_D		—	0.69	W
Operating Ambient Temperature	T_{OP}		—	-40 to 85	$^\circ\text{C}$
Storage Temperature	T_{STG}		—	-40 to 125	$^\circ\text{C}$
Junction Temperature	T_J		—	150	$^\circ\text{C}$

2. Electrical Characteristics

Current polarities are defined as follows: current going into the IC (sinking) is positive current (+); current coming out of the IC (sourcing) is negative current (-).

Unless otherwise specified, $T_A = 25\text{ }^\circ\text{C}$, $V_{CC} = 17\text{ V}$

Parameter	Symbol	Conditions	Pins	Min.	Typ.	Max.	Unit
Start / Stop Operation							
Operation Start Voltage	$V_{CC(ON)}$		1 – 2	10.0	11.0	12.0	V
Operation Stop Voltage	$V_{CC(OFF)}$		1 – 2	7.4	8.3	9.2	V
Circuit Current in Operation	$I_{CC(ON)}$		1 – 2	—	0.52	1.1	mA
Circuit Current in Non-operation	$I_{CC(OFF)}$	$V_{CC} = 9\text{ V}$	1 – 2	—	0.25	0.60	mA
Input Side							
High Level Input Threshold Voltage	$V_{IN(H)}$		3 – 2	2.0	2.4	2.8	V
Low Level Input Threshold Voltage	$V_{IN(L)}$		3 – 2	0.6	1.0	1.4	V
IN Pin Bias Current	$I_{IN(B)}$	$V_{IN} = 3.3\text{ V}$	3 – 2	—	32	75	μA
High-side Driver							
High-side Driver Operation Start Voltage	$V_{BUV(ON)}$		5 – 6	5.8	6.8	7.8	V
High-side Driver Operation Stop Voltage	$V_{BUV(OFF)}$		5 – 6	5.4	6.4	7.4	V
Output Side							
Turn-on Propagation Delay	t_{dLH}	See Figure 2-1	3 – 2 7 – 6	—	—	300	ns
Turn-off Propagation Delay	t_{dHL}	See Figure 2-1	3 – 2 7 – 6	—	—	300	ns
VGO Pin Source Current (Peak)	$I_{GO(SRC)}$	$V_B = 17\text{ V}$, $V_{GO} = 0\text{ V}$	7 – 6	—	-300	—	mA
VGO Pin Sink Current (Peak)	$I_{GO(SNK)}$	$V_B = 17\text{ V}$, $V_{GO} = 17\text{ V}$	7 – 6	—	550	—	mA
Protection							
VCC Pin OVP Threshold Voltage	$V_{CC(OVP)}$		1 – 2	18.1	19.0	19.7	V
TSD Operating Temperature	$T_{J(TSD)}$		—	125	157	—	$^\circ\text{C}$
Thermal Characteristic							
Junction-to-Air Thermal Resistance	θ_{J-A}		—	—	—	180	$^\circ\text{C/W}$

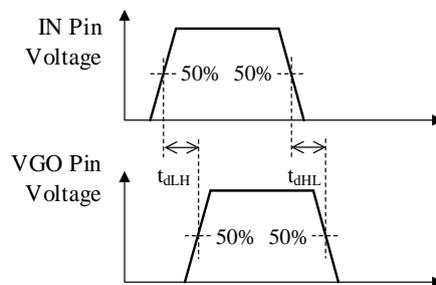
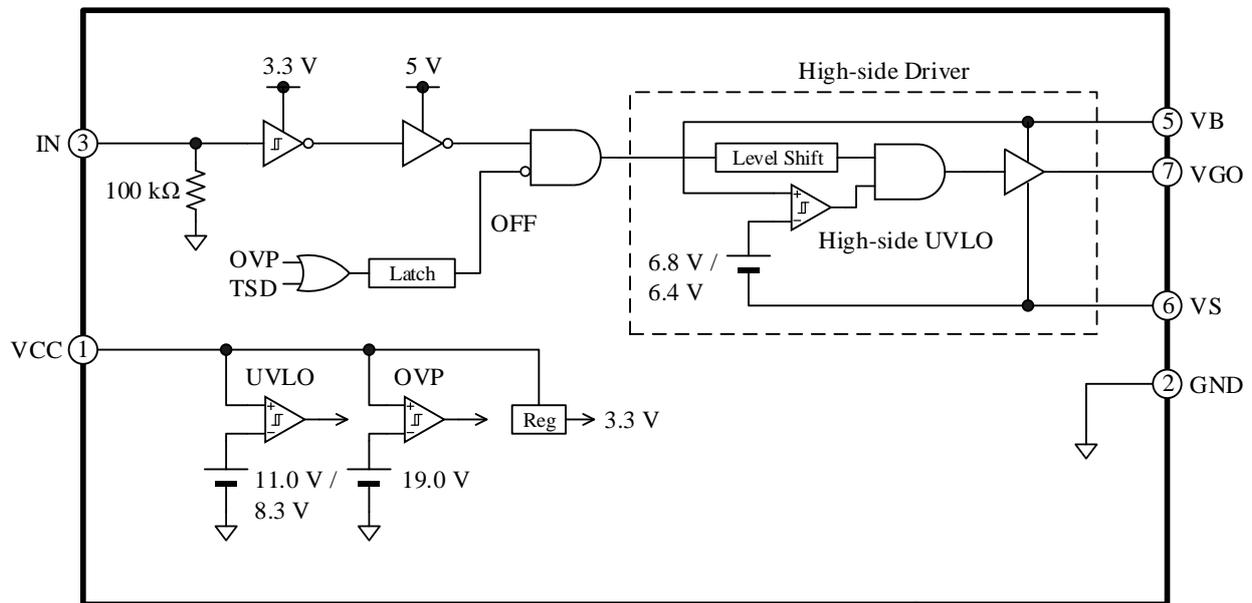
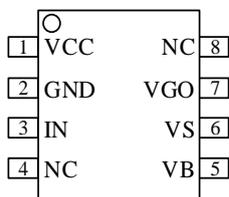

Figure 2-1. Input and Output Waveforms

3. Block Diagram



4. Pin Configuration Definitions



Pin Number	Pin Name	Description
1	VCC	Logic power supply input with VCC pin OVP
2	GND	Ground
3	IN	Signal input
4	NC	No connection
5	VB	Power supply input for high-side gate drive with UVLO
6	VS	Floating ground of high-side driver
7	VGO	High-side gate drive output
8	NC	No connection

5. Typical Application

Figure 5-1 shows the half-bridge converter example using the SSC4S790.

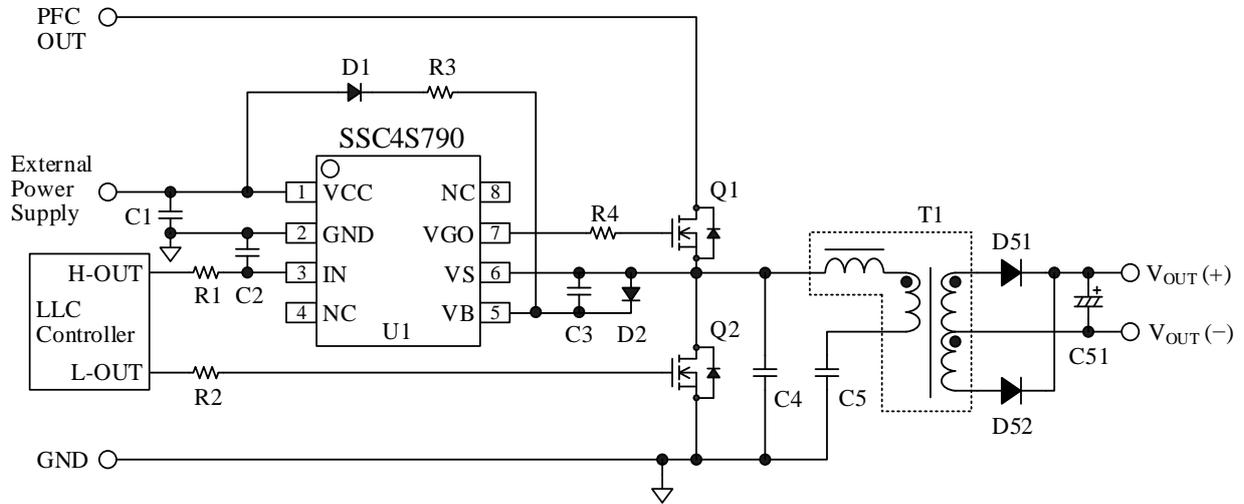
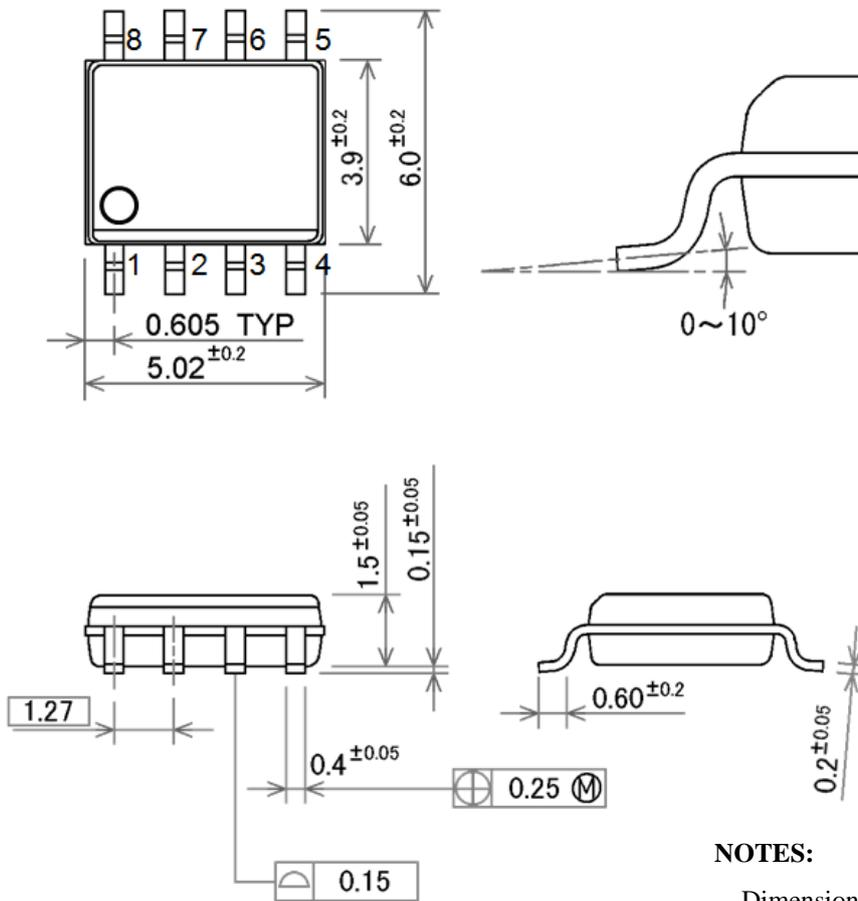

Figure 5-1. Half-bridge Converter Example Using SSC4S790

6. Physical Dimensions

• SOIC8 Package



NOTES:

- Dimensions in millimeters
- Pb-free

• SOIC8 Land Pattern Example

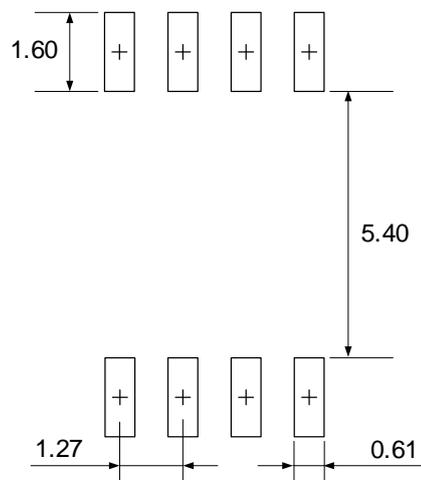

Unit: mm

7. Marking Diagram

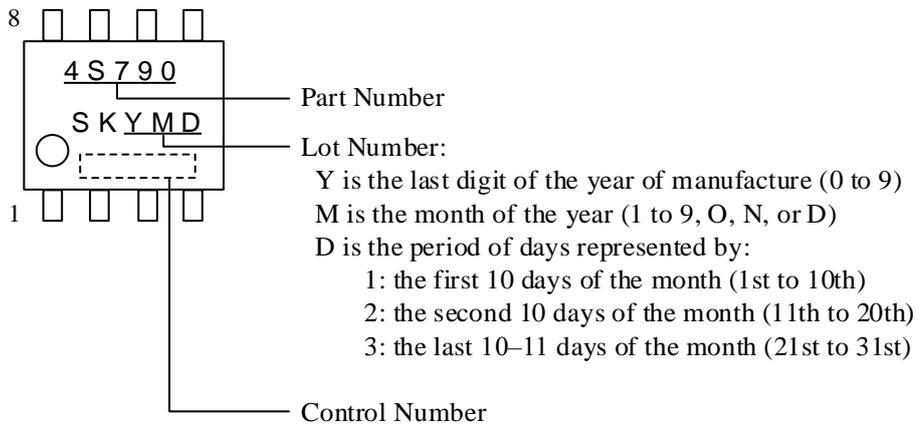

8. Operational Description

All of the parameter values used in these descriptions are typical values, unless they are specified as minimum or maximum. Current polarities are defined as follows: current going into the IC (sinking) is positive current (+); and current coming out of the IC (sourcing) is negative current (-).

8.1. Start / Stop Operation

Figure 8-1 shows the VCC pin peripheral circuit, Figure 8-2 shows the operational waveforms.

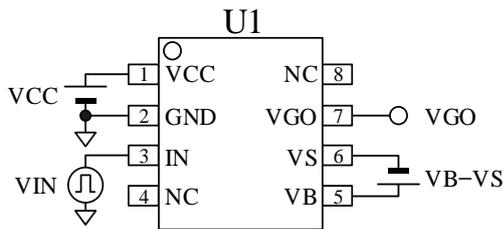

Figure 8-1. VCC Pin Peripheral Circuit

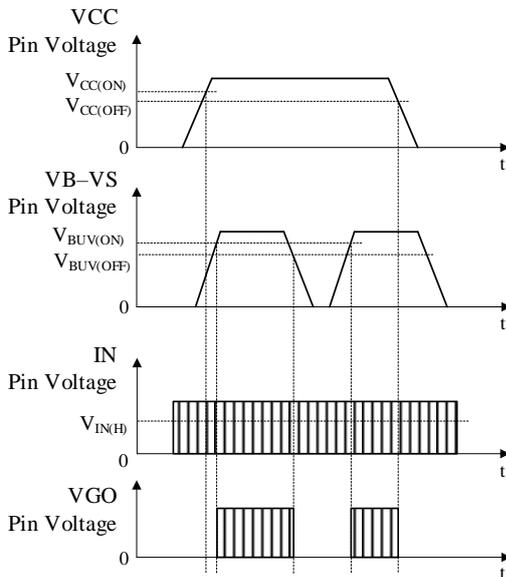

Figure 8-2. Operational Waveforms

This is the power supply pin for the built-in control circuit, and is connected to an external power supply. When the VCC pin voltage increases to $V_{CC(ON)} = 11.0$ V, the control circuit starts operating. When the VCC pin voltage decreases to $V_{CC(OFF)} = 8.3$ V or less, the control circuit stops operating by the VCC_UVLO (VCC Pin Undervoltage Lockout) (see Figure 8-3).

When the IC satisfies following conditions, the IC starts the switching operation according to the IN pin input signal (see Section 8.2.1):

- VCC pin voltage $\geq V_{CC(ON)} = 11.0$ V
- Voltage between VB and VS pins $\geq V_{BUV(ON)} = 6.8$ V

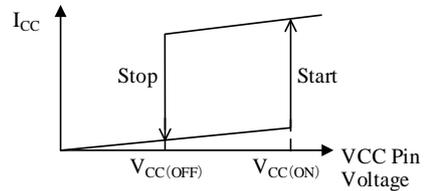

Figure 8-3. VCC vs. ICC

8.2. Pin Descriptions

8.2.1. IN

This is the signal input pin compatible with 3.3 V logic signal.

When the IN pin voltage increases to $V_{IN(H)} = 2.4$ V or more, the VGO pin outputs “H”. When the IN pin voltage decreases to $V_{IN(L)} = 1.0$ V or less, the VGO pin outputs “L”.

The IN pin is connected to the 100 kΩ pull-down resistor internally (see Section 3).

8.2.2. VB and VS

The VB pin is the input of the high-side floating power supply, whereas the VS pin is the ground of the high-side floating power supply. The SSC4S790 incorporates the high-side driver undervoltage lockout (V_{B_UVLO}) between the VB and VS pins (see Section 8.3).

Figure 8-4 is a schematic diagram of the bootstrap circuit that drives the high-side power MOSFET (Q1).

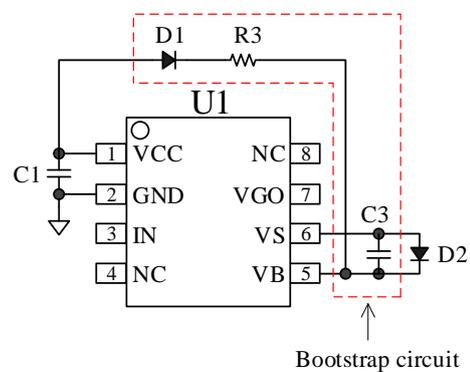

Figure 8-4. Bootstrap Circuit

In the condition where the high-side power MOSFET is turned off and the low-side power MOSFET (Q2) is turned on, the VS pin voltage has almost the same potential as the ground. Then, C3 is charged with the VCC pin. When the voltage between the VB and VS pins (hereafter “VB–VS voltage”) increases to $V_{\text{BUV(ON)}} = 6.8 \text{ V}$ or more, the internal high-side driver starts operating. When VB–VS voltage decreases to $V_{\text{BUV(OFF)}} = 6.4 \text{ V}$ or less, the internal high-side driver stops operating (i.e., VB_UVLO). The VB_UVLO protects the IC in case both ends of C3 and D2 are shorted. The bootstrap circuit components must meet the following:

- **D1**
D1 should be a fast recovery diode with a short recovery time and a low reverse current. When the maximum supply input voltage is specified at 265 VAC, it is recommended to use a fast recovery diode with $V_{\text{RM}} = 600 \text{ V}$.
- **C1, C3, R3**
The values of C1, C3, and R3 are determined by the following parameters: the total amount of gate charges of the external power MOSFETs, Qg; the amount of a voltage dip between the VB and VS pins during operation at the lowest oscillation frequency. C1, C3, and R3 should be adjusted according to voltages measured by a high-voltage differential probe so that VB–VS voltage exceeds $V_{\text{BUV(ON)}} = 6.8 \text{ V}$. C1 and C3 should be film or ceramic capacitors with a low ESR and a low leakage current. The reference value of C1 is $0.47 \mu\text{F}$ to $1 \mu\text{F}$. C3 should have a capacitance of $0.047 \mu\text{F}$ or more. R3 should have a resistance of 1Ω to 10Ω .
- **D2**
D2 is used for protecting the VS pin from having a negative potential. D2 should be a Schottky diode with a low forward voltage so that VB–VS voltage does not fall below -0.3 V of its absolute maximum rating.

8.2.3. VGO

The VGO pin is gate drive output for the external power MOSFET. This peak source and sink currents are -300 mA and 550 mA , respectively.

To increase a falling speed of the gate at power MOSFET turn-off, connect the diode D_S as shown in Figure 8-5. R_A and D_S should be adjusted based on the operation performance checked with an actual board, including a loss in the power MOSFET, gate waveform (e.g., ringing due to pattern layout), and EMI noise. To prevent malfunction caused by steep dv/dt at power MOSFET turn-off, connect R_{GS} , of about $10 \text{ k}\Omega$ to $100 \text{ k}\Omega$, between the gate and source of the power

MOSFET with a minimal length of traces.

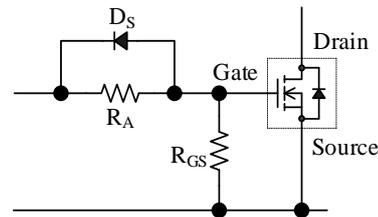

Figure 8-5. Power MOSFET Peripheral Circuit

8.3. High-side Driver Undervoltage Lockout

The SSC4S790 incorporates the high-side driver undervoltage lockout (VB_UVLO) between the VB and VS pins.

When the voltage between the VB and VS pins (i.e., “VB–VS voltage”) increases to $V_{\text{BUV(ON)}} = 6.8 \text{ V}$ or more, the internal high-side driver starts operating. When the VB–VS voltage decreases to $V_{\text{BUV(OFF)}} = 6.4 \text{ V}$ or less, the internal high-side driver stops operating. The VB_UVLO protects the IC in case both ends of the capacitor C3 for bootstrap circuit and the protective diode D2 are shorted.

8.4. VCC Pin Overvoltage Protection (OVP)

When the voltage between the VCC and GND pins increases to $V_{\text{CC(OVP)}} = 19.0 \text{ V}$ or more, the VCC pin overvoltage protection (VCC_OVP) is activated. Then, the IC stops switching operation at the latched state. To release the latched state, decrease the VCC pin voltage to $V_{\text{CC(OFF)}} = 8.3 \text{ V}$ or less.

The VCC pin input voltage must be set less than the its absolute maximum rating of 20 V .

8.5. Thermal Shutdown (TSD)

When the control circuit temperature reaches $T_{\text{J(TSD)}} = 157 \text{ }^\circ\text{C}$, the thermal shutdown (TSD) is activated. Then, the IC stops switching operation at the latched state. To release the latched state, decrease the VCC pin voltage to $V_{\text{CC(OFF)}} = 8.3 \text{ V}$ or less.

Important Notes

- All data, illustrations, graphs, tables and any other information included in this document (the “Information”) as to Sanken’s products listed herein (the “Sanken Products”) are current as of the date this document is issued. The Information is subject to any change without notice due to improvement of the Sanken Products, etc. Please make sure to confirm with a Sanken sales representative that the contents set forth in this document reflect the latest revisions before use.
- The Sanken Products are intended for use as components of general purpose electronic equipment or apparatus (such as home appliances, office equipment, telecommunication equipment, measuring equipment, etc.). Prior to use of the Sanken Products, please put your signature, or affix your name and seal, on the specification documents of the Sanken Products and return them to Sanken. When considering use of the Sanken Products for any applications that require higher reliability (such as transportation equipment and its control systems, traffic signal control systems or equipment, disaster/crime alarm systems, various safety devices, etc.), you must contact a Sanken sales representative to discuss the suitability of such use and put your signature, or affix your name and seal, on the specification documents of the Sanken Products and return them to Sanken, prior to the use of the Sanken Products. The Sanken Products are not intended for use in any applications that require extremely high reliability such as: aerospace equipment; nuclear power control systems; and medical equipment or systems, whose failure or malfunction may result in death or serious injury to people, i.e., medical devices in Class III or a higher class as defined by relevant laws of Japan (collectively, the “Specific Applications”). Sanken assumes no liability or responsibility whatsoever for any and all damages and losses that may be suffered by you, users or any third party, resulting from the use of the Sanken Products in the Specific Applications or in manner not in compliance with the instructions set forth herein.
- In the event of using the Sanken Products by either (i) combining other products or materials or both therewith or (ii) physically, chemically or otherwise processing or treating or both the same, you must duly consider all possible risks that may result from all such uses in advance and proceed therewith at your own responsibility.
- Although Sanken is making efforts to enhance the quality and reliability of its products, it is impossible to completely avoid the occurrence of any failure or defect or both in semiconductor products at a certain rate. You must take, at your own responsibility, preventative measures including using a sufficient safety design and confirming safety of any equipment or systems in/for which the Sanken Products are used, upon due consideration of a failure occurrence rate and derating, etc., in order not to cause any human injury or death, fire accident or social harm which may result from any failure or malfunction of the Sanken Products. Please refer to the relevant specification documents and Sanken’s official website in relation to derating.
- No anti-radioactive ray design has been adopted for the Sanken Products.
- The circuit constant, operation examples, circuit examples, pattern layout examples, design examples, recommended examples, all information and evaluation results based thereon, etc., described in this document are presented for the sole purpose of reference of use of the Sanken Products.
- Sanken assumes no responsibility whatsoever for any and all damages and losses that may be suffered by you, users or any third party, or any possible infringement of any and all property rights including intellectual property rights and any other rights of you, users or any third party, resulting from the Information.
- No information in this document can be transcribed or copied or both without Sanken’s prior written consent.
- Regarding the Information, no license, express, implied or otherwise, is granted hereby under any intellectual property rights and any other rights of Sanken.
- Unless otherwise agreed in writing between Sanken and you, Sanken makes no warranty of any kind, whether express or implied, including, without limitation, any warranty (i) as to the quality or performance of the Sanken Products (such as implied warranty of merchantability, and implied warranty of fitness for a particular purpose or special environment), (ii) that any Sanken Product is delivered free of claims of third parties by way of infringement or the like, (iii) that may arise from course of performance, course of dealing or usage of trade, and (iv) as to the Information (including its accuracy, usefulness, and reliability).
- In the event of using the Sanken Products, you must use the same after carefully examining all applicable environmental laws and regulations that regulate the inclusion or use or both of any particular controlled substances, including, but not limited to, the EU RoHS Directive, so as to be in strict compliance with such applicable laws and regulations.
- You must not use the Sanken Products or the Information for the purpose of any military applications or use, including but not limited to the development of weapons of mass destruction. In the event of exporting the Sanken Products or the Information, or providing them for non-residents, you must comply with all applicable export control laws and regulations in each country including the U.S. Export Administration Regulations (EAR) and the Foreign Exchange and Foreign Trade Act of Japan, and follow the procedures required by such applicable laws and regulations.
- Sanken assumes no responsibility for any troubles, which may occur during the transportation of the Sanken Products including the falling thereof, out of Sanken’s distribution network.
- Although Sanken has prepared this document with its due care to pursue the accuracy thereof, Sanken does not warrant that it is error free and Sanken assumes no liability whatsoever for any and all damages and losses which may be suffered by you resulting from any possible errors or omissions in connection with the Information.
- Please refer to our official website in relation to general instructions and directions for using the Sanken Products, and refer to the relevant specification documents in relation to particular precautions when using the Sanken Products.
- All rights and title in and to any specific trademark or tradename belong to Sanken and such original right holder(s).

DSGN-CEZ-16003